

(19) World Intellectual Property Organization
International Bureau



(43) International Publication Date
21 December 2007 (21.12.2007)

PCT

(10) International Publication Number
WO 2007/144564 A2

(51) International Patent Classification:
E04B 1/344 (2006.01)

(21) International Application Number:
PCT/GB2007/001937

(22) International Filing Date: 24 May 2007 (24.05.2007)

(25) Filing Language: English

(26) Publication Language: English

(30) Priority Data:
0611626.3 13 June 2006 (13.06.2006) GB

(71) Applicant (for all designated States except US): **RAPID DEPLOYMENT SYSTEMS UK LIMITED** [GB/GB]; Brookside Farm, Woodhatch Road, Salfords, Redhill, Surrey RH1 5JJ (GB).

(72) Inventors; and

(75) Inventors/Applicants (for US only): **WOOD, Martin, Nicholas** [GB/GB]; 1 Torrington Road, Berkhamsted, Herts HP4 3WD (GB). **NOSEK, Filip, Jan** [DE/GB]; Northwood Hall 4-16, Hornsey Lane, London N6 5PJ (GB).

(74) Agent: **MARCH, Gary, Clifford**; HLBBshaw, 10th Floor, 1 Hagley Rd, Birmingham B16 8TG (GB).

(81) Designated States (unless otherwise indicated, for every kind of national protection available): AE, AG, AL, AM, AT, AU, AZ, BA, BB, BG, BH, BR, BW, BY, BZ, CA, CH, CN, CO, CR, CU, CZ, DE, DK, DM, DZ, EC, EE, EG, ES, FI, GB, GD, GE, GH, GM, GT, HN, HR, HU, ID, IL, IN, IS, JP, KE, KG, KM, KN, KP, KR, KZ, LA, LC, LK, LR, LS, LT, LU, LY, MA, MD, MG, MK, MN, MW, MX, MY, MZ, NA, NG, NI, NO, NZ, OM, PG, PH, PL, PT, RO, RS, RU, SC, SD, SE, SG, SK, SL, SM, SV, SY, TJ, TM, TN, TR, TT, TZ, UA, UG, US, UZ, VC, VN, ZA, ZM, ZW.

(84) Designated States (unless otherwise indicated, for every kind of regional protection available): ARIPO (BW, GH, GM, KE, LS, MW, MZ, NA, SD, SL, SZ, TZ, UG, ZM, ZW), Eurasian (AM, AZ, BY, KG, KZ, MD, RU, TJ, TM), European (AT, BE, BG, CH, CY, CZ, DE, DK, EE, ES, FI, FR, GB, GR, HU, IE, IS, IT, LT, LU, LV, MC, MT, NL, PL, PT, RO, SE, SI, SK, TR), OAPI (BF, BJ, CF, CG, CI, CM, GA, GN, GQ, GW, ML, MR, NE, SN, TD, TG).

Published:

— without international search report and to be republished upon receipt of that report

For two-letter codes and other abbreviations, refer to the "Guidance Notes on Codes and Abbreviations" appearing at the beginning of each regular issue of the PCT Gazette.

(54) Title: PORTABLE BUILDINGS

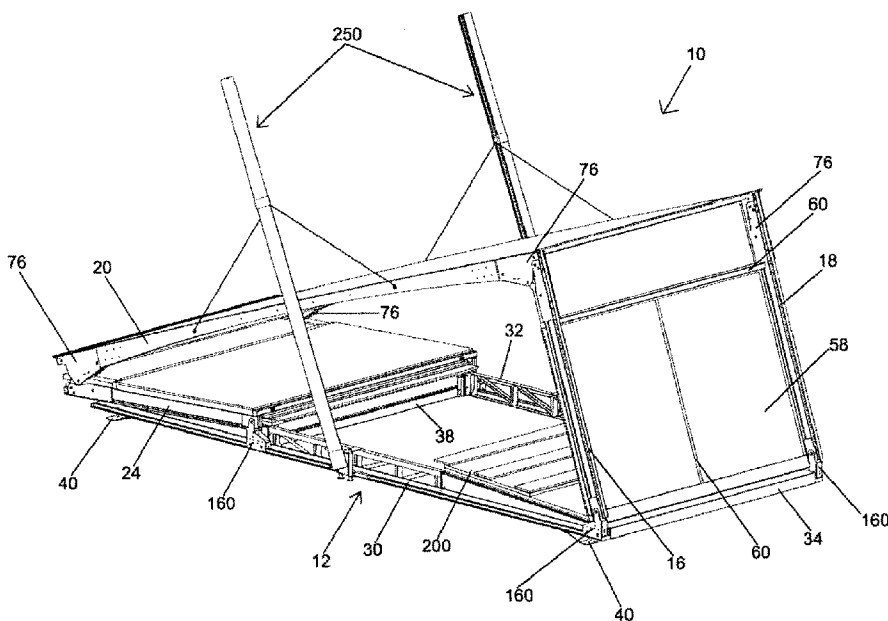

(57) Abstract: A portable building unit (10) includes a base (12), a roof (44) and opposed end walls (58) pivot connected between the base and the roof. The end walls (58) are slideable with respect to one of the base and the roof such that, in use, movement of the roof away from the base causes the end walls to be raised from a collapsed storage condition to an upright use condition.

WO 2007/144564 A2

PORTABLE BUILDINGS

5 **Field of the Invention**

The invention relates to portable buildings and in particular to portable buildings and frames for portable buildings that can be collapsed for transport or storage purposes.

Background to the Invention

- 0 Portable building units are known for many uses, such as temporary office space for building sites. Typically, portable building units are transported between sites in a ready to use condition such that they can simply be hoisted from the transport vehicle into position and brought into use by simply connecting up services, such as water and electricity. This can be inconvenient, since for road transportation it is usually possible to transport just one portable
- 5 building unit per vehicle. Also, when not in use, such portable building units can require a considerable amount of storage space.

Summary of the Invention

- The invention provides a frame for a portable building unit, said frame comprising a floor
- 0 frame portion, a roof frame portion, a first connecting frame portion connecting the roof frame portion with the floor frame portion and a second connecting frame portion connecting the roof frame portion with the floor frame portion, each said connecting frame portion being hinge connected to one of said floor frame portion and said roof frame portion and slide
- 5 connected to the other of said floor frame portion and said roof frame portion, the arrangement being such that in use, the frame can be erected from a collapsed condition in which the roof frame portion and first and second connecting frame portions are disposed adjacent said floor frame portion to a use condition in which the roof frame portion is spaced
- 0 apart from the floor frame portion and supported by said first and second frame connecting portions by applying a lifting force to said roof frame portion which causes relative pivoting movement of said roof frame portion and the first and second frame connecting portions and sliding and pivoting movement of the first and second connecting frame portions relative to the floor frame portion.

- The invention also includes a portable building unit comprising a base, a roof and opposed
- 5 end walls pivot connected between said base and said roof and slideable with respect to one of the base and the roof such that, in use, movement of the roof away from the base causes the end walls to be raised from a collapsed condition to an upright use condition.

The invention a method of erecting a portable building unit from a collapsed storage condition, said portable building unit comprising a base, roofing, at least one first connecting member connecting between a first end region of the roofing and the base and at least one second connecting member connecting between a second end region of the roofing and the base and the method comprising applying a first force that causes said first end region of the roofing to lift with respect to the base and said at least one first connecting member to move from a collapsed condition to a finish position with respect to said roofing and thereafter applying a second force that causes said second end region of the roofing to lift with respect to the base and said at least one second connecting member to move from a collapsed storage condition to a finish position with respect to said roofing.

Brief Description of the Drawings

In order that the invention may be well understood, some embodiments thereof, which are given by way of example only, will now be described with reference to the drawings in which:

Figure 1 is perspective view showing a first embodiment of a collapsible portable building unit in a collapsed condition prior to erection;

Figure 2 is a view corresponding to Figure 1 showing the portable building unit on completion of the first stage of the erection process and with erecting devices fitted to its sides;

Figure 3 is a view corresponding to Figure 2 showing the portable building unit on completion of a second stage of the erection process;

Figure 4 is a view corresponding to Figure 3 showing the portable building unit on completion of a third stage of the erection process;

Figure 5 is a side view of a hinge of the portable building unit in a state corresponding to the collapsed condition of the portable building unit shown in Figure 1:

Figure 6 is a side view of the hinge of Figure 5 in a state corresponding to the condition of the portable building unit shown in Figure 4;

Figure 7 is a view corresponding to that of Figure 6 showing a sealing arrangement of the portable building unit;

Figure 8 is a perspective view of a roller device for slide connecting end walls of the portable building unit with its floor frame portion:

Figure 9 is a perspective view of a corner of the portable building unit that is circled in Figure 10 showing a roller device of Figure 8 and a floor portion of the portable building unit in a raised condition;

Figure 10 is a view corresponding generally to the view shown in Figure 4, but showing the floor of the portable building unit in the process of being unfolded ready for use;

Figure 11 is a schematic illustration of a lifting system for the portable building unit;

Figure 12 shows a portion of an erection mast incorporating the system of Figure 11;

Figure 13 is a perspective view of a second embodiment of a collapsible portable building unit; and

Figure 14 is a second view of the portable building unit of Figure 13 showing a later stage of construction.

Detailed Description of the Preferred Embodiment

Figures 1 to 4 illustrate the erection of a collapsible portable building unit 10 from a collapsed storage condition (Figure 1) to a fully erected, use, condition (Figure 4). The portable building unit 10 comprises a frame comprising a floor frame portion 12, a pair of first connecting frame portions 16,18 that connect a first end of the floor frame with a first end of a roof frame portion that comprises opposed side members 20 (only one of which can be seen in the drawings) and a pair of second connecting frame portions 24,26 that connect a second end of the floor frame portion with the second end of the roof frame portion. As described in more detail below, the first and second connecting frame portions 16,18,24,26 are hinge connected to the side members 20 of the roof frame portion and slide connected to the floor frame portion 12.

The arrangement of the frame is such that it can be erected from the collapsed storage condition shown Figure 1 to the use condition shown in Figure 4 by applying sliding and lifting forces to the side members 20 of the roof frame portion. The lifting of the side

members 20 causes relative pivoting movement of the side members and the first and second connecting frame portions 16,18,24,26 and sliding and pivoting movement of the first and second connecting frame portions relative to the floor frame portion 12. As can be seen from Figures 1 to 4, the relative movement allowed by the connections between the connecting frame portions 16,18,24,26 and the floor frame portion 12 and side members 20 of the roof frame portion allows the frame to be unfolded from a generally flat packed condition to its use condition by moving the side members 20 and floor frame portion 12 away from one another.

The floor frame portion 12 includes elongate side members 30,32 disposed in parallel spaced apart relation and interconnected by transverse end members 34, only one of which is visible in the drawings. An additional connection between the side members 30,32 is provided by a pair of transverse frame portions 38, of which only one is visible in the drawings.

Feet 40 are provided at the four corners of the floor frame portion 12 and are preferably provided with a jacking arrangement by means of which the floor frame portion can be levelled. In the embodiment, the feet 40 comprise metal strips that curve in their lengthways direction. The feet 40 are cantilevered from the side members 30,32 to which they are connected by means of respective pivot pins. The jacking arrangement comprises respective bolts 42, which pass through threaded holes provided in the side members 30,32 and engage the feet 40. Levelling of the floor frame portion 12 is achieved by rotating the bolts 42, which according to the direction of rotation, causes the floor frame portion 12 to be lifted or allowed descend.

The opposed side members 20 of the roof frame portion are connected by a roof panel member 44. The roof panel member 44 may be a single panel as shown or comprise a plurality of joined panel members. Although not shown, the roof panel member 44 may be provided with stiffening members, which may extend in the lengthways and/or widthways direction of the portable building unit.

The pair of first connecting frame portions 16,18 comprises respective side beams that are disposed in opposed parallel spaced apart relation and interconnected by panelling to form a first end wall 58 of the portable building unit 10. The panelling of the first end wall 58 may be provided in any convenient manner including a single panel or, as shown, a plurality of panels. The panelling of the first end wall 58 may be provided with stiffening members 60 as shown. The pair of second connecting frame portions 24,26 similarly comprises respective

side beams that are disposed in opposed parallel spaced apart relation and interconnected by panelling to form a second end wall 62 (Figure 4) of the portable building unit 10.

The first and second end walls 58,62 are pivot connected to the side members 20 of the roof frame portion by respective pairs of hinges 76. As best seen in Figures 5 and 6, the hinges 76 comprise a twin lever arrangement comprising a first lever arm 78 and a second lever arm 80. The first lever arm 78 is connected to a first mounting part 82 of the hinge 76 by a pivot pin 84. Similarly the second lever arm 80 is connected to the first mounting part 82 by a pivot pin 86. The lever arms 78,80 are able to pivot about their respective pivot pins 84,86. The first mounting part 82 of each hinge is fixed to a respective end of one of the side members 20 of the roof frame portion. The first lever arm 78 is additionally connected to a second mounting part 88 of the hinge 76 by a pivot pin 90 and the second lever arm 80 is connected to the second mounting part by a pivot pin 92. The lever arms 78,80 are able to pivot about their respective pivot pins 90,92. The second mounting part 92 of each hinge 76 is fixed to a respective one of the first and second connecting frame portions 16,18,24, 26. Thus, the hinges 76 form the connection between the roof 20,44 of the portable building unit 10 and the end walls 58,62 and permit pivoting movement of the end walls and roof with respect to one another.

In the drawings, the hinges 76 are shown as comprising just one first lever arm 78 and one second lever arm 80. It will be appreciated that this is not essential. Each hinge 76 may comprise a plurality of first lever arms 78 mounted side by side or in parallel spaced arrangement on the same pins 84,90. Similarly, there may be a plurality of second lever arms 80. The number of lever arms used may be selected to provide the hinge 76 with a desired load bearing capability. In a presently preferred embodiment, there are four first lever arms 78 and four second lever arms 80. In each case, the four arms are disposed in parallel spaced apart relation.

The hinges 76 are provided with an integral locking system for locking the roof and end walls 58 to one another when in their use position. Referring to Figures 6 and 7, the locking system comprises a first lock portion in the form of a pin 110 carried by the first mounting part 82 of the hinge and a second lock portion in the form of a recess 112 and pivoting hook member 114 carried by the second mounting part 88 of the hinge. The locking system additionally comprises a locking screw adjuster 116 that is used to move the hook 114 between a position in which it allows the pin 110 to enter the recess 112 and a position in which it prevents the pin from leaving the recess. The adjuster 116 comprises a rod 118 that is pivotably connected at one end to the hook 114 and has a threaded sleeve at its other

end. The sleeve is located in a U-shaped bracket 120 that is fixed to the second mounting part 88 of the hinge 76. A screw 122 passes through an aperture provided in the U-shaped bracket 120 and engages in the sleeve. By rotating the screw the hook can be moved back and forth to control entry to the recess 112.

Although only one hook 114 is shown in the drawings, it is preferred to provide four hooks in parallel. For this arrangement, there is a second hook on the opposite side of the hinge that corresponds to the illustrated hook, two further hooks mounted at positions between those hooks and the pin 110 is made sufficiently long to allow it to extend from either end of the recess 112. The two outer hooks are positioned to engage the respective ends of the pin that project from the recess. It will be understood that by providing a suitable linkage, the four hooks can be driven together by a single adjuster 116.

Side plates cover the hinges 76. In order to improve the clarity of the drawings, these have been removed from the views shown in Figures 6 and 7. The side plates are provided on the inner and outer sides of the hinge and provide protection to the moving parts of the hinge. The outer side plates can be seen in Figures 1 to 4.

As shown in Figure 7, the upper edges of the end walls 58 are provided with a weather seal in the form of a tubular sealing member 130, which extends along the upper edge of the wall and is secured thereto by any convenient means. The sealing member 130 may be made of any suitable material such as an elastomer and does not have to be tubular. The roof panel member 44 is provided with a recess 132 extending across its full width to receive the sealing member 130. When the roof panel member 44 and end walls 58 are in their use positions, the sealing members 130 are received in the respective recess 132, which are configured such that the sealing members are compressed to form a substantially airtight seal between the roof panel member and the end walls. It can be seen from Figure 7 that the ends of the roof panel member 44 and the recess 132 are each configured to provide a lead in, which allows the sealing member 130 to move into the recess as the roof and end walls move into their use positions.

The first and second walls 58,62 are slide connected to the floor frame portion 12 by roller devices 160. As shown in Figure 4, there is a roller device 160 connected to the lower end of each of the first and second frame connecting portions 16,18,24,26.

The rolling devices 160 each comprise a pair of generally trapezoidal side plates 162,164 each of which has an upwardly projecting horn 166 at one corner. The side plates 162,164

are disposed in parallel spaced apart relation and secured to one another via transverse plates 170,172,174,176. A pivot pin 178 extends between the horns 166 and is secured to them by means of a pair of circlips 180, only one of which can be seen in the drawing. A centrally disposed guide plate 182 is disposed parallel to the side plates 162,164 and supported by the transverse plates 170,172,174. A pair of roller pins 184 extends between the side plates 162, 164 and is secured to them by means of circlips 186. The roller pins 184 are disposed in parallel spaced apart relation and each supports a roller 188, only one of which can be seen in the drawing. The rollers 188 are able to rotate relative to the roller pins 184.

Referring to Figure 9, the roller devices 160 are arranged to slide along the side members 30,32 of the floor frame portion 12 and are pivot connected to respective first and second connecting frame portions 16,18,24,26, thus allowing for relative pivoting movement between the end walls 58,62 and the floor frame portion 12. Each side member 30,32 includes a flat surface along which the rollers 188 can roll and a pair of upstanding rails 190 that run in parallel along the side members. The upstanding rails 190 sandwich the guide plates 182 such that the rolling devices 160 are constrained to run in a substantially straight line along the side members. As can be seen from a comparison of Figures 1 and 2 with Figures 3 and 4, the roller devices 160 allow the end walls 58,62 to pivot through an angle somewhat greater than 90° while the ends of the end walls to which the rolling devices are attached slide a distance approximating to the height of the end walls. This combined with the pivoting movement permitted by the hinges, allows the end walls to pivot and slide from a position in which they are sandwiched between and lie generally parallel to the floor frame portion 12 and roof 20,44 to an upright use condition..

Referring to Figures 9 and 10, the floor frame portion 12 supports floor panels 200,202,204,206. A respective floor panel 200, 202 extends from the ends of the floor frame portion 12 towards the centre of the portable building unit 10. The floor panel 204 is hinge connected to the more centrally disposed end of the floor panel 200. Similarly, the floor panel 206 is hinge connected to the more centrally disposed end of the floor panel 202. As best seen in Figures 3 and 4, the hinge connections allow the floor panels 204,206 to be folded back to a position in which they lie on the respective floor panel 200,202 to which they are connected. From that folded back condition, the floor panels 204,206 can be pivoted through a little more than 180° to bring them to a position in which they are substantially horizontally disposed and their free ends meet to provide a substantially continuous floor surface.

The floor panels 200,202 are arranged to pivot about their more centrally disposed ends, between a storage position in which they are inclined with respect to the floor frame portion 12 and a use position in which they are generally horizontally disposed. The inclined position of the floor panels 200,202 can be best seen in Figure 4, while the horizontal position can be seen in Figures 9 and 10.

A jacking arrangement is provided for causing the floor panels to pivot between their inclined and horizontal positions. In this embodiment, the jacking arrangement comprises a plurality of jacks in the form of a bolt 210 (Figure 9) which extends through a nut 212 that is welded to the floor panel and through the floor panel into the blind bore (not shown) provided in the floor frame portion 12. The bolt 210 is a clearance fit in the blind bore. There is a nut/bolt/blind bore combination in the two corners of each floor panel 200,202 adjacent the ends of the floor frame portion 12. By rotating the bolts 210 in one direction, the floor panels 200,202 can be raised from their inclined positions to a horizontal position and by rotating in the opposite direction, they can be allowed to descend from their horizontal positions to their inclined storage positions.

The collapsible portable building unit 10 can be erected by many different mechanisms or devices capable of providing the necessary lifting force to the roof. For example, a crane might be used. Alternatively, the forks of a forklift truck might be run into the gap 240 (Figure 1) between the folded back floor panels, 200, 202, 204, 206 and used to raise the roof away from the floor frame portion 12. Yet another alternative and the presently preferred method is to use erection masts 250 (Figures 2 to 4). The lifting structure incorporated into the erection masts 250 is illustrated in Figure 11 and the upper portion of a mast is shown in Figure 12.

Referring to Figures 11 and 12, each erection mast 250 comprises a tubular member 252 fitted with a pulley 254 at its upper end. A sliding collar 256 is fitted on each tubular member 252. A cable 258 extends through the tubular member from a spool, or drum, 260 at the lower end of the tubular member and over the pulley 254 and is secured to a securing loop 262 that is fixed to the collar 256. Thus, by pulling on the cable 258, the collar can be caused to move up the erection mast and by allowing the cable to wind back, the collar can be caused to slide back down the erection mast.

The spool 260 is fitted with a worm wheel (not shown) that is engaged by a worm 264. The worm 264 can be driven by connecting it with an electric motor, or some other convenient electrical drive. Alternatively, a hand crank mechanism could be used to drive the worm 264.

In use, the lower ends of the erection masts 250 are secured to the elongate side members 30, 32 by means of respective releasable clamps 270 (Figure 10). The clamps 270 are located halfway along the side members 30, 32 and the erection masts 250 are pivotally connected to the clamps such that they can pivot about an axis extending perpendicular to the side members and across the width of the portable building unit. A respective cable 272 is passed through the securing loops 262 and has its ends secured to the adjacent side member 20 of the roof frame portion.

When the portable building unit 10 is in transit, the rolling devices 160 are pinned to prevent any sliding movement of the connecting frame portions 16,18,24,26 relative to the floor frame portion 12 thereby locking the portable building unit 10 in its collapsed condition. The pins (not shown) may pass through suitable apertures provided in the rolling devices 160 and engage in suitable apertures provided in the side members 30,32. Alternatively, the pins may simply engage in apertures located such that when the pins are inserted, they abut the ends of the rolling devices 160 that face the ends of the side members 30,32. The precise arrangement of the pins and apertures and any locking means provided to stop the pins working loose in transit are simple mechanical arrangements and since those skilled in the art will have no difficulty envisaging various suitable arrangements, they will not be described in greater detail.

Referring to Figures 1 and 2, the first stage of the erection process is commenced by removing the pins to free the rolling devices 160. The upper part of the portable building unit, which comprises the connecting frame portions 16,18,24,26, the side members 20 of the roof frame portion and the roof panel member 44, are pushed to the left (as viewed in Figures 1 and 2) so as to slightly overhang the left hand end of the floor frame portion 12. This completes the first stage of the erection process.

The sliding movement of the upper part of the portable building unit 10 that takes place during the first stage of the erection process may be accomplished by any convenient means. Provided the structure is sufficiently lightweight, the movement may be obtained by manually pushing the upper part. Alternatively, an arrangement of pulleys might be used, or the forks of a forklift truck might be used to provide a pushing force.

Prior to commencement of the second stage of the erection process, two of the pins are inserted in position to prevent the left hand end wall from lifting away from the floor frame portion 12 during the second stage and the erection masts 250 are clamped to the slide

members 30,32. Again, the pins may pass through apertures in the rolling devices, or simply into apertures positioned such that as the end wall begins to rise, its movement is blocked. Referring to Figures 2 and 3, it is the left hand end wall 58 that is pinned to prevent it lifting, although provided suitable apertures are provided, either end wall may be the pinned end wall.

With an end wall 58 suitably pinned, first stage of the erection process is commenced by rotating the worms 264 of the erection masts 250 by means of the chosen drive device (e.g. electric drive or hand crank). Although not shown, it will be appreciated that it is preferable for the worms 264 to be driven by a single drive device such that an equal force is applied simultaneously to the cables 258. The pulling force applied to the cables 258 pulls the collars 256 up the erection masts from the position shown in Figure 2 to the position shown in Figure 3. Since the left hand end wall 58 is pinned in position, the erection masts 250 pivot with respect to the base towards the left hand end wall so applying a lifting force to the side members 20 that pulls the right hand end of the roof upwards. That movement pulls on the right hand end wall 58, which gradually rises until the Figure 3 position is reached.

When the Figure 3 position is reached the hinges 76 have moved through their full range of movement and so the lifting process is stopped. At this stage the pins 110 of the hinge locking systems are engaged in the respective recesses 112. To stabilise the portable building unit, the right hand rolling devices 160 are then pinned to prevent them from returning towards the centre of the side members 30,32 and then the screws 122 of the right hand hinges 76 are rotated to move the respective hooks 114 across the recesses to hold the pins 110 in place and secure the joint formed between the right hand end wall 58 and the roof.

The third stage of the erection process is then commenced by removing the pins preventing the left hand end wall 58 from lifting and applying a lifting force to the cables 258. This causes the left hand end of the roof to rise and drag the left hand end wall 58 into its upright use position. As the left hand end wall 58 and left hand end of the roof rise, the right hand end wall 58 pivots about the pivot pins 178 of its rolling devices 160 and in the process moves from the position shown in Figure 3 to its upright use position shown in Figure 4. The erection process is then completed by securing the hinges 76 and rolling devices 160 attached to the left hand end wall in the same way as the left hand end wall. The erection masts 250 are then removed and side walls (not shown) can be fitted to complete the building. The side walls may be separate parts secured to the portable building unit by any

convenient means. Alternatively, as described below with reference to Figures 13 and 14, side walls may be provided as an integral part of the portable building unit.

It will be appreciated that it is not essential that the right hand end wall is the first end wall raised in the erection process. The portable building unit may be constructed for the first stage of the erection process to take place at the right end of the unit (as viewed in the drawings) or at either end according to choice. This is simply a matter of providing a suitable locking arrangement for preventing lifting the end wall at a selected end of the portable building unit, or both ends. It will also be appreciated that while it may be convenient to fit the erection masts at the end of the first stage of the erection process, they may be fitted first and may be equipped to assist in sliding the upper part of the portable building unit on the floor frame portion 12.

It will be appreciated that the folding construction of the portable building unit 10 allows the provision of the base (floor), roof and ends walls of a building unit in an integral structure that can readily be folded into a substantially flat position in which the end walls lie generally flat on the base and the roof lies generally flat on the end walls. From this flat packed storage condition, the portable building unit can be easily unfolded into its erect use condition. In order to complete the structure of the building, it is simply necessary to fit side walls to fill the spaces between the end walls and connect up any services such as electricity or water. It will also be appreciated that the side walls can be stacked on the roof when the portable building unit 10 is flat packed, thus presenting a relatively small volume for storage and transportation purposes. It is possible for the illustrated embodiment to provide a portable building unit with usable volume of 200m³ that can be transported on a single vehicle within 'normal' transport limits.

It will be appreciated that the twin lever configuration of the hinges connecting the roof and end walls allows for the provision of a stiff corner for forming a portal connection between the roof and end walls. At the same time, the hinge configuration provides a range of relative movement of the roof and end walls that permits the end walls and roof to fold such that the roof lies flat on the end walls, the gasket to move into sealing engagement with the underside of the roof and the locking pin to move into the recess to lock the hinge.

It will be appreciated that having a gasket arranged to automatically seal between the upper ends of the end walls and the underside of the roof as the end walls move into their use positions increases the speed and ease with which the portable building unit can be erected, so reducing the labour and cost involved.

It will be appreciated that in preferred embodiments, the collapsible portable building unit comprises a complete base, roof and at least end walls. However, the portable building unit could comprise frame portions to which panelling can be fitted to provide complete walls, flooring or roofing. Thus for example, instead of complete end walls, the portable building unit might comprise connecting, or supporting, members connecting between the roof and base to which panelling is fixed to form the end walls once the portable building unit has been erected. Similarly, the roofing may simply comprise roofing frame members to which roof panels are secured once the portable building unit has been erected. A more frame like structure would still provide the advantages of being compact for storage and transport with speed of erection of a frame to which panelling can be speedily affixed.

It will be appreciated that the structure of the portable building unit remains stable throughout the erection process, and in reverse, during collapse into the storage condition. This makes the portable building unit inherently safe to handle.

It will be appreciated that having sealing arrangements that are deployed automatically as the portable building unit is erected is advantageous in that it further simplifies the erection process thereby reducing labour costs and speeding up the erection process. It also avoids the possibility of steps being omitted during the construction process and, so the possibility of having to undo part of the process to allow the omitted steps to be carried out.

Referring now to Figures 13 and 14 a second embodiment of a collapsible portable building unit 300 has the same basic structure as the portable building unit 10 and so like reference numerals have been used to indicate common parts. In the drawings, the portable building unit 300 is shown in its erect condition and for ease of illustration, the end wall panelling and roof panel member 44 have been omitted.

The portable building unit 300 differs from the portable building unit 10 in that it has an integral side wall 302. The sidewall 302 is pivot connected along one edge to the side member 30. When the portable building unit 300 is in its collapsed condition, the side wall 302 lays down flat in the centrally disposed space 240 that is created by folding the floor panels 204, 206 back onto the floor panels 200, 202. The pivot connection to the side member 30 is configured such that the sidewall 302 can drop under the side member 20 as it nears its upright condition. When in its final upright position the sidewall 302 overlaps the side member 20.

As shown in Figure 14, the side wall 322 comprises five panels that are hinged one to another. Once the sidewall 302 is erect, the panels are unfolded so as to provide a complete cover for the side of the portable building unit 300. It will be appreciated that although not shown, the panels of the sidewall can be provided with window and/or door apertures. The inward facing sides of the side wall panel members may be provided with suitable seals for sealing against the side members 20,30 and connecting frame portions 16,24.

The side of the portable building unit 300 opposite the side closed by the side wall 302 may be completed with a separate side wall (not shown) as described in connection with the first embodiment. Alternatively, two portable building units 300 may be connected such that each provides a sidewall of the completed building. In this case, suitable seals would be provided between the two units 300 to make the building weatherproof.

It will be appreciated that by providing the portable building unit 300 with an integral side wall, further savings in transport and storage space are obtained. Furthermore, construction of a building is further simplified, since the side wall 302 can be simply pivoted and then unfolded to bring it into the correct position.

It will be appreciated that forming a building from two portable building units 300 provides the advantage of having all sides of the building ready connected and simply requiring erection and unfolding. It will be understood that since the portable building unit 300 is not 'handed', it is not necessary to provide different versions to form the two halves of a building.

It will be appreciated that when in their collapsed condition, two portable building units 320 can readily be transported on a single vehicle allowing a portable building with a usable volume of 400m³ to be transported on a single vehicle within 'normal' transport limits.

CLAIMS

1. A frame for a portable building unit, said frame comprising a floor frame portion, a roof frame portion, a first connecting frame portion connecting the roof frame portion with the floor frame portion and a second connecting frame portion connecting the roof frame portion with the floor frame portion, each said connecting frame portion being hinge connected to one of said floor frame portion and said roof frame portion and slide connected to the other of said floor frame portion and said roof frame portion, the arrangement being such that in use, the frame can be erected from a collapsed condition in which the roof frame portion and first and second connecting frame portions are disposed adjacent said floor frame portion to a use condition in which the roof frame portion is spaced apart from the floor frame portion and supported by said first and second frame connecting portions by applying a lifting force to said roof frame portion which causes relative pivoting movement of said roof frame portion and the first and second frame connecting portions and sliding and pivoting movement of the first and second connecting frame portions relative to the floor frame portion.
2. A frame for a portable building unit as claimed in Claim 1, wherein said first and second connecting frame portions are arranged to lock with the roof frame portion when in said use condition.
3. A frame for a portable building as claimed in Claim 2, wherein said roof frame portion is provided with respective first lock portions for releasably engaging respective second lock portions provided on said first and second connecting frame portions.
4. A frame for a portable building as claimed in Claim 3, wherein said first and second lock portions are arranged to engage as the roof frame portion and said first and second connecting frame portions move into said use condition.
5. A frame for a portable building as claimed in any one of the preceding claims, wherein said first and second connecting frame portions are connected to one of said floor frame portion and said roof frame portion by hinges that each comprise a plurality of arms, each arm being secured to the roof frame portion via a first pivot connection and to one of said first and second connecting frame portions by a second pivot connection.

6. A frame for a portable building as claimed in Claim 5 when dependent on Claim 3 or 4, wherein each said hinge comprises a first mounting part secured to said roof frame portion and a second mounting part secured to one of said first and second connecting frame portions and said first lock portions are provided on said first mounting part and said second lock portions are provided on said second mounting part.
7. A frame for a portable building as claimed in any one of the preceding claims, wherein said first and second connecting frame portions are connected to one of said floor frame portion and said roof frame portion by respective roller devices, which roller devices permit relative sliding movement of the connecting frame portions with respect to that one of the floor frame portion and roof frame portion.
8. A frame for a portable building unit as claimed in Claim 7, wherein each said roller device is pivot connected to the respective first and second connecting frame portion.
9. A frame for a portable building unit as claimed in Claim 7 or 8, wherein said floor frame portion comprises guide rails for said roller devices.
10. A frame for a portable building as claimed in any of one of the preceding claims, wherein each of said first and second connecting frame portions comprises two elongate connecting members, said elongate connecting members of the first connecting frame portion being disposed in parallel spaced apart relation, one at each side of the floor frame portion and said elongate connecting members of the second connecting frame portion being disposed in parallel spaced apart relation, one at each side of the floor frame portion.
11. A portable building unit comprising a base, a roof and opposed end walls pivot connected between said base and said roof and slideable with respect to one of the base and the roof such that, in use, movement of the roof away from the base causes the end walls to be raised from a collapsed condition to an upright use condition.
12. A portable building unit as claimed in Claim 11, wherein said end walls are connected to said base by respective pivot connections that are arranged for sliding movement along the base.

13. A portable building unit as claimed in Claim 12, wherein said base comprises elongate side members that define respective rails, said pivot connections including rolling members that roll along said rails to provide said relative sliding movement.
14. A portable building unit as claimed in Claim 13, wherein each said pivot connection comprises two hinges, the two hinges being secured to opposite sides of the respective end walls and each comprising at least one said rolling member.
15. A portable building unit as claimed in any one of Claims 11 to 14, wherein said base comprises a floor that includes respective movable floor members that are movable from a stored position to a use position in which the floor members substantially prevent sliding movement of said end walls from said upright use condition.
16. A portable building unit as claimed in Claim 15, wherein said floor members extend from the respective end walls and are pivotable about respective pivot axes that are disposed adjacent the ends of the floor members that are remote from the end walls.
17. A portable building unit as claimed in Claim 15 or 16, wherein said floor includes respective pivotable floor members that are connected with said movable floor members and are pivotable between a storage position in which they overlie the respective movable floor members and a use position in which they extend from the movable floor members to provide a substantially continuous floor surface.
18. A portable building unit as claimed in any one of Claims 11 to 17, further comprising a sidewall pivot connected to said base, the side wall being pivotable between a storage position in which it lies across the base and an upright use position.
19. A portable building unit as claimed in Claim 18, wherein said side wall comprises a first member pivot connected to said base and at least one second member pivot connected to said first member such that it can be pivoted from a position in which it faces said first member to a position in which it is disposed side by side with said first member to define a substantially continuous wall.
20. A portable building unit as claimed in Claim 19, comprising a third panel member pivot connected to a said second panel member such that it can be pivoted from a position in which it faces said second member to a position in which it is disposed side by side with said first member to define a substantially continuous wall.

21. A portable building unit as claimed in Claim 18, 19 or 20 when dependent on Claim 17, wherein said storage position is defined between said movable floor members when said pivotable floor members are in their said storage position.
22. A portable building unit as claimed in any one of Claims 11 to 21, wherein said end walls are pivot connected with said roof by hinges, each hinge comprising a first mounting part secured to the roof and a second mounting part secured to a respective end wall and a plurality of elongate members pivot connected between said first and second mounting parts.
23. A portable building unit as claimed in any one of Claims 11 to 22, further comprising a locking arrangement for locking said end walls with respect to the roof when said end walls are in said upright use condition.
24. A portable building unit as claimed in Claim 23, wherein said locking arrangement is arranged to automatically lock as the end walls move into said upright use condition.
25. A portable building unit as claimed in Claim 23 or 24, wherein said locking arrangement comprises recesses fixed with respect to one of said roof and said end walls and respective locking members receivable in said recesses and fixed with respect to the other of said roof and said end walls.
26. A portable building unit as claimed in Claim 25 when dependent on Claim 22, wherein one of said recesses and said locking members is provided on said first mounting parts and the other of said recesses and said locking members is provided on said second mounting parts.
27. A portable building unit as claimed in any one of Claims 11 to 26, further comprising respective sealing arrangements for sealing between the end walls and the roof, said sealing arrangements being arranged to automatically form respective seals as the end walls move into said upright use condition.
28. A portable building unit as claimed in Claim 27, wherein said sealing arrangements comprise seals mounted on the respective end walls and respective sealing surfaces

provided on the roof and co-operable with said seals for sealing between the end walls and the roof.

29. A kit comprising a portable building unit as claimed in any one of Claims 11 to 28 and an erection mechanism for moving the roof away from said base.
30. A kit as claimed in Claim 29, wherein said erection comprises two erection masts releasably securable to the base such that each is pivotable relative to the base about an axis extending substantially parallel to said end walls.
31. A kit as claimed in Claim 30, wherein each mast comprises a sliding member slideable along the mast and secured to a respective lifting cable that turns over a member that is secured to the mast at a distance from the base greater than the height of the portable building unit when in said upright use condition.
32. A kit as claimed in Claim 30, further comprising a drive mechanism for drawing said cables over the respective member to cause said sliding members to slide along said masts towards the respective members.
33. A building comprising two portable building units as claimed in any one of Claims 11 to 28 disposed in side by side relation and with the respective end walls thereof in said upright use condition.
34. A method of erecting a portable building unit from a collapsed storage condition, said portable building unit comprising a base, roofing, at least one first connecting member connecting between a first end region of the roofing and the base and at least one second connecting member connecting between a second end region of the roofing and the base and the method comprising applying a first force that causes said first end region of the roofing to lift with respect to the base and said at least one first connecting member to move from a collapsed condition to a finish position with respect to said roofing and thereafter applying a second force that causes said second end region of the roofing to lift with respect to the base and said at least one second connecting member to move from a collapsed condition to a finish position with respect to said roofing.
35. A method as claimed in Claim 34, wherein movement of said at least one second connecting member to said finish position brings said at least one second connecting

- member and said least one first connecting member to a finish position with respect to said base.
36. A method as claimed in Claim 35, wherein when in said finish positions, said at least one first connecting member and said at least one second connecting member support said roofing on said base.
37. A method as claimed in Claim 35 or 36, further comprising moving flooring provided on said base into a position in which it substantially prevents movement of the first and second connecting members from their finish positions with respect to the base.
38. A method as claimed in Claim 37, wherein said flooring comprises respective pivotable flooring portions having an end adjacent said first and second connecting members and moving the flooring into a position in which it substantially prevents said movement of the first and second connecting members comprises causing pivoting movement of said flooring portions.
39. A method as claimed in Claim 38, wherein said flooring further comprises further flooring portions pivotably connected to said pivotable flooring portions and said method further comprises pivoting said further flooring portions from a storage position in which they overlie said pivotable flooring portions to a position in which they extend from said pivotable flooring portions to provide a substantially continuous floor extending over said base.
40. A method as claimed in any one of Claims 34 to 38, wherein said at least one first connecting member forms an end wall of the portable building unit and said at least one second connecting member forms a second end wall of the portable building unit.
41. A method as claimed in any one of Claims 34 to 40, wherein said lifting force applied to said first end region of the roofing causes said at least one first connecting member to pivot with respect to the base and the roofing and slide with respect to one of said base roofing and said lifting force applied to said second end of the roofing causes said at least one second connecting member to pivot with respect to the base and the roofing and slide with respect to one of said base and said roofing.
42. A method as claimed in any one of Claims 34 to 41, wherein said first and second forces are lifting forces applied directly to said roof.

43. A method as claimed in any one of Claims 36 to 42 when dependent on Claim 35, wherein said portable building unit comprises a side wall pivot connected to said base, the method comprising raising the side wall from a storage position to an upright position by pivoting the side wall with respect to the base.
44. A method as claimed in Claim 43, wherein said side wall comprises a plurality of connected members movable with respect to one another between a storage condition in which the members overlie one another and a use position in which they are disposed generally side by side, the method comprising moving said members from said storage condition to said use position by a pivoting movement after said side wall has been raised to said upright position.
45. A method as claimed in any one of Claims 34 to 45, wherein prior to applying said first force, said roofing is caused to make a generally planar sliding movement with respect to said base.
46. A method as claimed in claim 45, wherein said at least one connecting member and said at least one second connecting member make said generally planar movement with said roofing.
47. A portable building unit substantially as herein described with reference to the drawings.
48. A method of erecting a portable building unit substantially as herein described with reference to the drawings.

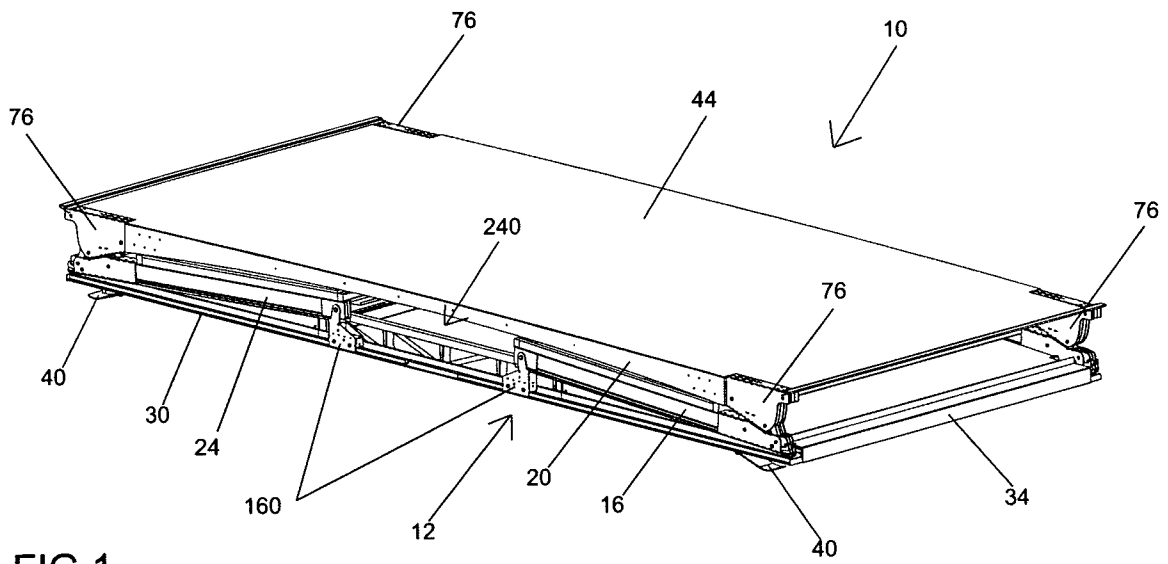

FIG 1

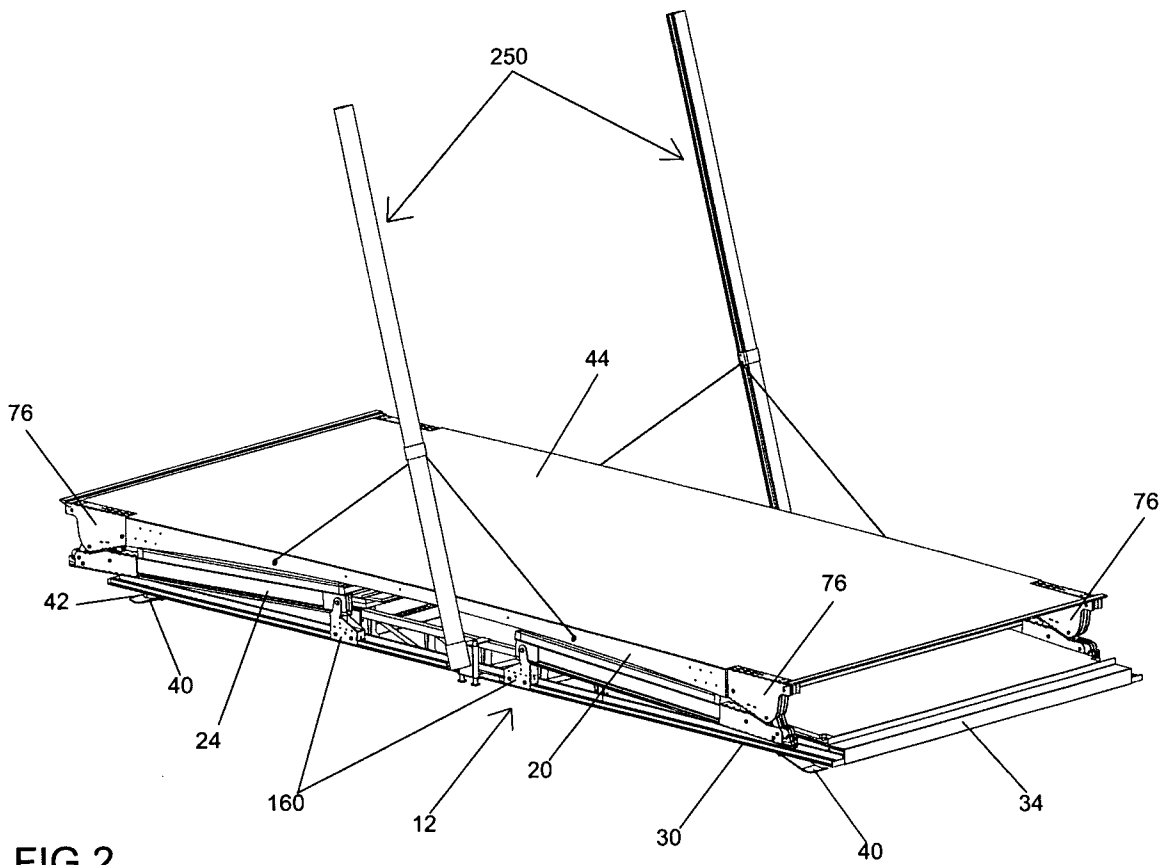

FIG 2

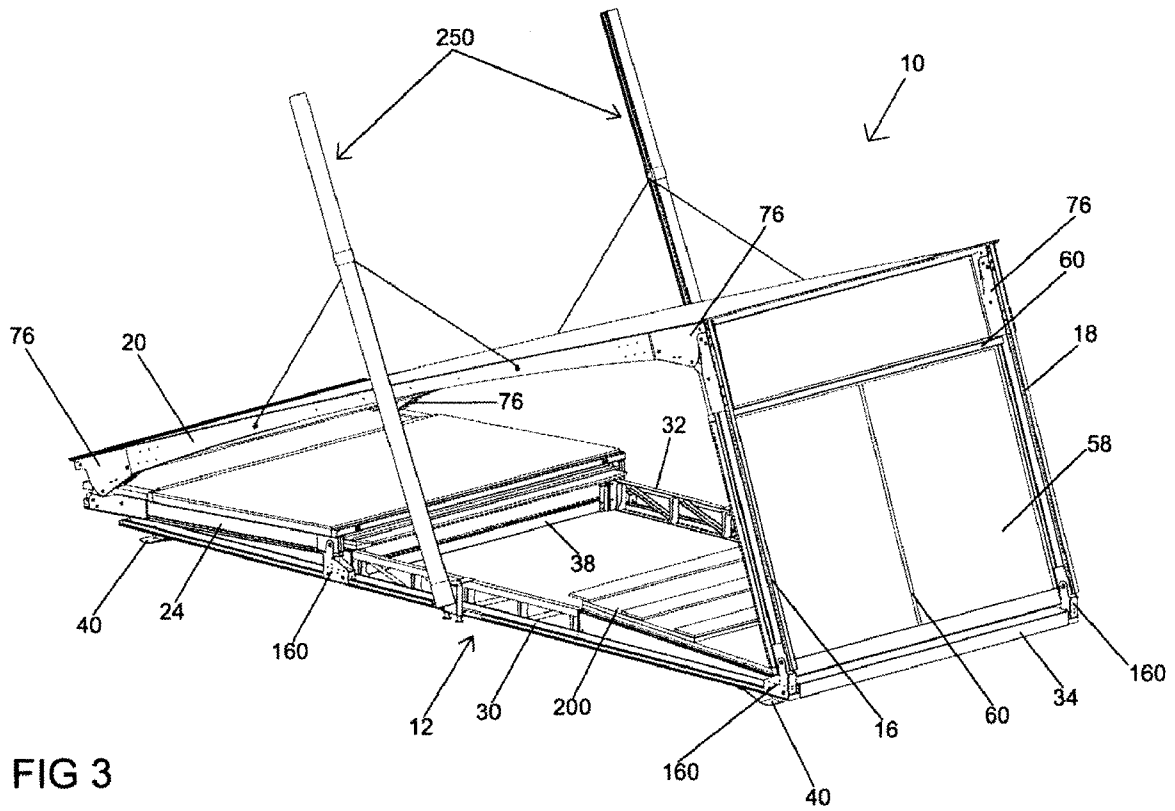

FIG 3

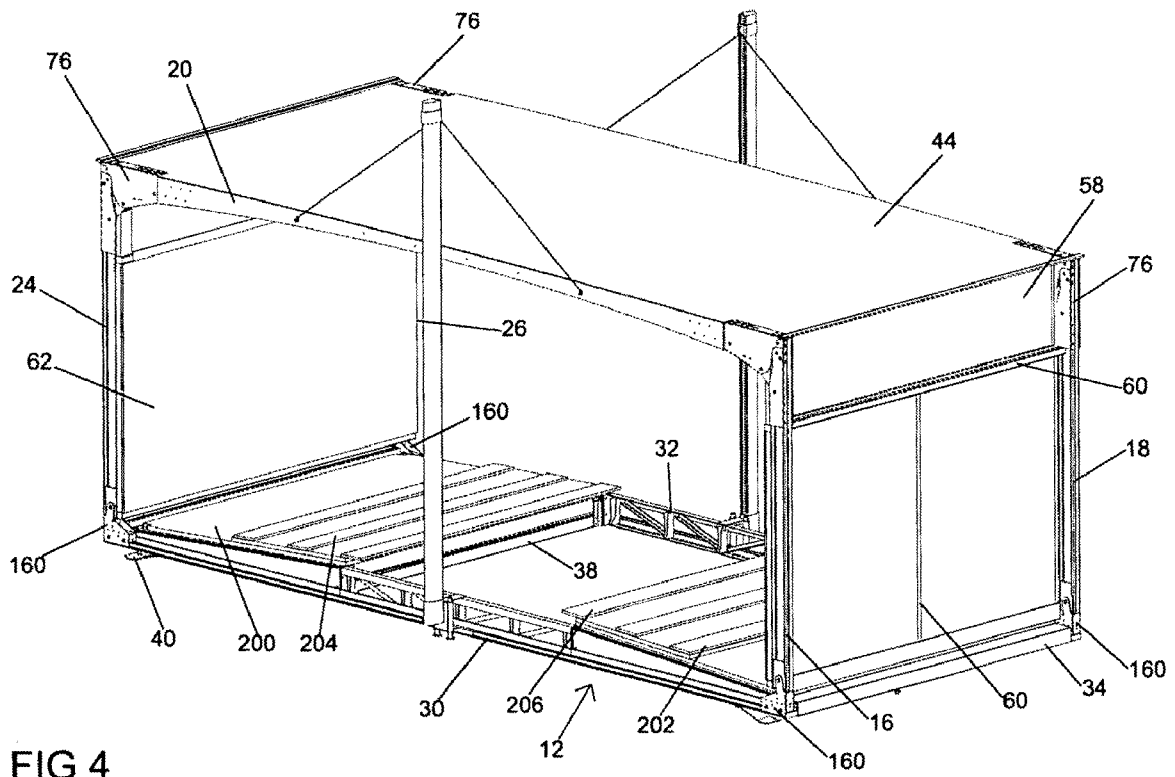

FIG 4

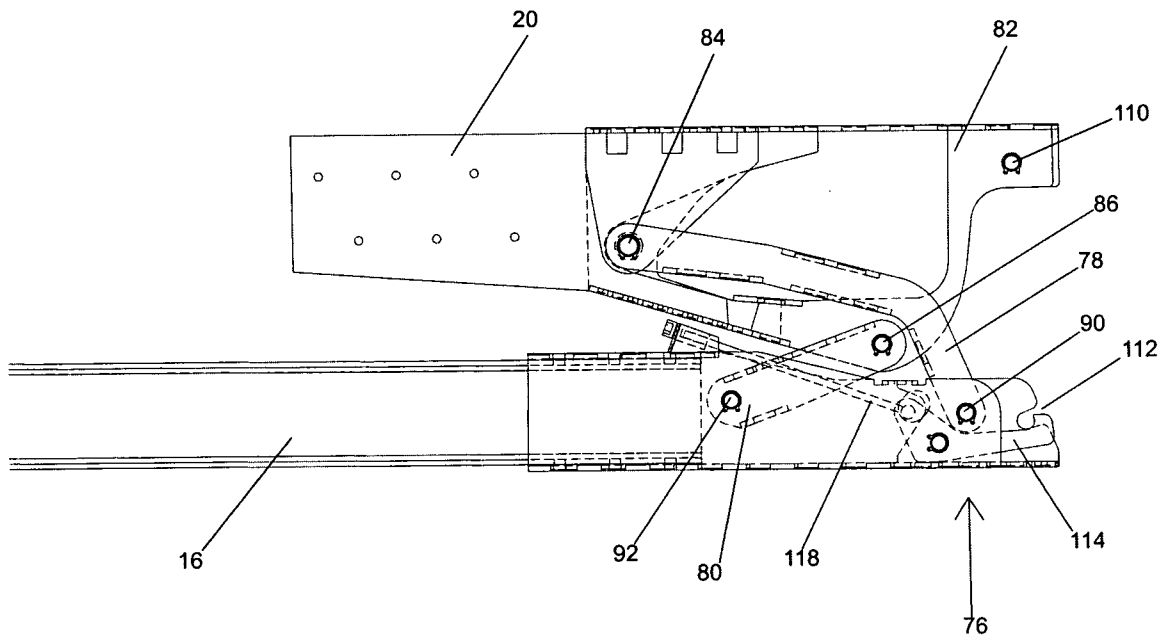

FIG 5

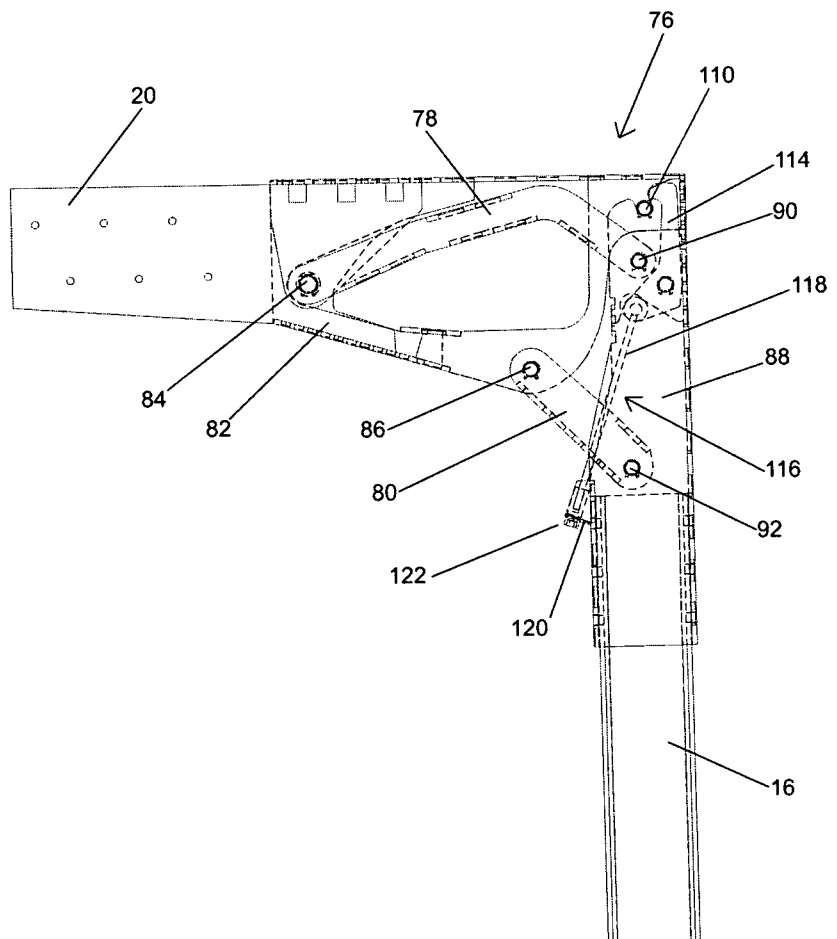

FIG 6

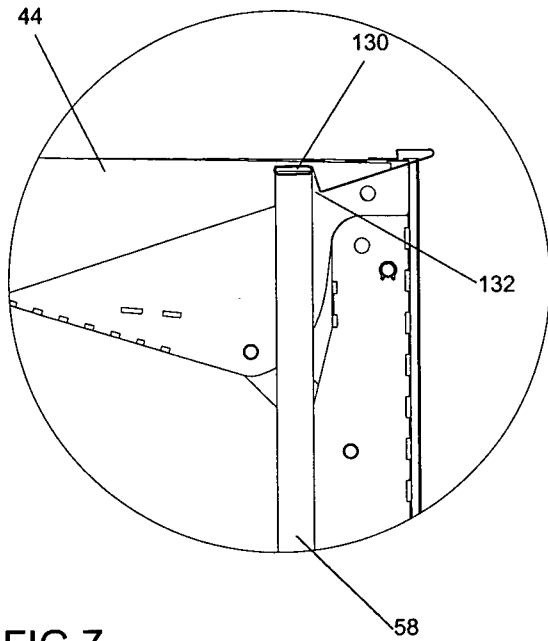

FIG 7

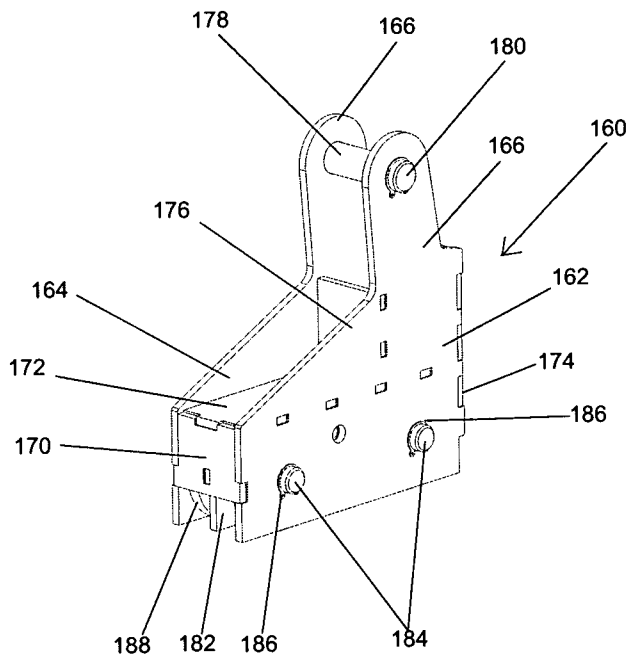

FIG 8

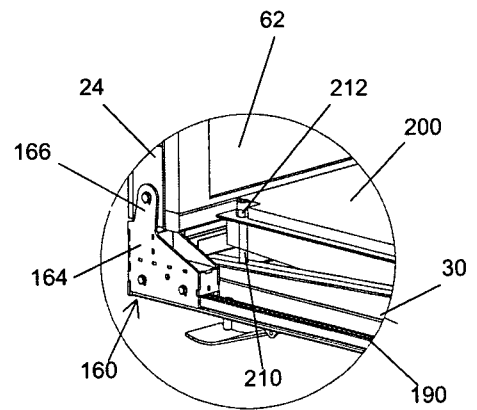

FIG 9

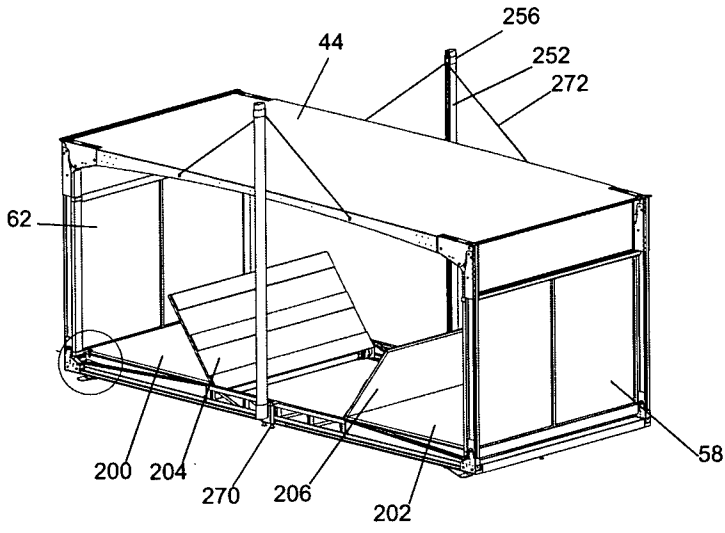

FIG 10

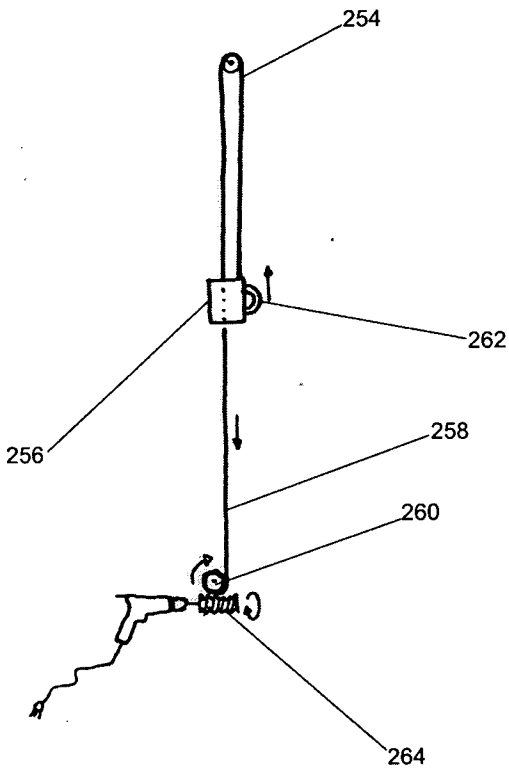

FIG 11

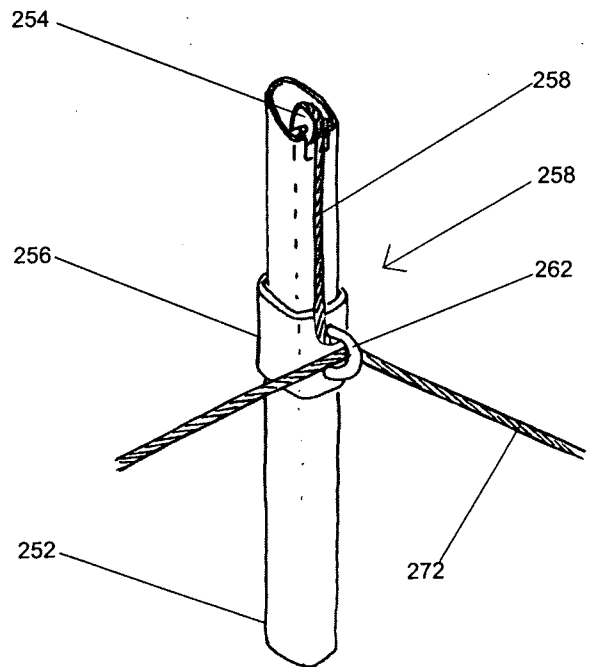

FIG 12

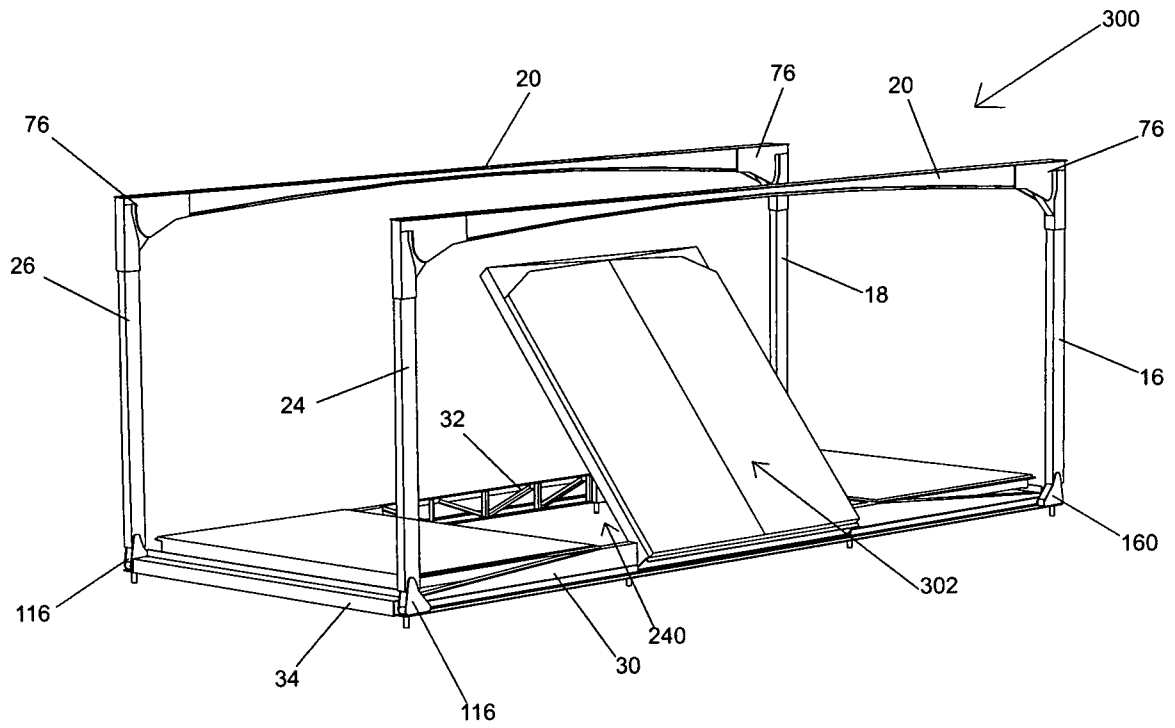

FIG 13

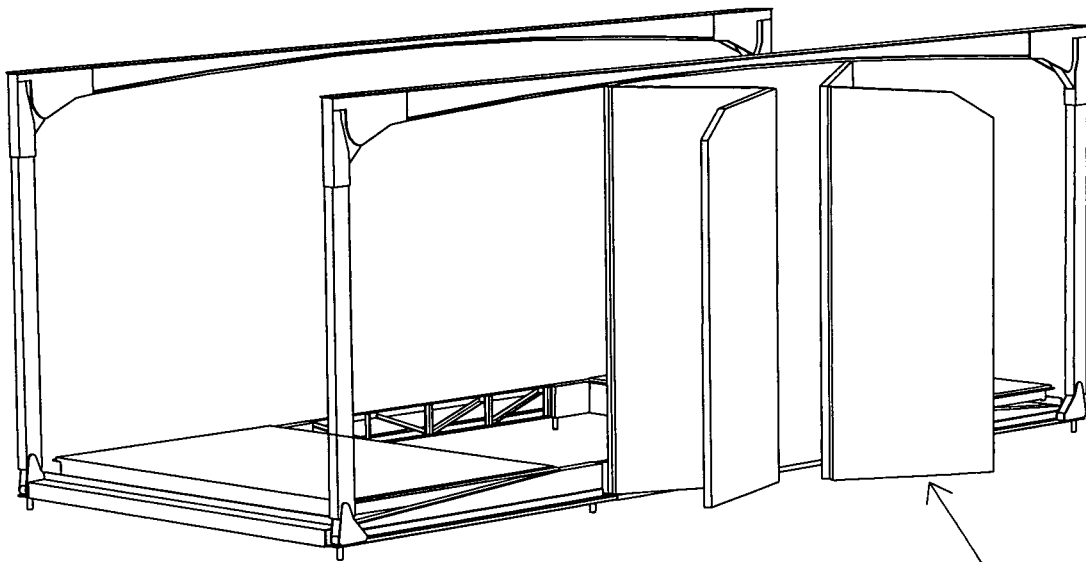

FIG 14

