

(12) INTERNATIONAL APPLICATION PUBLISHED UNDER THE PATENT COOPERATION TREATY (PCT)

(19) World Intellectual Property Organization
International Bureau



(43) International Publication Date
25 September 2003 (25.09.2003)

PCT

(10) International Publication Number
WO 03/078214 A1

(51) International Patent Classification⁷: **B60R 21/16**

(21) International Application Number: PCT/SE03/00345

(22) International Filing Date: 4 March 2003 (04.03.2003)

(25) Filing Language: English

(26) Publication Language: English

(30) Priority Data:
0206455.8 19 March 2002 (19.03.2002) GB

(71) Applicant (for all designated States except US): **AUTO-LIV DEVELOPMENT AB** [SE/SE]; S-477 83 Vårgårda (SE).

(72) Inventors; and

(75) Inventors/Applicants (for US only): **JOHANSSON, Jack** [SE/SE]; Bårhult 616, S-438 91 Landvetter (SE). **WARM, Annika** [SE/SE]; Borgarparken 6, S-442 32 Kungälv (SE).

(74) Agent: **MEULLER, Erik**; Autoliv Development AB, S-447 83 Vårgårda (SE).

(81) Designated States (national): AE, AG, AL, AM, AT, AU, AZ, BA, BB, BG, BR, BY, BZ, CA, CH, CN, CO, CR, CU, CZ, DE, DK, DM, DZ, EC, EE, ES, FI, GB, GD, GE, GH, GM, HR, HU, ID, IL, IN, IS, JP, KE, KG, KP, KR, KZ, LC, LK, LR, LS, LT, LU, LV, MA, MD, MG, MK, MN, MW, MX, MZ, NO, NZ, PL, PT, RO, RU, SD, SE, SG, SK, SL, TJ, TM, TR, TT, TZ, UA, UG, US, UZ, VN, YU, ZA, ZW.

(84) Designated States (regional): ARIPO patent (GH, GM, KE, LS, MW, MZ, SD, SL, SZ, TZ, UG, ZM, ZW), Eurasian patent (AM, AZ, BY, KG, KZ, MD, RU, TJ, TM), European patent (AT, BE, BG, CH, CY, CZ, DE, DK, EE, ES, FI, FR, GB, GR, HU, IE, IT, LU, MC, NL, PT, RO, SE, SI, SK, TR), OAPI patent (BF, BJ, CF, CG, CI, CM, GA, GN, GQ, GW, ML, MR, NE, SN, TD, TG).

Published:

— with international search report

For two-letter codes and other abbreviations, refer to the "Guidance Notes on Codes and Abbreviations" appearing at the beginning of each regular issue of the PCT Gazette.

(54) Title: AN AIR-BAG

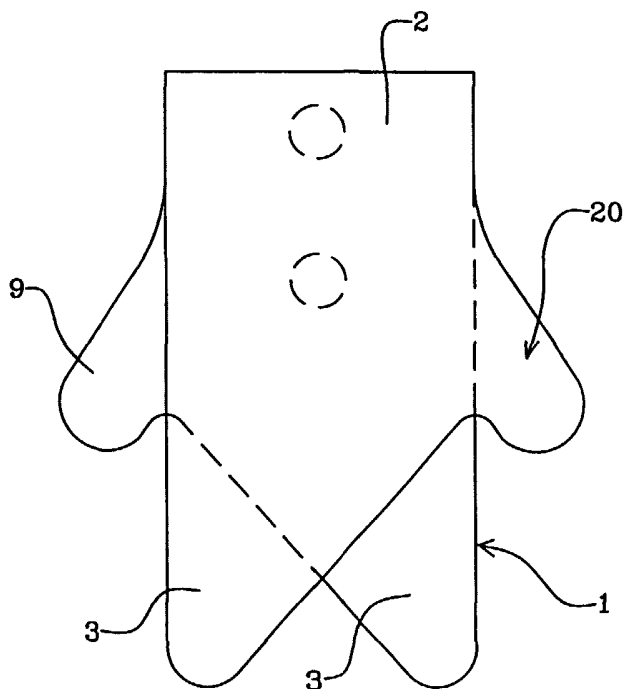

(57) Abstract: An air-bag is formed using two substantially identical, but inverted, fabric elements (1). Each element defines a generally rectangular region (2) having, at one narrow end thereof, a generally triangular extension (3), one side (4) of which is co-extensive with one side (5) of the rectangular region (2). The other side (8) of the rectangular region has a triangular or thumb-like projection (9). The two elements are substantially superimposed with the rectangular regions (2) thereof aligned. If the ends of the rectangular regions carrying the triangular extensions (3) are separated, the projections or thumbs (9) may be folded to form side-walls, and the triangular projections (3) may be folded inwardly to form an end region. A single peripheral seam may seal the two elements together to form an air-bag.

WO 03/078214 A1

5

“AN AIR-BAG”

10 **THE PRESENT INVENTION** relates to an air-bag, and more particularly relates to an air-bag intended to protect an occupant of a motor vehicle in the event that an accident should occur.

15 Many different designs of air-bag have been proposed for use in protecting passengers in motor vehicles. Some air-bags are formed using two identical sheets or layers of fabric which are simply superimposed and connected by a peripheral seam. The air-bag, before folding and inflation, can therefore be spread out to be perfectly flat. Air-bags of this type are frequently used as a driver's air-bag, the air-bag being mounted within the hub of a
20 steering wheel. Initially the fabric layers are substantially circular and thus, when the air-bag is inflated, the air-bag has a generally spherical form.

In order to protect the occupant of the passenger seat adequately, a bag has to be provided which must move a substantial distance into the passenger
25 compartment, since a conventional passenger bag is initially stored in a housing present in the dashboard of a vehicle, which is further from the passenger than the steering wheel is from the driver. It has therefore been the practice to

5 fabric which comprise two side pieces, and at least one middle piece which connects the two side pieces. Typically such an air-bag, when spread out uninflated, will partly stand up. The fabrication of such an air-bag requires much work cutting out the pieces, and also much work in sewing the pieces together. Consequently these air-bags are expensive to manufacture.

10 US-A-5,454,594 describes a three-dimensional air-bag which is formed from two pieces of fabric which are interconnected using one continuous seam. The two pieces of fabric are not identical, and the resultant air-bag has a seam pattern which is reminiscent of that of a tennis ball. It is not practicable to cut the pieces of fabric from a single sheet of fabric without substantial wastage.

15 WO99/46149 discloses an air-bag made from a single element of fabric which comprises two mirror-image portions interconnected by a fold-line. Again it is difficult to cut fabric elements for use in forming air-bags of this type from a single sheet without substantial wastage of fabric.

The present invention seeks to provide an improved air-bag.

20 According to this invention there is provided an air-bag, the air-bag comprising two fabric elements of corresponding, but inverted design, each fabric element defining a generally rectangular region having, at one end thereof, a generally triangular extension, the extension having one side thereof substantially contiguous with one side of the rectangular region, the element 25 having a projection extending outwardly from the other side of the rectangular region, the two elements being located adjacent each other with the rectangular regions thereof substantially superimposed, and with the projections provided

the rectangular region of the other element forming a front wall, the projections forming side-walls interconnecting the front wall and the rear wall, and the triangular regions being inter-engaged to form an end region of the air-bag.

5 Preferably each projection has a linear edge extending from the relevant side of the rectangular area at a point spaced from the end thereof, the linear edge being complemented by a terminal region which terminates substantially at a corner of the rectangular area.

10 In one embodiment the terminal region is curved.

 Preferably the air-bag, when inflated, is substantially "drop"-shaped.

15 In an alternative embodiment the projection is of generally triangular form.

 Conveniently the air-bag, when inflated, is generally triangular-shaped.

20 Preferably the air-bag is provided with a gas inlet hole formed in one of the fabric layers.

 Alternatively a gas inlet hole is formed in the seam.

25 In order that the invention may be more readily understood, and so that further features thereof may be appreciated, the invention will now be described, by way of example, with reference to the accompanying drawings in which:

4

FIGURE 1 is a view of a first fabric element,

FIGURE 2 is a view of a second fabric element,

5 FIGURE 3 is a view of the fabric elements when superimposed as an initial stage during the fabrication of an air-bag,

FIGURE 4 is a perspective view of an air-bag made from the fabric elements of Figures 1 to 3,

10

FIGURE 5 is a view illustrating a modified embodiment of the invention, and

FIGURE 6 is a view of a sheet of fabric showing a cutting pattern for cutting elements to be used to form a further embodiment of the invention.

15

Referring initially to Figure 1 of the accompanying drawings, a fabric element 1 is illustrated. The fabric element 1 has a main rectangular region 2. Extending from one end of the main rectangular region 2 is a generally triangular extension 3. The triangular extension 3 has one side 4 thereof contiguous with one side 5 of the rectangle, and another side 6 thereof which terminates adjacent the end of the other side of the rectangle. The apex 7, between these two sides 4, 6 is rounded. Extending from that other side 8 of the rectangle is an inclined projection or "thumb" 9. The projection 9 has a substantially linear edge 10 which extends away from the rectangle from a point 11 part-way along the relevant side 8 thereof. The linear side 10 terminates with an inwardly curved terminal region 12 which curves inwardly

20
25

of the triangular portion is recessed in a curved manner that emulates the rounded apex 7 of the triangular extension 3. The fabric element 1 has a shape resembling that of a mitten.

5 A fabric element 1 is shown provided with an aperture 15 adjacent the end 16 of the rectangular region 2 remote from the extension 3. The aperture 15 is adapted to receive a gas generator or the like. The fabric element 1 also has a vent opening 17 provided in a central area 18 of the rectangular portion 2.

10

Figure 2 illustrates a fabric element 20 which is effectively the mirror image of the fabric element 1, but without the apertures therein. The fabric element 20 may indeed be an element that is identical with the fabric element 1, but which has simply been inverted or turned over. The elements are thus of
15 inverted design.

The two fabric elements 1 and 20 may be substantially superimposed, with the rectangular regions of the elements being co-aligned. This is the situation shown in Figure 3. With the fabric elements in this configuration,
20 the projection or thumb 9 of the fabric element 1, which is the lower fabric element, protrudes from one side, whereas the corresponding projection or thumb 9 of the element 20, which is the upper element, projection the other side.

25 The upper fabric element 20 is then peeled back slightly from the lower fabric element 1, starting at the end of the fabric element 20, constituted by the triangular protrusion 3. The fabric element 20 thus becomes a front wall which

notional fold-line which is coincident with the edge of the rectangle 2, whilst the projection or thumb 9 of the lower fabric element 1 may simultaneously be folded upwardly. The projections or thumbs 9 then effectively form side-walls interconnecting the front wall and the rear wall. The triangular projection 3 of the upper fabric element 20 may then be folded generally downwardly, whilst simultaneously the triangular projection 3 of the lower fabric element 1 is folded upwardly, and the two triangular regions will then engage in a cooperating manner to define an end region 21. A single seam may be provided which interconnects the adjacent edges of the elements 1 and 20 when in the condition described, to produce a "three-dimensional" air-bag.

Figure 4 illustrates the air-bag with the upper fabric element 20 being shown shaded, for ease of identification. It can be seen that the air-bag presents a front wall defined by the fabric element 20, and a rear wall defined by the fabric element 1, and two side-walls defined by the projections 9. The interconnected triangular regions 3 form a "drop"-shaped end region 21 for the air-bag. The bag is thus of drop-shaped form.

Figure 5 illustrates a modified embodiment of the invention in which the end region of the air-bag is somewhat flatter than that shown in Figure 4. The air-bag is thus of triangular form.

In this embodiment the projection or "thumb" is generally triangular, the curved terminal region 12 of the embodiment of Figures 1 to 4 being replaced by a straight side.

Figure 6 illustrates a sheet of fabric 30 illustrating the cutting pattern

each identical. The repeat 31 comprises four substantially identical elements 32, 33, 34, 35, each element presenting a rectangular portion 36 with a generally triangular projection 37 at one end thereof, and a further projection or "thumb" 38 provided at one side thereof. In each case a corner of the rectangular region 36 is provided at a corner of the repeat 31. It can be seen that the four elements can be cut from a single sheet of fabric with a minimum of wastage. An air-bag of the type described may be used as a passenger air-bag, or may be used as a roof-mounted air-bag.

Whilst the invention has been described with reference to an embodiment in which an aperture 15 is provided within one fabric component to receive a gas generator and to act as a gas inlet hole, in an alternative arrangement the aperture could be defined by part of the peripheral seam.

In an alternative embodiment the air-bag may be used as a driver air-bag, and in such a situation the aperture to receive the air-bag will be located within the central region 18 of the rectangular part of the one fabric layer.

It is to be understood that by altering the relative sizes of the triangular region 3 and the projection 9 of each fabric layer, air-bags of different final configuration may be produced. The length of the first side 5 of the rectangular element 1 together with the length of the contiguous side 4 of the triangular portion 3 should be the same as the length of the other side 8 of the rectangle, as far as the origin 11 of the linear side 10 of the projection 9, and the length of the periphery of the projection 4 so that, when the two described elements are joined together, the free apex of the triangular portion 3 of one fabric element is neatly received within the cusp formed between the projection 9 and the

Whilst, as is clear from the foregoing description, it is particularly advantageous to fabricate an air-bag from two separate fabric elements, an air-bag in accordance with the invention can be made from a single fabric element
5 having two regions interconnected by a fold-line, the element having a configuration equivalent to that of two elements of the type generally described above located adjacent each other with the bases of the rectangular regions lying adjacent each other to form the fold-line.

10 In the present Specification "comprises" means "includes or consists of" and "comprising" means "including or consisting of".

CLAIMS:

- 5 1. An air-bag, the air-bag comprising two fabric elements of corresponding, but inverted design, each fabric element defining a generally rectangular region having, at one end thereof, a generally triangular extension, the extension having one side thereof substantially contiguous with one side of the rectangular region, the element having a projection extending outwardly
10 from the other side of the rectangular region, the two elements being located adjacent each other with the rectangular regions thereof substantially superimposed, and with the projections provided on opposed sides thereof, the elements being interconnected by means of a peripheral seam, the rectangular region of one element forming a rear wall, and the rectangular region of the
15 other element forming a front wall, the projections forming side-walls interconnecting the front wall and the rear wall, and the triangular regions being inter-engaged to form an end region of the air-bag.
2. An air-bag according to Claim 1 wherein each projection has a linear
20 edge extending from the relevant side of the rectangular area at a point spaced from the end thereof, the linear edge being complemented by a terminal region which terminates substantially at a corner of the rectangular area.
3. An air-bag according to Claim 1 wherein the terminal region is curved.
25
4. An air-bag according to Claim 3 wherein the air-bag, when inflated, is substantially "drop"-shaped.

5. An air-bag according to any one of Claims 1 to 2 wherein the projection is of generally triangular form.
6. An air-bag according to Claim 5 wherein the air-bag, when inflated, is
5 generally triangular-shaped.
7. An air-bag according to any one of the preceding Claims provided with a gas inlet hole formed in one of the fabric layers.
- 10 8. An air-bag according to any one of Claims 1 to 7 wherein a gas inlet hole is formed in the seam.

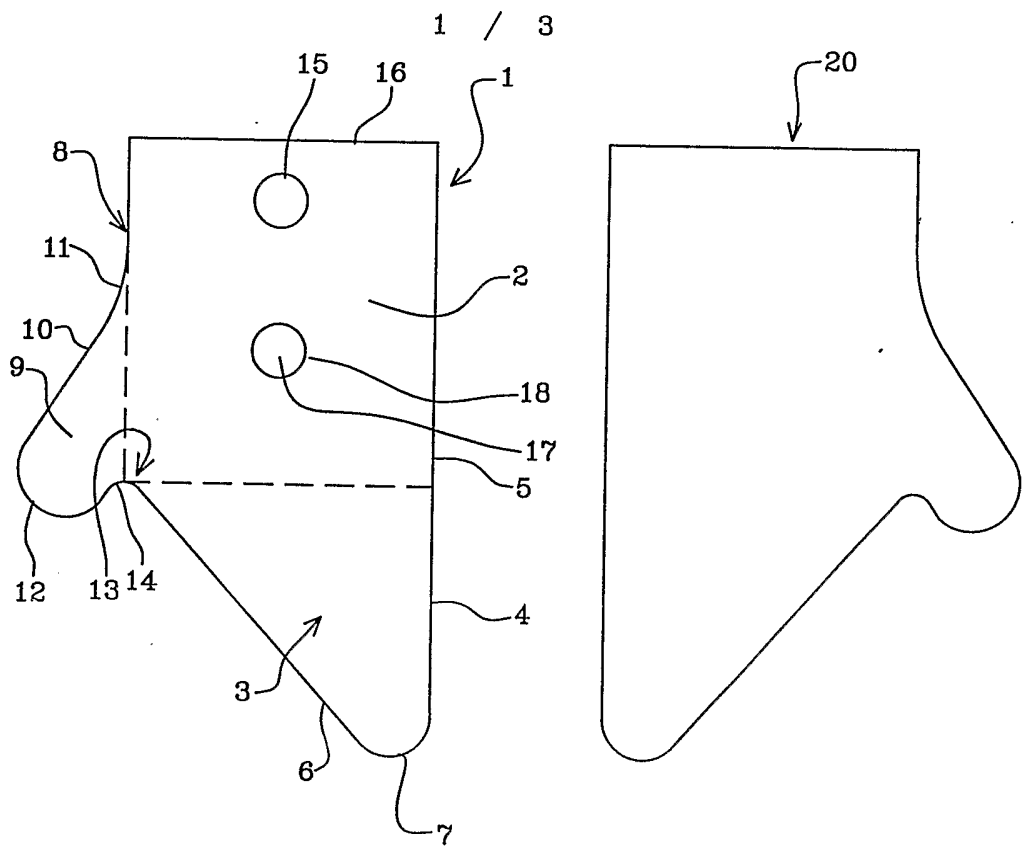

FIG 1

FIG 2

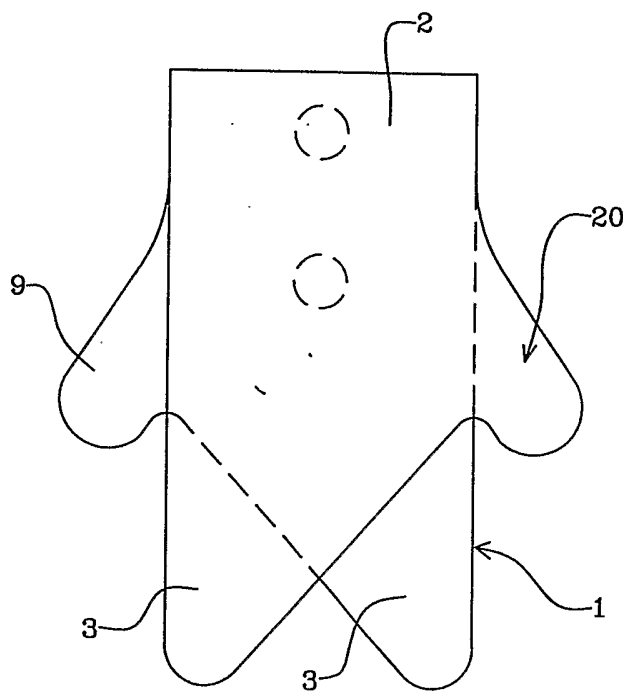

FIG 3

2 / 3

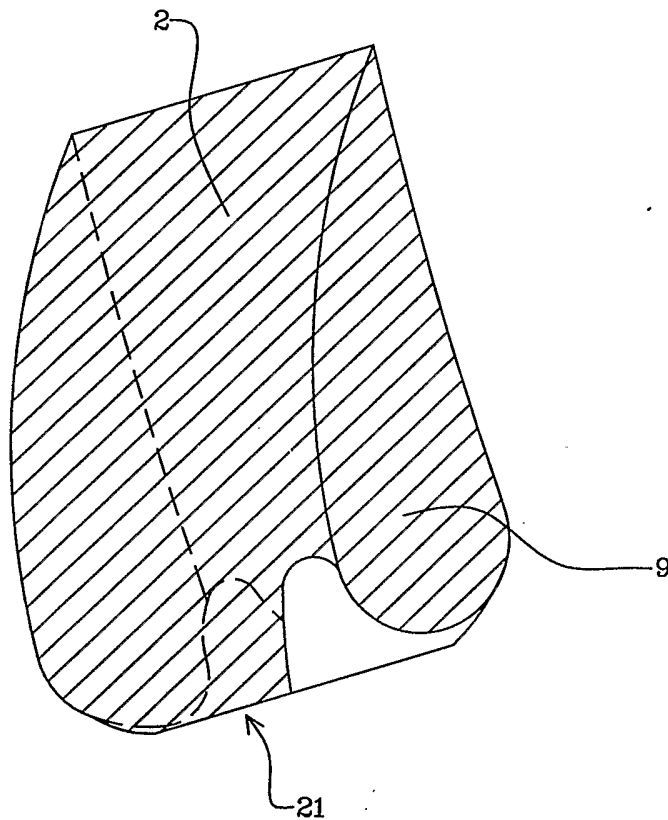

FIG 4

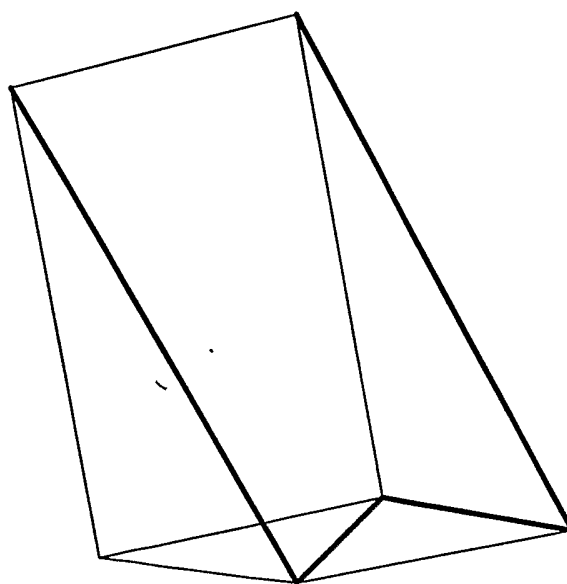

FIG 5

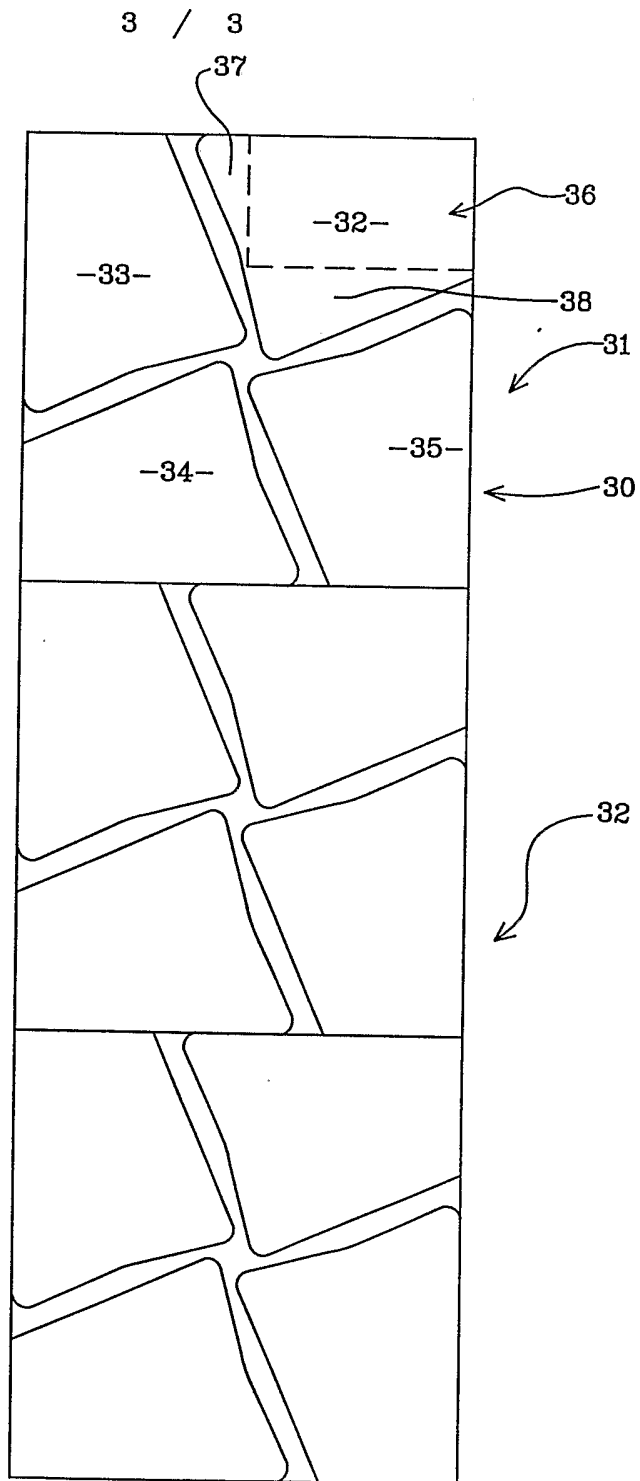

FIG 6

INTERNATIONAL SEARCH REPORT

International application No.

PCT/SE 03/00345

A. CLASSIFICATION OF SUBJECT MATTER

IPC7: B60R 21/16

According to International Patent Classification (IPC) or to both national classification and IPC

B. FIELDS SEARCHED

Minimum documentation searched (classification system followed by classification symbols)

IPC7: B60R

Documentation searched other than minimum documentation to the extent that such documents are included in the fields searched

SE,DK,FI,NO classes as above

Electronic data base consulted during the international search (name of data base and, where practicable, search terms used)

EPO-INTERNAL, WPI DATA, PAJ

C. DOCUMENTS CONSIDERED TO BE RELEVANT

Category*	Citation of document, with indication, where appropriate, of the relevant passages	Relevant to claim No.
A	EP 0955215 A2 (TAKATA CORP), 10 November 1999 (10.11.99) --	1-8
A	WO 0216174 A1 (MILLIKEN & COMPANY), 28 February 2002 (28.02.02) --	1-8
A	US 5855393 A (KESHAVARAJ), 5 January 1999 (05.01.99) --	1-8
A	US 5944342 A (WHITE, JR ET AL), 31 August 1999 (31.08.99) -- -----	1-8

Further documents are listed in the continuation of Box C.

See patent family annex.

* Special categories of cited documents:

"A" document defining the general state of the art which is not considered to be of particular relevance

"E" earlier application or patent but published on or after the international filing date

"L" document which may throw doubts on priority claim(s) or which is cited to establish the publication date of another citation or other special reason (as specified)

"O" document referring to an oral disclosure, use, exhibition or other means

"P" document published prior to the international filing date but later than the priority date claimed

"T" later document published after the international filing date or priority date and not in conflict with the application but cited to understand the principle or theory underlying the invention

"X" document of particular relevance: the claimed invention cannot be considered novel or cannot be considered to involve an inventive step when the document is taken alone

"Y" document of particular relevance: the claimed invention cannot be considered to involve an inventive step when the document is combined with one or more other such documents, such combination being obvious to a person skilled in the art

"&" document member of the same patent family

Date of the actual completion of the international search

26 May 2003

Date of mailing of the international search report

06-06-2003

Name and mailing address of the ISA/

Swedish Patent Office

Box 5055, S-102 42 STOCKHOLM

Facsimile No. +46 8 666 02 86

Authorized officer

Hans Nordström/EK

Telephone No. +46 8 782 25 00

INTERNATIONAL SEARCH REPORT

Information on patent family members

29/04/03

International application No.

PCT/SE 03/00345

Patent document cited in search report	Publication date	Patent family member(s)	Publication date
EP 0955215 A2	10/11/99	JP 2000025544 A US 6168203 B	25/01/00 02/01/01
WO 0216174 A1	28/02/02	AU 8341701 A US 2002020998 A	04/03/02 21/02/02
US 5855393 A	05/01/99	AU 9200998 A EP 0930987 A JP 2001505161 T US 5931498 A WO 9908903 A	08/03/99 28/07/99 17/04/01 03/08/99 25/02/99
US 5944342 A	31/08/99	DE 19848592 A GB 2330559 A,B GB 9821376 D	17/06/99 28/04/99 00/00/00