

(No Model.)

J. P. SIMMONS.
STEAM BOILER.

No. 415,303.

Patented Nov. 19, 1889.

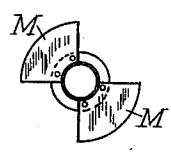
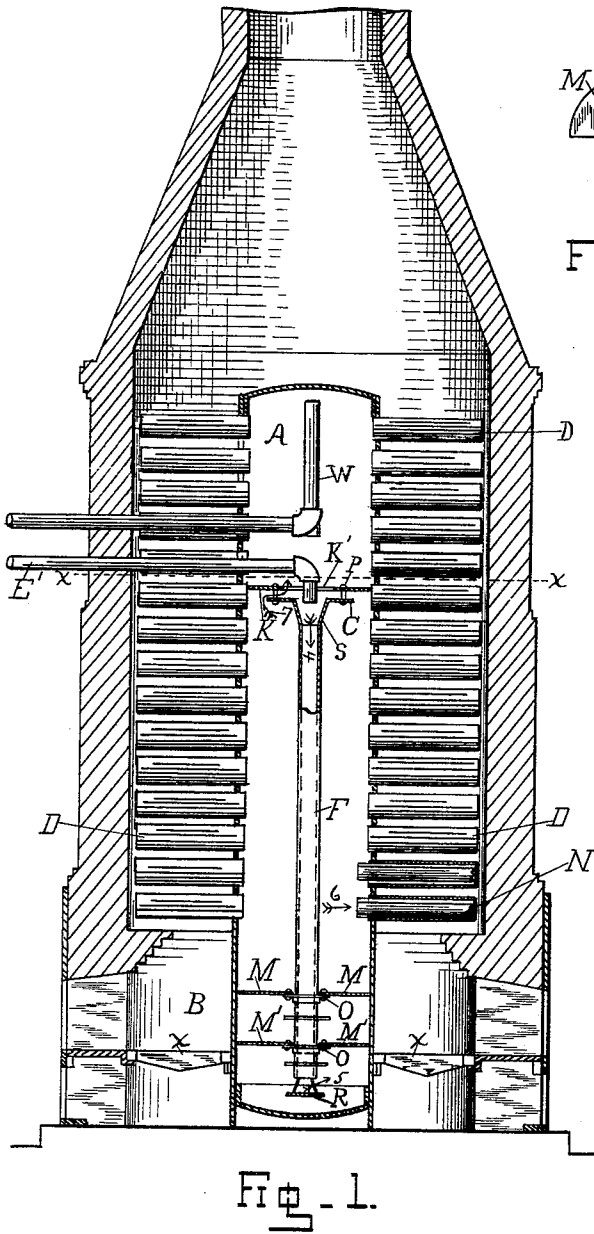

Fig. 2.

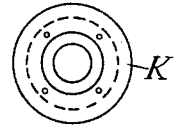

Fig. 3.

Fig. 4.

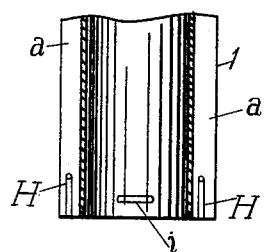
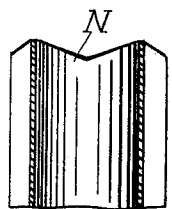
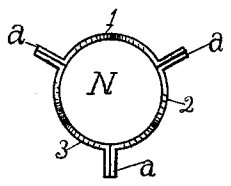

Fig. 5.

WITNESSES.

M. C. Galen
A. P. K. Beck

INVENTOR.

John P. Simmons

UNITED STATES PATENT OFFICE.

JOHN P. SIMMONS, OF LOS ANGELES, CALIFORNIA.

STEAM-BOILER.

SPECIFICATION forming part of Letters Patent No. 415,303, dated November 19, 1889.

Application filed April 24, 1889. Serial No. 308,496. (No model.)

To all whom it may concern:

Be it known that I, JOHN P. SIMMONS, a citizen of the United States, residing at Los Angeles, in the county of Los Angeles and State of California, have invented a new and useful Improvement in Sectional Steam-Boilers, of which the following is a full, clear, and exact description, reference being had to the accompanying drawings, forming part of this specification.

Figure 1 represents a central vertical section of my improved boiler with its furnace set in masonry. Fig. 2 represents segmental shelves for the collection and removal of sediment and scale. Fig. 3 represents the upper end of the centrally-arranged water-circulating tube, with its flange and the open diaphragm to which it is connected at the top. Fig. 4 represents the removable interior radial circulating-tubes, and Fig. 5 represents one of the three sections of the same detached.

The primary objects of my present invention are to provide means which will more effectively promote the circulation of the water in steam-boilers and for separating and removing sediment and scale from the boiler.

My improvements relate to and are combined with boilers of that class denominated the "porcupine" or "sectional" boilers. The lower end of the boiler A is set down in the furnace B, provided with grate-bars *x* and doors, in the usual manner, and has connected to and radiating from it tubes D, closed at their outer ends, but open and communicating with it at their connected inner ends. These tubes, which constitute a portion of the water-space of the boiler, stand out laterally in the combustion-chamber of the furnace, which surrounds the boiler, and receive the more intense heat generated by the burning fuel.

Within tubes D, I have applied water-circulating tubes N, formed in three segmental sections, with radiating flanges *a*, bolted together, as shown in Fig. 4. Their outer ends are undulating or scalloped to allow the water to circulate within and between them and the radiating tubes D, and their inner ends project into the boiler A to such an extent as to accelerate the circulation of the water, which, being heated to a higher degree within the annular space between the removable cir-

culating water-tubes N and tubes D, will pass out into boiler A, and the less-heated water in the latter will pass into the removable tubes N, and thus a continuous circulation will be enforced by the unequally-heated water.

Diaphragm K, connected to the interior of boiler A, has a circular opening K', equal to two-thirds of its diameter, and the annular plate C, having a funnel S attached under it, is supported by several bolts P a short distance below the diaphragm K. The funnel S connects with the open upper end of the central circulating-pipe F, and the latter extends down nearly to the bottom of boiler A, and is provided with a deflecting-disk R, between which and the lower end of pipe F there is an open space, through which water introduced by pipe E' to feed the boiler will pass from tube F laterally into the boiler A. The water thus introduced from outside through feed-pipe E' commingles with heated water and descends through pipe F, thereby separating its impurities, and passes out laterally at the circular opening above deflecting-plate R, while the heated water in boiler A continuously ascends, being subjected to greater heat, and will pass up between annular plate C and diaphragm K, and thence through and above said diaphragm.

The water-line, or surface from which steam is evolved, is denoted by the dotted line *x x* in Fig. 1.

The flanges *a*, formed upon the sections 1 2 3 of the interior pipe N, will fit into the lateral pipes D and serve to divide any scale which forms upon the latter into three divisions, and when the tubes N are withdrawn from tubes D to be cleaned the scale deposited by the water upon the inner surfaces of tubes D may be more easily broken off and removed by reason thereof.

To prevent the inner tubes N from becoming immovably fastened to the tubes D by the scale deposited at each side of the flanges *a*, I have connected the flanges of the sections 1 2 3 by means of slots and removable bolts H at their inner ends only, (see Fig. 5,) so as to disconnect the sections at their projecting ends, and I have furnished each section with a lug *i*, by which it may be withdrawn separately from the other sections.

The segmental shelves M M' are connected by screws to flanged collars O around pipe F, and may be removed to be cleaned from sediment and scale. These removable segments ; or shelves M M' are arranged so that the two upper ones M are directly over the open spaces between the lower ones M' and at such a distance apart as to form zigzag passages for the circulating water, whereby they will serve
10 more effectively to collect the impurities in the water, which impurities will more readily lodge upon and adhere to them than to the upright surface of boiler A.

The arrows 4 5 6 7 indicate the circuit of the circulating water from the point of its entrance through feed-pipe E' until it returns to the surface or steam and water line at *xx*.

The space below the disk R at the bottom of pipe F serves as a receptacle for the
20 heavier impurities of the water.

It should be observed that the central pipe F is removable, with its appendages, to be cleaned from all impurities which will become deposited upon them, and as the water
25 which is introduced by pipe E' mixes with the heated water and in its descent becomes heated to a high degree the impurities it may contain will be deposited mainly inside of said tube at the bottom of the boiler and upon
30 the shelves M M' around said pipe F.

W denotes the steam-exit pipe.

When the water in boilers of this character is heated, that nearest the outside is caused to rise by the generating steam, and as it
35 reaches the water-line it falls toward the center of the boiler and into the pipe F, down which it flows to supply the vacuum caused by the ascending water. The pipe F separates the descending water from the ascending water, and thereby induces a perfect
40 circulation from top to bottom. Without this pipe the ascending and descending water mingle, thus preventing perfect circulation. The annular outwardly-projecting plate or flange
45 C intercepts the ascending water near the tube, so that its current will not obstruct the downward flow of water into the mouth of the tube.

The flange is preferably arranged in relation to diaphragm K so as to form a lateral passage between them. The diaphragm K, arranged
50 above flange C, prevents the water from rushing to the top of the boiler and directs it into the lateral passage between the two parts C and K. This prevents what is
55 known as "priming," as the ascending water is thereby caused to return down the pipe and cannot rise to enter the steam-pipe W. The deflecting-plate R at the bottom of the pipe F assists in the circulation by preventing
60 the upwardly-flowing water from entering the bottom of pipe E, and also by deflecting the downwardly-flowing water and thereby causing an eddy around the lower end of the pipe, thereby precipitating the

impurities which are in the water and allowing the same to deposit and remain undisturbed upon the bottom of the boiler. Said pipe F will, however, operate to promote the circulation in the boiler if the flange C and deflecting-plate R be removed. The length
70 of the pipe F may be varied; but such pipe should extend to near the bottom of the boiler and must not extend up to the water-line.

The essential feature of the portion of my invention calculated to produce a proper circulation within the boiler proper is an open vertical pipe or tube centrally located within the boiler and extending from below the water-line to near the bottom of the boiler.
80

Having described my invention, I claim and desire to secure by Letters Patent—

1. The central water-circulating pipe F, provided with annular flange C and funnel S at its top and lateral water passage-ways at its
85 bottom, in combination with the ingress water-pipe E' and open diaphragm K, between which and annular flange C the water can circulate, as described.

2. The water-circulating pipe F, connected
90 with the funnel S and annular flange or plate C, in combination with open diaphragm K and segmental removable shelves M M', arranged to form indirect passage-ways between them, substantially as described.
95

3. The feed-water pipe E', entering the boiler at the water-line *xx*, with the discharging-orifice arranged centrally in the opening of diaphragm K, to accelerate circulation and commingle the hot and cold water, in combination with annular plate C and pipe F, having lateral openings at its bottom, as specified.
100

4. The sectional removable projecting tubes N, provided with radial flanges *a*, open slot H, and lugs *i*, connected to their inner ends
105 by removable bolts, as and for the purpose specified.

5. In a steam-boiler substantially such as described, an open vertical pipe extending from below the water-line to near the bottom
110 of the boiler, and provided at its top with an annular outwardly-projecting flange arranged, as set forth, in a lower and upper plane, with lateral passages therebetween, the lower section or plane of said flange being
115 next the pipe.

6. In a steam-boiler substantially such as described, an open vertical pipe extending from below the water-line to near the bottom of the boiler, and provided at the top with an
120 annular outwardly-projecting flange, and provided at the bottom with the deflecting-plate R and lateral openings.

JOHN P. SIMMONS.

Witnesses:

H. P. K. PECK,
M. C. GALER.