



(51) International Patent Classification:
H03F 1/07 (2006.01)

(21) International Application Number:
PCT/CN2018/076225

(22) International Filing Date:
11 February 2018 (11.02.2018)

(25) Filing Language: English

(26) Publication Language: English

(71) Applicant: TELEFONAKTIEBOLAGET LM ERICSSON (PUBL) [SE/SE]; 164 83 Stockholm (SE).

(72) Inventor; and

(71) Applicant (for SC only): WANG, Zhancang [CN/CN]; No. 5 Lize East Street, Chaoyang District, Beijing 100102 (CN).

(74) Agent: ZHONGZI LAW OFFICE; 7F, New Era Building, 26 Pinganli Xidajie, Xicheng District, Beijing 100034 (CN).

(81) Designated States (unless otherwise indicated, for every kind of national protection available): AE, AG, AL, AM, AO, AT, AU, AZ, BA, BB, BG, BH, BN, BR, BW, BY, BZ,

CA, CH, CL, CN, CO, CR, CU, CZ, DE, DJ, DK, DM, DO, DZ, EC, EE, EG, ES, FI, GB, GD, GE, GH, GM, GT, HN, HR, HU, ID, IL, IN, IR, IS, JO, JP, KE, KG, KH, KN, KP, KR, KW, KZ, LA, LC, LK, LR, LS, LU, LY, MA, MD, ME, MG, MK, MN, MW, MX, MY, MZ, NA, NG, NI, NO, NZ, OM, PA, PE, PG, PH, PL, PT, QA, RO, RS, RU, RW, SA, SC, SD, SE, SG, SK, SL, SM, ST, SV, SY, TH, TJ, TM, TN, TR, TT, TZ, UA, UG, US, UZ, VC, VN, ZA, ZM, ZW.

(84) Designated States (unless otherwise indicated, for every kind of regional protection available): ARIPO (BW, GH, GM, KE, LR, LS, MW, MZ, NA, RW, SD, SL, ST, SZ, TZ, UG, ZM, ZW), Eurasian (AM, AZ, BY, KG, KZ, RU, TJ, TM), European (AL, AT, BE, BG, CH, CY, CZ, DE, DK, EE, ES, FI, FR, GB, GR, HR, HU, IE, IS, IT, LT, LU, LV, MC, MK, MT, NL, NO, PL, PT, RO, RS, SE, SI, SK, SM, TR), OAPI (BF, BJ, CF, CG, CI, CM, GA, GN, GQ, GW, KM, ML, MR, NE, SN, TD, TG).

Published:

— with international search report (Art. 21(3))

(54) Title: BROADBAND HARMONIC LOAD MODULATION DOHERTY AMPLIFIERS

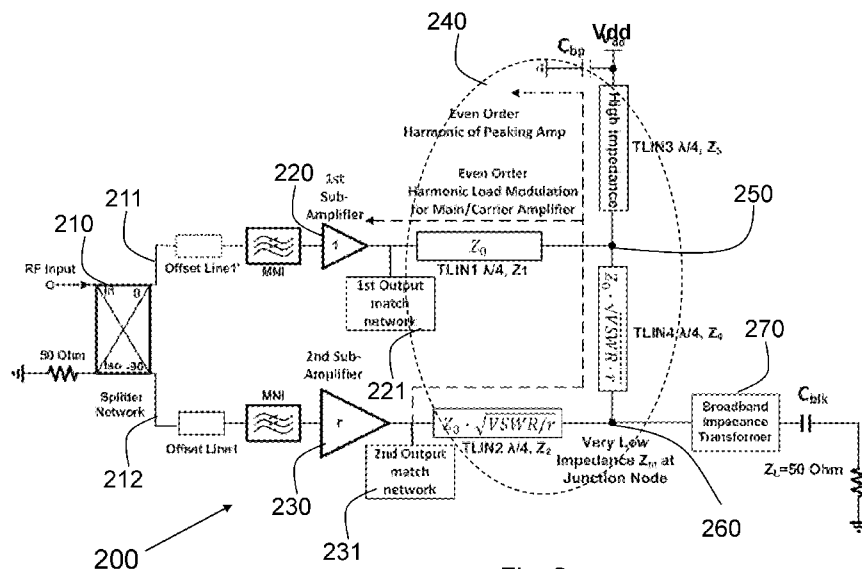

Fig. 2

(57) Abstract: A Doherty power amplifier arrangement comprises a splitter network, a first amplifier path comprising at least a first sub-amplifier and a first output matching network; a second amplifier path comprising at least a second sub-amplifier amplifier and a second output matching network. The Doherty power amplifier arrangement further comprises a load modulation network comprising four transmission lines. Each transmission line is a quarter wavelength line at a fundamental frequency of the input signal. Publ.



BROADBAND HARMONIC LOAD MODULATION DOHERTY AMPLIFIERS

TECHNICAL FIELD

Embodiments herein relate to power amplifiers. In particular, they relate to a Doherty
5 power amplifier with broadband harmonic load modulation, an electronic circuit and an
apparatus comprising the Doherty power amplifier.

BACKGROUND

Power amplifiers (PA) are ubiquitous in wireless communication equipment or device.
10 The efficiency of radio frequency (RF) PA is generally defined as a ratio between the desired
transmitted radio power and the total power from a supply, which is rather low in the future
wideband applications with traditional PA architectures. Consequently, extensive efforts are
made within the wireless communication industry for the means of enhancing efficiency. A
small improvement in PA efficiency can make substantial profit available in a wireless
15 communication system or terminal and cut the overall costs needed to operate the system or
terminal.

In cellular base stations of 4G and beyond, advanced digital modulation schemes are
used for high spectrum efficiency. The RF signal exhibits a large peak to average power ratio
(PAPR), which is amplified simultaneously in a PA. Therefore, the instantaneous transmit
20 power will vary extensively and fast. Traditional RF PA would suffer from rather low average
efficiency with high PAPR signal stimulus.

Although a classic Doherty PA meets the efficiency and linearity requirements, it is an
inherent narrow-band solution, because of the use of frequency limited quarter wave
transmission lines. Therefore, it may not satisfy the broadband requirements with emerging
25 wireless standards. A clear source of limited bandwidth in the Doherty PA is the impedance
inverter which connects the carrier and peaking amplifier together. It is essential in the
Doherty structure to transform the low common impedance $Z_0/2$ into a higher impedance
 $2*Z_0$ seen as the load of the carrier amplifier in the low power range. Also it assists to have a
proper active load modulation of higher impedance $2*Z_0$ into a lower impedance Z_0 in the
30 Doherty regime. However, this may be achieved at its center frequency. Any deviation from
the center frequency, the impedance inverter is no longer quarter wavelength. Then, the
purely resistive load seen by the carrier amplifier changes into a complex load, leading to a
non-optimal load modulation as the frequency deviation from the center frequency is
enlarged. Similar issues happen to a real-to-real impedance transformer as well. The

precision of matching the common load impedance into the final system load impedance may deteriorate owing to limited frequency response.

Harmonic termination has been widely used for compound semiconductor Doherty PAs. However, the complexity of the harmonic control circuitry may require great efforts for development and verification.

There are certain efforts to improve the efficiency performance of Doherty amplifiers by harmonic load modulation techniques, which do not require harmonic control circuitry and simplify the high efficiency PA development.

Figure 1 shows a Doherty amplifier 100 disclosed in Eccleston K. et. al., "A Compact Class-F/Class-C Doherty PA", Microwave and Optical Technology Letters, Vol. 53, No. 7, Jul, 2011, pp.1606-1610, and in Eccleston K. et.al., "Harmonic load modulation in Doherty amplifiers", Electronics Letters, 2008, Vol. 44, No. 2, pp.128-129. As shown in Figure 1, the main/carrier amplifier, denoted as Main FET, was originally class-B mode. However, after the harmonic load modulation effect by the peaking amplifier, Peaking FET, the main amplifier would behave like a class-F mode amplifier, in which the drain bias supplies are connected to the corresponding device drain terminals through the short-circuited quarter-wavelength transmission lines, Doherty line, providing inherent even-harmonic suppression. In this case, the drain current of the class-B biased main FET contains the direct current (DC), fundamental-frequency, and even-harmonic components. On the other hand, the drain current of the class-C biased peaking FET is purely sinusoidal ideally, since its odd-harmonic components are shunted by the short-circuited bias feed quarter wave line connected to the main FET, thus resulting in no harmonics appearing at the peaking FET output. The most advantage of it is that the odd harmonics of the class-C biased peaking FET flow into the main amplifier to achieve a class-F mode operation through a waveform shaping process without individual harmonic termination circuits. Such a scheme takes full advantage of a Doherty structure to incorporate harmonic terminations actively. Therefore, besides increased efficiency, this approach leads to a simplified and compact circuit.

However, the above prior art solution has limited operational bandwidth for broadband applications. The odd harmonic contribution in harmonic termination to output power and power added efficiency is quite limited. Although class-F produced by harmonic load modulation effect in prior art can achieve high efficiency, the effect of output parasitics of the main/carrier FET reduces the quality of the odd-harmonic short-circuit termination at the peaking FET, resulting in power amplifier efficiency degradation.

SUMMARY

It is an object of embodiments herein to provide a power amplifier with improved performance in terms of bandwidth and efficiency.

5 According to one aspect of embodiments herein, the object is achieved by a Doherty power amplifier arrangement. The Doherty power amplifier arrangement comprises a splitter network configured to split an input signal into a first input signal and a second input signal.

The Doherty power amplifier arrangement further comprises a first amplifier path comprising at least a first sub-amplifier configured to amplify the first input signal and a first
10 output matching network.

The Doherty power amplifier arrangement further comprises a second amplifier path comprising at least a second sub-amplifier configured to amplify the second input signal and a second output matching network.

The Doherty power amplifier arrangement further comprises a load modulation network.
15 The load modulation network comprises a first transmission line coupled between the first output matching network and a first interconnection node. The load modulation network further comprises a second transmission line coupled between the second output matching network and a second interconnection node. The load modulation network further comprises a third transmission line coupled between the first interconnection node and a power supply,
20 and a fourth transmission line coupled between the first interconnection node and the second interconnection node. Each transmission line is a quarter wavelength line at a fundamental frequency of the input signal, and the second interconnection node is an output terminal of the power amplifier arrangement.

25 In other words, according to the embodiments herein, the load modulation network comprises four transmission lines to complete both fundamental and harmonic load modulation for the proposed Doherty power amplifier arrangement. Each transmission line is a quarter wave ($\lambda/4$) transmission line at the fundamental frequency. In comparison to prior art, the characteristic impedance of these four transmission lines are very low, e.g. 1~6 Ohm.
30 The transmission lines, i.e. the first, second and fourth transmission lines, coupling the output terminals, i.e. drains of the two sub-amplifiers, are the harmonic load modulation transmission lines. Their characteristic impedances may be set to have a special relationship and combined to realize an impedance conversion such that the output terminal of the power amplifier arrangement has characteristic impedance which is much lower than e.g. 50 Ω , and

the off-state impedance for the second sub-amplifier, i.e. the peaking amplifier, in the Doherty power amplifier is increased.

The transmission line coupling the output terminals of the two sub-amplifiers, i.e. the fourth transmission line, is the fundamental load modulation transmission line. The third
5 transmission line feeds the power supply to the drains of the first and second sub-amplifiers, via the first and second transmission lines respectively. Therefore, a half wavelength transmission line is formed which presents a short-circuit load for the first sub-amplifier at odd order harmonics. The second/peaking sub-amplifier, on the other hand, has a class-C bias, and its drain current contains both even and odd harmonics, as well as the fundamental
10 and DC component. The even order harmonics are shunted to ground via the second, fourth and third transmission lines, which is a $3 \cdot \lambda / 4$ transmission line. Hence, the second/peaking sub-amplifier is short-circuit terminated at all harmonics and this means that no harmonics appear at the amplifier arrangement output. The load modulation network completes an impedance transformation from the output terminals of the first and second amplifiers to
15 specific low impedance for fundamental load modulation at the junction node, i.e. the second interconnection node or the output terminal of the power amplifier arrangement. Then a broadband impedance transformer may be used to transform the low output impedance to typical load impedance, e.g. 50Ω .

20 Some advantages of the Doherty power amplifier arrangement according to the embodiments herein include:

It provides broadband fundamental and harmonic load modulation at the same time to boost efficiency without any traditional harmonic termination schemes by using very low impedance combination and singular broadband impedance transformer.

25 It highly uses the 2nd harmonic rather than the 3rd harmonic in prior art to take full advantage and more obvious efficiency enhancement. Usually, the even harmonics, especially the 2nd harmonic may contribute a lot for harmonic termination. However, it was shorted to ground in prior art.

It incorporates the broadband harmonic load modulation network and the output
30 matching networks together for a compact Doherty PA design.

The embodiments herein may be applied to even Doherty, uneven Doherty, symmetric Doherty, asymmetric Doherty, inverted Doherty and multistage Doherty power amplifiers.

Therefore, the embodiment herein provides a power amplifier arrangement with
35 improved performance on bandwidth and efficiency.

BRIEF DESCRIPTION OF THE DRAWINGS

Examples of embodiments herein are described in more detail with reference to attached drawings in which:

- 5 Figure 1 is a schematic block illustrating a Doherty power amplifier of prior art;
Figure 2 is a simplified schematic view of a Doherty power amplifier arrangement according to embodiments herein;
Figure 3 is a simplified schematic view illustrating an example implementation of a Doherty power amplifier arrangement according to embodiments herein;
10 Figure 4 is a block diagram illustrating an electronic circuit or apparatus in which embodiments herein may be implemented.

DETAILED DESCRIPTION

15 **Figure 2** shows a Doherty power amplifier arrangement **200** according to embodiments herein.

The Doherty power amplifier arrangement 200 comprises a splitter network **210**, e.g. a quadrature hybrid coupler, configured to split an input signal into a first input signal **211** and a second input signal **212** to provide signals with necessary phase.

20 The Doherty power amplifier arrangement 200 further comprises a first amplifier path comprising at least a first sub-amplifier **220**, i.e. a main/carrier amplifier, configured to amplify the first input signal 211 and a first output matching network **221**.

The Doherty power amplifier arrangement 200 further comprises a second amplifier path comprising at least a second sub-amplifier amplifier **230**, i.e. a peaking amplifier, configured to amplify the second input signal 212 and a second output matching network **231**.

25 The first output matching network 221 matches a predetermined output impedance of the first sub-amplifier transistor to the input impedance of a first transmission line **TLIN1**.

The second output matching network 231 matches a predetermined output impedance of the second sub-amplifier transistor to the input impedance of a second transmission line **TLIN2**.

30 **Offset line 1 and 1'** are used to adjust and compensate the phase difference between the first amplifier path and the second amplifier path so that the output power combination can be performed on proper phase base.

The input matching network **MNI** matches a predetermined input impedance of the sub-amplifier transistor to the output impedance of the splitter network 210.

The Doherty power amplifier arrangement 200 further comprises a load modulation network 240. The load modulation network 240 comprises a first transmission line TLIN1 coupled between the first output matching network 221 and a first interconnection node 250. The load modulation network 240 further comprises a second transmission line TLIN2 coupled between the second output matching network 231 and a second interconnection node 260. The load modulation network 240 further comprises a third transmission line TLIN3 coupled between the first interconnection node 250 and a power supply V_{dd} . The load modulation network 240 further comprises a fourth transmission line TLIN4 coupled between the first interconnection node 250 and the second interconnection node 260. Each transmission line is a quarter wavelength line at a fundamental frequency of the input signal. The second interconnection node 260 is an output terminal of the power amplifier arrangement 200.

Therefore the load modulation network 240 comprises four transmission lines to complete both fundamental and harmonic load modulation for the Doherty power amplifier arrangement 200. In comparison to prior art, the characteristic impedance of these four transmission lines are very low, e.g. 1~6 Ohm.

The transmission lines coupling the drains of two sub-amplifiers, i.e. the main/carrier amplifier and the peaking amplifier, are TLIN1, TLIN2 and TLIN4, which are the harmonic load modulation transmission lines. According to some embodiments, the first transmission line TLIN1 has a characteristic impedance of Z_0 , the second transmission line TLIN2 has a characteristic impedance of $Z_0 \cdot \sqrt{VSWR}/r$, the fourth transmission line TLIN4 has a characteristic impedance of $Z_0 \cdot \sqrt{VSWR} \cdot r$. The first, second and fourth transmission lines are combined to realize an impedance conversion such that the output terminal of the power amplifier arrangement 200 has a characteristic impedance of $Z_m = Z_0 \cdot r$, which is much lower than 50 Ω , and the off-state output impedance of the second sub-amplifier is increased with a ratio of $VSWR \cdot r$, wherein r is a power ratio of the second sub-amplifier to the first sub-amplifier, and $VSWR$ is mismatch Voltage Standing Wave Ratio ($VSWR$) which equals to $(r+1)$.

These three single section quarter wave lines are combined together to realize impedance conversion to Z_m , while reducing the impedance transformation ratio. This impedance conversion is targeting to accommodate the other impedance happening in the second/peaking path so that high off-state impedance may be obtained. They will result in a common node impedance of $Z_m = Z_0 \cdot r$ by being parallel with the peaking path. Therefore, the common node impedance of the present embodiments is the same as the load

impedance so that it can save a real-to-real impedance transformer in comparison to the prior arts.

In the second/peaking path, there is a special single section quarter wave line TLIN2 with characteristic impedance of $Z_0 \cdot \sqrt{\text{VSWR}/r}$. This is to enhance off-state impedance for the peaking sub-amplifier, because it converts a Z_0/r value into $\frac{Z_0}{r} \cdot (\text{VSWR} \cdot r)$, which indicates it is $(\text{VSWR} \cdot r)$ times higher than that value in prior arts. Since $\text{VSWR} > 2$ for asymmetric Doherty, it indicates at least two times higher than the off-state impedance value of the prior arts. The benefit of this conversion is that it reduces the first/carrier/main amplifier power leakage to peaking path due to higher off-state impedance. Hence, the actual efficiency of the first/carrier/main sub-amplifier is more approaching to the value in ideal case so that the first carrier/main sub-amplifier efficiency may be enhanced in practice. Furthermore, this kind of enhancement also facilitates broadband performance with a reduced impedance transformation ratio.

The third transmission line TLIN3, feeds the power supply V_{dd} to the drains of the main and peaking sub-amplifiers, via the first transmission line TLIN1 and the second transmission line TLIN2, respectively. The characteristic impedance of the third transmission line is typically high but otherwise arbitrary. The capacitor **Cbp** has negligible impedance at RF frequencies and either blocks DC or provides RF short-circuit termination for the third quarter wave transmission line TLIN3.

The drain current of the first sub-amplifier 220, i.e. the main/carrier amplifier, which is class-AB/-B biased, contains a direct current (DC) component, the fundamental and even order harmonics. Unlike the prior art, the power supply was connected at drain, the power supply is now fed through a short-circuit load quarter wave length TLIN3 with high impedance first, and then fed through output matching quarter wave line TLIN1 to the drain of the first/main/carrier amplifier 220. Therefore, a half wavelength ($\lambda/2$) transmission line TLIN3 + TLIN4 is formed which presents a short-circuit load for the first/main/carrier sub-amplifier 220 at odd order harmonics.

Therefore, the first and third transmission lines may form a half wavelength transmission line between an output terminal of the first sub-amplifier 220 and the power supply V_{dd} , such that a short-circuit load is presented at the output terminal of the first sub-amplifier 220 for odd order harmonics.

However, at the drain of the first/main/carrier sub-amplifier 220, the even order harmonic exhibits an open-circuit terminated due to the second and fourth transmission lines TLIN2 + TLIN4 half wavelength line. Then the first/main/carrier amplifier 220 would behave

like a class-F⁻¹ mode rather than a class-B mode. So the second and fourth transmission lines TLIN2, TLIN4 may form a half wavelength transmission line such that an open-circuit load is presented at the output terminal of the first sub-amplifier 220 for even order harmonics.

5 The second/peaking sub-amplifier 230, on the other hand, has a class-C bias, and its drain current contains both even and odd order harmonics, as well as the fundamental and DC component. Unlike the main/carrier amplifier, the odd order harmonics of the peaking amplifier cannot be shunted to ground by a $\lambda/2$ transmission line nearby but the even order harmonics are shunted to ground via TLIN2+TLIN4 +TLIN3, which is a $3\lambda/4$ transmission
10 line. Hence, the peaking amplifier 230 is short-circuit terminated at all harmonics and means that no harmonics appear at the power amplifier arrangement 200 output terminal 260.

 Therefore, the second, fourth and third transmission lines TLIN2, TLIN4, TLIN3 may form a three-quarter wavelength transmission line between an output terminal of the second sub-amplifier 230 and the power supply V_{dd} , such that a short-circuit load is presented at the
15 output terminal of the second sub-amplifier 230 for both even and odd order harmonics.

 The load modulation network 240 completes an impedance transformation from the output terminals of the first and second amplifiers 220, 230 to specific low impedance Z_m for fundamental load modulation at the junction node, i.e. the second interconnection node 260
20 or the output terminal of the power amplifier arrangement 200. The fundamental component of both sub-amplifiers will be sum up and fundamentally load modulated with the assist of the fourth transmission line TLIN4 as impedance inverter in a classic Doherty PA.

 Then a broadband impedance transformer may be used to transform the low output impedance to typical load impedance, e.g. 50 Ω . The broadband impedance transformer may
25 be placed after the Doherty PA summing node, which is not limited to use the same technology of the output matching network of Doherty PA. Before the impedance transformer, there may be an offset line with the same input impedance of the broadband impedance transformer. The function of it is to place a transmission line of electrical length θ in series with the broadband impedance transformer. This tuning may be used to compensate for the
30 inability to accurately predict the optimum θ offset value, and to effectively adjust it as required to compensate for changes in other circuit characteristics.

 Therefore, according to some embodiments, the power amplifier arrangement 200 further comprises an impedance transformer **270** to transfer the lower output impedance of the power amplifier arrangement 200 to 50 Ω . C_{blk} is the AC-coupling capacitor to provide DC
35 isolation to the final load.

At the fundamental frequency, the first/main/carrier amplifier and second/peaking amplifier interact in a Doherty way so that the first, second and fourth transmission lines impedance Z_1 and Z_2, Z_4 , are set to a proper ratio of an intermediate load impedance Z_m at the second interconnection node, that is the input impedance of the broadband impedance transformer 270. All the odd order harmonics of the first/main sub-amplifier 220 are locally shunted to ground via the third transmission line TLIN3. Because the even order harmonics from the second/peaking sub-amplifier 230 flow through TLIN2, TLIN4 and TLIN3, the even order harmonic standing waves are established on TLIN1 at the drain of the first/main sub-amplifier 220. These even order harmonics “square” the main amplifier drain current waveform due to the kind of harmonic load modulation effect.

In practice, limited harmonic orders will be counted. Since the 2nd and the 3rd order harmonics are the strongest and most practical ones, they are considered in concept verification and comparison with the prior art.

Table 1 lists the comparison with the prior art features to show the key differentiations between the present embodiments and the prior art.

Table 1

	Prior art	Present embodiment
Class of main amplifier after harmonic load modulation	Class-F	Class-F ⁻¹
Even harmonic @ Drain of main amplifier	Short	Open
Odd harmonic @ Drain of Main amplifier	Open	Short
Even harmonic @ Final output	Short by $\lambda / 4$	Short by $3 \lambda / 4$
Odd Harmonic @ Final Output	Short by $\lambda / 2$	Short by $\lambda / 2$
Wavelength to Short Even Harmonic	$\lambda / 4$	$3 \lambda / 4$
Wavelength to Short Odd Harmonic	$\lambda / 2$	$\lambda / 2$
Use separated fundamental and harmonic load modulation schemes?	NO	YES
Use quarter wave impedance matching?	NO	YES

Figure 3 shows an example implementation of the Doherty power amplifier 200 with impedance parameters in low-power and high-power modes respectively, where $Z_0=1.25$ Ohm, $r=1.6$, $VSWR=2.6$, $Z_m=2$ Ohm and $Z_L=50$ Ohm. Z_0 is the characteristic impedance of

the first transmission line, r is the peaking to main power amplifiers power ration, for asymmetric Doherty PA, $r > 1$. VSWR denotes Mismatch Voltage Standing Wave Ratio which equals to $(r+1)$, $VSWR \geq 2$. Z_L is the final output load impedance which is typically 50 Ohm. Z_m is the intermediate load impedance at junction node which is typically very low value e.g. 1~6 Ohm.

It should be noted here that Z_m has a particular relationship to Z_0 and r values with $Z_m = Z_0 * r = 1.25 * 1.6 = 2$.

In Figure 3, Z_{mod} and Z_{opt} denote the output impedance seen from the drain of the main sub-amplifier in low-power and high-power modes, respectively.

Z_{off} and Z'_{opt} denote the output impedance seen from the drain of the peaking sub-amplifier in low-power and high-power modes, respectively.

Assume Z_{off} approaches to zero impedance, which indicates the scenario that is suitable to use inverted Doherty PA topology.

To summarize, according to embodiments herein, some advantages of the Doherty power amplifier 100 include:

It provides broadband fundamental and harmonic load modulation at the same time to boost efficiency without any traditional harmonic termination schemes by using very low impedance combination and singular broadband impedance transformer. The load modulation network is used to enhance the off-state impedance for the peaking amplifier by special arrangement for impedance transformers. The impedance relations between the transmission lines in the load modulation network guarantee much easier matching the output impedance seen from the drain of carrier/main amplifier in low-power and high-power modes, i.e. Z_{mod} and Z_{opt} , and the output impedance seen from the drain of the peaking amplifier in low power and high-power modes, i.e. Z_{off} and Z'_{opt} , simultaneously in a single output matching network.

It highly uses the 2nd harmonic rather than the 3rd harmonic in prior art to take full advantage and more obvious efficiency enhancement. Usually, the even harmonics, especially the 2nd harmonic may contribute a lot for harmonic termination. However, it was shorted to ground in prior art. It would be a kind of waste of resource.

It incorporates the broadband harmonic load modulation network and the output matching networks together for a compact Doherty PA design. By using this topology, the offset line after the main/carrier amplifier may be completely removed so that compact design can be realized. Also the impedance inverter can be partially absorbed by the output matching network of the peaking amplifier which can minimize the size of the Doherty amplifier implementation.

The embodiments herein may be applied to even Doherty, uneven Doherty, symmetric Doherty, asymmetric Doherty, inverted Doherty and multistage Doherty power amplifiers.

The Doherty power amplifier arrangement 200 according to the embodiments herein
5 may be employed in various electronic circuits or apparatuses. **Figure 4** shows a block
diagram for an electronic circuit or apparatus **400**. The electronic circuit or apparatus 400
comprises a Doherty power amplifier arrangement 200. The electronic circuit or apparatus
400 may be a transmitter or a transceiver in a cellular communications system/network. The
10 electronic apparatus 400 may comprise other units, where a memory **420**, a processing unit
430 are shown. The electronic apparatus 400 may be a user equipment or a mobile device, a
wireless communication device, a radio base station for a cellular communication system.

Those skilled in the art will understand that the Doherty power amplifier arrangement
200 according to embodiments herein may be implemented by any semiconductor
15 technology.

When using the word "comprise" or "comprising" it shall be interpreted as non-limiting,
i.e. meaning "consist at least of".

The embodiments herein are not limited to the above described embodiments. Various
20 alternatives, modifications and equivalents may be used. Therefore, the above embodiments
should not be taken as limiting the scope of the embodiments herein, which is defined by the
appended claims.

CLAIMS

1. A Doherty power amplifier arrangement (200) comprising:
- 5 a splitter network (210) configured to split an input signal into a first input signal (211) and a second input signal (212);
- a first amplifier path comprising at least a first sub-amplifier (220) configured to amplify the first input signal and a first output matching network (221);
- a second amplifier path comprising at least a second sub-amplifier (230) configured to amplify the second input signal and a second output matching network (231); and
- 10 a load modulation network (240); wherein the load modulation network (240) comprises:
- a first transmission line (TLIN1) coupled between the first output matching network (221) and a first interconnection node (250);
- 15 a second transmission line (TLIN2) coupled between the second output matching network (231) and a second interconnection node (260);
- a third transmission line (TLIN3) coupled between the first interconnection node (250) and a power supply (V_{dd}); and
- a fourth transmission line (TLIN4) coupled between the first interconnection node (250) and the second interconnection node (260);
- 20 wherein each transmission line is a quarter wavelength line at a fundamental frequency of the input signal, and the second interconnection node (260) is an output terminal of the power amplifier arrangement (200).
- 25 2. The power amplifier arrangement (200) according to claim 1, wherein the first transmission line (TLIN1) has a characteristic impedance of Z_0 , the second transmission line (TLIN2) has a characteristic impedance of $Z_0 \cdot \sqrt{VSWR/r}$, the fourth transmission line (TLIN4) has a characteristic impedance of $Z_0 \cdot \sqrt{VSWR \cdot r}$, and wherein the first, second and fourth transmission lines are combined to realize an
- 30 impedance conversion such that the output terminal of the power amplifier arrangement has a characteristic impedance of $Z_m = Z_0 \cdot r$, which is much lower than 50Ω , and the off-state output impedance of the second sub-amplifier is increased with a ratio of $VSWR \cdot r$, wherein r is a power ratio of the second sub-amplifier to the first sub-amplifier, and VSWR is mismatch Voltage Standing Wave Ratio (VSWR) which
- 35 equals to $(r+1)$.

3. The power amplifier arrangement (200) according to any one of claims 2-3 further comprising an impedance transformer to transfer the lower output impedance of the power amplifier arrangement to 50 Ω .
- 5
4. The power amplifier arrangement according to any one of claims 1-3, wherein the first and third transmission lines form a half wavelength transmission line between an output terminal of the first sub-amplifier and the power supply, such that a short-circuit load is presented at the output terminal of the first sub-amplifier for odd order
- 10 harmonics, and the second and fourth transmission lines form a half wavelength transmission line such that an open-circuit load is presented at the output terminal of the first sub-amplifier for even order harmonics.
5. The power amplifier arrangement according to any one of claims 1-4, wherein the
- 15 second, fourth and third transmission lines form a three quarter wavelength transmission line between an output terminal of the second sub-amplifier and the power supply, such that a short-circuit load is presented at the output terminal of the second sub-amplifier for both even and odd order harmonics.
- 20 6. An electronic circuit comprising a power amplifier arrangement according to any one of claims 1-5.
7. An electronic apparatus comprising a power amplifier arrangement according to any one of claims 1-5.
- 25 8. The electronic apparatus according to claim 7, wherein the electronic apparatus is a wireless communication device for a cellular communication system.
9. The electronic apparatus according to claim 7, wherein the electronic apparatus is a
- 30 radio base station for a cellular communication system.

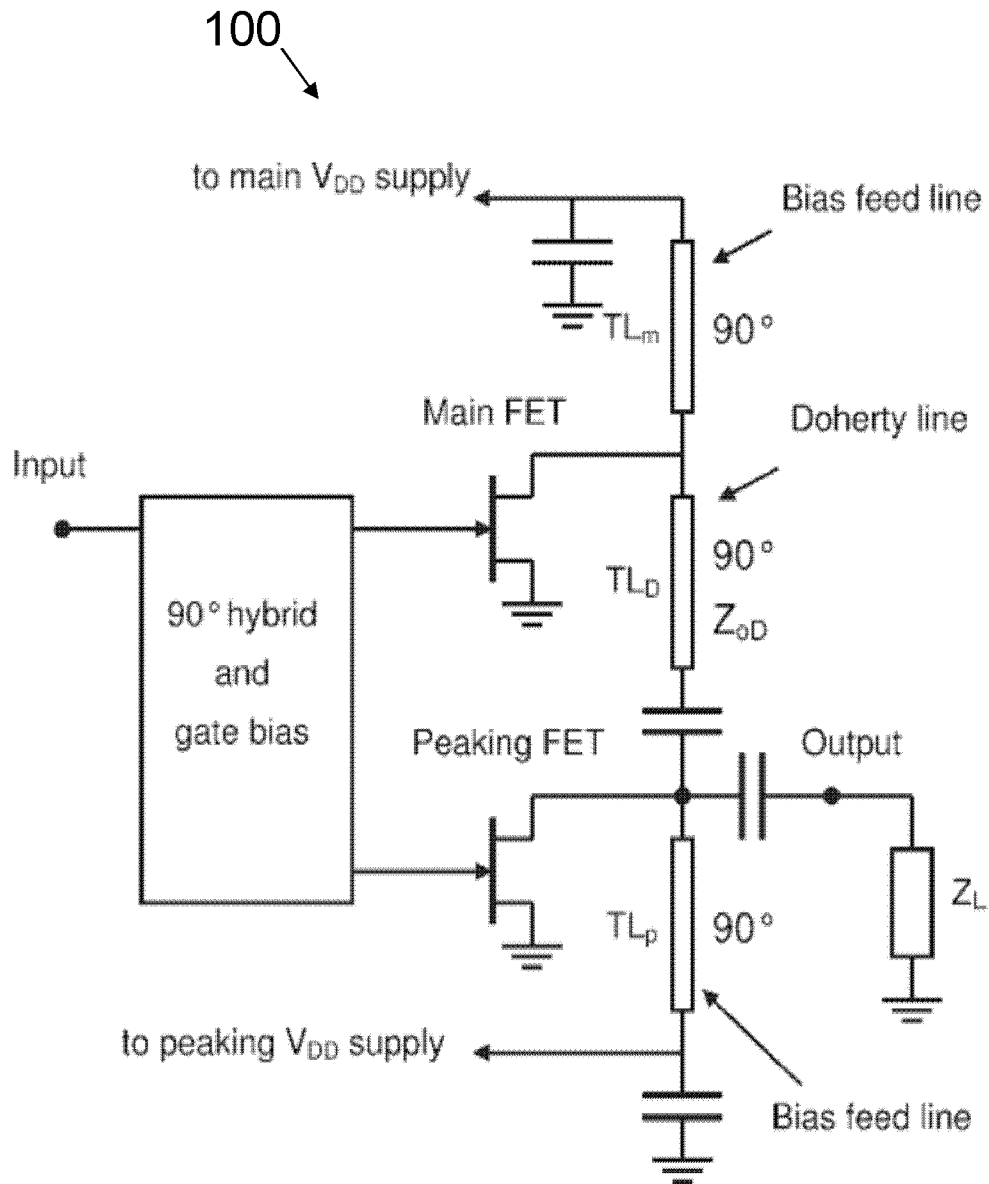

Fig. 1

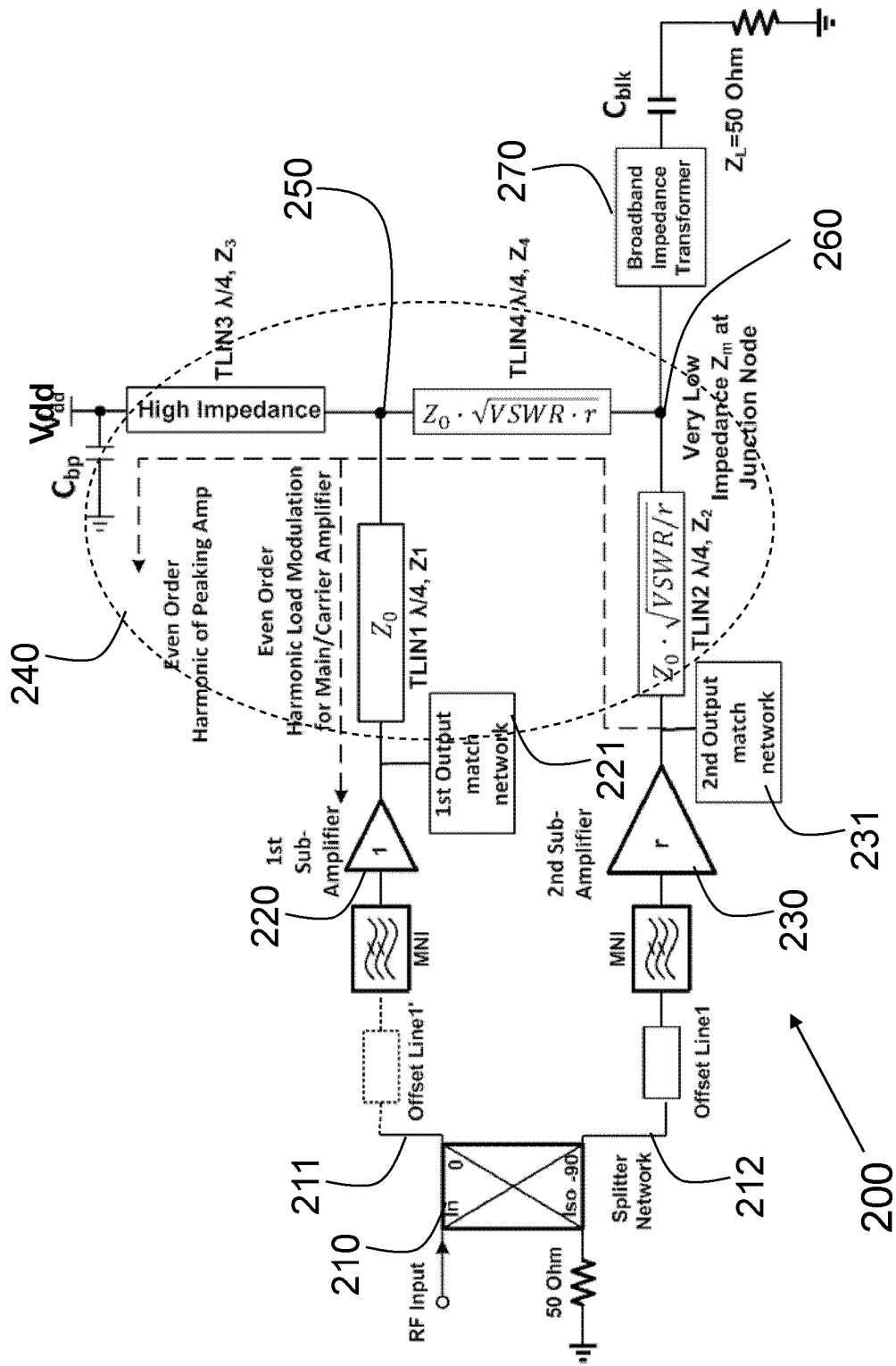

Fig. 2

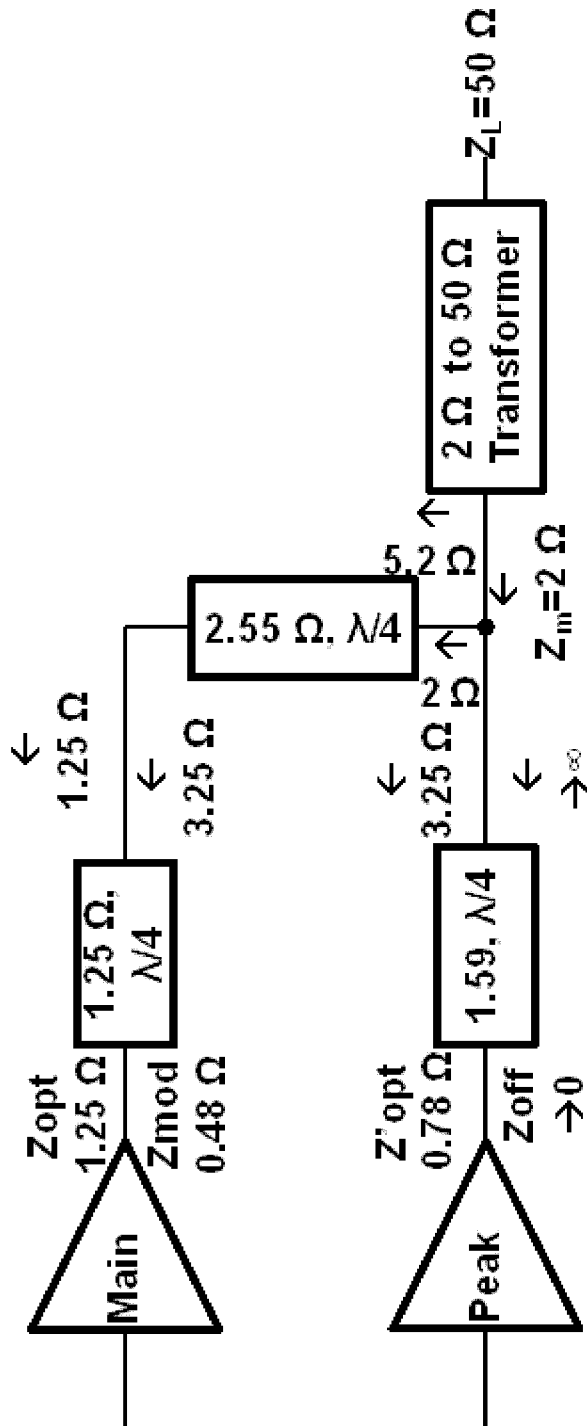

Fig. 3

4/4

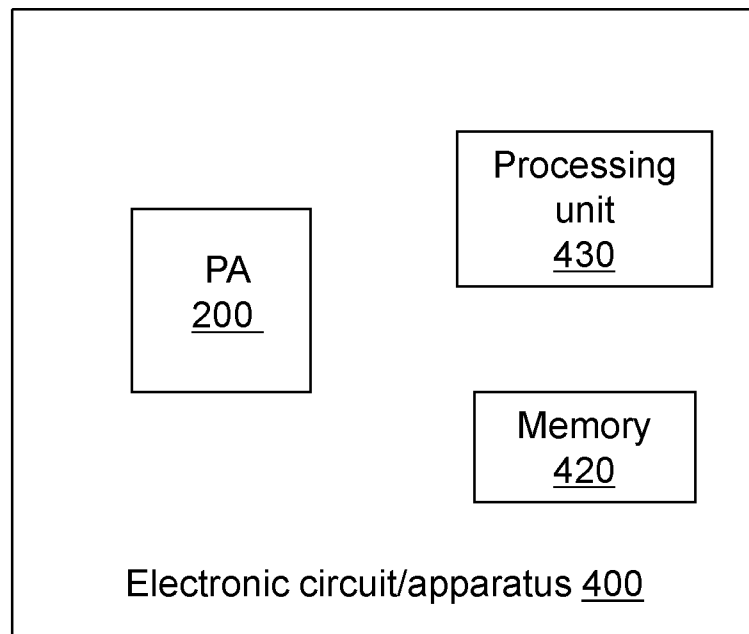

Fig. 4

INTERNATIONAL SEARCH REPORT

International application No.

PCT/CN2018/076225

A. CLASSIFICATION OF SUBJECT MATTER		
H03F 1/07(2006.01)i		
According to International Patent Classification (IPC) or to both national classification and IPC		
B. FIELDS SEARCHED		
Minimum documentation searched (classification system followed by classification symbols)		
H03F		
Documentation searched other than minimum documentation to the extent that such documents are included in the fields searched		
Electronic data base consulted during the international search (name of data base and, where practicable, search terms used)		
CNPAT,WPI,EPODOC,IEEE,CNKI,GOOGLE: Doherty,power,amplifier,DPA,load,modulation,network,transformer, impedance		
C. DOCUMENTS CONSIDERED TO BE RELEVANT		
Category*	Citation of document, with indication, where appropriate, of the relevant passages	Relevant to claim No.
X	EP 3046253 A1 (NEC CORPORATION) 20 July 2016 (2016-07-20) description, paragraphs [0012]-[0021], figure 1	1-9
X	US 2011175677 A1 (POSTECH ACADEMY-INDUSTRY FOUNDATION) 21 July 2011 (2011-07-21) description, paragraphs [0040]-[0051], figure 3	1-9
X	CN 107425814 A (HANGZHOU DIANZI UNIVERSITY) 01 December 2017 (2017-12-01) description, paragraphs [0053]-[0055], figure 5	1-9
A	EP 3043469 A1 (KABUSHIKI KAISHA TOSHIBA) 13 July 2016 (2016-07-13) the whole document	1-9
A	CN 103457541 A (UNIVERSITY OF ELECTRONIC SCIENCE AND TECHNOLOGY OF CHINA) 18 December 2013 (2013-12-18) the whole document	1-9
<input type="checkbox"/> Further documents are listed in the continuation of Box C. <input checked="" type="checkbox"/> See patent family annex.		
* Special categories of cited documents: "A" document defining the general state of the art which is not considered to be of particular relevance "E" earlier application or patent but published on or after the international filing date "L" document which may throw doubts on priority claim(s) or which is cited to establish the publication date of another citation or other special reason (as specified) "O" document referring to an oral disclosure, use, exhibition or other means "P" document published prior to the international filing date but later than the priority date claimed "T" later document published after the international filing date or priority date and not in conflict with the application but cited to understand the principle or theory underlying the invention "X" document of particular relevance; the claimed invention cannot be considered novel or cannot be considered to involve an inventive step when the document is taken alone "Y" document of particular relevance; the claimed invention cannot be considered to involve an inventive step when the document is combined with one or more other such documents, such combination being obvious to a person skilled in the art "&" document member of the same patent family		
Date of the actual completion of the international search		Date of mailing of the international search report
31 October 2018		12 November 2018
Name and mailing address of the ISA/CN		Authorized officer
STATE INTELLECTUAL PROPERTY OFFICE OF THE P.R.CHINA 6, Xitucheng Rd., Jimen Bridge, Haidian District, Beijing 100088 China		GAO,Dandan
Facsimile No. (86-10)62019451		Telephone No. 86-(10)-53961301

INTERNATIONAL SEARCH REPORT
Information on patent family members

International application No.

PCT/CN2018/076225

Patent document cited in search report			Publication date (day/month/year)	Patent family member(s)			Publication date (day/month/year)
EP	3046253	A1	20 July 2016	US	2016190997	A1	30 June 2016
				WO	2015037034	A1	19 March 2015
US	2011175677	A1	21 July 2011	KR	20110085340	A	27 July 2011
				JP	2011151787	A	04 August 2011
CN	107425814	A	01 December 2017	None			
EP	3043469	A1	13 July 2016	US	2016204747	A1	14 July 2016
				JP	2016129311	A	14 July 2016
CN	103457541	A	18 December 2013	None			