

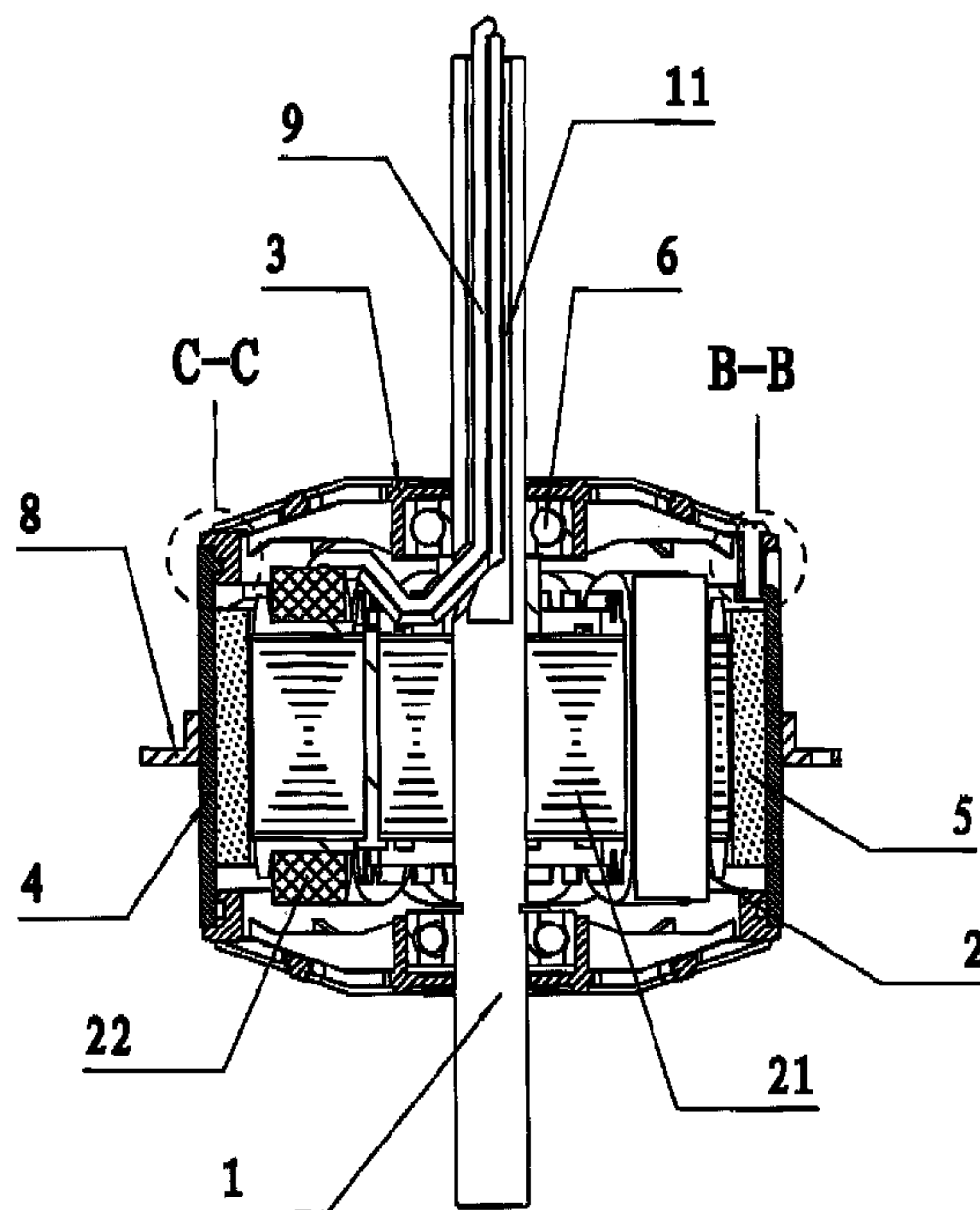

(22) Date de dépôt/Filing Date: 2013/09/24
 (41) Mise à la disp. pub./Open to Public Insp.: 2014/04/30
 (45) Date de délivrance/Issue Date: 2017/08/15
 (30) Priorité/Priority: 2012/10/31 (CN201220569541.2)

(51) Cl.Int./Int.Cl. *H02K 5/04* (2006.01),
H02K 1/27 (2006.01), *H02K 5/16* (2006.01)
 (72) Inventeurs/Inventors:
LU, CHUPING, CN;
TANG, SONGFA, CN;
ZENG, CHONGSHENG, CN
 (73) Propriétaire/Owner:
ZHONGSHAN BROAD-OCEAN MOTOR CO., LTD., CN
 (74) Agent: H&M PATENT AND TRADEMARK AGENTS

(54) Titre : MOTEUR A COURANT CONTINU, SANS BALAIS, AVEC ROTOR EXTERNE
 (54) Title: DC BRUSHLESS MOTOR WITH EXTERNAL ROTOR



(57) Abrégé/Abstract:

A DC brushless motor having an external rotor, the motor including: a shaft, a stator assembly, an end cover, a housing, and a plurality of permanent magnets. The end cover includes a bearing. The housing includes: an inner wall, and an end. The shaft is connected with the stator assembly. The stator assembly is arranged inside the housing. The permanent magnets are positioned outside the stator assembly on the inner wall of the housing. The end cover is disposed on the end of the housing. The shaft is disposed on the bearing of the end cover.

ABSTRACT

A DC brushless motor having an external rotor, the motor including: a shaft, a stator assembly, an end cover, a housing, and a plurality of permanent magnets. The end cover includes a bearing. The housing includes: an inner wall, and an end. The shaft is connected with the stator assembly. The stator assembly is arranged inside the housing. The permanent magnets are positioned outside the stator assembly on the inner wall of the housing. The end cover is disposed on the end of the housing. The shaft is disposed on the bearing of the end cover.

DC BRUSHLESS MOTOR WITH EXTERNAL ROTOR

FIELD OF THE INVENTION

[0001] The invention relates to a DC brushless motor having an external rotor.

BACKGROUND OF THE INVENTION

[0002] For a typical DC brushless motor having an external rotor, one end of a shaft is connected with a rotor body; the other end of the shaft is connected with a flange, so that the shaft rotates along with the rotor and drives the flange to rotate. However, the rotor is disposed on one side; a force is unevenly distributed on the motor. After the flange and the external wind wheel are installed and connected, the whole system runs unsteadily which affects air speed of a wind wheel.

SUMMARY OF THE INVENTION

[0003] In view of the above-described problems, it is one objective of the invention to provide a DC brushless motor having an external rotor that has a simple structure, uneven force distribution, and a steady operation of a system.

[0004] To achieve the above objective, in accordance with one embodiment of the invention, there is provided a DC brushless motor having an external rotor, comprising: a shaft; a stator assembly; an end cover, the end cover comprising a bearing; a housing, the housing comprising: an end, and an inner wall; and a plurality of permanent magnets. The shaft is connected with the stator assembly; the stator assembly is arranged inside the housing. The permanent magnets are positioned outside the stator assembly on the inner wall of the housing. The end cover is disposed on the end of the housing. The shaft is

disposed on the bearing of the end cover.

[0005] A plurality of mounting bosses is disposed on the end of the housing above end surfaces of the permanent magnets. Each mounting boss comprises a threaded hole. The end cover comprises a through hole. A screw passes through the through hole of the end cover and is screwed into the threaded hole for fixing the end cover on the housing.

[0006] A gap is arranged in an axial direction on a side wall of the end cover outside the through hole. A recess in a ring shape is arranged on the side wall of the end cover. The gap is in communication with the recess. An end of the inner wall of the housing is convex to form a fixture block. The fixture block passes through the gap and is inserted into the recess.

[0007] An end surface of the end cover is provided with a plurality of clay recesses for correcting a dynamic balance.

[0008] A mounting bracket is arranged outside the housing.

[0009] The stator assembly comprises: a stator core, and a winding. The winding is wound on the stator core. One end of an external lead is connected with one end of the winding; and the other end of the external lead passes through a shaft hole of the shaft.

[0010] The permanent magnets are stuck to the inner wall of the housing by glue.

[0011] Advantages of the invention are summarized as follows:

[0012] 1) The DC brushless motor having an external rotor of the invention comprises: the shaft, the stator assembly, the end cover, the housing, and a plurality of permanent magnets. The shaft is connected with the stator assembly. The stator assembly is arranged inside the housing. The permanent magnets are positioned outside the stator assembly on the inner wall of the housing. The end cover is disposed on the end of the housing. The shaft is disposed on a bearing of the end cover. The invention has a simple structure, uneven force distribution, and

a steady operation of a system.

[0013] 2) A plurality of mounting bosses is disposed on the end of the housing above end surfaces of the permanent magnets. The threaded holes are disposed on the mounting boss. The screw passes through a through hole of the end cover and is screwed into the threaded hole for fixing the end cover on the housing. The structure is reasonably designed, and the connection is firm.

[0014] 3) The gaps are arranged in the axial direction on a side wall of the end cover outside the through hole. The recess in a ring shape is arranged on the side wall of the end cover. The gaps are in communication with the recess. The end of the inner wall of the housing is convex to form the fixture block, and the fixture block passes through the gap and is inserted into the recess. Thus, the end cover is fixed in the axial direction.

[0015] 4) An end surface of the end cover is provided with a plurality of clay recesses for correcting a dynamic balance. Clay used to correct the dynamic balance is disposed on the clay recesses.

[0016] 5) The mounting bracket is arranged outside the housing; the mounting bracket is connected having an external wind wheel, which has an even force distribution and firm connection.

BRIEF DESCRIPTION OF THE DRAWINGS

[0017] FIG. 1 is a stereogram of a DC brushless motor having an external rotor in accordance with one embodiment of the invention;

[0018] FIG. 2 is an exploded view of a DC brushless motor having an external rotor in accordance with one embodiment of the invention;

[0019] FIG. 3 is a structure diagram of a DC brushless motor having an external rotor in accordance with one embodiment of the invention;

[0020] FIG. 4 is a cross sectional view of FIG. 3 taken from line A-A;

[0021] FIG. 5 is an enlarged view of part B-B of FIG. 4;

[0022] FIG. 6 is an enlarged view of part C-C of FIG. 4; and

[0023] FIG. 7 is a stereogram of an end cover in accordance with one embodiment of the invention.

DETAILED DESCRIPTION OF THE EMBODIMENTS

[0024] For further illustrating the invention, experiments detailing a DC brushless motor having an external rotor are described below. It should be noted that the following examples are intended to describe and not to limit the invention.

Example 1

[0025] As shown in FIGS. 1-7, a DC brushless motor having an external rotor comprises: a shaft 1, a stator assembly 2, an end cover 3, a housing 4, and a plurality of permanent magnets 5. The shaft 1 is connected with the stator assembly 2. The stator assembly 2 is arranged inside the housing 4. The permanent magnets 5 are positioned outside the stator assembly 2 on an inner wall of the housing 4. The end cover 3 is disposed on an end of the housing 4. The shaft 1 is disposed on a bearing 6 of the end cover 3.

Example 2

[0026] On the basis of Example 1, the following technical features are added: a plurality of mounting bosses 41 is disposed on the end of the housing 4 above end surfaces of the

permanent magnets 5. A threaded hole 410 is disposed on each mounting boss 41. A screw 7 passes through a through hole 31 of the end cover 3 and is screwed into the threaded hole 410 for fixing the end cover 3 on the housing 4.

Example 3

[0027] On the basis of Example 2, the following technical features are added: a gap 32 is arranged in an axial direction on a side wall of the end cover 3 outside the through hole 31. A recess 33 in a ring shape is arranged on the side wall of the end cover 3. The gap 32 is in communication with the recess 33. An end of the inner wall of the housing 4 is convex to form a fixture block 42, and the fixture block 42 passes through the gap 32 and is inserted into the recess 33.

Example 4

[0028] On the basis of Example 1, 2, or 3, the following technical feature is added: an end surface of the end cover 3 is provided with a plurality of clay recesses 34 for correcting a dynamic balance.

Example 5

[0029] On the basis of Example 1, the following technical feature is added: a mounting bracket 8 is arranged outside the housing 4.

Example 6

[0030] On the basis of Example 1, the following technical features are added: the stator assembly 2 comprises: a stator core 21, and a winding 22. The winding 22 is wound on

the stator core 21. One end of an external lead 9 is connected with one end of the winding 22; the other end of the external lead 9 passes through a shaft hole 11 of the shaft 1.

Example 7

[0031] On the basis of Example 1, the following technical feature is added: the permanent magnets 5 are stuck to the inner wall of the housing 4 by glue.

[0032] The motor comprises: the shaft 1, the stator assembly 2, the end cover 3, the housing 4, and a plurality of permanent magnets 5. The shaft 1 is connected with the stator assembly 2. The stator assembly 2 is arranged inside the housing 4. A plurality of permanent magnets 5 is positioned outside the stator assembly 2 on the inner wall of the housing 4. The axial gap 23 and the annular recess 33 are arranged on the side wall of the end cover. The gap 32 is in communication with the recess 33. The fixture block 42 is arranged on the end of the inner wall of the housing 4. The fixture block 42 passes through the gap 32 of the end cover 3 and is inserted into the recess 33 to allow the through hole 31 of the end cover 3 to align with the threaded hole 410 of the mounting boss 41 of the housing 4, so that the end cover 3 is fixed on the housing 4 by inserting the screw 7 into the through hole 31 and the threaded hole 410.

[0033] While particular embodiments of the invention have been shown and described, it will be obvious to those skilled in the art that changes and modifications may be made without departing from the invention in its broader aspects, and therefore, the aim in the appended claims is to cover all such changes and modifications as fall within the true spirit and scope of the invention.

CLAIMS

1. A DC brushless motor, comprising:

- a) a shaft (1);
- b) a stator assembly (2);
- c) an end cover (3), the end cover (3) comprising a bearing (6);
- d) a housing (4), the housing (4) comprising an inner wall and an end, the inner wall of the housing (4) comprising a fixture block (42); and
- e) a plurality of permanent magnets (5);

wherein:

the shaft (1) is connected with the stator assembly (2);

the stator assembly (2) is arranged inside the housing (4);

the plurality of permanent magnets (5) is positioned outside the stator assembly (2) on the inner wall of the housing (4);

the end cover (3) is disposed on the end of the housing (4);

the shaft (1) is disposed on the bearing (6) of the end cover (3);

a plurality of mounting bosses (41) is disposed on the end of the housing (4) above end surfaces of the permanent magnets (5);

each of the plurality of mounting bosses (41) comprises a threaded hole (410);

the end cover (3) comprises a plurality of through holes (31);

a screw (7) passes through each of the plurality of through holes (31) of the end cover (3) and is screwed into the threaded hole (410) for fixing the end cover (3) on the housing (4);

a gap (32) is arranged axially on a side wall of the end cover (3);

a groove (33) in a ring shape is arranged circumferentially on an outside wall of the end cover (3);

the gap (32) is in communication with the groove (33); and

the fixture block (42) is disposed inside the groove (33).

2. The motor of claim 1, wherein an end surface of the end cover (3) is provided with a plurality of clay recesses (34) for correcting a dynamic balance.
3. The motor of claim 1, wherein a mounting bracket (8) is arranged outside the housing (4).
4. The motor of claim 1, wherein
 - the stator assembly (2) comprises a stator core (21) and a winding (22);
 - the winding (22) is wound on the stator core (21);
 - one end of an external lead (9) is connected with one end of the winding (22); and
 - the other end of the external lead (9) passes through a shaft hole (11) of the shaft (1).
5. The motor of claim 1, wherein the permanent magnets (5) are stuck to the inner wall of the housing (4) by glue.
6. The motor of claim 1, wherein the screw (7) is arranged parallel to the shaft (1).
7. The motor of claim 1, wherein the fixture block (42) is disposed in the proximity to one of the plurality of mounting bosses (41).

8. The motor of claim 1, wherein during assembling of the motor, the fixture block (42) first passes through the gap (32), then moves towards the groove (33), and finally is disposed inside the groove (33).

1/7

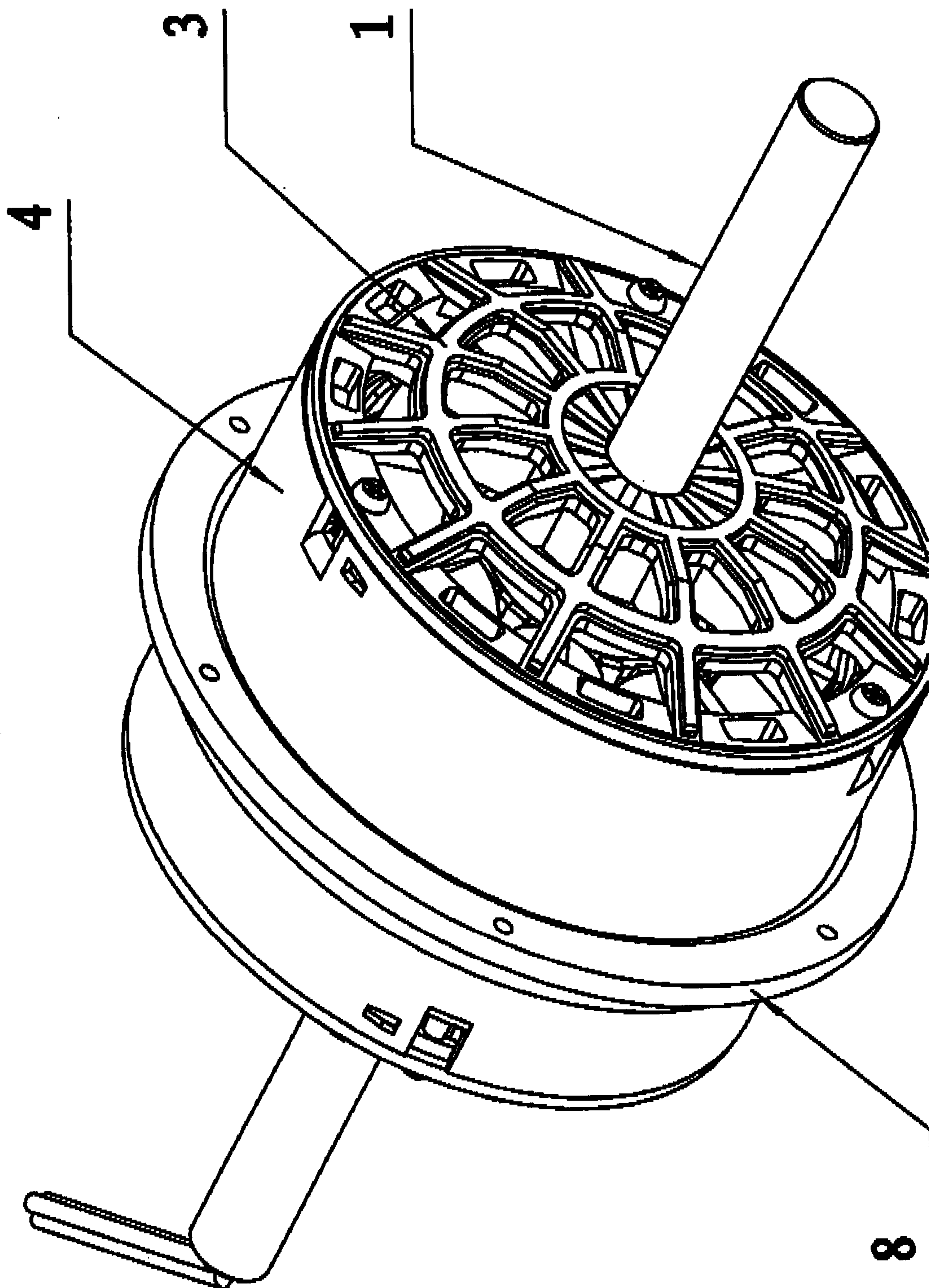

FIG. 1

2/7

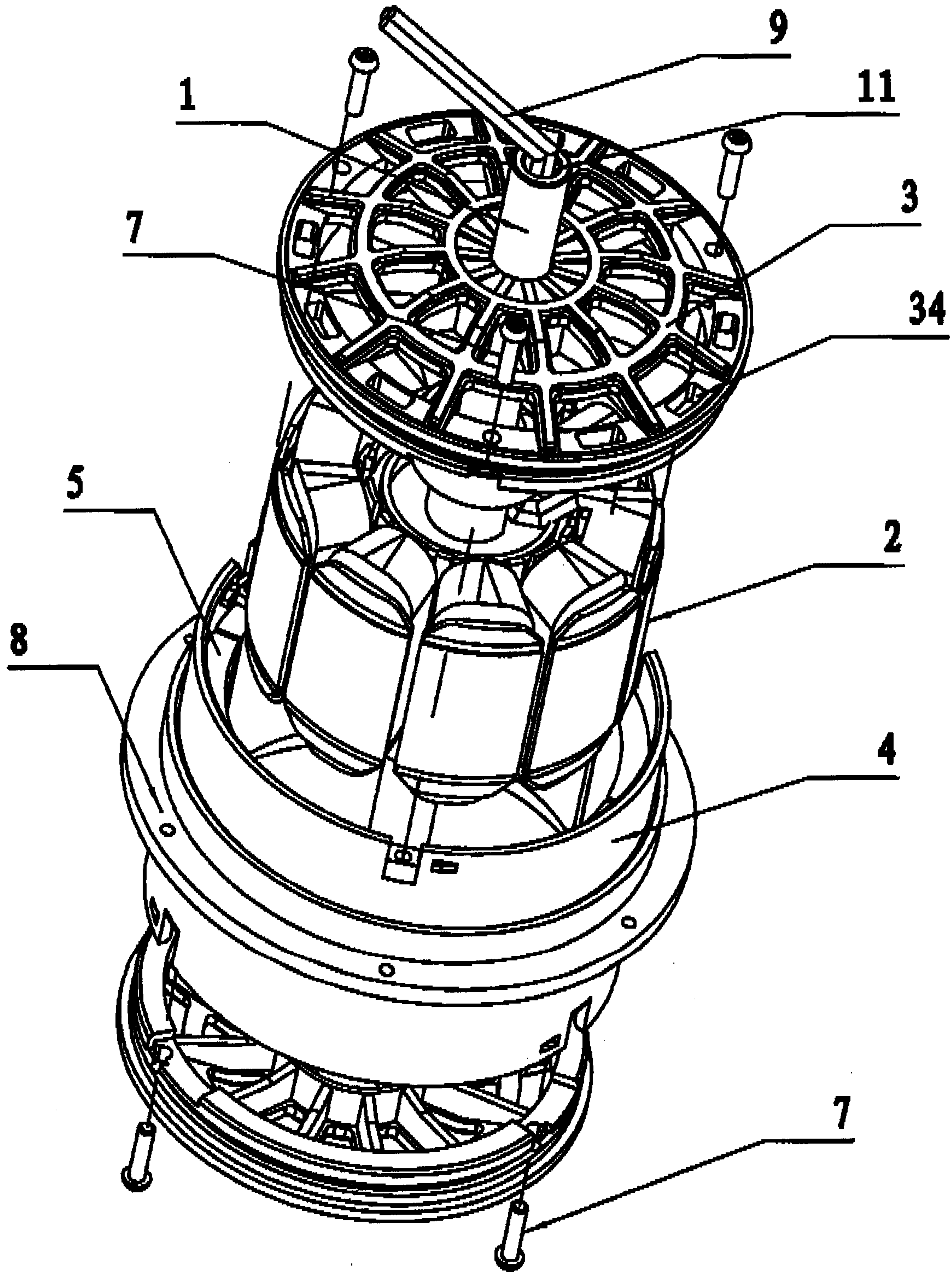

FIG. 2

3/7

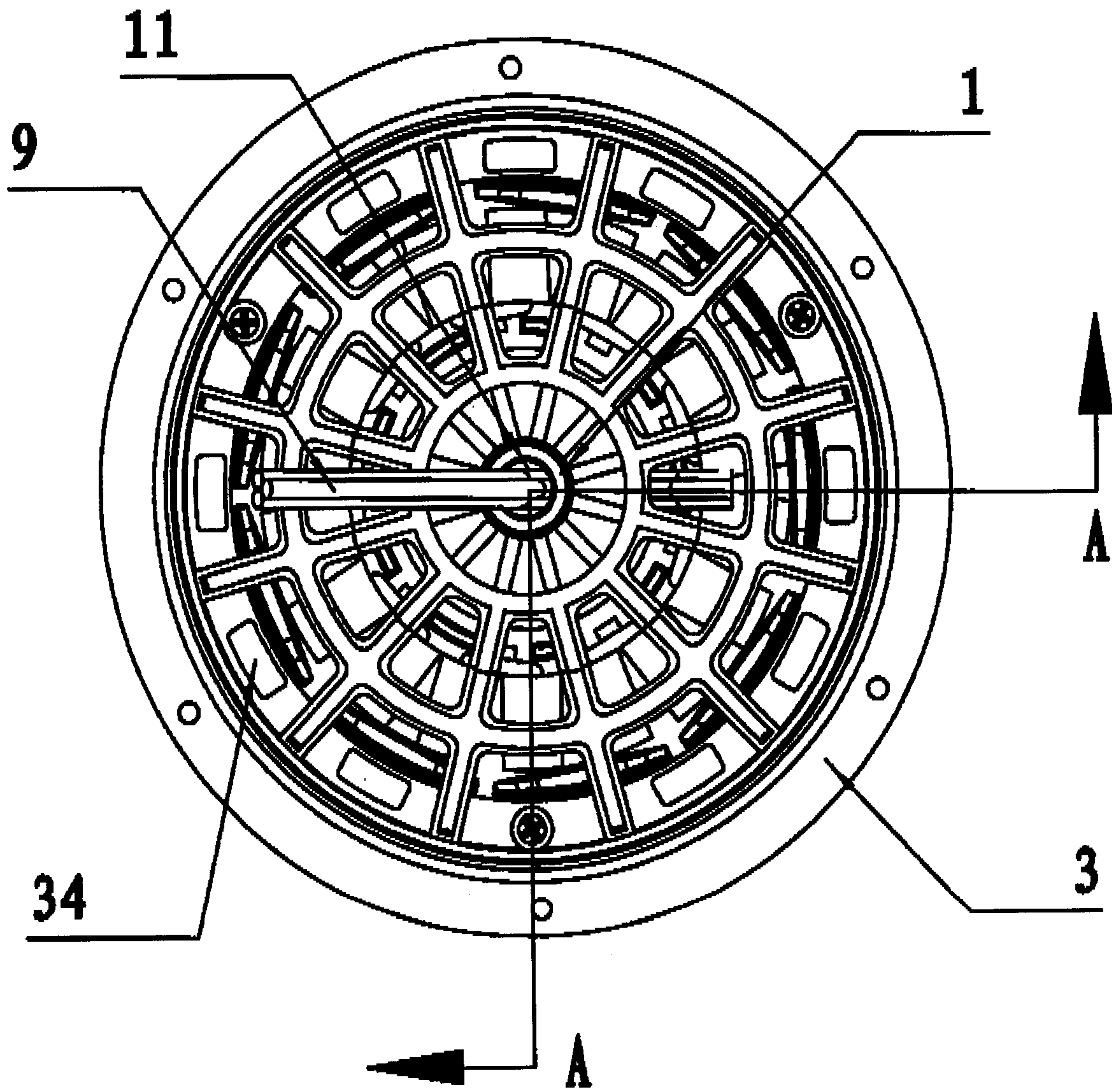

FIG. 3

4/7

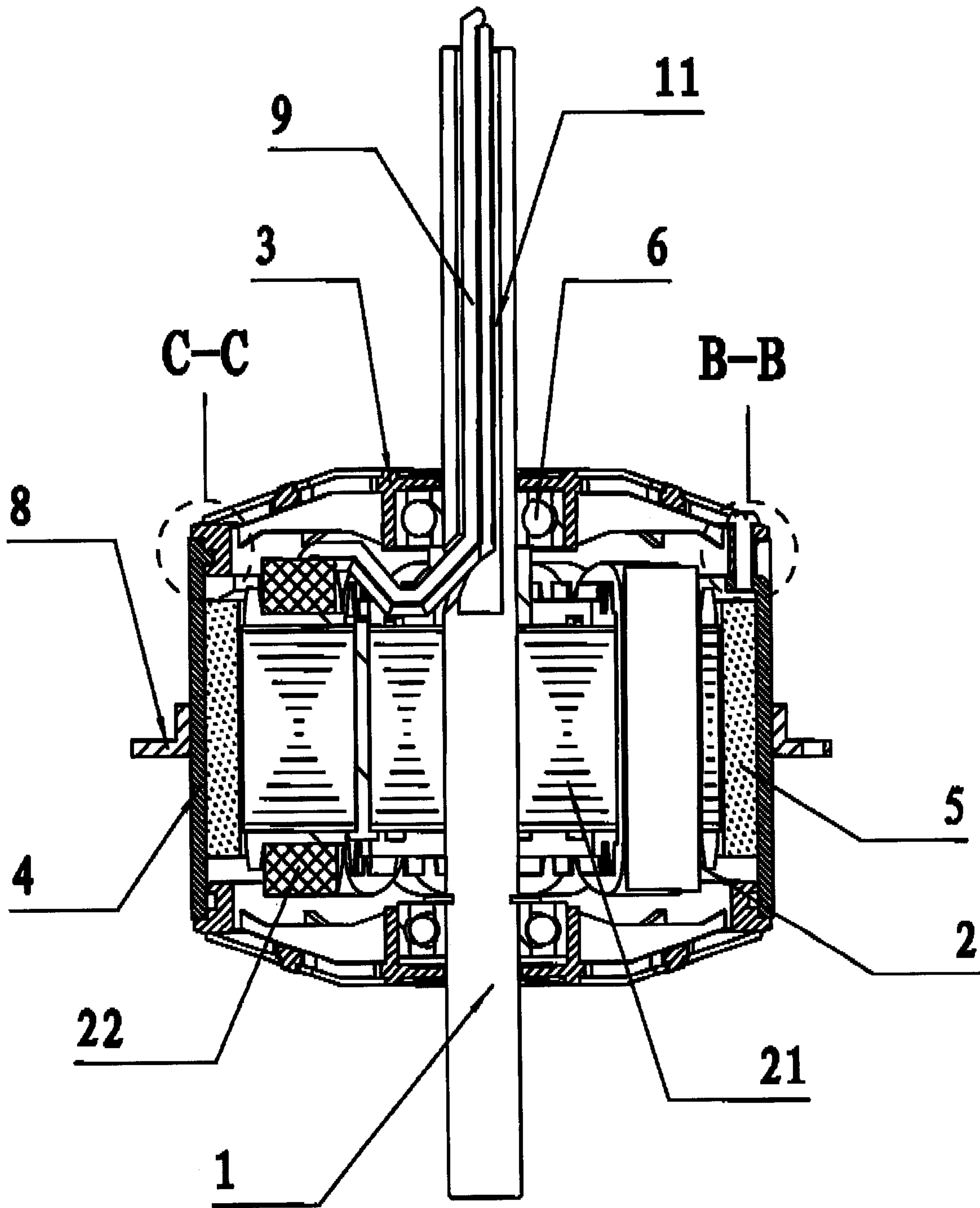

FIG. 4

5/7

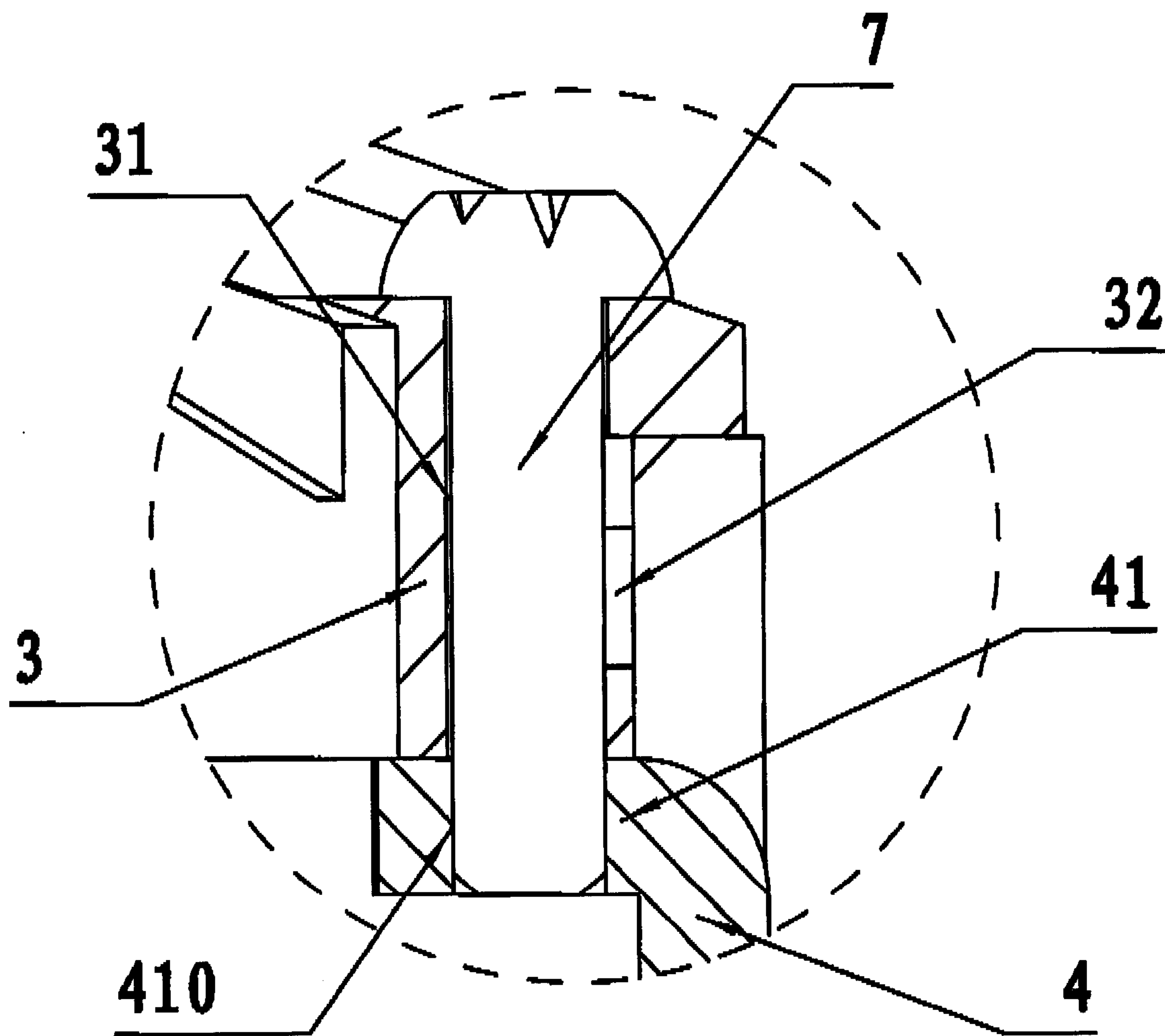

FIG. 5

6/7

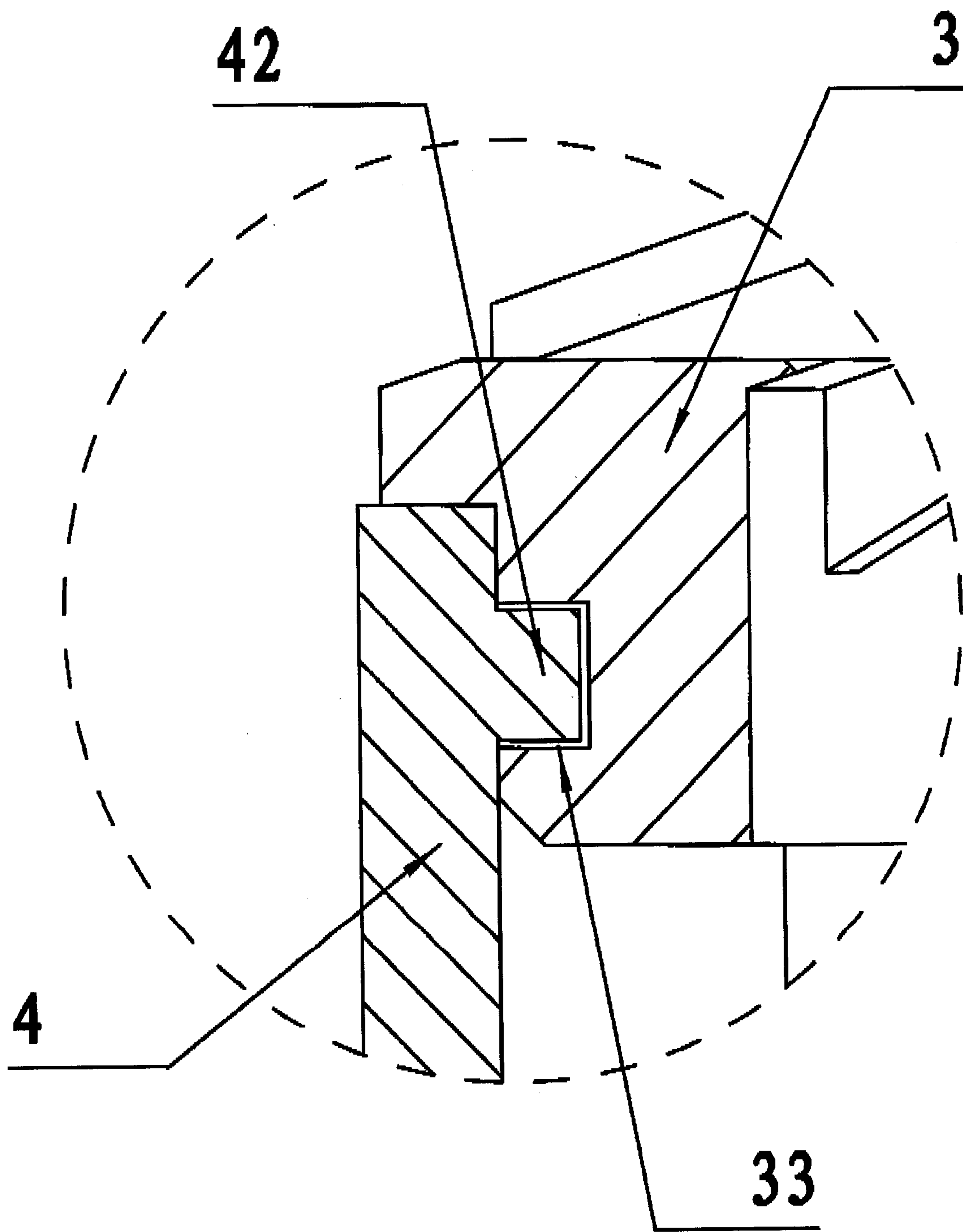

FIG. 6

7/7

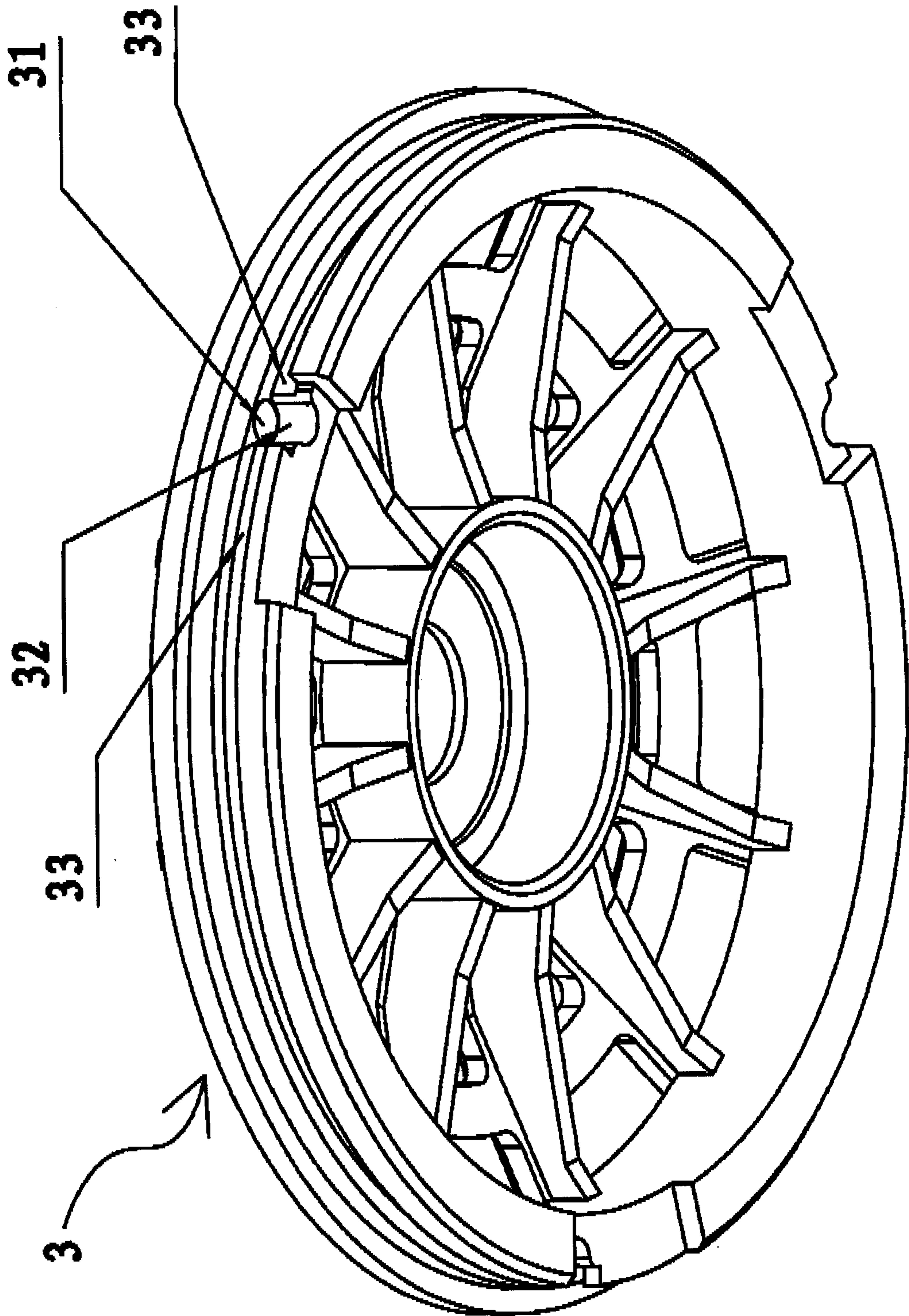

FIG. 7

