



12 **EUROPEAN PATENT SPECIFICATION**

45 Date of publication of patent specification :
25.01.95 Bulletin 95/04

51 Int. Cl.⁶ : **H01F 41/12**

21 Application number : **90312424.6**

22 Date of filing : **14.11.90**

54 **Insulating tape for winding coils.**

43 Date of publication of application :
17.06.92 Bulletin 92/25

45 Publication of the grant of the patent :
25.01.95 Bulletin 95/04

84 Designated Contracting States :
DE GB

56 References cited :
US-A- 4 269 367
PATENT ABSTRACTS OF JAPAN, vol. 3, no. 145 (E-155), 30th November 1979; & JP-A-54 124 216 (HITACHI SEISAKUSHO K.K.) 27-09-1979
PATENT ABSTRACTS OF JAPAN, vol. 3, no. 288 (E-781)[3636], 30th June 1989; & JP-A-171 112 (DENKI ONKYO) 16-03-1989
PATENT ABSTRACTS OF JAPAN, vol. 8, no. 81 (E-238)[1518], 13th April 1984;

56 References cited :
& JP-A-59 2307 (MEIJI NATIONAL KOGYO K.K.) 07-01-1984
PATENT ABSTRACTS OF JAPAN, vol. 10, no. 213 (E-422)[2269], 25th July 1986; & JP-A-61 53 713 (HITACHI) 17-03-1986

73 Proprietor : **TORAY ENGINEERING CO., LTD.**
Mitsui No. 2 Bldg.,
4-18, Nakanoshima 3-chome
Kita-ku, Osaka-shi, Osaka 530 (JP)
Proprietor : **FUJI ELECTROCHEMICAL CO.LTD.**
36-11 Shinbashi 5-chome
Minatoku Tokyo 105 (JP)

72 Inventor : **Kambara, Kenji**
35-5 Seta 3-chome
Ostu-shi, Shiga (JP)

74 Representative : **Coleiro, Raymond et al**
MEWBURN ELLIS
York House
23 Kingsway
London WC2B 6HP (GB)

EP 0 489 987 B1

Note : Within nine months from the publication of the mention of the grant of the European patent, any person may give notice to the European Patent Office of opposition to the European patent granted. Notice of opposition shall be filed in a written reasoned statement. It shall not be deemed to have been filed until the opposition fee has been paid (Art. 99(1) European patent convention).

Description

INSULATING TAPE FOR WINDING COILS

This invention relates to an insulating tape used for producing winding coils which are usually used in electric apparatus such as home electric appliances or in electronic devices used in telecommunication systems or the like.

In electric apparatus such as home electric appliances or in electronic devices used in telecommunication systems or the like, the winding coils used as the switching transformers or the like usually have the construction as shown in Fig. 3, with wirings 21 and insulated tape 22 alternately wound on a bobbin 10.

The bobbin 10 has rim portions 12 and 13 provided on both ends of a body portion 11 thereof, as shown in Fig. 4.

One of the rim portions, for example, the rim portion 12, has a plurality of terminal portions 14 projected from a side surface.

These bobbins 10 usually are given a common configuration instead of preparing several kinds of bobbins with different configurations for each winding coil. An insulating layer is usually formed on the body portion 11 of the bobbin 10 by winding narrow, insulating strips on the two side edge portions or one of the side edge portions, depending on the amount of wiring to be wound on the bobbin or the width of the winding in each winding layer.

The manufacturing steps for producing the winding coil explained above illustrated in Fig. 5-A to 5-F.

In these figures, each bobbin 10 is shown schematically. One of the rim portions 12 thereof is omitted from each drawing to make them more understandable.

First, narrow insulating strips 23 having a predetermined width are wound on both side edge portions of the body portion 11 to form ridged portions 23A and 23B, respectively (as shown in Fig. 5-A).

When an end portion of the wiring material 21 is terminated with a predetermined terminal 14, not shown in Fig. 5-B, it is wound on the body portion 11 of the bobbin 10 starting at the edge portion of the ridged portion 23A (as shown in Fig. 5-B).

After a certain amount of the wiring material 21 is wound on the body portion 11 along a longitudinal direction thereof and when the wiring material 21 reaches a position on which of end portion of the other ridged portion 23B exists (as shown in Fig. 5-C), an adhesive is coated over of whole surface of the wiring material 21 just wound on the body portion 11, then a predetermined amount of an insulating tape 22 having the same width as that of the body portion 11 is wound on the adhesive layer.

After that, the wiring material 21 is folded on the surface of the insulating tape 22 toward the terminal

14 (as shown in Fig. 5-D).

When the wiring material 21 is entangled with the terminal 14, a predetermined amount of the insulating tape 22 is wound again on the body portion 11 to cover the wiring material 21 arranged on the previously wound insulating tape 22 (as shown in Fig. 5-E).

After a first wiring layer is formed by the operation as explained above, two further narrow insulating strips 23 having a predetermined width are wound on the two end portions of the insulating tape 22 to form two further ridged portions 23A and 23B (as shown in Fig. 5-F).

Then, the wire winding operation as explained above is again carried out to form a second wiring layer, etc. Finally, a wiring coil is produced provided with a plurality of wiring layers, as shown in Fig. 3.

As explained above, the wiring coil thus produced includes the narrow insulating strips 23 which form the ridged portions 23A and 23B as insulated layers.

However, the narrow insulating strips have extremely small stiffness and strength since they are 0.05 to 1.0mm in thickness and 2 to 10mm in width.

Accordingly, when the narrow insulating strips 23 are wound on the bobbin 10 or on a surface of the wiring material 21, the insulating strips 23 are twisted even with a slight tension applied thereto. This makes it difficult for the insulating strips 23 to be wound precisely on a predetermined place.

Also, when tension is applied to the insulating strips 23, they are deformed, for example, are reduced in the thickness or the width, or are broken, to make it difficult to form a predetermined insulating layer.

Therefore insulating strips having relatively high stiffness and strength should be used. Further, the operator should wind the insulating strips on the bobbin with a great care so as not to apply unnecessary tension thereto.

These problems cause extremely low operational efficiency for producing the wiring coils.

The need to provide coil winding separated by insulation tape and including, on the bobbin, spaced apart narrow insulating strips also arises during the manufacture of transformers. Thus JP-A-1-71112 discloses the alternate application, around a bobbin of, firstly an insulation tape to which is permanently attached a pair of spaced apart narrow corrugated insulation strips which, on application, project radially outwardly of the bobbin, then an array winding of copper wire disposed on the insulation tape and between the corrugated insulation strips and then another insulation tape of the same construction as the first tape, and so on.

The present invention seeks to provide an insulating tape for winding coils which facilitates accurate winding of insulated strips on a bobbin or the like in a wiring coil producing method and further enables the winding operation to be carried out automatically.

According to one aspect the present invention provides a tape comprising a backing sheet having a predetermined width and, removably secured thereto, a strip of material provided on both surfaces of the material with adhesive, characterized in that the backing sheet has secured thereto a plurality of strips in a predetermined spaced relationship with one another, which strips are narrow strips of insulating material, two said strips being arranged at opposite longitudinal edges of the backing sheet, whereby the strips may be applied to a winding coil, the backing sheet being capable of serving as a guide sheet during the said application and thereafter being capable of removal from the strips.

According to another aspect, the invention provides a method of applying narrow strips of insulating material to a bobbin during production of a winding coil, which method comprises rotating the bobbin and supplying thereto a tape comprising a guide sheet having a predetermined width and to which the strips are secured in a predetermined spaced relationship with one another, the strips facing the bobbin during the supply thereto of the tape so as to provide on the bobbin a channel between respective strips spaced longitudinally apart from one another on the bobbin, which channel is thereby arranged to accommodate a coil of wire wound around the bobbin, characterized in that the strips have adhesive on both surfaces thereof and are releasably secured to the guide sheet, the method additionally including the steps of pressing the tape into contact with the bobbin so that the strips adhere thereto and removing the guide sheet from the tapes.

A preferred embodiment of the invention will now be described in more detail with reference to the accompanying drawings, wherein

Figure 1 is a schematic perspective view of one embodiment of an insulating tape for winding coils of the present invention;

Figure 2 is a schematic view of one embodiment of a winding operation of an insulating tape for winding coils of the present invention;

Figure 3 is a schematic cross-sectional view of one embodiment of a wiring coil;

Figure 4 is a schematic perspective view of one embodiment of a construction of a wiring coil used in the present invention; and

Figures 5A to 5F are schematic views of steps in a wiring coil producing method.

As explained above, the insulating tape 1 for winding coils of the present invention includes guide sheet 2 having a predetermined width and a plurality of narrow insulating strips 3 provided with adhesive on both surfaces thereof and removably connected to the guide sheet at predetermined spaces.

The guide (release) sheet 2 is made of a nonadhesive sheet-like material, such as paper or plastic film.

The insulating strips 3 are preferably made of an epoxy resin impregnated fabric tape. In the illustrated case they are provided along the edge margins of the sheet 2.

The insulating tape for winding coils 1 of the present invention is wound on a reel 4 or the like made of paper or plastic. At one end, there is a portion on which the narrow insulating strips 3 are not provided, to form a portion 2a to be wound on a winding reel 5.

When a wiring coil is produced utilizing the insulating tape 1, as shown in Fig. 2, the reel 4 on which the insulating tape is wound is mounted on a chuck (not shown) rotatably supported on a machine frame (not shown) or a movable arm (not shown) moving in both vertical and horizontal directions, then the end of the guide sheet 2 is withdrawn from the reel 4 and wound on a reel 5.

After this preparatory operation is completed, the wiring winding operation and the insulated tape 22 winding operation are started.

The narrow insulating strips 3 are wound on a bobbin 10 while moving a pressing means 30 or a movable arm to a surface of the bobbin 10 or a surface of wound insulated tape 22 to make the insulating strips 3 contact the surface while the bobbin is rotated.

Therefore, the insulating strips 3 are adhered to the end surfaces of the bobbin in predetermined lengths by the rotation of the bobbin 10 to form the ridge portions 3A and 3B, respectively.

After the predetermined lengths of the insulating strips 3 are wound on the bobbin 10, the rotation of the bobbin is stopped. The pressing means 30 is removed from a contact position X at which the insulating strips 3 contact the surface of the bobbin and is moved to a position Y at which the insulating strips 3 do not contact the surface of the bobbin.

Simultaneously with this movement of the pressing means 30, the insulating strips 3 are cut with a suitable cutter (not shown).

Then, the rotation of the winding bobbin 5 for winding the guide sheet 2 is stopped.

After that, the bobbin 10 is started rotating to wind the wiring material 21 delivered from a reel 40 through a suitable guide member 41 onto the surface of the bobbin 10 and between the ridge portions 3A and 3B.

After a predetermined amount of wiring material 21 is wound on the bobbin, insulating tape 22 delivered from a reel 30 through a suitable guide member 31 is wound on the bobbin 10 to cover the wiring material 21 and the ridge portions 3A and 3B.

If required, a portion of the wiring material 21 is folded on the surface of the insulating tape 22 and covered with the tape 22 during the sheet winding operation as shown in Figs. 5-D and 5-E.

Then, the pressing means 30 is again moved to the position X to bring the insulating strips 3 into contact with the surface of the insulating sheet previously

wound thereto and covering a portion of the wiring material 21 to form stacked ridge portions.

The same operation as explained above is repeated.

In this operation, the guide sheet 2 provided with the insulating strips 3 is guided by the rim portions 12 and 13 of the bobbin.

As explained above, since the insulating tape 1 of the present invention includes a guide sheet 2 having a wide width and a plurality of narrow insulating strips provided with adhesive on both surfaces thereof and since the guide sheet 2 has relatively high stiffness and high strength, there is no deformation or twisting due to tension or other external force applied thereto.

Accordingly, the narrow insulating strips can be accurately wound on the surface portion of the bobbin alongside the rim portions 12 and 13.

On the other hand, the guide sheet 2 is wound on the reel 5 after the narrow insulating strips 3 are removed therefrom and wound on the surface of the bobbin 10.

Using the insulating tape for winding coils of the present invention, the narrow insulating strips can be precisely wound at predetermined defined positions of the bobbin just by arranging an end of the guide sheet at a predetermined winding position with respect to the bobbin.

Also, an insulating layer having predetermined dimensions can be formed without deformation or twisting of the narrow insulating strips caused by tension or the like in the winding operation, since the narrow insulating strips are placed on the guide sheet.

Moreover, the operation for winding the narrow insulating strips on the surface of the bobbin can be carried out utilizing an automatic apparatus, resulting in improved production efficiency in the wiring coil production.

Claims

1. A tape comprising a backing sheet having a predetermined width and, removably secured thereto, a strip (3) of material provided on both surfaces of the material with adhesive, characterized in that the backing sheet has secured thereto a plurality of strips (3) in a predetermined spaced relationship with one another, which strips (3) are narrow strips of insulating material, two said strips being arranged at opposite longitudinal edges of the backing sheet whereby the strips (3) may be applied to a winding coil, the backing sheet being capable of serving as a guide sheet (2) during the said application and thereafter being capable of removal from the strips (3).
2. A tape according to claim 1, wherein each strip (3) consists of an epoxy resin impregnated fabric.

3. A method of applying narrow strips (3) of insulating material to a bobbin (10) during production of a winding coil, which method comprises rotating the bobbin (10) and supplying thereto a tape comprising a guide sheet (2) having a predetermined width and to which the strips (3) are secured in a predetermined spaced relationship with one another, the strips (3) facing the bobbin (10) during the supply thereto of the tape so as to provide on the bobbin (10) a channel between respective strips (3) spaced longitudinally apart from one another on the bobbin, which channel is thereby arranged to accommodate a coil of wire (21) wound around the bobbin, characterized in that the strips (3) have adhesive on both surfaces thereof and are releasably secured to the guide sheet (2), the method additionally including the steps of pressing the tape into contact with the bobbin (10) so that the strips (3) adhere thereto and removing the guide sheet (2) from the tapes.

4. A method according to claim 3, wherein two said narrow strips (3) of insulating material are arranged at respective opposite longitudinal edges of the guide sheet (2).

5. A method according to claim 3 or claim 4, wherein each strip (3) consists of an epoxy resin impregnated fabric.

Patentansprüche

1. Band, das eine Versteifungslage mit einer bestimmten Breite und einen abnehmbar daran angebrachten Streifen (3) eines Materials umfaßt, der auf beiden Oberflächen des Materials mit Klebstoff versehen ist, **dadurch gekennzeichnet, daß** an die Versteifungslage eine Anzahl von Streifen (3) in einem bestimmten räumlich getrennten Verhältnis zueinander angebracht ist, wobei diese Streifen (3) schmale Streifen eines isolierenden Materials sind, zwei dieser Streifen an den entgegengesetzten Längskanten der Versteifungslage angeordnet sind, wodurch die Streifen (3) auf eine gewickelte Spule angebracht werden können, und die Versteifungslage während des Aufbringens als Führungslage (2) dienen und danach von den Streifen (3) entfernt werden kann.
2. Band nach Anspruch 1, wobei jeder Streifen (3) aus einem mit Epoxyharz imprägnierten Gewebe besteht.
3. Verfahren zum Aufbringen schmaler Streifen (3) eines isolierenden Materials auf eine Spule (10) beim Verfahren zum Wickeln einer Spule, wobei

- dieses Verfahren das Drehen der Spule (10) und die Zufuhr eines Bandes zu dieser Spule umfaßt, das eine Führungslage (2) mit einer bestimmten Breite umfaßt und an die Streifen (3) in einem bestimmten räumlich getrennten Verhältnis zueinander angebracht sind, wobei diese Streifen (3) während der Zufuhr des Bandes zur Spule (10) zeigen, so daß auf der Spule (10) ein Kanal zwischen den entsprechenden Streifen (3) gebildet wird, die auf der Spule in Längsrichtung räumlich voneinander getrennt sind, wobei dieser Kanal dadurch so angeordnet wird, daß er eine Schleife des Drahtes (21) aufnimmt, der um die Spule gewickelt ist, **dadurch gekennzeichnet, daß** die Streifen (3) auf beiden Oberflächen Klebstoff aufweisen und lösbar an der Führungslage (2) angebracht sind, wobei dieses Verfahren außerdem die Schritte des Pressens des Bandes in einen Kontakt mit der Spule (10), so daß die Streifen (3) daran haften, und der Entfernung der Führungslage (2) von den Bändern umfaßt.
4. Verfahren nach Anspruch 3, wobei die schmalen Streifen (3) des isolierenden Materials an den entsprechenden entgegengesetzten Längskanten der Führungslage (2) angeordnet sind.
5. Verfahren nach Anspruch 3 oder 4, wobei jeder Streifen (3) aus einem mit Epoxyharz imprägnierten Gewebe besteht.
- consiste à entraîner en rotation la bobine (10) et délivrer sur celle-ci une bande comprenant une feuille de guidage (2) ayant une largeur prédéterminée et à laquelle les rubans (3) sont fixés et espacés les uns des autres d'une manière prédéterminée, les rubans (3) faisant face à la bobine (10) pendant l'amenée sur celle-ci de la bande de manière à réaliser sur la bobine (10) un canal entre des rubans respectifs (3) espacés longitudinalement les uns des autres sur la bobine, lequel canal est agencé de manière à ajuster un enroulement de fil (21) enroulé autour de la bobine, caractérisé en ce que les rubans (3) ont de l'adhésif sur leurs deux surfaces et sont fixés de manière libérable à la feuille de guidage (2), le procédé comprenant en outre les étapes consistant à presser la bande en contact avec la bobine (10) de sorte que les rubans (3) adhèrent à celle-ci et retirer la feuille de guidage (2) à partir des bandes.
4. Procédé selon la revendication 3, dans lequel deux tels rubans étroits (3) en matériau isolant sont agencés sur des bords longitudinaux opposés respectifs de la feuille de guidage (2).
5. Procédé selon la revendication 3 ou 4, dans lequel chaque ruban (3) est constitué d'un tissu imprégné de résine époxy.

Revendications

1. Bande comprenant une feuille de support ayant une largeur prédéterminée et, fixé de manière amovible à celle-ci, un ruban de matériau (3) pourvu sur les deux surfaces du matériau d'un adhésif, caractérisée en ce que la feuille de support a une pluralité de rubans (3) fixés sur celle-ci et espacés les uns des autres d'une manière prédéterminée, lesquels rubans (3) sont des rubans étroits en matériau isolant, deux tels rubans étant agencés sur des bords longitudinaux opposés de la feuille de support, de sorte que le ruban (3) puisse être appliqué à une bobine d'enroulement, la feuille de support étant apte à servir comme feuille de guidage (2) pendant ladite application et par la suite étant apte à être retirée à partir des rubans (3).
2. Bande selon la revendication 1, dans laquelle chaque ruban (3) est constitué d'un tissu imprégné de résine époxy.
3. Procédé d'application de rubans étroits (3) en matériau isolant sur une bobine (10) pour produire une bobine d'enroulement, lequel procédé

Fig. 1

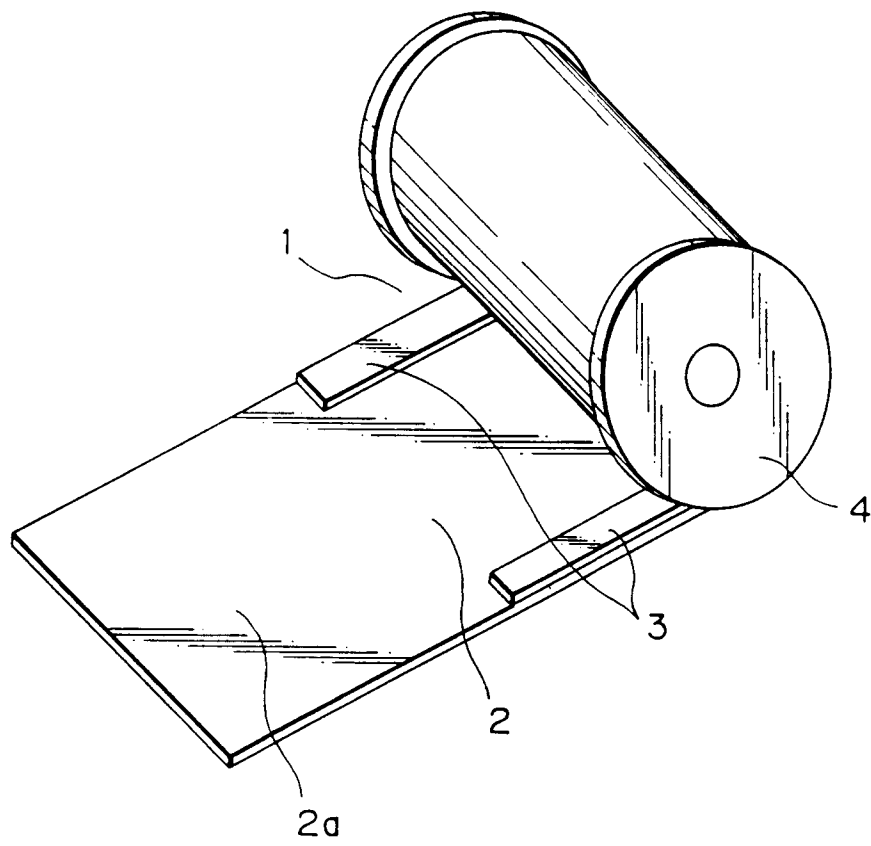

Fig. 2

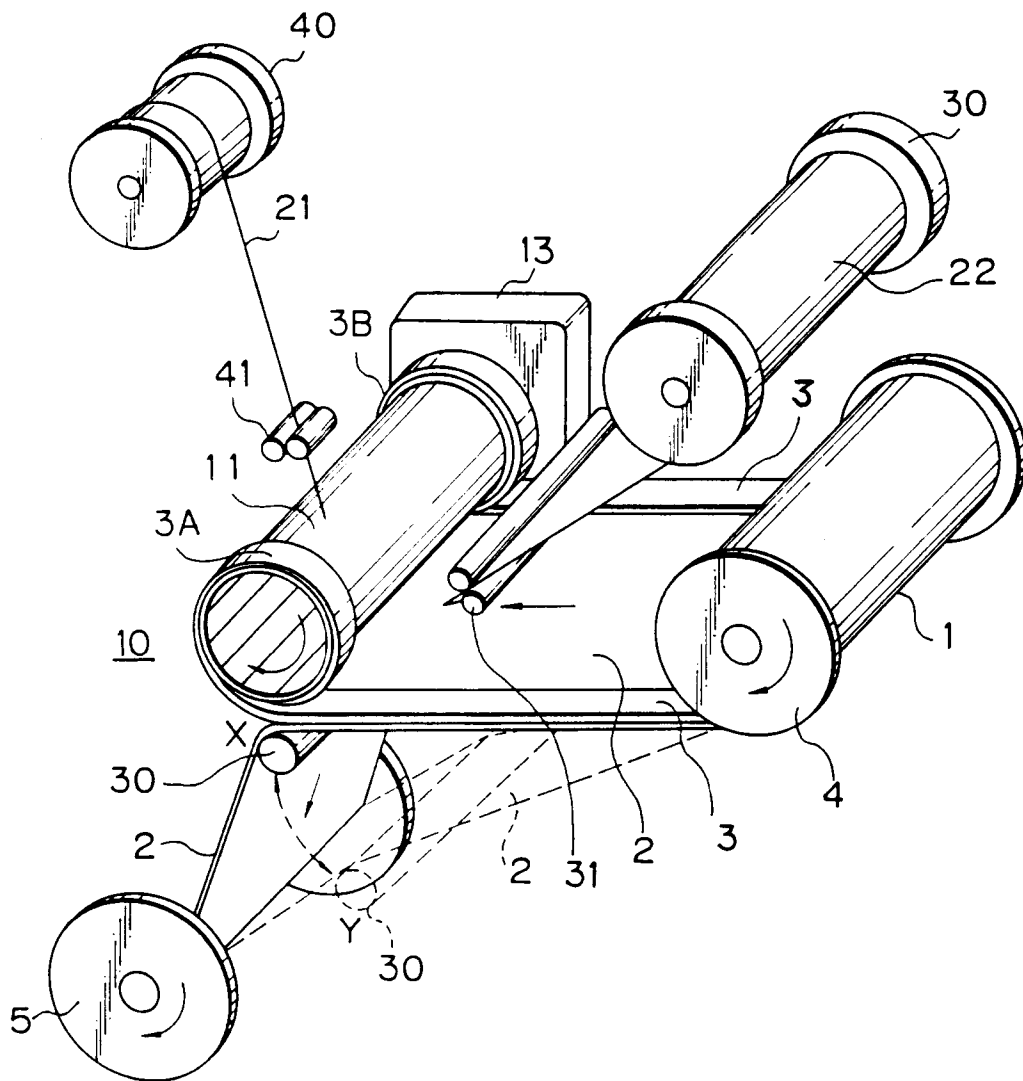

Fig. 3

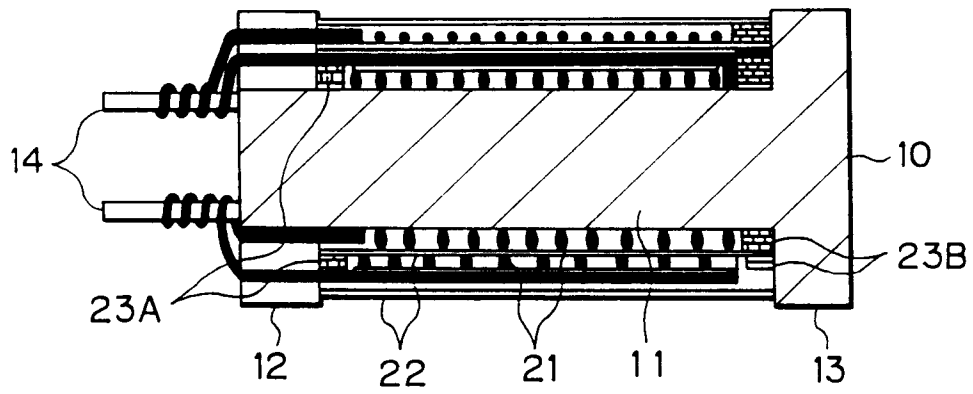

Fig. 4

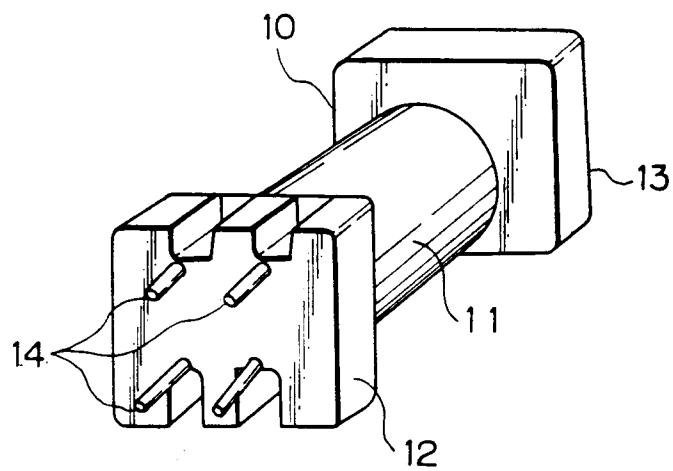

Fig. 5

