

19



Europäisches Patentamt
European Patent Office
Office européen des brevets

11 Publication number:

0 348 612
A2

12

EUROPEAN PATENT APPLICATION

21 Application number: 89106634.2

51 Int. Cl.4: B01L 3/02

22 Date of filing: 13.04.89

The title of the invention has been amended (Guidelines for Examination in the EPO, A-III, 7.3).

30 Priority: 15.04.88 PL 271845

43 Date of publication of application: 03.01.90 Bulletin 90/01

84 Designated Contracting States: DE FR GB

71 Applicant: PRZEDSIĘBIORSTWO POLONIJNO ZAGRANICZNE PLASTOMED
ul. Daniszewska 4
PL-03-230 Warszawa(PL)

72 Inventor: Sarna, Wojciech
ul. Raclawicka 4 m. 28
PL-02-601 Warszawa(PL)

74 Representative: Finck, Dieter et al
Patentanwälte v. FÜner, Ebbinghaus, Finck
Mariahilfplatz 2 & 3
D-8000 München 90(DE)

54 Pipette.

57 The present invention solves the problem of working out a design of a plain pipette which serves for drawing in, pipetting and dispensing the fluid of a strictly specified volume and which is characterized by a high repeatability of results.

The said pipette consists of a round casing /1/ being simultaneously a handle thereof, whereto, via a round nut /2/, there is fitted a multi-step shank /3/. Inside the body of casing /1/, there is a plunger /4/, being in the form of a multi-step rod, which is being displaced downwards with the aid of a press means /16/ and of a round arbor /15/, contrary to the force being exerted by a lift-up spring /13/ which makes plunger /4/ return to its initial position. Furthermore, inside the body of casing /1/, centrally in the symmetry axis of the pipette, directly under press means /16/, there is a calibration unit comprising a multi-step calibration sleeve /19/, which is blocked from the top by a hold-down element /24/, being screwed into the body of casing /1/, inside whereof there freely slides an arbor /15/ being connected to press means /16/.

The end of arbor /15/ is placed inside an elongated sleeve being a push rod /14/, which from the top rests with its flange upon the face of a stop /20/ being screwed into the internal thread of calibration sleeve /19/.

From the top, upon the flange of push rod /14/, the pressure is being simultaneously exerted by a blow-out mechanism spring /22/, which from the top rests upon a washer /18/ being blocked by a ring /17/. The lower part of push rod /14/ gets in contact with a plunger's flange /10/, whereas between plunger's flange /10/ and the end of arbor /15/ there is a narrow slot /23/.

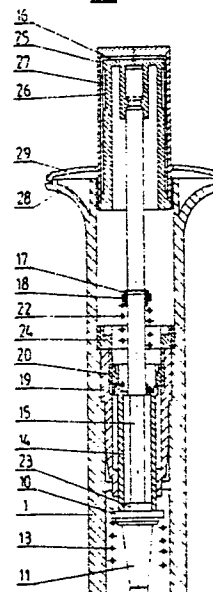

Fig. 2

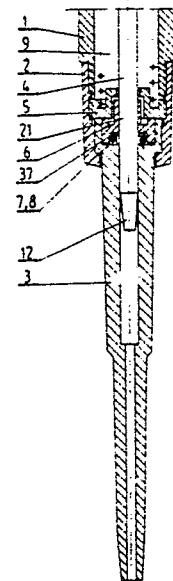

Fig. 3

EP 0 348 612 A2

A PLAIN PIPETTE

The subject of the invention is a plain pipette being a laboratory instrument and serving for drawing in, pipetting and dispensing the fluid of a strictly specified volume.

From the FRG patent specification No. 2,921,442 there is known a plain volume-controlled pipette, which consists of a casing, being simultaneously a hand grip, in its lower end comprising a joint cylinder with tubular terminals; of a piston placed in the said cylinder, being pressed down by means of a push and of a piston rod, contrary to the force being exerted by a spring, which urges the piston to return to its upper position; of an upper internal thread reducer sleeve, which is screwed upon the piston rod threading and which defines the upper position of the piston. The upper sleeve and the casing are provided with a cooperating groove/projection assembly, which prevents turning thereof but enables the movement of the sleeve along the piston rod, and thereby, after turning the push which defines the upper position of the piston, the sleeve can be displaced up and down relative to the piston rod, changing the pipette's volume which is monitored on the scale in the casing.

In the course of pipetting, the push is pressed, what makes the sleeve and piston move downward until the push is pressed down to a support. Starting from this point, it is possible to further press down the push of the piston, together with a portion of the support being outside the end of the casing. The upward movement of the piston is limited by a flange in the casing, whereto the upper reducer sleeve is pressed, on return of the piston to its upper position.

From the other FRG patent specification No. 2,549,477, there is known a hand-held pipetting device, comprising a slim, conical body, the upper portion whereof is a handle, while the lower portion is terminated with an outlet member projecting outside the body, whereon a replaceable working tip of the pipette is fitted. Inside the body, there is mounted a dispensing mechanism being activated by means of a push projecting over the upper portion of the body. The mechanism of the pipette principally consists of a few operating systems placed in tandem on a single axis running alongside the whole symmetry axis of the pipette. The upper part of the mechanism constitutes the dosage measuring system. The said system comprises a piston rod being terminated with a push projecting over the body, a return spring being fitted on the piston rod and a limiter with a hole in its bottom, wherethrough there passes the end of the piston rod. In the lower part, along the height of the

limiter, on the periphery of the piston rod, there are six stops, being symmetrically spaced in pairs, having the three different heights determining the three different lengths of stroke of a plunger. Whereas in the bottom of the limiter, there are made pass-through conduits corresponding to the spacing of the two pairs of stops. In the body above the limiter, there is screwed a constant ring setting the upper basic position of the plunger and the whole mechanism. The said ring and limiter are made as permanent magnets, and the limiter mechanism in its state of rest, due to the magnetic field effect, adheres with its upper flange periphery to the cylindrical stop.

Another solution is known from the US patent specification No. 4,009,611. The pipetting and blowing mechanisms are in fact placed on a single axis, but they are completely separated from the release mechanism of the actuating tip.

A pipette, as disclosed in the US patent specification No. 4,009,611, has a cylindrical body being a handle and an outerly step-by-step slimmer cylinder, being an elongation thereof, with a correspondingly step-by-step slimmer ejector's sleeve, being mounted thereon. Inside the body there is placed a long piston rod also terminated with a long rod plunger embedded into the cylinder, and periphery sealed from the top of the system.

Into the upper part, inside the body, a sleeve is forced, the length whereof is determined by the plunger's one-length stroke. Under the sleeve, there is a movable ring threaded through the piston rod and held down from the bottom by means of a spiral spring in such a manner that a separable sleeve bottom is formed. Beneath the ring there is another sleeve, being also permanently forced inside the body. Inside the said sleeve there is a return spring mounted on the piston rod, with its lower end resting upon the bottom of the body, whereas with its upper end resting upon a peripheral limiter, being fitted on the piston rod beneath the ring which forms the bottom of the upper sleeve. The upper end of the piston rod passes through the interior of the upper sleeve and projects above the body, where the piston rod is terminated with a push. The said push is a right-angled triangle in cross-section with a rounded and profiled leg for better support of a thumb. On the piston rod, in the upper sleeve area, there is fitted a ring-shaped stop, which in the state of rest of the mechanism is by means of return springs held down to the upper inner wall of the body.

Furthermore, from the Polish patent application No. P. 242,647, there is known a laboratory micropipette for drawing in the dispensing the predeter-

mined volumes of fluid with a high precision rate.

The said laboratory micro-pipette is characterized in that in the upper separable two-segment body, in the portion above the piston, there is a partition wall, whereunder there is placed a main spring co-operating with the piston.

Above the partition wall, there is an auxiliary spring acting upon the sleeve, being centrally and movably placed inside the piston stroke control spring which is screwed in the aperture of the upper portion of the body, above the auxiliary spring. Inside the sleeve there is centrally placed a movable push rod of the piston, provided with a push head.

The hitherto-known pipettes are of a quite complicated design as they comprise a great number of component parts. Moreover, in the hitherto-known solutions of pipettes, the pressing movement is at length accompanied by the movement of a plunger. The force barrier is carried out by a bending stop. It results in a risk of weaker or stronger pressing down to a stop because of a fear of exceeding the force barrier, and the steps of pressing movement are not properly differentiated, what makes it possible that a high repeatability of results in drawing in the fluid for examination is not entirely ensured.

The plain pipette as per the present invention is characteristic by the fact that in the middle of the symmetry axis of the body of the casing, right under a push, there is a calibration unit.

The said calibration unit comprises a multi-step calibration sleeve resting upon the inner projection of the body of the casing, the said sleeve being blocked from the top by means of a hold-down element being screwed into the body of the casing. Inside the calibration sleeve, there freely slides an arbor which is connected to a press means, being with a part of its flattened diameter placed inside a flattened oblong sleeve being a push rod, which from the top rests with its flange upon the face of a stop, being screwed into the internal thread of the calibration sleeve. From the top, upon the flange of the push rod, pressure is exerted by the blow-out mechanism spring, which from the top rests upon a multi-step washer being blocked by a ring which is slid into the recess of an arbor. The lower part of the push rod contacts the flange of the plunger, whereas there remains a narrow slot between the said flange and the end of the arbor. The inner bottom flange of the calibration sleeve forms a resistance point for the push rod, being displaced downwards together with the arbor. The plunger of the pipette comprises a two-step flange and a truncated cone portion, being with its smaller diameter directed towards the oblong arbor of the plunger terminated with the other conical portion. At the place of joint of the body of the casing and

of a shank, there is a plunger sealing unit, comprising a nut with a flanged sleeve screwed into the internal thread thereof, being a hold-down element, which through the said sleeve presses down the ring and the sealing sleeve to the face of the main body.

In the other version of the pipette as per the present invention, a plunger comprises a two-step flange, a short cylindrical portion and then an oblong arbor and a thin plunger rod. At the place of joint of a body of a casing and of a shank, there is a plunger sealing unit comprising a nut, inside whereof a hold-down element is screwed, which through a spring exerts pressure upon a hold-down sleeve, which, being slid into the hole of the shank, presses down the ring and the sealing sleeve to the face of the shank. The press means of the pipette is in the shape of a round, one end-closed sleeve, wherefrom the inside an arbor is rigidly fitted. From the outside, it has a transparent plastics cover mounted thereon. At the top, around the periphery of the press means, there is a rectangular groove, wherein an information strip is placed.

The pipette as per the present invention, due to its plain design, is technologically more feasible.

Moreover, the pipette as per the present invention, due to the application of a calibration unit, in the course of pressing down the press means, is capable of differentiating the three steps of movement and the two force barriers and of separating them, where only the first and the third step of pressing movement is accompanied by the movement of the plunger. In the second step of movement of the said plunger, the pipette performs an idle movement, which separates the draw-in cycle from the blow-out cycle. By such a capability of the pipette, a high repeatability of results in the course of operation in drawing in the fluid for examination is ensured.

The subject of the invention is presented in the example of embodiment in the drawing, where

Fig. 1 is a plain pipette in view,

Fig. 2 and 3 - is the plain pipette in a long-operation cycle in its longitudinal section,

Fig. 4 and 5 - is the plain pipette in a short-operation cycle in its longitudinal section,

Fig. 6 - is a calibration unit in the state of rest in its along-axis section,

Fig. 7 - is the calibration unit in the first step of movement of the press means in its along-axis section.

Fig. 8 - is the calibration unit in the second step of movement of the press means in its along-axis section, and

Fig. 9 - is the calibration unit in the third step of movement of the press means in its along-axis section.

In Figs. 1, 2 and 3, the plain pipette is shown

which serves for drawing in the fluid within the range of 100 - 1000 μ l. It comprises a round body of a casing 1, which is made of plastics material, simultaneously being a handle for the persons applying it. To the lower portion of the body of casing 1, a shank 3 is fitted through a round nut 2 being screwed into the end of the body of casing 1, being in the shape of a step-by-step elongated sleeve. Inside nut 2, there is a sealing unit of a plunger 4, which comprises a hold-down element 5 being in the shape of a flanged sleeve. Hold-down element 5, being screwed inside the internal thread of nut 2, through a sleeve 6 presses down a ring 7 and a sealing sleeve 8 to the face of shank 3, which together seal the arbor of plunger 4, which slides into the opening of shank 3. The free end of shank 3 is made in such a manner that it enables inserting therein a tip for drawing in the examined fluid, not being shown into the drawing.

Inside the body of casing 1, being a cylinder 9, there is placed a plunger 4. Plunger 4 consists of a two-step flange 10 being connected to a conical portion 11 which is narrower towards the bottom, and then of a cylindrical portion being an arbor 21, which is again at the bottom terminated with a conical portion 12 being narrower towards the bottom. On the side of conical portion 11, resting from one side on flange 10 and from the other side on hold-down element 5, there is a cylindrical spring 13 lifting plunger 4 upwards. From the top, flange 10 is pressed down by a push rod 14 provided with an arbor 15, which has a press means 16 fitted upon its upper end, whereas the movement of push rod 14 and arbor 15. Arbor 15 is in the shape of a two-step round rod, having an undercut in the fitting place of pressing element 16, and the other one in the fitting place of ring 17, and of a step washer 18. Directly beneath press means 16, there is a calibration unit, serving to impart the particular stages of movement to plunger 4 which comprises a multi-step calibration sleeve 19, being inserted inside the body of casing 1, inside whereof there is screwed a short step 20 being in the shape of a sleeve. Inside the calibration unit, arbor 15 is placed with its bigger diameter in the middle of elongated push rod 14, being in the shape of a step sleeve which is pressed down from the top to the flange of arbor 15 by means of a blow-out mechanism spring 22. The flange of push rod 14, being in the state of rest, rests upon the face of short stop 20. At the same time, push rod 14, through plunger flange 10, is pressed from the bottom by lift up spring 13, whereas there remains a narrow slot 23 between plunger flange 10 and the end of arbor 15. The inner flange of a calibration sleeve 19 forms a lower resistance point for push rod 14 sliding down together with arbor 15. The calibration unit is closed from the top by a hold-

down element 24 which is screwed into the internal thread of the body of casing 1, the said element being in the shape of a nut, which blocks calibration sleeve 19 from the top. Simultaneously, the blow-out mechanism spring 22 rests upon step washer 18, which slides down along arbor 15, and is displaced relative to calibration sleeve 19 together arbor 15.

At the end of arbor 15 there is rigidly mounted a press means 16, serving for actuating the pipette, which slides along the body of casing 1. Press means 16 is in the form of a round sleeve, being closed from the top. From the outside, a transparent plastics cover 25 is put upon press means 16.

In the upper part, around its periphery, press means 16 has a rectangular groove 26, wherein information strip 27 is placed, showing the pipette's volume.

At the top of casing 1, at the point where press means 16 is fitted, there are hand grips 28 placed on both sides of casing 1, being in the form of wings with half-round lower surfaces making handling the pipette easier, which are integrated with the body of casing 1, forming together a handle. The both hand grips 28 are covered from the top with a rectangular cover 29.

In Figs. 1, 4 and 5 a plain pipette is shown, which serves for drawing in small volumes of fluid ranging 5 + 50 μ l, which is different by the design of plunger 4, by the manner of sealing plunger 4 in handle 3, and which is provided with stop 30. Plunger 4 is in the form of multi-step arbor, which consists of two-step flange 10, whereon lift-up spring 13 is supported, and further of a short cylindrical portion 31 being terminated with an elongated arbor 32, having a thin arbor of plunger 4 at its end, which slides in the opening of shank 3. At the place of point of the body of casing 1 and of shank 3, there is a sealing unit of the arbor 21, comprising nut 6 being screwed onto the body of casing 1, inside whereof hold-down element 5 is screwed being in the form of a sleeve with its flange turned down, whereon lift-up spring 13 is supported. Hold-down element 5, through spring 33, exerts pressure on hold-down sleeve 34, which is slid inside the first opening of shank 3 and then it presses down a ring 35 and a sealing sleeve 36 to the face of shank 3, the said elements sealing the arbor 21 of plunger 4, which slides in the other opening of shank 3.

The above disclosed plain pipette operates in the following manner: when the pressing element is being pressed down, the three steps of movement are differentiated, being separated therefrom by the two force barriers.

Fig. 6 is a calibration unit of the pipette in its state of rest, when press means 16 is extended and in Fig. 7 the first step of movement of press

means 16 is shown. The pressing down movement of press means 16 is accompanied by the movement of push rod 14. The flange of push rod 14 is detached from the surface of stop 20 or 30. Push rod 14 actuates plunger 4 causing lift-up spring 13 bend down. The first step of movement is over when the flange of push rod 14 rests upon the projection of calibration sleeve 19. Then the first force barrier is sensed. On release of press means 16, in this step of movement, the fluid is drawn in. Fig. 8 shows the second step of movement of press means 16. When press means 16 is being pressed down, the pretension of blow-out mechanism spring 22 is to be overcome, the said spring causing the first force barrier. On passing thereof, the movement of press means 16 causes arbor 15 displace relative to immovable push rod 14. At that moment, blow-out mechanism spring 22 of plunger 4 is bent down, whereas plunger 4 remains in the state of rest. The second step of movement continues up to the moment of contact of the face of arbor 15 with plunger's flange 10. Then the second force barrier is sensed. The second step of movement is separated by the first and the third force barrier. In this step of movement no operation of the pipette occurs; it is a protective step. Fig. 9 is the third step of movement of press means 16. When press means 16 is being pressed down, the second force barrier is to be further overcome.

At the moment when plunger 4 starts to be pushed by the face of arbor 15, both springs: lift-up spring 13 and blow-out mechanism spring 22 start to operate in a parallel system and not in a series system as before. The tension of lift-up spring 13 is added to the tension of blow-out mechanism spring 22. On crossing the second force barrier, arbor 15 drives plunger 4 up to the moment when press means 16 rests upon hold-down element 24. The movement is terminated then. This additional step of movement serves to exactly clean the pipette from the remaining fluid. Only the first and the third step of movement of press means 16 is accompanied by the downward movement of plunger 4. Therefore, when press means 16 is being pressed down, for drawing in the fluid the first force barrier is to be always crossed and press means 16 is to be stopped before reaching the second force barrier. It ensures obtaining a higher repeatability of results.

Claims

1. A plain pipette consisting of a round casing being simultaneously a handle thereof, said casing in its lower end comprising a tubular multi-step shank being connected to said casing, inside whereof there is a plunger in the form of a round rod, a

press means, a straight arbor and a main spring together with an auxiliary spring, and a movable sleeve being placed onto the arbor in the upper part of said casing, characterized in that centrally in the symmetry axis of the body of a casing /1/, directly under a press means /16/ there is a calibration unit comprising a multi-step calibration sleeve /19/ resting upon the inner projection of the body of casing /1/, which is blocked from the top by a hold-down element /24/ being screwed into the body of casing /1/, inside said calibration sleeve in arbor /15/ being slidably mounted and connected to press means /16/, said arbor being placed inside an elongated sleeve being a push rod /14/, which from the top rests with its flange upon the face of a stop /30/ being screwed into the internal thread of calibration sleeve /19/, and simultaneously, from the top, upon the flange of push rod /14/ a pressure is being exerted upon a blow-out mechanism spring 22/, which from the top rests upon a step washer /18/, said washer being blocked by a ring /17/ which is slid into a recess of arbor /15/, and simultaneously, from the bottom, push rod /14/ gets in contact with a plunger's flange /10/, whereas between plunger's flange /10/ and the end of arbor /15/ there is a narrow slot /23/, while the inner lower flange of calibration sleeve /19/ constitutes a resistance point for push rod /14/ being displaced downwards together with arbor /15/.

2. The pipette as per Claim 1, characterized in that plunger /14/ comprises a two-step flange /10/, a conical portion /11/ in the form of a truncated cone, being with its smaller diameter directed towards an oblong arbor /21/ of plunger /4/ which is terminated with the other conical portion /12/, whereas at the place of joint of the body of casing /1/ and of a shank /3/ there is a sealing unit /37/ of plunger /4/.

3. The pipette as per Claim 2, characterized in that sealing unit /37/ of plunger /4/ comprises a nut 2/ which via threading connects the body of casing 1/ to shank /3/, whereas into the internal thread of nut 2/ there is screwed a flanged sleeve being a hold-down element /5/, which through a sleeve /6/ presses down a ring /7/ and a calibration on sleeve 8/ to the face of shank /3/.

4. The pipette as per Claim 1, characterized in that plunger /4/ comprises two-step flange /10/, a short cylindrical portion /31/, and further an elongated arbor /32/ and a thin arbor of plunger /4/, whereas at the place of joint of the body of casing /1/ and of shank /3/ there is sealing unit /37/ of plunger /4/.

5. The pipette as per Claim 1 or 2, characterized in that sealing unit /37/ of plunger /4/ comprises nut /2/, which via threading connects the body of casing /1/ to shank /3/, said nut having

hold-down element 15 inside, which further on via spring 33 presses a hold-down sleeve 34, which, being slid into the aperture of shank 3, exerts pressure upon the face of shank 3, upon ring 35 and upon sealing sleeve 36.

5

6. The pipette as per Claim 1, characterized in that press means 16 is in the form of a round, one end-closed sleeve, whereto, from the inside, there is rigidly mounted arbor 15, whereas from the outside it has a transparent plastics cover 25 fitted, while at the top, around the periphery of press means 16, there is a rectangular groove 26, wherein there is placed an information strip 27.

10

15

20

25

30

35

40

45

50

55

6

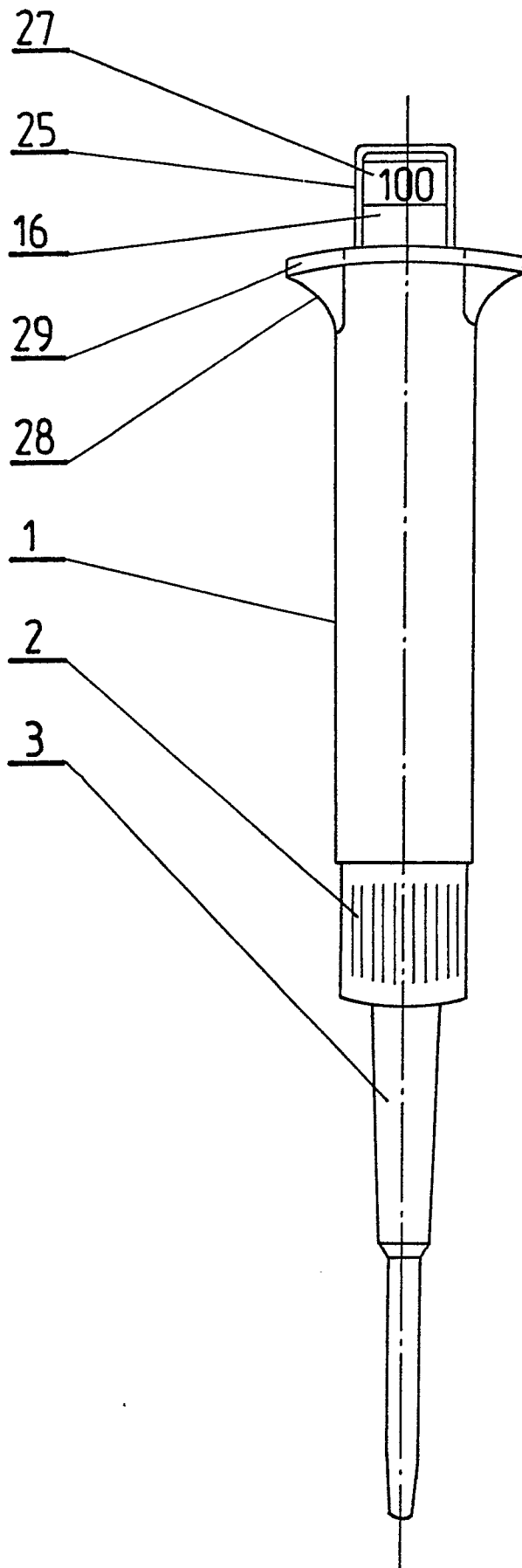

Fig. 1

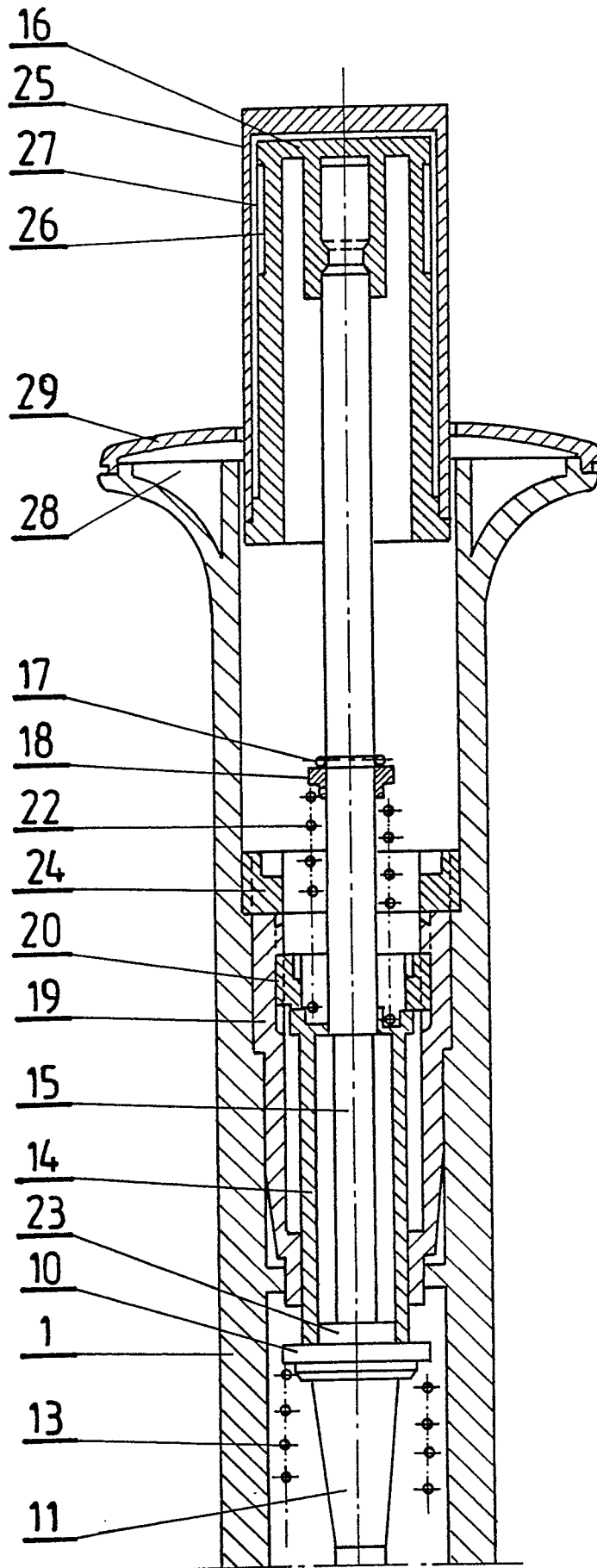

Fig. 2

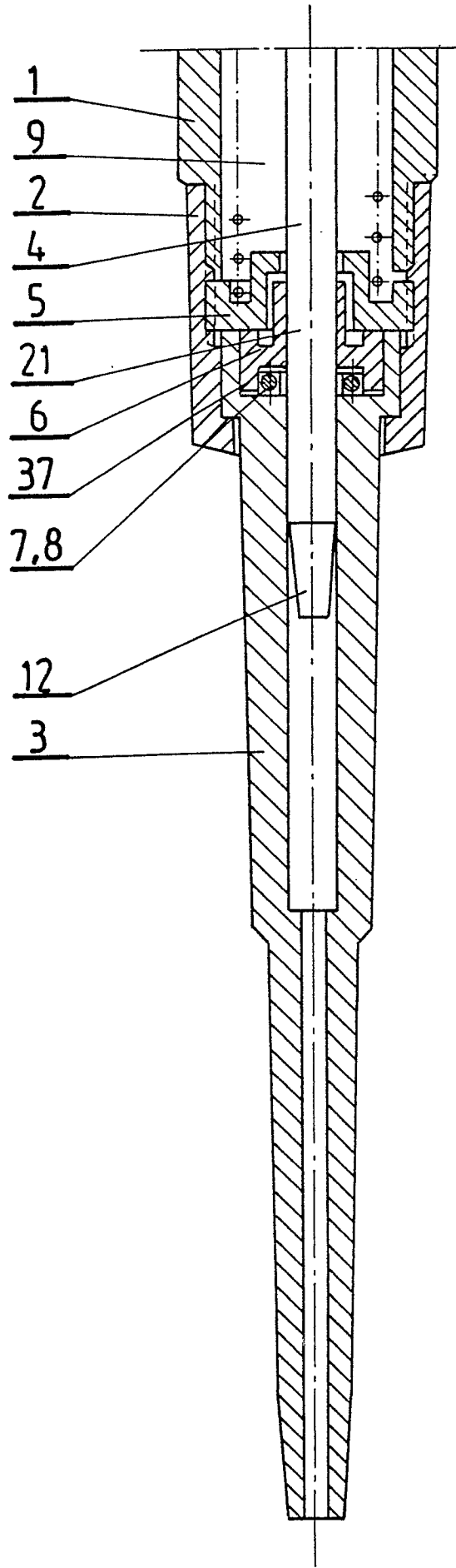

Fig. 3

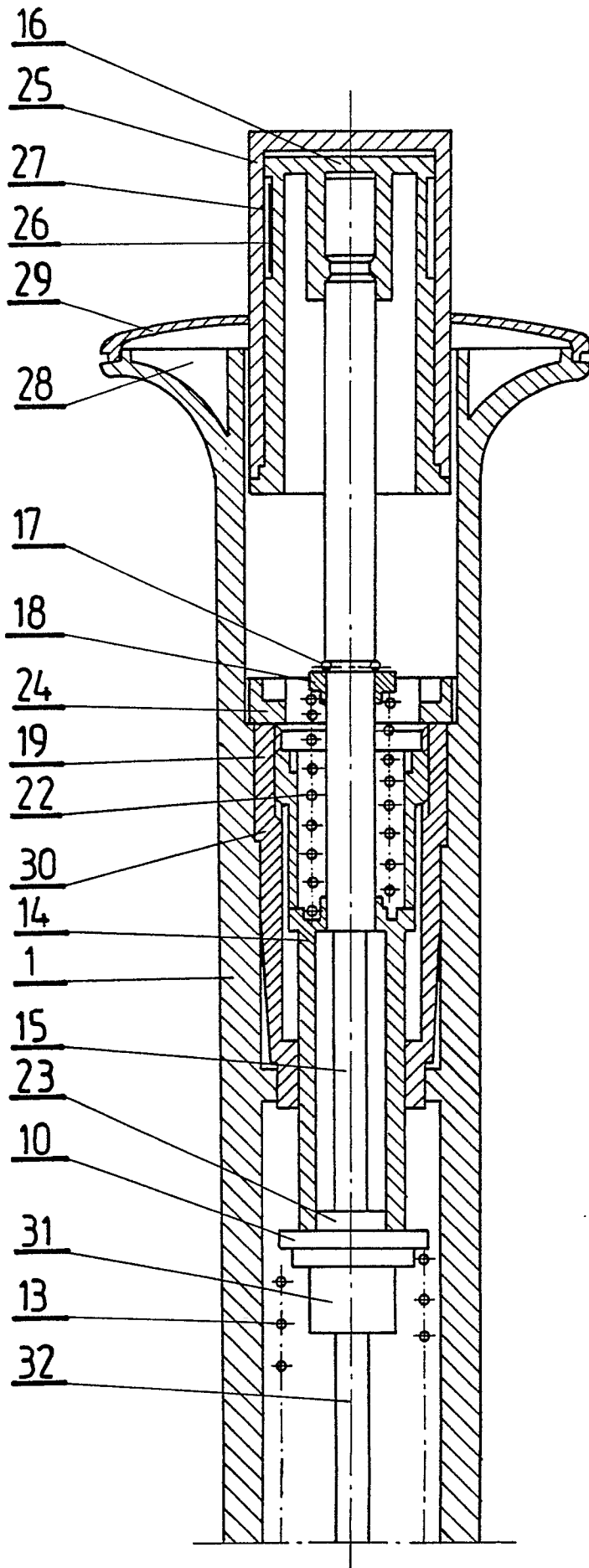

Fig. 4

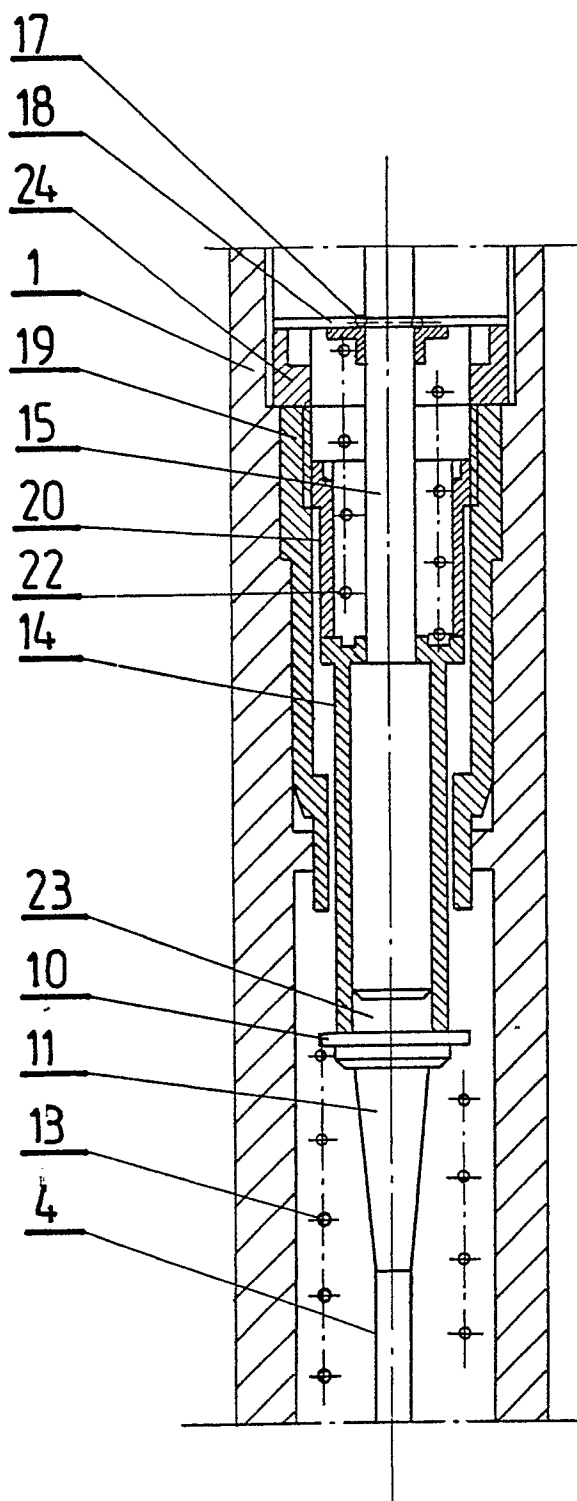

Fig. 6

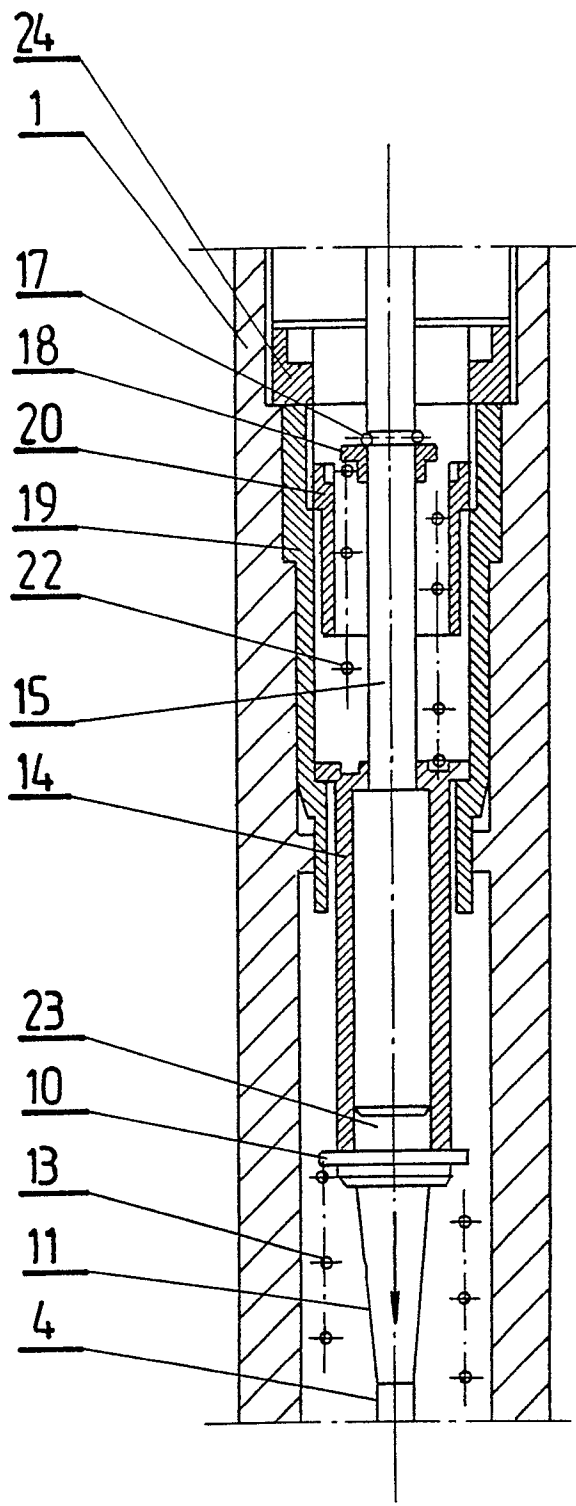

Fig. 7

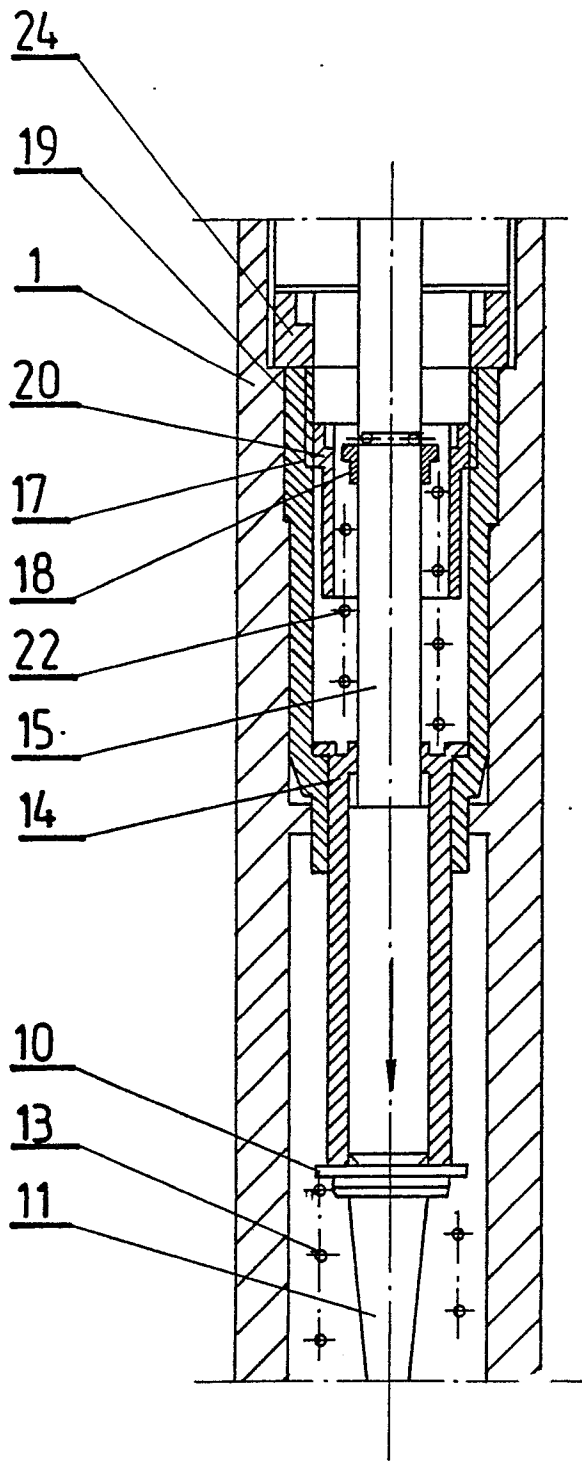

Fig. 8

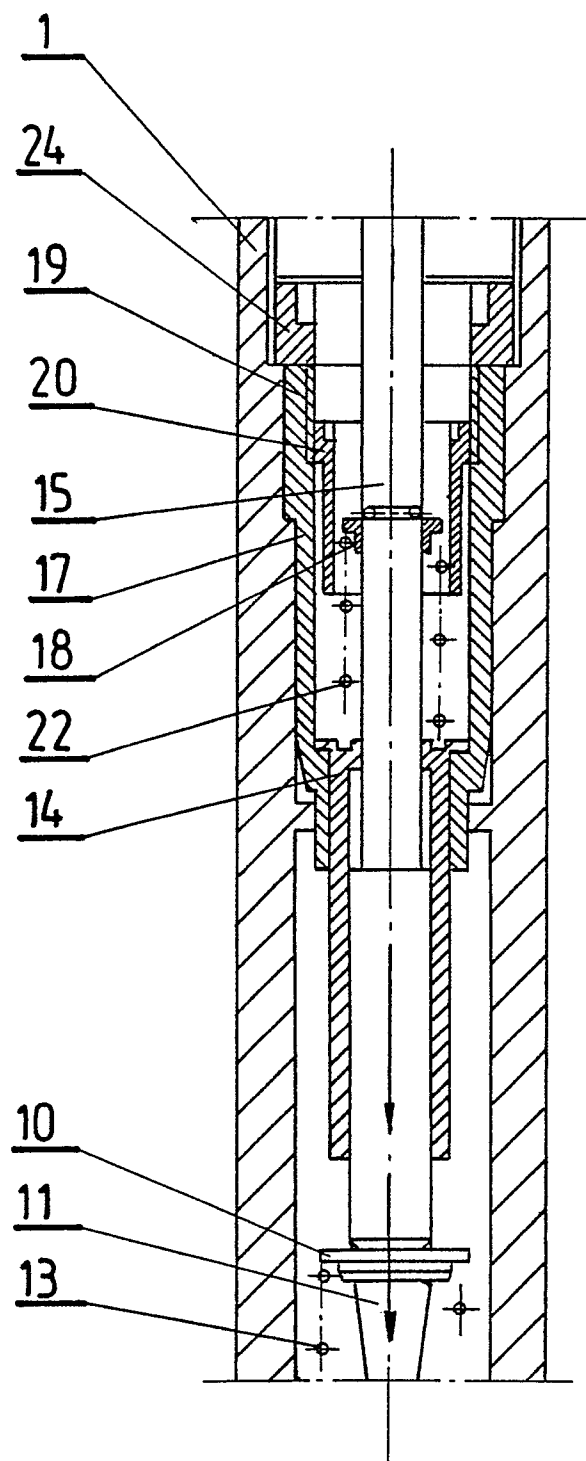

Fig. 9