

(19) World Intellectual Property Organization  
International Bureau



(43) International Publication Date  
26 June 2008 (26.06.2008)

PCT

(10) International Publication Number  
WO 2008/074926 A1

- (51) International Patent Classification:  
E04C 2/292 (2006.01) E04B 1/68 (2006.01)  
E04B 1/61 (2006.01) E04F 13/08 (2006.01)
- (21) International Application Number:  
PCT/FI2007/050713
- (22) International Filing Date:  
20 December 2007 (20.12.2007)
- (25) Filing Language: English
- (26) Publication Language: English
- (30) Priority Data:  
20065833 21 December 2006 (21.12.2006) FI  
20075145 27 February 2007 (27.02.2007) FI
- (71) Applicant (for all designated States except US):  
RAUTARUUKKI OYJ [FI/FI]; Suolakiivenkatu 1,  
FI-00810 Helsinki (FI).
- (72) Inventor; and
- (75) Inventor/Applicant (for US only): URBANOWSKI,  
Tadeusz [PL/PL]; Kosmonautow 13/38, PL-61-631 Poznan (PL).
- (74) Agent: KOLSTER OY AB; Iso Roobertinkatu 23,  
P.O.Box 148, FI-00121 Helsinki (FI).
- (81) Designated States (unless otherwise indicated, for every kind of national protection available): AE, AG, AL, AM, AT, AU, AZ, BA, BB, BG, BH, BR, BW, BY, BZ, CA, CH, CN, CO, CR, CU, CZ, DE, DK, DM, DO, DZ, EC, EE, EG, ES, FI, GB, GD, GE, GH, GM, GT, HN, HR, HU, ID, IL, IN, IS, JP, KE, KG, KM, KN, KP, KR, KZ, LA, LC, LK, LR, LS, LT, LU, LY, MA, MD, ME, MG, MK, MN, MW, MX, MY, MZ, NA, NG, NI, NO, NZ, OM, PG, PH, PL, PT, RO, RS, RU, SC, SD, SE, SG, SK, SL, SM, SV, SY, TJ, TM, TN, TR, TT, TZ, UA, UG, US, UZ, VC, VN, ZA, ZM, ZW.
- (84) Designated States (unless otherwise indicated, for every kind of regional protection available): ARIPO (BW, GH, GM, KE, LS, MW, MZ, NA, SD, SL, SZ, TZ, UG, ZM, ZW), Eurasian (AM, AZ, BY, KG, KZ, MD, RU, TJ, TM), European (AT, BE, BG, CH, CY, CZ, DE, DK, EE, ES, FI, FR, GB, GR, HU, IE, IS, IT, LT, LU, LV, MC, MT, NL, PL,

[Continued on next page]

(54) Title: INSULATED PANEL AND INTERLOCK MECHANISM THEREOF

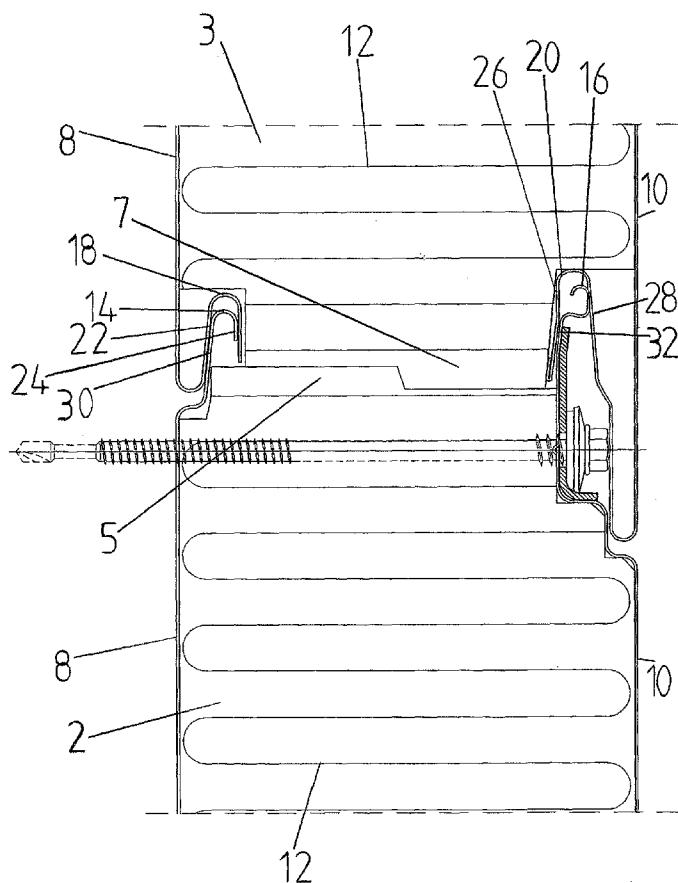

(57) Abstract: The invention relates to an interlock mechanism for insulated building panels (2, 3) and an insulated building panel (2, 3) having an interlocking mechanism, the interlock mechanism comprising one or more longitudinally extending tongue provided on a first side edge of a first panel (2), one or more longitudinally extending generally U-shaped or V-shaped or at least partially tapering shaped groove provided on a second side edge of the first panel (2), the tongues and grooves being arranged to be respectively joined with grooves and tongues of a like adjacently positioned second panel for interlocking the first panel (2) to a second panel (3). At least one tongue is provided with a resilient spring element deforming when received in the respective groove and generating a biasing force against the inner sidewalls of the groove through the deformation.

WO 2008/074926 A1



PT, RO, SE, SI, SK, TR), OAPI (BF, BJ, CF, CG, CI, CM,  
GA, GN, GQ, GW, ML, MR, NE, SN, TD, TG).

— *before the expiration of the time limit for amending the  
claims and to be republished in the event of receipt of  
amendments*

**Published:**

— *with international search report*

## INSULATED PANEL AND INTERLOCK MECHANISM THEREOF

### FIELD OF THE INVENTION

The present invention relates to insulated building panel according to the preamble of claim 1, and particularly to an insulated building panel having first and second side edges connectable to second and first side edges of a like adjacently positioned second panel respectively, the panel comprising: oppositely positioned first and second relatively thin metal sheets forming first and second side faces of the panel respectively, at least one of the said metal sheets further forming longitudinally extending first and second male side edge connectors on the first side edge of the panel and longitudinally extending first and second female side edge connectors on the second side edge of the panel, the male side edge connectors and female side edge connectors being arranged to be respectively joined with female and male side edge connectors of a like adjacently positioned second panel for interlocking the panel to a second panel; and central core insulating material arranged between the first and second metal sheet. The present invention relates also to a interlock mechanism for an insulated building panel according to the preamble of claim 24, and particularly to an interlock mechanism for insulated building panels, the interlock mechanism comprising one or more longitudinally extending tongue provided on a first side edge of a first panel, one or more longitudinally extending generally U-shaped or V-shaped or at least partially tapering shaped groove provided on a second side edge of the first panel, the tongues and grooves being arranged to be respectively joined with grooves and tongues of a like adjacently positioned second panel for interlocking the first panel to a second panel.

### BACKGROUND OF THE INVENTION

Insulated building panels having two oppositely positioned thin metal sheets forming the side faces of the panel and a central core insulating material provided between the metal sheets. This kind of insulated panels are joined together from side edges with interlock, tongue-and-groove or butment joints. These joints have usually one, two or possibly more respectively interlocking female and male connector elements. Accordingly the male connector elements extend along the first side edge of the panel, preferably along the entire length of the first side edge, and female side edge connector elements

extend along the second side edge of panel, preferably along the entire length of the second side edge. Each panel is therefore configured to be joined with a like adjacent second panel such that the male connector elements on the first side edge of a panel interlock with the female connector elements on the second side edge of a like adjacent second panel.

One of the problems with the prior art joints between two adjacent panels is that the female and male connectors do not provide a tight joint that would prevent moisture, gases and heat from passing through the joint from one side of the panel to the other side of the panel or inside the panel. Another disadvantage of the prior art is that in a case of fire the prior art joints tend to open damaging the panels and therefore structures consisting of several panels and the fire may spread to bearing structures and other parts of a building. This endangers safety of the building such that fire gases may pass through the joints of the panels and the fire may spread and hazardous gases will convey to possible other parts of a building.

Furthermore, for providing tight joints between two adjacent panels the female connector are in many cases provide with a sealing element that is mounted on the bottom of the female connector such that the sealing element is compressed between the bottom of the female connector and front end of the male connector. This sealing element seals the joint preventing moisture, heat and gases from passing through the joint from one side of the panel to the other side of the panel.

One of the problems associated with these joints is that the sealing element usually tends to escape, move or slip away from the bottom of the female connector when building panels are mounted and joined together and further removed from each other and from the abutment to each other. This escaping of the sealing element may also happen due to thermal deformations of the panels or the metal sheets of the panels. Typically the sealing element tends to move away from the joint causing the sealing of the joint to weaken. This is especially the case when adjacent together joined panels has to be disengaged from each other, the sealing element tends to drop or move away from the bottom of the female connector. Therefore the sealing element may be absent when the building panels are mounted together again. This weakening of the sealing of the joint endangers safety of the building such that fire gases may pass through the joints of the panels and the fire may spread and hazardous gases will convey to possible other parts of a building. Also mois-

ture may pass through the joints to other part of the building and inside the building panel.

#### BRIEF DESCRIPTION OF THE INVENTION

5           An object of the present invention is to provide an insulated building panel and an interlock mechanism thereof so as to overcome the above disadvantages. The objects of the invention are achieved by an insulated building panel that is characterized in that the at first and/or second of the female side edge connectors are formed to have a substantially uniform width or at least  
10 partially tapering profile towards the bottom of the female side edge connector, and that the first and/or second male side edge connectors, respectively, are formed to deform resiliently when received in the respective female side edge connector for generating a biasing force against the female side edge connector. The objects of the invention are further achieved by an interlock mechanism that is characterized in that the at least one tongue is provided with a resilient spring element deforming when received in the respective groove and  
15 generating a biasing force against the inner sidewalls of the groove through the deformation.

20           The preferred embodiments of the invention are disclosed in the dependent claims.

25           The invention is based on the idea of providing a insulated panel having two oppositely arranged thin metal sheets and a central core insulating material between the metal sheets with an interlock mechanism having male and female, or groove and tongue, connectors provided on the side edges of  
30 the building panel. The male connectors or some of the male connectors extend longitudinally preferably and generally along the whole length of the side edge of a panel, and they are formed such that they compress or deform resiliently as they are installed into the respective female connectors. The male and female connectors are formed such that the male connector biases and/or  
35 provides a force against the sidewalls on the generally groove shaped female connector. The female connectors are formed such that they have a uniform or tapering width from the open upper part of the groove towards the bottom of the groove. Therefore the male connectors are formed such that they compress or deform biasing against the sidewalls of the female connector transverse to the longitudinal direction of the female connector. This biasing force is

applied to the female connector preferably along the whole length of the female connector and along the entire length of the side edge of the panel.

An advantage present invention is that it produces a force that seals tightly the joints between two adjacent panels and prevents or the joint from opening in a case of fire as well provides an easy interlocking of two adjacent panels. The panel and interlock mechanism of the panel therefore provides a strong seal between the adjacent panels without any additional gaskets, sealing materials or locking members. Thus the invention enhances the structural characteristics as well as the sealing properties of an insulated building panel.

#### 10 BRIEF DESCRIPTION OF THE DRAWINGS

In the following the invention will be described in greater detail by means of preferred embodiments with reference to the attached drawing, in which

Figure 1 is schematic view building panels and the interlock mechanism thereof according to the present invention;

Figures 2A and 2B show partial cross section of a building panel according to one embodiment of the present invention; and

Figure 3 shows an interlock mechanism for a building panel according to one embodiment of the present invention.

20

#### DETAILED DESCRIPTION OF THE INVENTION

Figure 1 shows a section of two adjacent interlocked building panels 2, 3. The building panels 2, 3 comprise a first and second oppositely positioned first and second relatively thin metal sheets 8, 10 forming first and second side faces of the panels 2, 3 respectively. Between the metal sheets 8, 10 is provided a central core insulating material 12 that may be attached to the metal sheets 8, 10 for example by gluing or some other way. The insulating material 12 may be any possible material that provides sufficient insulation and structural rigidity for the panel 2, 3. Each panel 2, 3 have also first and second side edges 5, 7, which are provided with male and female side edge connectors, respectively. In use these the side edges 5 and 7 extend generally horizontally. It should be noted that the panels comprise also third and fourth side edges, which in use extend generally vertically. Also the third and fourth side edges may be provided with male and female side edge connectors of the same type as the first and second side edges, if desired.

35

According to the state of the art male and female side edge connectors are provided by forming, bending or the like the metal sheets 8 and 10. This forming may be accomplished by making the metal sheets 8, 10 extend over the insulating material 12 in the edge region of the panel 2, 3 and roll forming the edge regions of the metal sheets 8, 10 such that the metal sheets 8, 10 at the first side edge 5 of the panel 2, 3 generate one or more male side edge connectors 14, 16 projecting first side edge 5 of the panel 2, 3, and that the metal sheets 8, 10 at the second side edge 7 of the panel 2, 3 generate one or more female side edge connectors 18, 20 configured to receive the respective male side edge connectors 14, 16, as shown in figure 1. The male side edge connectors 14, 16 and female side edge connectors 18, 20 are arranged to extend preferably along the entire side edges 5, 7 of the panel 2, 3, respectively, to provide a joint between to adjacently positioned like panels 2, 3.

However, it should be noted that the panel 2, 3 may also be provided such that the metal sheets 8, 10 form one, two, three or even more respective male and female side edge connectors on the respective side edges 5, 7 a panel 2, 3. Furthermore, it should be noted that also separate means may be installed or attached to the panels 2, 3 for providing an interlock mechanism to the side edges of the panels 2, 3. In the embodiment shown in figure 1, interlock mechanism, and therefore the male and female side edge connectors 14, 16, 18, 20 are provided by forming the metal sheets 8, 10.

As shown in figure 1, the female side edge connectors 18, 20 are formed as grooves that extend longitudinally along the second side edge 7 of the panel 3. The grooves 18, 20 tapering cross section or profile towards the bottom of the groove transversely to the longitudinal direction of the groove 18, 20. The cross section of the grooves 18, 20 may be also be generally U-shaped such that the width of the groove 18, 20 remains generally constant towards the bottom of the groove 18, 20. The grooves 18, 20 may also have partially tapering cross section such that the only on part of the cross section has a tapering profile whilst the other parts of the groove have generally constant width. In figure 1 the female side edge connectors 18, 20 are formed by bending the metal sheets 8, 10 first towards the centre of the panel 3 and then back towards the second side edge 7 of the panel 7. Thus the metal sheets 8, 10 form the sidewalls 22, 24 and 26, 28 of the grooves 18 and 20, respectively, as well as the bottom of the grooves 18, 20. The grooves that receive male

side edge connectors and/or tongues are formed to have a tapering, U-shaped, V-shaped or the like profile without any narrow necks or waists such that the installation of two panels together is easy and that joined panel may also be easily released from each other.

5 As shown in figure 1 that sidewalls 22, 24 and 26, 28 of the grooves 18 and 20 respectively do not have to be formed symmetrically, but the sidewalls of a groove may have a different tapering, bending and forming characteristics in the cross section profile.

10 According to the invention and figure 1, the first side edge 5 of a panel 2, 3 is provided with male side edge connectors 14, 16 configured to be received in the female side edge connectors 18, 20. The male side edge connectors are formed as tongues extending longitudinally along the first side edge 5 of the panel 2. The tongues 14, 16 are arranged to project from the first side edge 5 such that they may be inserted into the respective grooves 18, 20  
15 on the second side edge 7 of a like adjacently positioned panel 3. The tongues 14, 16 are formed to have curved, hook like, J-shaped, S-shaped, Z-shaped, zigzag shaped, reversed U-shaped or the like cross section transversely to the longitudinal direction of the grooves 18, 20. The tongue 14, 16 is formed such that it may compress or deform resiliently when installed in the respective  
20 groove 18, 20. The resilient compression or deformation biases the tongue 14, 16 against the sidewalls 22, 24 and/or 26, 28 of the respective grooves and then the tongue 14, 16 applies a force against the sidewalls of the groove.

To achieve the deformation or compression and biasing of the tongue 14, 16, the tongue should have a width transversely to the longitudinal  
25 direction of the grooves 18, 20 greater than the corresponding width of the grooves 18, 20. Then the sidewalls 22, 24 and/or 26, 28 of the groove compress the tongue 14, 16 as it is inserted into the groove 18, 20. In other words at least a part of the groove 18, 20 has a width that is smaller than a width of at least a part of a tongue 14, 16 that is inserted into the groove 18, 20. This may  
30 be accomplished by forming the groove 18, 20 to have a tapering profile towards the bottom of the groove 18, 20 and/or by forming the tongue 14, 16 to have a tapering profile towards the tip of the tongue 14, 16. In this way the biasing force of the tongue 14, 16 increases continuously as the tongue 14, 16 moves deeper into the groove 18, 20 and the biasing force against the inner  
35 sidewalls 22, 24, and/or 26, 28 of the groove remains when the tongue 14, 16 is in its position in the grooves 18, 20. It is enough that a part of the groove 18,



20 has a smaller width than a part of the tongue 14, 16 in the transverse direction to the groove. It should be noted that the grooves 18, 20 and the tongues have preferably a uniform shape in the longitudinal direction of the groove 18, 20 and the tongue 14, 16.

5           The tongue 14, 16 may be arranged to deform or compress such that it generates a biasing force in the transverse direction of the first and second side faces of the panel 2, 3 and/or against the inner sidewalls 22, 24, 26, 28 of the respective groove 18, 20. The tongue 14, 16 is also shaped such that it biases against the both inner sidewalls 22, 24 and/or 26, 28 of the groove 18, 20, respectively, in at least one contact point and/or area in a sidewall 22, 24, 26, 28. The tongue 14, 16 and groove 18, 20 may also be formed such that at least one sidewall 30, 32 of the tongue 14, 16 is pressed against a sidewall 22, 26 of the groove 18, 20 to form a longitudinally extending contact area when the tongue 14, 16 is received in the groove 18, 20. If the tongue 14, 16 has a S-shaped, Z-shaped, zigzag shaped or the like profile in the transverse direction to the longitudinally extending groove 18, 20, the tongue 14, 16 may bias against both inner sidewalls 22, 24, 26, 28 of the groove (18, 20) in at least two or more contact points/areas.

20           The grooves 18, 20 and the tongues 14, 16 extend respectively along the entire length of first and second side edges 5, 7 of the panel 2, 3 such that the tongue 14, 16 or part of it biases against the sidewalls 22, 24, 26, 28 of the groove 18, 20 along the entire length of the side edge 5, 7 of the panel 2, 3. This is advantageous since the biasing force seals the joint between two adjacent panels 2, 3 against moisture and heat. Additionally the biasing force prevents the grooves 18, 20 and tongues 14, 16 from deforming disadvantageously in a case of fire, when the metal sheets 8, 10 tend to bend due to the high temperature such that the joint between the panels 2, 3 opens. This way the opening of the joint may be prevented longer or delayed without additional equipment or parts and still conserve the easy installation of the panels 2, 3 together.

30           In use building panel 2, 3 normally is arranged such that the female groove 18, 20 of a second panel 3 opens downwards to receive the upwards extending tongue 14, 16 of the first panel 2 below the second panel 3.

35           Furthermore, the tongue 14, 16 may be provided with a resilient element deforming when received in the respective groove 18, 20 and generating a biasing force against the inner sidewalls 22, 24, 26, 28 of the groove 18,

20 through the deformation. The resilient element may be a separate part attached or provided to the tongue 14, 16 or it may be part of the tongue 14, 16. The tongue 14, 16, part thereof or the resilient element forms a spring like element arranged to bias against inner sidewalls 22, 24, 26, 28 of the female side edge connector 18, 20. Further, the groove may be provided by separate groove means such that the groove is separate part attached or installed to the second side edge 7 of the panel 2, 3.

From the above it is evident that in the present invention the panels 2, 3 or the interlock mechanism according to the invention may comprise one or more tongue-groove, male-female or abutment joints as described. Additionally, the shape, dimensions and other configurations of the tongues and grooves may differ from what is described without departing from the scope of the present invention.

Figure 2A is shows a section of a building panel 2 comprise a first and second oppositely positioned first and second relatively thin metal sheets 8, 10 forming first and second side faces of the panel 2. Between the metal sheets 8, 10 is provided a central core insulating material 12 that may be attached to the metal sheets 8, 10 for example by gluing or some other way. The insulating material 12 may be any possible material that provides sufficient insulation and structural rigidity for the panel 2. The panel 2 has also first and second side edges 5, 7 (figure 2B), which are provided with male and female side edge connectors 14, 18, 20, respectively. In use these the side edges 5 and 7 extend generally horizontally. It should be noted that the panels comprise also third and fourth side edges, which in use extend generally vertically. Also the third and fourth side edges may be provided with male and female side edge connectors of the same type as the first and second side edges, if desired.

According to the state of the art male and female side edge connectors 14, 18, 20 are provided by forming, bending or the like the metal sheets 8 and 10. This forming may be accomplished by making the metal sheets 8, 10 extend over the insulating material 12 in the edge region of the panel 2, 3 and roll forming the edge regions of the metal sheets 8, 10 such that the metal sheets 8, 10 at the first side edge 5 of the panel 2 generate one or more male side edge connectors 14 projecting from first side edge 5 of the panel 2, and that the metal sheets 8, 10 at the second side edge 7 of the panel 2, 3 generate one or more female side edge connectors 18, 20 configured to receive the

respective male side edge connectors 14, as shown in figure 2B. The male side edge connectors 14 and female side edge connectors 18, 20 are arranged to extend preferably along the entire side edges 5, 7 of the panel 2, respectively, to provide a joint between two adjacently positioned like panels 2, 3.

However, it should be noted that the panel 2 may also be provided such that the metal sheets 8, 10 form one, two, three or even more respective male and female side edge connectors 14, 18, 20 on the respective side edges 5, 7 a panel 2. Furthermore, it should be noted that also separate means may be installed or attached to the panel 2 for providing an interlock mechanism to the side edges of the panel 2. In the embodiment shown in figure 2A and 2B, interlock mechanism, and therefore the male and female side edge connectors 14, 18, 20 are provided by forming the metal sheets 8, 10.

As shown in figure 2A, the female side edge connectors 18, 20 are formed as grooves that extend longitudinally along the second side edge 7 of the panel 2. According to prior art the grooves 18, 20 have tapering cross section or profile towards the bottom of the groove transversely to the longitudinal direction of the groove 18, 20. Other possibilities for the cross section of the grooves 18, 20 have been generally U-shaped such that the width of the groove 18, 20 remains generally constant towards the bottom of the groove 18, 20. In figure 3 the female side edge connectors 18, 20 are formed by bending the metal sheets 8, 10 first towards the centre of the panel 2 and then back towards the second side edge 7 of the panel 2. The grooves that receive male side edge connectors and/or tongues may be formed to have a tapering, U-shaped, V-shaped or the like profile such that the installation of two panels together is easy and that joined panel may also be easily released from each other.

As shown in figures 2A and 2B, the bottom 40 of a groove or female side edge connector 18, 20 may be in some cases provided with a sealing element 50. The sealing element 50 may be a sealing strip, extrudable sealing mass, adhesive mass or the like that may be attached to the bottom 40 of the groove 18, 20. Such as polyurethane may be used as material for the sealing element 30. When two adjacent panels 2 and 3 are joined together the sealing element 30 is compressed between or is in contact with the bottom of the groove 18, 20 and the upper end of the tongue 14, as shown in figure 2B. This way the joint between the tongue 14 and the groove 18, 20 may be sealed

such that heat, moisture, gases or fire cannot pass through the joint from one side of the panels 2, 3 to the other. During the installation of two adjacent panels 2, 3 together and after the installation as well as when the joint between the panels 2, 3 has to be opened temporarily or for later reinstallation of the panel or panels 2, 3, the sealing element 50 tends to move away from the bottom of the groove 18, 20. Thus the seal between tongue 14 and grooves 18, 20 is endangered or weakened as the sealing element 50 is not in correct place.

According to the present invention, the female side edge connector or groove 18, 20 receiving the sealing element 50 is provided with at the bottom or close to the bottom with an expansion 52 for increasing the width of the groove 18, 20 locally at the bottom or in vicinity of the bottom of the groove 18, 20. One embodiment of this expansion or expansion chamber 52 is shown in all figures 2A, 2B and 3.

The result is accordingly achieved, when biasing force and the extension for the sealing element are used in a same insulated panel and specifically in the same interlock mechanism.

It will be obvious to a person skilled in the art that, as the technology advances, the inventive concept can be implemented in various ways. The invention and its embodiments are not limited to the examples described above but may vary within the scope of the claims.

## CLAIMS

1. An insulated building panel (2) having first and second side edges (5, 7) connectable to second and first side edges (5, 7) of a like adjacently positioned second panel (3) respectively, the panel (2) comprising:

5 oppositely positioned first and second relatively thin metal sheets (8, 10) forming first and second side faces of the panel (2) respectively, at least one of the said metal sheets (8, 10) further forming longitudinally extending first and second male side edge connectors (14, 16) on the first side edge (5) of the panel (2) and longitudinally extending first and second female side edge connectors (18, 20) on the second side edge (7) of the panel (2), the male side edge connectors (14, 16) and female side edge connectors (18, 20) being arranged to be respectively joined with female and male side edge connectors (14, 16, 18, 20) of a like adjacently positioned second panel (3) for interlocking the panel (2) to a second panel (3); and

15 central core insulating material (12) arranged between the first and second metal sheet (8, 10),

**characterized** in that the at first and/or second of the female side edge connectors (18, 20) are formed to have a substantially uniform width or at least partially tapering profile towards the bottom of the female side edge connector (18, 20), and that the first and/or second male side edge connectors (14, 16), respectively, are formed to deform resiliently when received in the respective female side edge connector (18, 20) for generating a biasing force against the female side edge connector (18, 20).

2. An insulated building panel (2) according to claim 1, **characterized** in that male side edge connector (14, 16) is arranged to deform such that it generates a biasing force in the transverse direction of the first and second side faces of the panel (2).

3. An insulated building panel (2) according to claim 1 or 2, **characterized** in that male side edge connector (14, 16) is arranged to deform such that it generates a biasing force against the inner sidewalls (22, 24, 26, 28) of the respective female side edge connector (18, 20).

4. An insulated building panel (2) according any one of t claims 1 - 3, **characterized** in that male side edge connector (14, 16) is shaped such that it biases against the both inner sidewalls (22, 24, 26, 28) of the female side edge connector (18, 20) in at least one contact points and/or areas.

5. An insulated building panel (2) according any one of claims 1 - 4, **characterized** in that the male side edge connector (14, 16) has at least one sidewall (30, 32) that is pressed against an inner sidewall (22, 24, 26, 28) of the female side edge connector (18, 20) to form a longitudinally extending contact area when the male side edge connector (14, 16) is received in the female side edge connector (18, 20).

6. An insulated building panel (2) according any one of claims 1 - 5, **characterized** in that male side edge connector (14, 16) and the female side edge connector (18, 20) are formed such that male side edge connector (14, 16) has at least partially greater width transversely to the longitudinal direction of the female side edge connector (18, 20) than at least a part of the female side edge connector (18, 20).

7. An insulated building panel (2) according any one of claims 1 - 6, **characterized** in that also the male side edge connector (14, 16) has at least partially tapering shape towards the tip area of the male side edge connector (14, 16).

8. An insulated building panel (2) according any one of claims 1 - 7, **characterized** in that the male side edge connector (14, 16) has a curved, U-shaped, J-shaped or the like profile in the transverse direction to the longitudinally extending female side edge connector (18, 20) such that the male side edge connector (14, 16) biases against both inner sidewalls (22, 24, 26, 28) of the female side edge connector (18, 20).

9. An insulated building panel (2) according any one of claims 1 - 7, **characterized** in that male side edge connector (14, 16) has a S-shaped, Z-shaped, zigzag shaped or the like profile in the transverse direction to the longitudinally extending female side edge connector (18, 20) such that the male side edge connector (14, 16) biases against both inner sidewalls (22, 24, 26, 28) of the female side edge connector (18, 20) in at least one contact point/area.

10. An insulated building panel (2) according any one of claims 1 - 9, **characterized** in that the male and female side edge connectors (14, 16; 18, 20) extend respectively along the entire length of first and second side edges (5, 7) of the panel (2).

11. An insulated building panel (2) according any one of claims 1 - 10, **characterized** in that building panel (2) is arranged such that in use the female side edge connector (18, 20) of the second panel (3) opens down-

wards to receive the upwards extending male side edge connector (14, 16) of the first panel (2).

12. An insulated building panel (2) according any one of claims 1 - 11, **characterized** in that the male side edge connector (14, 16) or part thereof forms a spring like element arranged to bias against inner sidewalls (22, 24, 26, 28) of the female side edge connector (18, 20).

13. An insulated building panel (2) according any one of claims 1 - 11, **characterized** in that a sealing element or elements (50) arranged at the bottom (40) of at least one of the female connectors (18, 20) for sealing the joint between the corresponding male (14) and female (18, 20) side edge connectors.

14. An insulated building panel (2) according to claim 13, **characterized** in that least one of the female side edge connectors (18, 20) is provided at the bottom (40) or close vicinity of the bottom (40) with at least one expansion (52) extending along the female side edge connector (18, 20) for receiving at least part of the sealing element (30).

15. An insulated building panel (2) according to claim 14, **characterized** in that the expansion (52) is arranged to project in the transverse direction of the longitudinally extending female side edge connector (18, 20).

16. An insulated building panel (2) according to one of claims 14 or 15, **characterized** in that the expansion (52) is arranged to project in the width direction of the female side edge connector (18, 20).

17. An insulated building panel (2) according to one of claims 14 to 16, **characterized** in that the expansion (52) is arranged to project towards the first or second side face of the panel (2).

18. An insulated building panel (2) according to one of claims 14 to 16, **characterized** in that at least one of the female side edge connectors (18, 20) is provided with two expansions (52) projecting in opposed directions in the width direction of the female side edge connector (18, 20).

19. An insulated building panel (2) according to one of claims 14 to 16, **characterized** in that at least one of the female side edge connectors (18, 20) is provided at the bottom (40) with an expansion (52) projecting towards the first and second side face of the panel (2).

20. An insulated building panel (2) according to claim 18 or 19, **characterized** in that the expansion(s) (52) are arranged to project

symmetrically or asymmetrically in the width direction of the female side edge connector (18, 20).

21. An insulated building panel (2) according to claim 18, **characterized** in that the expansions (52) have identical or different dimensions and shape.

22. An insulated building panel (2) according to one of claims 14 to 21, **characterized** in that the expansion(s) (52) have generally circular or curved shape.

23. An insulated building panel (2) according to one of claims 14 to 22, **characterized** in that the expansion(s) (52) are arranged to provide a neck (34) into the female side edge connector (18, 20) for reducing the width of the female side edge (18, 20) connector locally.

24. An interlock mechanism for insulated building panels (2, 3), the interlock mechanism comprising one or more longitudinally extending tongue (14, 16) provided on a first side edge (5) of a first panel (2), one or more longitudinally extending generally U-shaped or V-shaped or at least partially tapering shaped groove (18, 20) provided on a second side edge (7) of the first panel (2), the tongues (14, 16) and grooves (18, 20) being arranged to be respectively joined with grooves (18, 20) and tongues (16, 18) of a like adjacently positioned second panel (3) for interlocking the first panel (2) to a second panel (3), **characterized** in that the at least one tongue (14, 16) is provided with a resilient spring element deforming when received in the respective groove (18, 20) and generating a biasing force against the inner sidewalls (22, 24, 26, 28) of the groove (18, 20) through the deformation.

25. An interlock mechanism according to claim 24, **characterized** in that building panel (2) comprises oppositely positioned first and second relatively thin metal sheets (8, 10) forming first and second side faces of the panel (2) respectively, and central core insulating material (12) arranged between the first and second metal sheet (8, 10).

26. An interlock mechanism according to claim 25, **characterized** in that one or more of the grooves (18, 20) and/or one or more of the tongues (14, 16) are provided by forming the metal sheets (8, 10).

27. An interlock mechanism according to any one of the claims 24 - 26, **characterized** in that the tongue (14, 16) or an integral part of the tongue (14, 16) forms the resilient element.

28. An interlock mechanism according to any one of the claims 24 -



27, **characterized** in that resilient element is arranged to deform such that it generates a biasing force against the inner sidewalls (22, 24, 26, 28) of the groove (18, 20) in the transverse direction of the first and second side faces of the panel (2).

5           29. An interlock mechanism according to any on of the claims 24 - 28, **characterized** in that resilient element is shaped such that it biases against the both inner sidewalls (22, 24, 26, 28) of the groove (18, 20) in at least one contact point and/or area.

10           30. An interlock mechanism according to any on of the claims 24 - 29, **characterized** in that resilient element comprises at least one sidewall (30, 32) that is pressed against an inner sidewall (22, 26) of the groove (18, 20) to form a longitudinally extending contact area when the resilient element is received in the groove (18, 20).

15           31. An interlock mechanism according to any on of the claims 24 - 30, **characterized** in that the resilient element and the groove (18, 20) are formed such that the resilient element has a greater width transversely to the longitudinal direction of the groove (18, 20) than at least the bottom area of the groove (18, 20) for compressing the resilient element when received in the groove.

20           32. An interlock mechanism according to any on of the claims 24 - 31, **characterized** in that also the resilient element has at least partially tapering shape towards the tip area of the tongue (14, 16) in the transverse direction of the groove (18, 20).

25           33. An interlock mechanism according to any on of the claims 24 - 32, **characterized** in that the resilient element has a curved, substantially U-shaped, J-shaped, or the like profile in the transverse direction to the longitudinally extending groove (18, 20) such that the resilient element biases against both inner sidewalls (22, 24, 26, 28) of the groove (18, 20).

30           34. An interlock mechanism according to any on of the claims 24 - 32, **characterized** in that the resilient element has a S-shaped, Z-shaped, zigzag shaped or the like profile in the transverse direction to the longitudinally extending groove (18, 20) such that the tongue (14, 16) biases against both inner sidewalls (22, 24, 26, 28) of the groove (14, 16) in at least one contact point/area.

35           35. An interlock mechanism according to any on of the claims 24 - 34, **characterized** in that the resilient element and the groove (18, 20)

extend respectively along the entire length of first and second side edges (5, 7) of the panel (2, 3).

36. An interlock mechanism according to any one of the claims 24 - 35, **characterized** in that in use the groove (18, 20) of the second panel (3) is arranged to open downwards for receiving the upwards extending resilient element of the first panel (2).

37. An interlock mechanism according to any one of the claims 24 - 35, **characterized** in that least one of the grooves (18, 20) is provided between the bottom (40) and the open upper part (42) with a neck (34) for reducing the width of the groove (18, 20) locally.

38. An interlock mechanism according to claim 37, **characterized** in that the width of the groove (18, 20) is greater at the bottom (40) of the groove (18, 20) than at the neck (34).

39. An interlock mechanism according to claim 37 or 38, **characterized** in that the width of the groove (18, 20) is greater at the bottom (40) of the groove (18, 20) and at the upper part (42) of the groove (18, 20) than at the neck (34).

40. An interlock mechanism according to any of claims 37 - 39, **characterized** in that the neck (34) is provided by bending the first or second sidewall (44, 46) locally towards the other of the second or first sidewalls (44, 46).

41. An interlock mechanism according to any of claims 37 - 39, **characterized** in that the neck (34) is provided by bending the first and second sidewalls (44, 46) locally towards each other.

42. An interlock mechanism according to any of claims 37 - 41, **characterized** in that groove (18, 20) is further provided with at least one expansion chamber (52) on the bottom side of the neck (34), the at least one expansion chamber (52) extending along the groove (18, 20) and projecting in the width direction of the groove (18, 20) for increasing the width of the groove (18, 20).

43. An interlock mechanism according to claim 42, **characterized** in that expansion chamber (52) is provided by bending the first or second sidewall (44, 46) of the groove (18, 20) away from the second or first sidewall (44, 46) respectively.

44. An interlock mechanism according to claim 42, **characterized** in that the expansion chamber (52) is provided on the first and second

sidewall (44, 46) by bending the first and second sidewall (44, 46) of the groove (18, 20) away from each other.

45. An interlock mechanism according to claim 42 or 44, **characterized** in that the expansion chamber (52) is provided by bending first  
5 and second sidewalls (44, 46) of the groove (18, 20) symmetrically or asymmetrically.

1/3

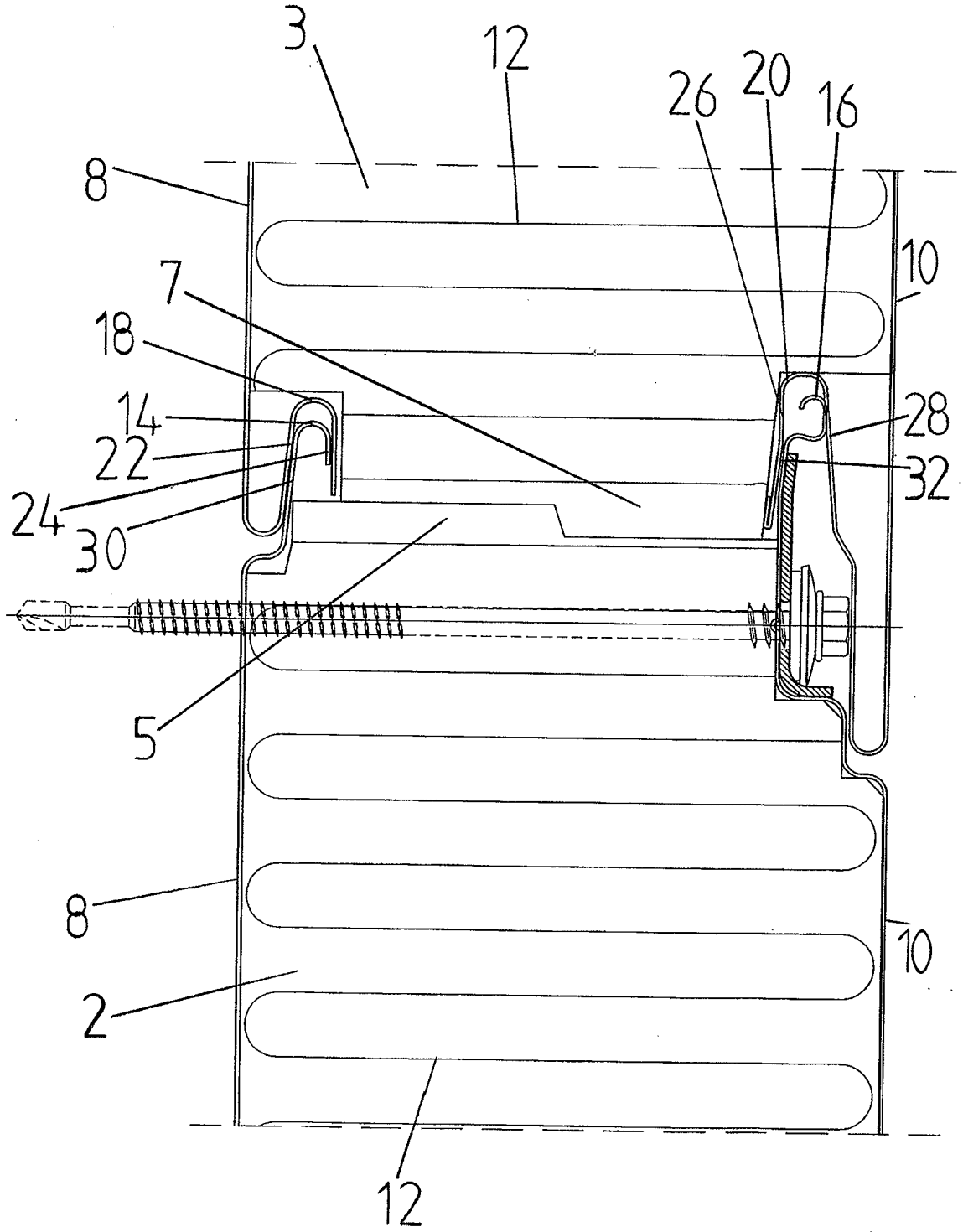
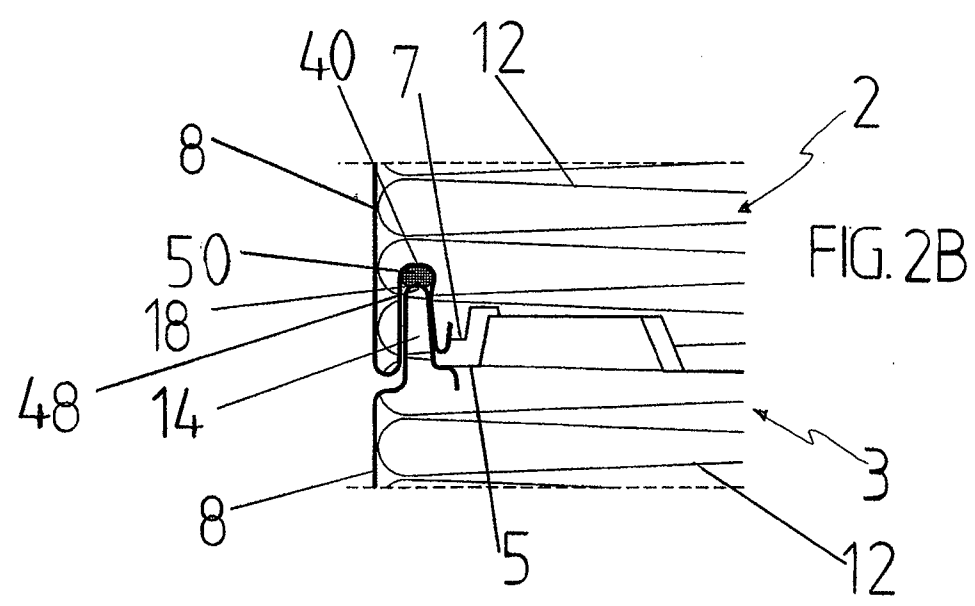
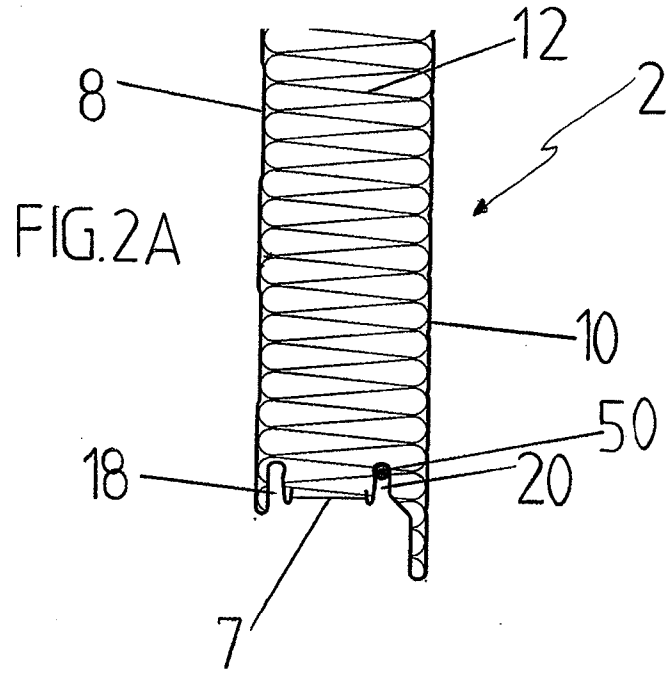

FIG.1

2/3



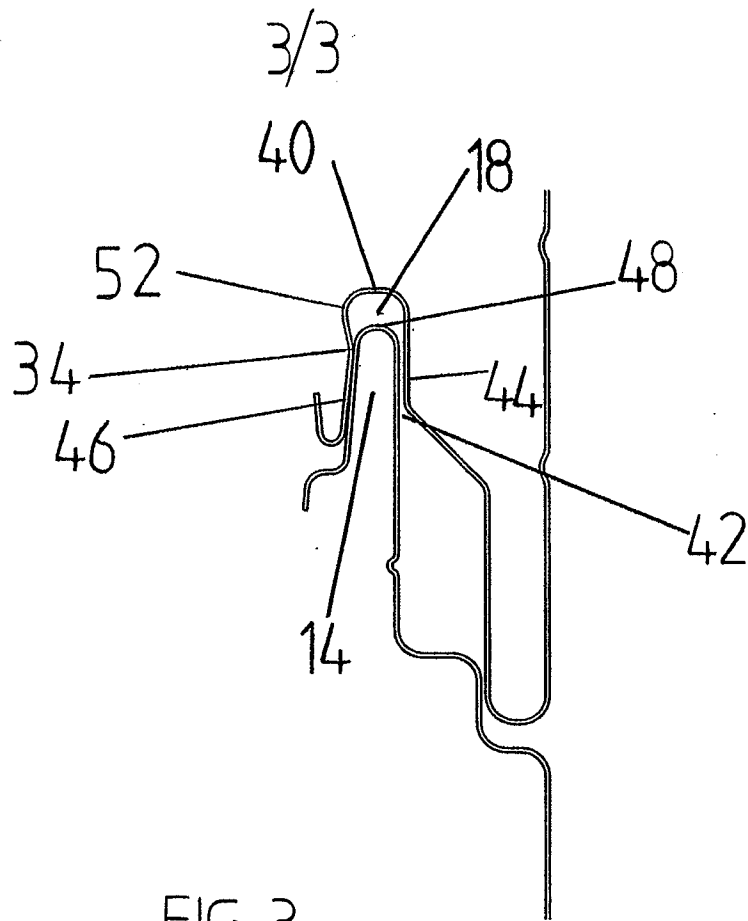

FIG. 3

## INTERNATIONAL SEARCH REPORT

International application No.

PCT/FI2007/050713

A. CLASSIFICATION OF SUBJECT MATTER See extra sheet According to International Patent Classification (IPC) or to both national classification and IPC		
B. FIELDS SEARCHED Minimum documentation searched (classification system followed by classification symbols) IPC 8: E04C, E04B, E04F Documentation searched other than minimum documentation to the extent that such documents are included in the fields searched FI, SE, NO, DK Electronic data base consulted during the international search (name of data base and, where practicable, search terms used) EPO-internal, WPI		
C. DOCUMENTS CONSIDERED TO BE RELEVANT		
Category*	Citation of document, with indication, where appropriate, of the relevant passages	Relevant to claim No.
X	WO 0177457 A1 (TRIMO D D et al.) 18 October 2001 (18.10.2001) whole document, specifically pages 4 and 5, figures 1 and 2	1, 10-11, 24-26, 35-36
Y		2-9, 12-23, 27-34, 37-45
Y	US 5293728 A (CHRISTOPHER MICHAEL E et al.) 15 March 1994 (15.03.1994), whole document, specifically column 4, lines 47-54, column 6, lines 20-29, figures 1-4	2-9, 12, 27-34
Y	US 5448865 A (PALMERSTEN MICHAEL J) 12 September 1995 (12.09.1995), whole document, specifically column 4, lines 22-25, column 5, lines 8-18, figures 1-17	2-9, 12, 27-34
Y	US 5247770 A (TING RAYMOND M L) 28 September 1993 (28.09.1993), whole document, specifically column 4, lines 1-32, column 4, lines 50-55, figures 3 and 4	2-9, 12, 27-34
<input checked="" type="checkbox"/> Further documents are listed in the continuation of Box C. <input checked="" type="checkbox"/> See patent family annex.		
* Special categories of cited documents: "A" document defining the general state of the art which is not considered to be of particular relevance "E" earlier application or patent but published on or after the international filing date "L" document which may throw doubts on priority claim(s) or which is cited to establish the publication date of another citation or other special reason (as specified) "O" document referring to an oral disclosure, use, exhibition or other means "P" document published prior to the international filing date but later than the priority date claimed		"T" later document published after the international filing date or priority date and not in conflict with the application but cited to understand the principle or theory underlying the invention "X" document of particular relevance; the claimed invention cannot be considered novel or cannot be considered to involve an inventive step when the document is taken alone "Y" document of particular relevance; the claimed invention cannot be considered to involve an inventive step when the document is combined with one or more other such documents, such combination being obvious to a person skilled in the art "&" document member of the same patent family
Date of the actual completion of the international search 31 March 2008 (31.03.2008)		Date of mailing of the international search report 29 April 2008 (29.04.2008)
Name and mailing address of the ISA/FI National Board of Patents and Registration of Finland P.O. Box 1160, FI-00101 HELSINKI, Finland Facsimile No. +358 9 6939 5328		Authorized officer Janne Pirhonen Telephone No. +358 9 6939 500

## INTERNATIONAL SEARCH REPORT

International application No.

PCT/FI2007/050713

C (Continuation). DOCUMENTS CONSIDERED TO BE RELEVANT		
Category*	Citation of document, with indication, where appropriate, of the relevant passages	Relevant to claim No.
Y	FI 77294 B (HOESCH WERKE AG) 31 October 1988 (31.10.1988), abstract, figures	13-23, 37-45
Y	JP 8284373 A (IG TECH RES INC) 29 October 1996 (29.10.1996), abstract, figures	13-23, 37-45
Y	JP 2000017816 A (SHINKO KOGYO KK) 18 January 2000 (18.01.2000), abstract, figures	13-23, 37-45
Y	US 4122641 A (BARD JOHN A et al.) 31 October 1978 (31.10.1978), abstract, figures	13-23, 37-45
Y	DE 8108886 U1 (MICKELEIT EDUARD u. sohn) 20 August 1981 (20.08.1981), pages 4-6, figures 1-3	13-23, 37-45
Y	AT 364501 B (TABORSKY HANS ING) 27 October 1981 (27.10.1981), pages 3 and 4, figures 1-3	13-23, 37-45



**INTERNATIONAL SEARCH REPORT**  
**Information on patent family members**

International application No.  
PCT/FI2007/050713

Patent document cited in search report	Publication date	Patent family members(s)	Publication date
WO 0177457 A1	18/10/2001	EP 1290288 A1 DE 60103153D D1 AU 2421401 A AT 266131T T SI 20539 A	12/03/2003 09/06/2004 23/10/2001 15/05/2004 31/10/2001
US 5293728 A	15/03/1994	US 5410849 A	02/05/1995
US 5448865 A	12/09/1995	None	
US 5247770 A	28/09/1993	None	
FI 77294 B	31/10/1988	JP 60037363 A IT 1176354 B FR 2548245 A1 GB 2142670 A AT 81684 A AT 396272B B DE 3323778 A1	26/02/1985 18/08/1987 04/01/1985 23/01/1985 15/11/1992 26/07/1993 17/01/1985
JP 8284373 A	29/10/1996	None	
JP 2000017816 A	18/01/2000	None	
US 4122641 A	31/10/1978	CA 1066014 A1	13/11/1979
DE 8108886 U1	20/08/1981	None	
AT 364501 B	27/10/1981	AT 265580 A	15/03/1981

INTERNATIONAL SEARCH REPORT

International application No.  
PCT/FI2007/050713

CLASSIFICATION OF SUBJECT MATTER

Int.Cl.

**E04C 2/292** (2006.01)

**E04B 1/61** (2006.01)

*E04B 1/68* (2006.01)

*E04F 13/08* (2006.01)