



(72) HEINRICH, HANS-WILM, DE

(72) WOLF, MANFRED, DE

(72) SCHMIDT, DIETER, DE

(72) SCHLEINKOFER, UWE, DE

(71) KENNAMETAL INC., US

(51) Int.Cl.⁷ C22C 29/02

(30) 1997/08/27 (08/918,979) US

(54) **OUTIL ROTATIF DE PENETRATION DE COUCHE
TERRESTRE AVEC TREPAN RAPPORTE EN CERMET
CONTENANT UN LIANT CO-NI-FE**

(54) **A ROTARY EARTH STRATA PENETRATING TOOL WITH A
CERMET INSERT HAVING A CO-NI-FE-BINDER**

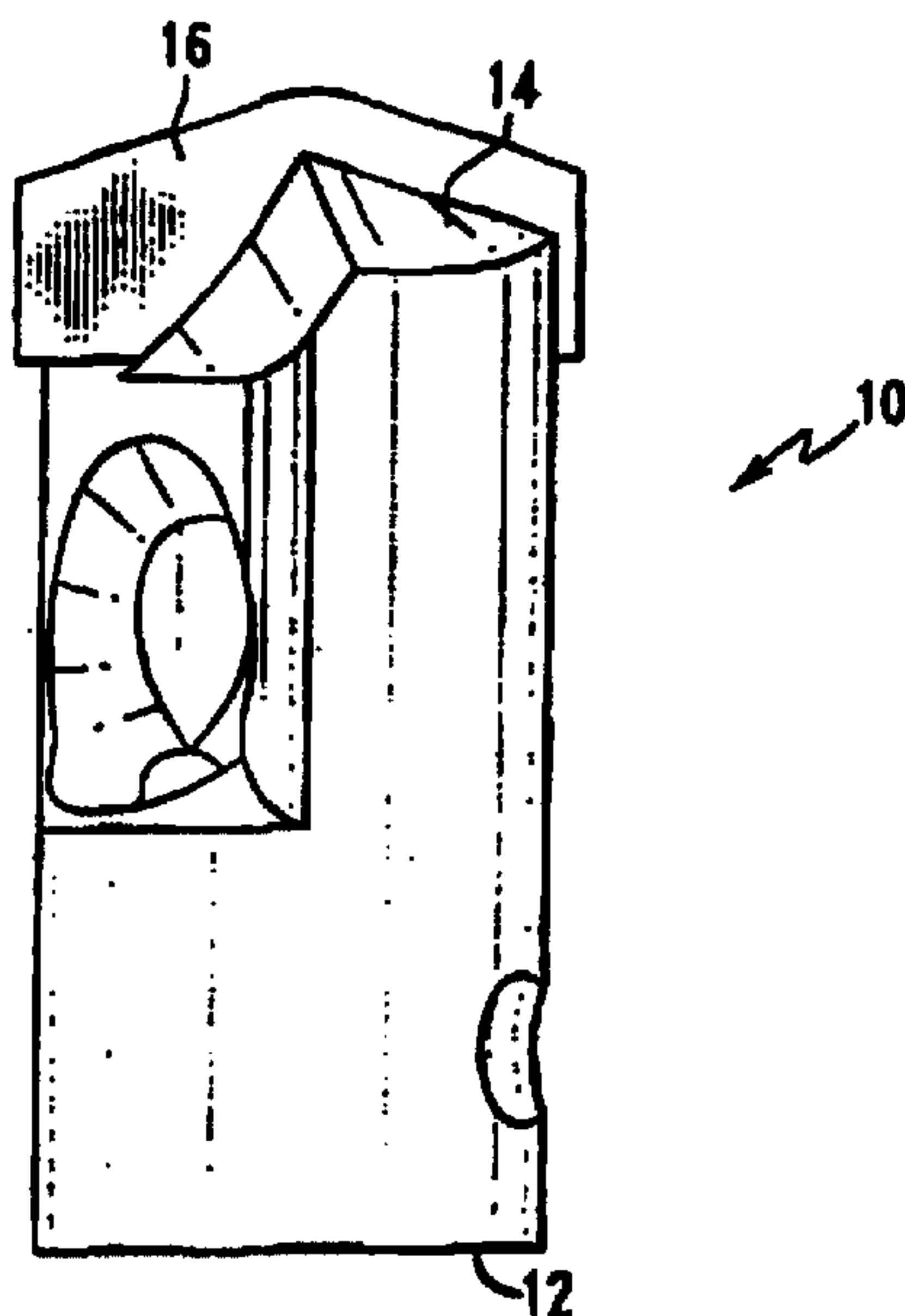

(57) Cet outil rotatif se compose d'un corps d'outil allongé et d'un trépan dur rapporté (16) fixé au corps de l'outil. Le trépan dur rapporté est fabriqué en cermet WC contenant du carbure du tungstène et environ 5 à 19 % en poids d'un liant Co-Ni-Fe. Le liant Co-Ni-Fe est unique en ce que, même soumis à des déformations plastiques, il conserve sensiblement intact son système cristallin cubique à faces centrées (fcc) et évite les transformations dues à l'effort et/ou aux contraintes.

(57) A rotary tool that includes an elongate tool body and a hard insert (16) affixed to the tool body is disclosed. The hard insert comprises a WC-cermet comprising tungsten carbide and about 5 wt.% to 19 wt.% Co-Ni-Fe-binder. The Co-Ni-Fe-binder is unique in that even when subjected to plastic deformation, the binder substantially maintains its face centered cubic (fcc) crystal structure and avoids stress and/or strain induced transformations.



PCT

WORLD INTELLECTUAL PROPERTY ORGANIZATION
International Bureau

INTERNATIONAL APPLICATION PUBLISHED UNDER THE PATENT COOPERATION TREATY (PCT)

<p>(51) International Patent Classification ⁶ : C22C 29/02</p>	<p>A1</p>	<p>(11) International Publication Number: WO 99/10552 (43) International Publication Date: 4 March 1999 (04.03.99)</p>
<p>(21) International Application Number: PCT/IB98/01300 (22) International Filing Date: 20 August 1998 (20.08.98) (30) Priority Data: 08/918,979 27 August 1997 (27.08.97) US (63) Related by Continuation (CON) or Continuation-in-Part (CIP) to Earlier Application US 08/918,979 (CIP) Filed on 27 August 1997 (27.08.97) (71) Applicant (for all designated States except US): KEN-NAMETAL INC. [US/US]; 1600 Technology Way, Latrobe, PA 15650-0231 (US). (72) Inventors; and (75) Inventors/Applicants (for US only): HEINRICH, Hans-Wilm [DE/DE]; Bodenseering 103, D-95445 Bayreuth (DE). WOLF, Manfred [DE/DE]; Rathausstrasse 12 b, D-95488 Eckersdorf (DE). SCHMIDT, Dieter [DE/DE]; Hoffmann-von-Fallersleben-Strasse 32, D-95445 Bayreuth (DE). SCHLEINKOFER, Uwe [DE/US]; 104 Yellowstone Drive, Latrobe, PA 15650 (US).</p>	<p>(74) Agent: BUNKE, Holger; Prinz & Partner, Manzingerweg 7, D-81241 München (DE). (81) Designated States: AL, AM, AT, AU, AZ, BA, BB, BG, BR, BY, CA, CH, CN, CU, CZ, DE, DK, EE, ES, FI, GB, GE, GH, GM, HR, HU, ID, IL, IS, JP, KE, KG, KP, KR, KZ, LC, LK, LR, LS, LT, LU, LV, MD, MG, MK, MN, MW, MX, NO, NZ, PL, PT, RO, RU, SD, SE, SG, SI, SK, SL, TJ, TM, TR, TT, UA, UG, US, UZ, VN, YU, ZW, ARIPO patent (GH, GM, KE, LS, MW, SD, SZ, UG, ZW), Eurasian patent (AM, AZ, BY, KG, KZ, MD, RU, TJ, TM), European patent (AT, BE, CH, CY, DE, DK, ES, FI, FR, GB, GR, IE, IT, LU, MC, NL, PT, SE), OAPI patent (BF, BJ, CF, CG, CI, CM, GA, GN, GW, ML, MR, NE, SN, TD, TG). Published With international search report. With amended claims.</p>	
<p>(54) Title: A ROTARY EARTH STRATA PENETRATING TOOL WITH A CERMET INSERT HAVING A Co-Ni-Fe-BINDER</p>		
<p>(57) Abstract A rotary tool that includes an elongate tool body and a hard insert (16) affixed to the tool body is disclosed. The hard insert comprises a WC-cermet comprising tungsten carbide and about 5 wt.% to 19 wt.% Co-Ni-Fe-binder. The Co-Ni-Fe-binder is unique in that even when subjected to plastic deformation, the binder substantially maintains its face centered cubic (fcc) crystal structure and avoids stress and/or strain induced transformations.</p>		

-1-

A ROTARY EARTH STRATA PENETRATING TOOL
WITH A CERMET INSERT HAVING A Co-Ni-Fe-Binder

Background

5

The present invention pertains to a rotary tool for penetrating the earth strata such as, for example, a roof drill bit or a tri-cone drill bit, that has one or more hard inserts at the axially forward end. In the case of a roof drill bit, such a rotary tool has been typically used to drill holes in a mine roof. In the case of a tri-cone drill bit, such a rotary tool has been used to drill holes for oil wells and the like.

15

The typical rotary tool has a hard insert affixed at an axially forward end. The hard insert is the part of the rotary tool that first impinges upon the earth strata or other substrate. The hard insert is comprised of a tungsten carbide cermet (WC-cermet), also known as cobalt cemented tungsten carbide and WC-Co. Here, a cobalt binder (Co-binder) cements tungsten carbide particles together. Although hard inserts made of a WC-cermet having a Co-binder have achieved successful results, there are some drawbacks.

25

One drawback is that up to about 45 percent of the world's primary cobalt production is located in politically unstable regions (e.g., political regions that have experienced either armed or peaceful revolutions in the past decade and could still

experience additional revolutions). About 15 percent of the world's annual primary cobalt market is used in the manufacture of hard materials including WC-cermets. About 26 percent of the world's annual primary cobalt market is used in the manufacture of superalloys developed for advanced aircraft turbine engines - a factor contributing to cobalt being designated a strategic material. These factors not only contribute to the high cost of cobalt but also explain cobalt's erratic cost fluctuations. Consequently, cobalt has been relatively expensive, which, in turn, has raised the cost of the WC-cermet hard insert, as well as the cost of the overall rotary tool. Such an increase in the cost of the rotary tool has been an undesirable consequence of the use of Co-binder for the hard insert. Therefore, it would be desirable to reduce cobalt from the binder of WC-cermet hard inserts.

Furthermore, because of the principal locations of the largest cobalt reserves, there remains the potential that the supply of cobalt could be interrupted due to any one of a number of causes. The unavailability of cobalt would, of course, be an undesirable occurrence.

Rotary tools operate in environments that are corrosive. While the WC-cermet hard inserts have been adequate in such environments, there remains the objective to develop a hard insert which has improved corrosion resistance while maintaining essentially the same wear characteristics of WC-cermet hard inserts.

While the use of WC-cermet hard inserts has been successful, there remains a need to provide a hard insert which does not have the drawbacks, i.e., cost and the potential for unavailability, inherent with the use of cobalt set forth above. There also remains a need to develop a hard insert for use in corrosive environments that possess improved corrosion resistance

-3-

without losing any of the wear characteristics of WC-cermets having a Co-binder.

SUMMARY

5 In one embodiment, the invention is rotary tool comprising an elongate tool body that has an axially forward end and an axially rearward end. A hard insert is affixed to the rotary tool body at the axially forward end. The composition of the hard insert comprises about 5 weight percent (wt.%) to about 10 19 wt.% percent binder, and about 81 wt.% to 95 wt.% tungsten carbide. The binder comprises a cobalt-nickel-iron-binder (Co-Ni-Fe-binder).

15 In another embodiment, the invention is a hard insert for use in a rotary tool having an elongate tool body with an axially forward end, wherein the hard insert is affixed to the tool body at the axially forward end. The composition of the hard insert comprises about 5 wt.% to 19 wt.% binder, and about 81 wt.% to 95 wt.% tungsten carbide. The binder 20 comprises a Co-Ni-Fe-binder.

In still another embodiment, the invention is a rotatable cutting tool comprising an elongate tool body that has an axially forward end with a hard insert affixed to the tool body at the axially forward end. 25 The composition of the hard insert comprises about 5 wt.% to 19 wt.% binder. The binder comprises at least about 40 wt.% cobalt but not more than about 90 wt.% cobalt, the remainder consisting of nickel and iron and, optionally, incidental impurities, with at least about 4 wt.% nickel, and at least about 30 4 wt.% iron. The tungsten carbide has a grain size comprising about 1 micrometer (μm) to about 30 μm .

The invention illustratively disclosed herein may suitably be practiced in the absence of any

SUBSTITUTE SHEET (RULE 26)

-4-

element, step, component, or ingredient that is not specifically disclosed herein.

BRIEF DESCRIPTION OF THE DRAWINGS

5 These and other features, aspects, and advantages of the present invention will become better understood with reference to the following description, appended claims, and accompanying drawings where:

10 FIG. 1 is a side view of a roof drill bit of the style KCV4-1RR (Roof Rocket) made by Kennametal Inc. of Latrobe, Pennsylvania; and

FIG. 2 is a side view of a drill bit used for downhole drilling.

DESCRIPTION

15 Referring to FIG. 1, there is illustrated a roof drill bit, generally designated as 10, of the style KCV4-1RR (Roof Rocket) made and sold by Kennametal Inc. of Latrobe, Pennsylvania 15650 (the assignee of the present patent application). Roof drill bit 10 has an elongate body with an axially rearward end 12 and an axially forward end 14. A hard insert 16 is affixed to the elongate body 12 at the axially forward end 14 thereof. In addition to the style illustrated in FIG. 1, applicants contemplate that the roof drill bits which may use cutting inserts of the compositions set forth herein include the roof drill bit shown and described in pending United States Patent Application Serial No. [unknown at this time] filed on July 15, 1997 for a ROTATABLE CUTTING BIT ASSEMBLY WITH WEDGE-LOCK RETENTION ASSEMBLY by Ted R. Massa, Robert H. Montgomery, William P. Losch, and David R. Siddle, and assigned to Kennametal Inc. of Latrobe, Pennsylvania, and the roof drill bit shown and described in pending United States Patent Application

SUBSTITUTE SHEET (RULE 26)

Serial No. [unknown at this time] filed on July 15, 1997 for a ROTATABLE CUTTING BIT ASSEMBLY WITH CUTTING INSERTS by Ted R. Massa and David R. Siddle, and assigned to Kennametal Inc. of Latrobe, Pennsylvania.

5 Both of the above-mentioned pending patent applications filed on July 15, 1997 are hereby incorporated by reference herein.

10 Referring to the hard insert 16 of the roof drill bit 10, the composition of the hard insert 16 comprises a Co-Ni-Fe-binder and tungsten carbide (WC). The range of the Co-Ni-Fe-binder in the WC-cermet comprises about 5 wt.% to 19 wt.%.

15 Referring to FIG. 2, there is illustrated a drill bit, generally designated as 20, for downhole drilling such as is shown in United States Patent No. 4,108,260, for a ROCK BIT WITH SPECIALLY SHAPED INSERTS, to Bozarth. Drill bit 20 has a drill bit body 22 which receives a plurality of hard inserts 24, which are made from the same WC-cermet having a
20 Co-Ni-Fe-binder from which hard insert 16 is made. Thus, a description of a WC-cermet in conjunction with hard insert 16 will suffice for the description of the WC-cermet for hard insert 24.

25 In this regard, the composition of WC-cermet having a Co-Ni-Fe-binder from which the hard insert 16 for the roof drill bit 10 or the hard insert 50 for the tri-cone drill bit 40 comprises a Co-Ni-Fe-binder and tungsten carbide. The Co-Ni-Fe-binder comprises at least about 40 wt.% cobalt but not more than about
30 90 wt.% cobalt, at least about 4 wt.% nickel, and at least about 4 wt.% iron. Applicants believe that a Co-Ni-Fe-binder comprising not more than about 36 wt.% Ni and not more than about 36 wt.% Fe is preferred. A preferred Co-Ni-Fe-binder comprises about
35 40 wt.% to 90 wt.% Co, the remainder consisting of nickel and iron and, optionally, incidental impurities,

with about 4 wt.% to 36 wt.% Ni, about
4 wt.% to 36 wt.% Fe, and a Ni:Fe ratio from about
1.5:1 to 1:1.5. A more preferred Co-Ni-Fe-binder
comprises about 40 wt.% to 90 wt.% Co and a Ni:Fe ratio
5 of about 1:1. An even more preferred Co-Ni-Fe-binder
alloy comprises a cobalt:nickel:iron ratio of about
1.8:1:1.

The Co-Ni-Fe-binder of the present invention
is unique in that even when subjected to plastic
10 deformation, the binder maintains its face centered
cubic (fcc) crystal structure and avoids stress and/or
strain induced transformations. Applicants have
measured strength and fatigue performance in cermets
having Co-Ni-Fe-binders up to as much as about 2400
15 megapascal (MPa) for bending strength and up to as much
as about 1550 MPa for cyclic fatigue (200,000 cycles in
bending at about room temperature). Applicants believe
that substantially no stress and/or strain induced
phase transformations occur in the Co-Ni-Fe-binder up
20 to those stress and/or strain levels that leads to
superior performance.

The preferred range of Co-Ni-Fe-binder in the
WC-cermet comprises about 5 wt.% to 19 wt.%. A more
preferred range of the Co-Ni-Fe-binder in the WC-cermet
25 comprises about 5 wt.% to 15 wt.%. An even more
preferred range of Co-Ni-Fe-binder in the WC-cermet
comprises about 5 wt.% to 10 wt.%.

The grain size of the tungsten carbide (WC)
hard component comprises a broadest range of about 1
30 micrometers (μm) to 30 μm . A mediate range for the
grain size of the WC comprise about 1 μm to 15 μm .

Applicants contemplate that every increment
between the endpoints of ranges disclosed herein, for
example, binder content, binder composition, Ni:Fe
35 ratio, hard component grain size, hard component
content, ... etc. is encompassed herein as if it were

-7-

specifically stated. For example, a binder content range of about 5 wt.% to 19 wt.% encompasses about 1 wt.% increments thereby specifically including about 5 wt.%, 6 wt.%, 7 wt.%, ... 17 wt.%, 18 wt.% and 19 wt.% binder. While for example, for a binder composition the cobalt content range of about 40 wt.% to 90 wt.% encompasses about 1 wt.% increments thereby specifically including 40 wt.%, 41 wt.%, 42 wt.%, ... 88 wt.%, 89 wt.%, and 90 wt.% while the nickel and iron content ranges of about 4 wt.% to 36 wt.% each encompass about 1 wt.% increments thereby specifically including 4 wt.%, 5 wt.%, 6 wt.%, ... 34 wt.%, 35 wt.%, and 36 wt.%. Further for example, a Ni:Fe ratio range of about 1.5:1 to 1:1.5 encompasses about 0.1 increments thereby specifically including 1.5:1, 1.4:1, ... 1:1, ... 1:1.4, and 1:1.5). Furthermore for example, a hard component grain size range of about 1 μm to about 30 μm encompasses about 1 μm increments thereby specifically including about 1 μm , 2 μm , 3 μm , ... 28 μm , 29 μm , and 30 μm .

The present invention is illustrated by the following. It is provided to demonstrate and clarify various aspects of the present invention: however, the following should not be construed as limiting the scope of the claimed invention.

As summarized in Table 1, a WC-cermet having a Co-Ni-Fe-binder of this invention and a comparative conventional WC-cermet having a Co-binder were produced using conventional powder technology as described in, for example, "World Directory and Handbook of HARDMETALS AND HARD MATERIALS" Sixth Edition, by Kenneth J. A. Brookes, International Carbide DATA (1996); "PRINCIPLES OF TUNGSTEN CARBIDE ENGINEERING" Second Edition, by George Schneider, Society of Carbide and Tool Engineers (1989); "Cermet-Handbook", Hertel

SUBSTITUTE SHEET (RULE 26)

-8-

AG, Werkzeuge + Hartstoffe, Fuerth, Bavaria, Germany (1993); and "CEMENTED CARBIDES", by P. Schwarzkopf & R. Kieffer, The Macmillan Company (1960) - the subject matter of which is herein incorporated by reference in its entirety. In particular, Table 1 presents a summary of the nominal binder content in weight percent (wt.%), the nominal binder composition, and the hard component composition and amount (wt.%) for a WC-cermet of this invention and a comparative prior art WC-cermet having a Co-binder. That is, commercially available ingredients (as described in, for example, "World Directory and Handbook of HARDMETALS AND HARD MATERIALS" Sixth Edition) that had been obtained for each of the inventive and the conventional composition as described in Table 1 were combined in independent attritor mills with hexane for homogeneous blending over a period of about 4.5 hours. After each homogeneously blended mixture of ingredients was appropriately dried, green bodies having the form of a plate for properties evaluation were pressed. The green bodies were densified by vacuum sintering at about 1570°C for about one hour.

Sample	Nominal Binder Content (wt.%)	Nominal Binder Composition (wt.%)			Hard Component
		Co	Ni	Fe	WC*
Invention	9.5	4.5	2.5	2.5	Remainder
Conventional	9.5	9.5	-	-	Remainder

* starting powder -80+400 mesh (particle size between about 38 μm and 180 μm) macrocrystalline tungsten carbide from Kennametal Inc. Fallon, Nevada

SUBSTITUTE SHEET (RULE 26)

As summarized in Table 2, the density (g/cm³), the magnetic saturation (0.1 μTm³/kg), the coercive force (Oe, measured substantially according to International Standard ISO 3326: Hardmetals - Determination of (the magnetization) coercivity), the hardness (HV₃₀, measured substantially according to International Standard ISO 3878: Hardmetals - Vickers hardness test), the transverse rupture strength (MPa, measured substantially according to International Standard ISO 3327/Type B: Hardmetals - Determination of transverse rupture strength) and the porosity (measured substantially according to International Standard ISO 4505: Hardmetals - Metallographic determination of porosity and uncombined carbon) of the inventive and the conventional WC-cermets were determined. The WC-cermet having a Co-Ni-Fe-binder had a comparable hardness but an improved transverse rupture strength compared to the conventional WC-cermet having a Co-binder.

Table 2: Mechanical and Physical Properties for Invention and Compactive Conventional WC-Cermet of Table 1

Sample	Density (g/cm ³)	Magnetic Saturation 0.1μTm ³ /kg	Hc (Oe)	Hardness (HV30)	TRS (MPa)	Porosity
Invention	14.35	178	18	970	2288	A04
Conventional	14.44	173	54	960	1899	A06

It can thus be seen that applicants' invention provides for a rotary tool, as well as the hard insert for the rotary tool, which overcomes certain drawbacks inherent in the use of a Co-binder in the hard insert. More specifically, the use of a

-10-

Co-Ni-Fe-binder instead of a Co-binder alloy in the hard insert reduces the cost of the hard insert and the overall rotary tool. The use of a Co-Ni-Fe-binder instead of a Co-binder in the hard insert reduces the potential that the principal component, i.e., cobalt, for the binder will be unavailable due to political instability in those countries which possess significant cobalt reserves. It also becomes apparent that applicants' invention provides a rotary tool, and a hard insert therefor, which possess improved corrosion resistance without sacrificing wear properties equivalent to those of a WC-cermet hard insert having a Co-binder.

The patents and other documents identified herein, including United States patent application entitled, "A CERMET HAVING A BINDER WITH IMPROVED PLASTICITY" by Hans-Wilm Heinrich, Manfred Wolf, Dieter Schmidt, and Uwe Schleinkofer (the applicants of the present patent application) which was filed on the same date as the present patent application and assigned to Kennametal Inc. (the same assignee as the assignee of the present patent application), are hereby incorporated by reference herein.

Other embodiments of the invention will be apparent to those skilled in the art from a consideration of the specification or practice of the invention disclosed herein. It is intended that the specification and examples be considered as illustrative only, with the true scope and spirit of the invention being indicated by the following claims.

February 15, 1999

PCT/IB98/01300
KENNAMETAL INC.

5

Our reference: K 1600 WO Bj/sc

10

Claims

1. A rotary tool comprising:
an elongate tool body having an axially forward end and
an axially rearward end;
15 a hard insert affixed to the tool body at the axially
forward end thereof; and
the hard insert comprising a WC-cermet comprising
tungsten carbide and about 5 wt.% to 19 wt.% Co-Ni-Fe-binder
comprising about 40 wt.% to 90 wt.% cobalt, the remainder of
20 said binder consisting of nickel and iron and, optionally,
incidental impurities, with about 4 wt.% to 36 wt.% nickel,
about 4 wt.% to 36 wt.% iron, and a Ni:Fe ratio from about
1.5:1 to 1:1.5 wherein the Co-Ni-Fe-binder comprises a face
centered cubic (fcc) structure that substantially maintains
25 its fcc structure and does not experience stress and strain
induced transformations when subjected to plastic
deformation.

2. The rotary tool of claim 1 wherein the WC-cermet
30 comprises about 5 wt.% to 15 wt.% binder.

3. The rotary tool of claim 1 wherein the Co-Ni-Fe-
binder comprises a solid solution face centered cubic
alloy.

35

- 12 -

4. The rotary tool of claim 1 wherein the Co-Ni-Fe-binder comprises about 46 wt.% to 57 wt.% cobalt.

5. The rotary tool of claim 1 wherein the Co-Ni-Fe-binder comprises about 40 wt.% to 90 wt.% cobalt and a Ni:Fe ratio of about 1:1.

6. The rotary tool of claim 1 wherein the Co-Ni-Fe-binder comprises a cobalt:nickel:iron ratio of about 1.8:1:1.

7. The rotary tool of claim 1 wherein the tungsten carbide has a grain size comprising about 1 μm to 30 μm .

8. The rotary tool of claim 1 wherein the tungsten carbide has a grain size comprising about 1 μm to 25 μm .

9. The rotary tool of claim 1 wherein the tungsten carbide has a grain size comprising about 1 μm to 15 μm .

10. A hard insert for use in a rotary tool having an elongate tool body with an axially forward end, wherein the hard insert is affixed to the tool body at the axially forward end, the hard insert comprising a WC-cermet comprising tungsten carbide and about 5 wt.% to 19 wt.% Co-Ni-Fe-binder comprising about 40 wt.% to 90 wt.% cobalt, the remainder of said binder consisting of nickel and iron and, optionally, incidental impurities, with about 4 wt.% to 36 wt.% nickel, about 4 wt.% to 36 wt.% iron, and a Ni:Fe ratio from about 1.5:1 to 1:1.5 wherein the Co-Ni-Fe-binder comprises a face centered cubic (fcc) structure that substantially maintains its fcc structure and does not experience stress and strain induced transformations when subjected to plastic deformation.

11. The hard insert of claim 10 wherein the WC-cermet comprises about 5 wt.% to 15 wt.% binder.

- 13 -

12. The hard insert of claim 10 wherein the Co-Ni-Fe-binder comprises a solid solution face centered cubic alloy.

5 13. The hard insert of claim 10 wherein the Co-Ni-Fe-binder comprises about 46 wt.% to 57 wt.% cobalt.

10 14. The hard insert of claim 10 wherein the Co-Ni-Fe-binder comprises about 40 wt.% to 90 wt.% cobalt and a Ni:Fe ratio of about 1:1.

15 15. The hard insert of claim 10 wherein the Co-Ni-Fe-binder comprises a cobalt:nickel:iron ratio of about 1.8:1:1.

16. The hard insert of claim 10 wherein the tungsten carbide has a grain size comprising about 1 μm to 30 μm .

20 17. The hard insert of claim 10 wherein the tungsten carbide has a grain size comprising about 1 μm to 15 μm .

25 18. A rotary drilling tool comprising:
an elongate tool body having an axially forward end;
a hard insert affixed to the tool body at the axially forward end thereof; and

the hard insert comprising a WC-cermet consisting essentially of about 1 μm to 30 μm tungsten carbide and about 5 wt.% to 19 wt.% solid solution face centered cubic Co-Ni-Fe-binder comprising about 40 wt.% to 90 wt.% cobalt, 30 the remainder of said binder consisting of nickel and iron and, optionally, incidental impurities, with about 4 wt.% to 36 wt.% nickel, about 4 wt.% to 36 wt.% iron, and a Ni:Fe ratio from about 1.5:1 to 1:1.5, wherein the Co-Ni-Fe-binder 35 substantially maintains its fcc structure and does not experience stress or strain induced transformations when subjected to plastic deformation.

1/1

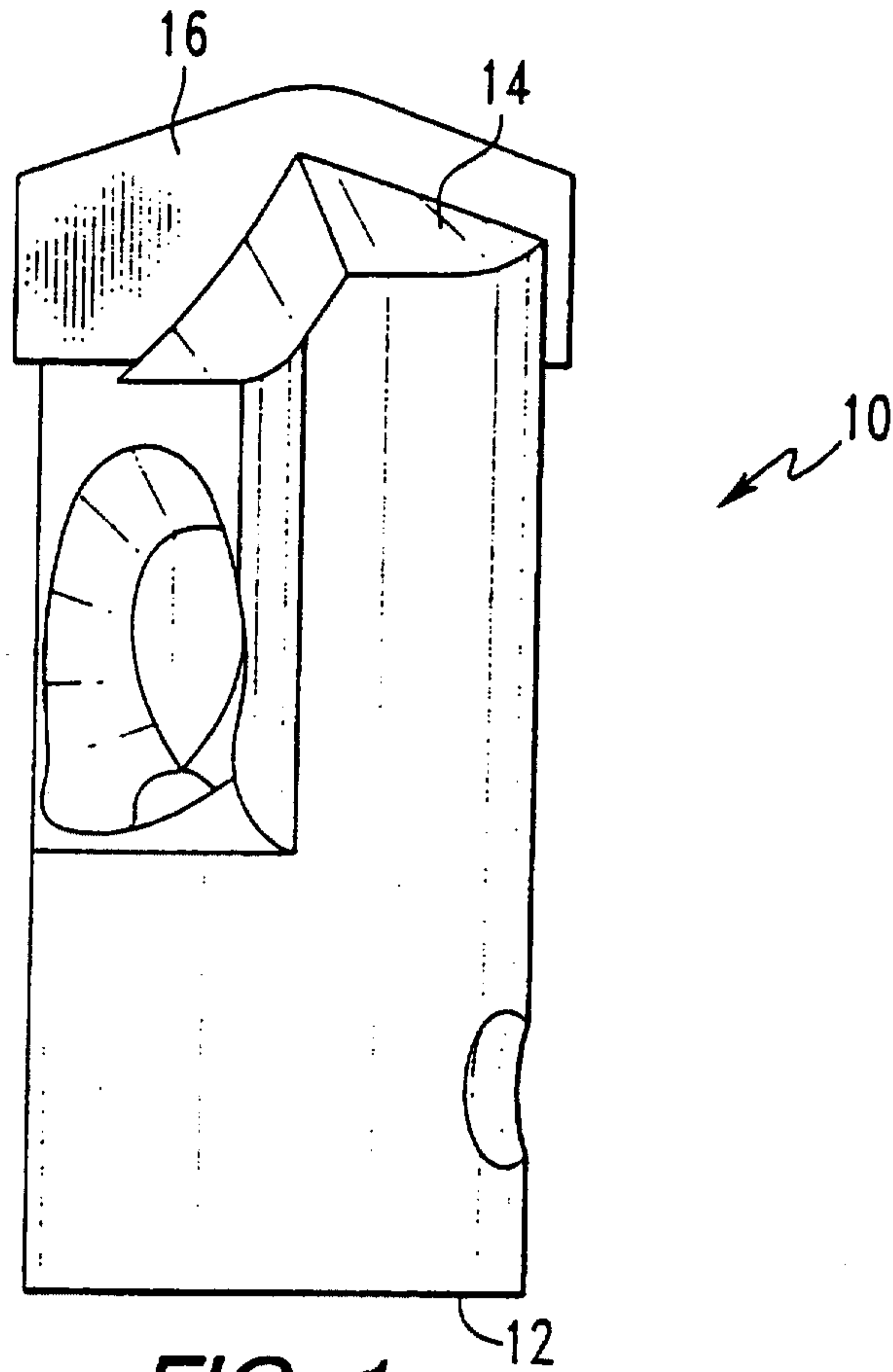

FIG. 1

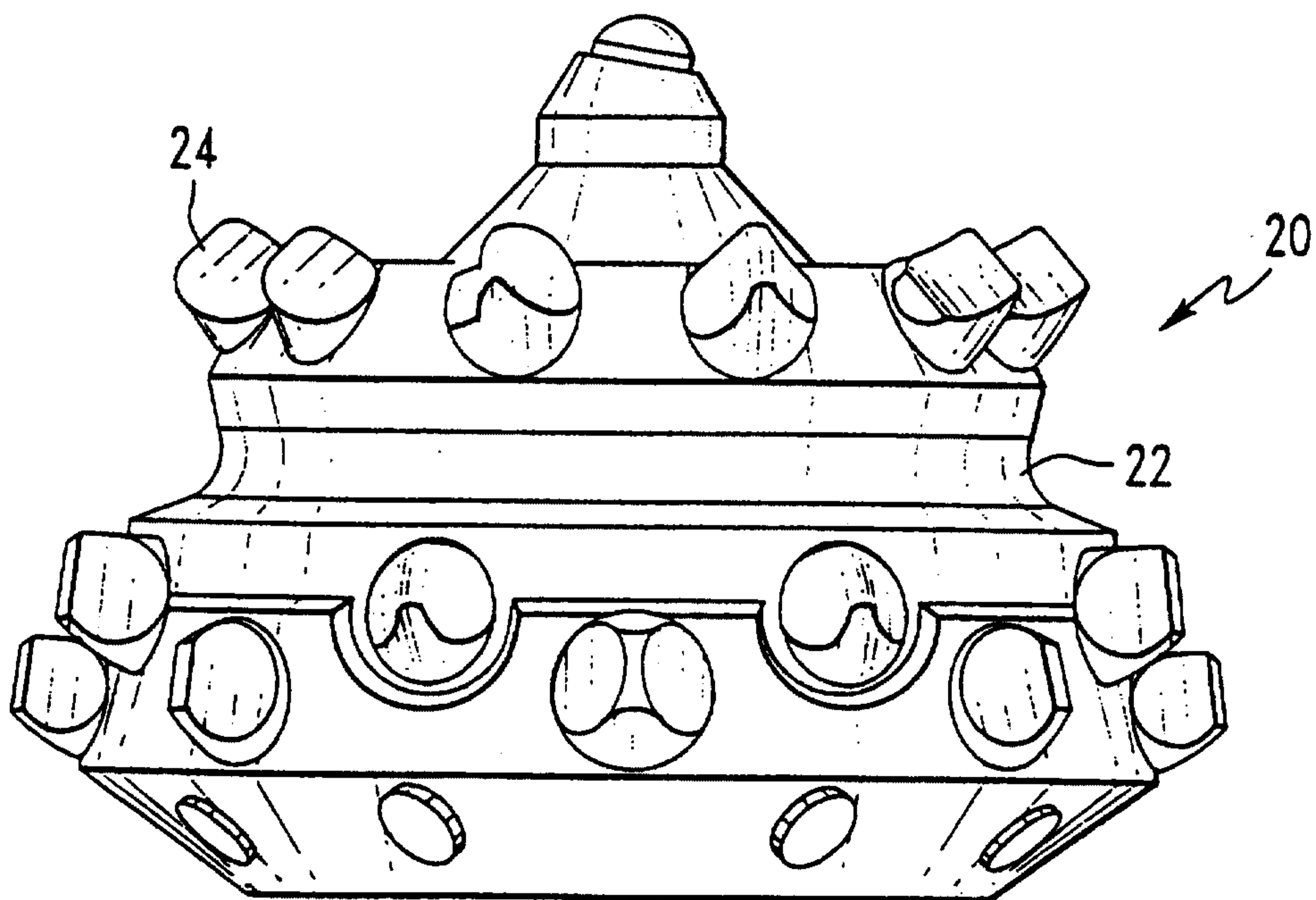

FIG. 2