

19



Europäisches Patentamt
European Patent Office
Office européen des brevets

11 Publication number:

**0 339 425
A2**

12

EUROPEAN PATENT APPLICATION

21 Application number: 89106833.0

51 Int. Cl.4: **H04R 1/30**

22 Date of filing: 17.04.89

30 Priority: 28.04.88 JP 106355/88
02.05.88 JP 109343/88

43 Date of publication of application:
02.11.89 Bulletin 89/44

64 Designated Contracting States:
ES IT SE

71 Applicant: **Matsushita Electric Industrial Co., Ltd.**
1006 Oaza Kadoma
Kadoma-shi Osaka(JP)

72 Inventor: **Tamura, Tadashi**
Shokoryo, 25-3, Midocho
Kadoma-shi(JP)
Inventor: **Saiki, Shuji**
11-88-208, Okayamatecho
Hirakata-shi(JP)
Inventor: **Sato, Kazue**
676-73, Neya
Neyagawa-shi(JP)

74 Representative: **Patentanwälte Leinweber & Zimmermann**
Rosental 7/II Aufg.
D-8000 München 2(DE)

54 **Speaker system.**

57 A speaker system which has a speaker unit with a diaphragm and an acoustic path (5) provided on the front side of the diaphragm so as to guide sound waves emitted from the diaphragm. The acoustic path (5) is defined by a sound absorbing member (4). The space in the acoustic path (5) and the sound absorbing member (4) is separated by a partition member (6) which is disposed in such a manner that at least a portion of the sound absorbing member (4) is exposed to the space in the acoustic path (5). This arrangement eliminates peaks and troughs of resonance determined by the length of the acoustic path (5), so that flat sound pressure frequency characteristics can be obtained over a wide range up to high-pitch tone region.

EP 0 339 425 A2

SPEAKER SYSTEM

BACKGROUND OF THE INVENTION

Field of the Invention

The present invention relates to a speaker system having a horn or an acoustic pipe provided in front of the speaker diaphragm and adapted for guiding sonic waves therefrom.

Description of the Prior Art

A speaker system is known in which a sound wave generated by a diaphragm is introduced to the second outlet opening of the speaker through a horn or an acoustic pipe provided on the front side of the diaphragm. This type of speaker systems is finding increasingly wide use because it provides a higher level of the output sound pressure and superior directivity as compared with ordinary speaker systems which do not have such a horn or acoustic pipe.

A description will be given hereinafter, with reference to the drawings, as to a known speaker system of the type having a horn or an acoustic pipe.

Referring to Fig. 9 which is a sectional view of a known speaker system of the type mentioned above, a back cavity 2 is provided on the rear side of a speaker unit 1 for the purpose of preventing radiation of reflected sound from the speaker diaphragm. A horn 9 is provided in front of the speaker diaphragm and extends towards the sound outlet opening of the speaker system. The cross-sectional area of the horn 9 is progressively increased from the end adjacent to the speaker diaphragm towards the end adjacent to the sound outlet opening of the speaker system. The horn 9 thus constitutes an acoustic path 5 which introduces the sound wave output from the speaker. The change in the acoustic impedance at the sound outlet opening of the speaker system is made extremely small provided that the horn 9 has a length which is sufficiently greater than the length of the wavelengths of sound wave of the reproduction band. In such a case, a very good matching is obtained at the sound outlet opening of the speaker system so that a flat reproduction sound pressure frequency characteristic is obtained thus realizing an ideal speaker system. Actually, however, in case of setting up the speaker system in an acoustic apparatus, it is not possible to design the horn 9 having such a large length in equipments which is sufficiently large as compared with the wavelength of sound waves in the re-

production band. Therefore, the speaker systems employing such horns usually exhibit a reproduction sound pressure frequency characteristic which contains many peaks and troughs as shown in Figs. 2B and 8B.

This is attributable to the fact that reflection waves are generated at the sound outlet opening of the speaker due to a drastic change in the acoustic impedance. In consequence, resonances are caused in the acoustic path. The same problem is encountered also with a speaker system which makes use of an acoustic pipe in place of the horn 9. Thus, the speaker systems which employ acoustic pipes as the acoustic paths exhibit reproduction sound pressure frequency characteristics which contain many peaks and troughs. This is attributed to the fact that, as shown in Fig. 10, a resonance takes place at a frequency f which is represented by the following formula:

$$f = (2n - 1)C/4L \quad (n = 1, 2, 3, \dots)$$

where, L represents the length of the acoustic pipe, while C represents the velocity of the sonic wave.

Fig. 10 illustrates the sound pressure distribution and velocity distribution as obtained when the number n is 2 (n = 2).

SUMMARY OF THE INVENTION

Accordingly, an object of the present invention is to provide a speaker system which provides a flat sound pressure frequency characteristics free of resonance peaks and troughs without requiring the length of the horn or the acoustic pipe to be increased.

To this end, according to the present invention, there is provided a speaker system comprising: an acoustic path provided on the front side of a speaker diaphragm and adapted for introducing a sound wave, the acoustic path being defined by a sound absorbing member; and a partition member which is disposed in the acoustic path in such a manner that at least a portion of the sound absorbing material is exposed to the interior of the acoustic path.

With this arrangement, the sound wave components reflected due to a drastic change in the acoustic impedance at the sound outlet opening are effectively absorbed by the sound absorbing member constituting the sound path, thereby providing flat sound pressure frequency characteristics with reduced peaks and troughs.

In addition, the components of the sound wave other than those which cause the peaks and troughs are introduced along the surface of the

partition member to the sound outlet opening of the speaker system, without being absorbed by the sound absorbing member, whereby the reproduction band can be broadened.

Japanese Patent Unexamined Publication No. 49-134312 discloses a speaker system in which a horn for guiding the sound wave from a diaphragm is made from a material which exhibits a small tendency of generation of reflected waves (noise), i.e., a material which absorbs the noise well. This, however, is irrelevant to the invention of this application which is intended for absorbing reflected waves attributable to a drastic change in the acoustic impedance at the sound outlet opening of the speaker system.

BRIEF DESCRIPTION OF THE DRAWINGS

Fig. 1 is a sectional view of a first embodiment of a speaker system in accordance with the present invention;

Fig. 2A is graph illustrating the sound pressure frequency characteristics of the first embodiment;

Fig. 2B is a graph illustrating the sound pressure frequency characteristics of known speaker system.

Figs. 3(a) to 3(c) are perspective views of different examples of the first embodiment;

Fig. 4 is a sectional view of a second embodiment of the speaker system in accordance with the present invention;

Fig. 5 is a sectional view of a third embodiment of the speaker system in accordance with the present invention;

Figs. 6(a) and 6(b) are a sectional view and a front elevational view of an essential part of a fourth embodiment of the speaker system of the present invention;

Fig. 7 is a sectional view of a fifth embodiment of the speaker system of the present invention;

Fig. 8A is a graph showing the sound pressure frequency characteristics of the fifth embodiment;

Fig. 8B is a graph illustrating the sound pressure frequency characteristics of known speaker system;

Fig. 9 is a sectional view of a known speaker system; and

Fig. 10 is an illustration of particle velocity distribution and sound pressure distribution in a longitudinal section of the acoustic pipe.

DESCRIPTION OF THE PREFERRED EMBODIMENTS

Preferred embodiments of the present invention will be described hereinafter with reference to the accompanying drawings.

Referring to Fig. 1, a first embodiment of the speaker system of the present invention has a speaker unit 1 with a back cavity 2 on the rear side thereof, an acoustic pipe 3 for guiding and introducing sound waves generated on the front side of the diaphragm of the speaker unit 1, and a sound absorbing member 4 disposed in the acoustic pipe 3 and defining an acoustic path 5.

The operation of this speaker system is as follows. The sound emitted from the rear side of the speaker unit 1 is confined in the back cavity 2 so that it is not transmitted to the outside of the speaker system. On the other hand, the sound emitted from the front side of the diaphragm is introduced through the acoustic pipe 3 to the sound outlet opening of the speaker system so as to be radiated therefrom. However, a part of the sound wave introduced to the sound outlet opening is reflected due to a drastic change in the acoustic impedance, tending to propagate backward to the diaphragm surface. According to the invention, the reflected sound wave is conveniently absorbed by the sound absorbing material disposed in the acoustic pipe, thus eliminating existence of a standing wave in the acoustic pipe.

As will be seen from Fig. 1, the sound absorbing member 4 has a smaller thickness in the region near the sound outlet opening and a greater thickness at the region adjacent to the speaker unit 1, so that the impedance of the sound absorbing member 4 to the reflected wave is reduced to ensure a high sound absorbing effect.

Namely, the amount of the material of the sound absorbing member 4 is increased towards the front side of the diaphragm so that the impedance exhibited by the sound absorbing member 4 to the reflected sound wave is linearly changed, whereby the reflected sound wave from the sound outlet opening is effectively absorbed by the sound absorbing member without any unnecessary reflection.

The linear and progressive change in the impedance provided by the sound absorbing member may be controlled in various ways. For instance, it is possible to control the manner of change in the impedance by suitably varying the amount of the material of the sound absorbing member 4 along the length thereof, or by adjusting the flow resistance per unit area such that it is small in the region near the sound outlet opening and large in the region near the surface of the diaphragm.

Needless to say, the sound wave produced by the diaphragm can be introduced to the sound outlet opening through the acoustic path defined by the sound absorbing member 4 without being im-

peded by the sound absorbing member 4.

Fig. 2 illustrates the reproduction sound pressure frequency characteristics exhibited by a speaker system with the horn or acoustic pipe in accordance with the first embodiment, in comparison with the characteristics exhibited by the conventional arrangement. From this Figure, it will be understood that the conventional speaker system exhibits characteristics B which includes peaks and troughs due to existence of a standing wave, while the speaker system of the first embodiment exhibits flat reproduction sound pressure frequency characteristics A up to high pitch region of the tone.

In the first embodiment as described, the cross-sectional area of the acoustic path is increased from the end adjacent to the surface of the diaphragm towards the sound outlet opening. Such an acoustic path 5 may be defined solely by the sound absorbing member 4 as shown in Fig. 3(a) or, alternatively, the arrangement may be such that the sound absorbing member 4 and the wall of the acoustic pipe 3 in cooperation define the acoustic path 5, as shown in Fig. 3(b).

The advantages brought about by this embodiment can be enjoyed also when the acoustic path 5 has a tubular form of a constant cross-sectional area. The same advantages are derived also from an arrangement of Fig. 3(c) in which the sound absorbing member 4 has a horn-like form, while the acoustic pipe 3 is constructed to decrease its cross-sectional area towards the sound outlet opening, thus providing a constant cross-sectional area of the acoustic path 5, as shown in Fig. 3(c).

Fig. 4 is a sectional view of a second embodiment of the speaker system in accordance with the present invention.

The second embodiment of the speaker system has a speaker unit 1, a back cavity 2, an acoustic pipe for introducing acoustic waves generated on the front side of the diaphragm, a partition member 6 disposed in the acoustic pipe 3 so as to define an acoustic path 5, and a sound absorbing member 4 a part of which is disposed between the partition member 6 and the wall of the acoustic pipe 3 while the other part is exposed so as to define the acoustic path 5.

The operation of the second embodiment is as follows. The sound wave emitted from the rear side of the diaphragm in the speaker unit 1 is confined in the back cavity 2 so that it does not radiate to the outside. On the other hand, the sound wave emitted from the front side of the diaphragm is guided by the acoustic pipe 3 to reach the sound outlet opening so as to be radiated therefrom. However, since a drastic change in the acoustic impedance is generated in the sound outlet opening, a portion of the sound wave introduced to the

opening is reflected so as to be propagated backward towards the front surface of the diaphragm. However, the reflected wave is absorbed by the sound absorbing member 4 disposed in the acoustic pipe 3, so that no standing wave exists in the acoustic pipe 3.

The partition member 6 is so sized as to extend over about 1/3 of the acoustic pipe 3 as measured from the surface of the diaphragm, and is intended to effectively guide the high-pitch components of the sound which tend to be absorbed by the sound absorbing member 4.

The portion of the acoustic pipe 3 which is about 1/3 the whole length of the acoustic pipe 3 as measured from the surface of the diaphragm substantially coincides with the region where the particle velocity is high. It is therefore possible to suppress the peaks of the sound pressure in the frequency region in which the standing wave is generated. The sound wave components of other frequencies are introduced efficiently to the sound outlet opening without being impeded by the sound absorbing member, because the sound absorbing member is designed in the form of a horn.

According to this embodiment, therefore, it is possible to suppress the levels of the peaks of sound pressure which are inevitably high in the conventional speaker system with a horn or acoustic pipe due to the existence of a standing wave.

Obviously, the second embodiment can be carried out with various forms of the acoustic path 5 as illustrated in Figs. 3(a) to 3(c), without impairing the advantages derived therefrom.

Fig. 5 shows a third embodiment of the speaker system of the present invention. The third embodiment has a speaker unit 1, a back cavity 2, an acoustic pipe 3 for guiding sound wave generated on the front side of the diaphragm in the speaker unit 1, a partition member 6 disposed in the acoustic pipe 3 so as to define an acoustic path 5 and having slits one of which is located near the sound outlet opening of the acoustic pipe 3 while the other is in the region which is about 1/3 of the full length of the acoustic pipe 3 as measured from the surface of the speaker diaphragm, and a sound absorbing material received in the space between the acoustic pipe 3 and the partition member 6.

The operation of the speaker system in accordance with the third embodiment is as follows. The sound wave emitted from the rear side of the speaker unit 1 is confined in the back cavity 2 so that it does not radiate outside. On the other hand, the sound from the front side of the diaphragm in the speaker unit 1 is guided by the acoustic pipe 3 to reach the sound outlet opening so as to be radiated therefrom. A portion of the sound wave reaching the sound outlet opening, however, is reflected because the acoustic impedance is dras-

tically changed at the sound outlet opening. The reflected wave tends to propagate backward towards the surface of the diaphragm. The reflected wave, however, is effectively absorbed by the sound absorbing member 4 in the acoustic pipe 3 so that no standing wave is generated in the acoustic pipe.

As explained before, the partition member 6 has slits in the region near the sound outlet opening and in the region which is 1/3 of the full length of the acoustic pipe 3 as measured from the surface of the speaker diaphragm, i.e., in the regions where the particle velocity is high. It is therefore possible to selectively absorb the sound wave components of frequency regions having peaks of sound pressure. Other components of the sound wave can be guided to the sound outlet opening without being impeded by the sound absorbing member 4.

Thus, the third embodiment also provides flat sound pressure frequency characteristics, by suppressing the peaks of sound pressure which are inevitably high in the known horn or acoustic pipe due to the presence of a standing wave.

Obviously, the same advantages are brought about when the acoustic path 5 of the third embodiment is modified as shown in Figs. 3(a) to 3(c).

Figs. 6(a) and 6(b) show a fourth embodiment of the speaker system in accordance with the present invention. As will be seen from Fig. 6(a), the fourth embodiment has a speaker unit 1, a back cavity 2, an acoustic pipe 3 which guides the sound wave generated on the front side of the diaphragm of the speaker unit 1, a partition member 6 disposed in the acoustic pipe 3 so as to define an acoustic path 5 and having a plurality of apertures, and a sound absorbing member 4 filling the space between the wall of the acoustic pipe 3 and the partition member 6.

As will be seen from Fig. 6(b), the apertures 10 formed in the partition member 6 have a diameter of 8 mm and are arranged at a pitch of 30 mm.

The operation of the fourth embodiment of the speaker system will be described hereinafter. The sound emitted from the rear side of the diaphragm of the speaker unit 1 is confined in the back cavity 2 so that it does not radiate to the outside. On the other hand, the sound wave emitted from the front side of the diaphragm is guided to the sound outlet opening through the acoustic pipe 3 so as to be radiated therefrom. A portion of the sound wave reaching the sound outlet opening of the acoustic pipe 3, however, is reflected to propagate backward towards the front surface of the diaphragm, because a drastic change in the acoustic impedance takes place at the sound outlet opening. The reflected sound wave, however, is absorbed by the sound absorbing member 4 which continuously ex-

tends over the entire area of the inner surface of the acoustic pipe 3 so that establishment of standing wave in the acoustic pipe 3 is prevented.

In this embodiment, the partition member 6 has apertures 10 of 8 mm diameter arranged at a pitch of 30 mm. The reflected sound wave causes a resonance with the air in the apertures so that a large sound absorption rate is obtained in the region near 1 KHz, thus enabling absorption of the second peak of the sound pressure in the acoustic pipe 3 which has a length of 40 cm. Other peaks are directly absorbed by the sound absorbing member 4 rather than by resonance with the air in the apertures. The diameter and the pitch of the apertures 10 can be varied as desired to enable absorption of the peak of a variety of frequency regions. Obviously, the configuration of the acoustic path 5 may be varied as illustrated in Figs. 3(a) to 3(c), without impairing the advantages.

Fig. 7 shows a fifth embodiment of the speaker system in accordance with the present invention. This embodiment has a high-pitch tone speaker unit 7, a low-pitch tone speaker 8, a back cavity 2, an acoustic pipe 3 for guiding the sound waves generated on the front surfaces of both speaker units 7 and 8, a partition member 6 disposed in the acoustic pipe 3 so as to define an acoustic path 5 and having slits one of which is located near the sound outlet opening of the acoustic pipe 3 while the other is in a region which is about 1/3 of the full length of the acoustic pipe as measured from the end surface of the diaphragm in the speaker unit, and a sound absorbing member 4 disposed in the space defined between the wall of the acoustic pipe 3 and the partition member 6.

The operation of the speaker system in accordance with the fifth embodiment is as follows. The sound waves emitted from the rear side of the high-pitch and low-pitch tone speaker units 7 and 8 are confined in the back cavity 2 so that it does not radiate outside. On the other hand, the sound waves from the front side of the diaphragm in the speaker units 7 and 8 are guided by the acoustic pipe 3 to reach the sound outlet opening so as to be radiated therefrom. A portion of the sound waves reaching the sound outlet opening, however, is reflected because the acoustic impedance is drastically changed at the sound outlet opening. The reflected wave tends to propagate backward towards the surface of the diaphragm. The reflected wave, however, is effectively absorbed by the sound absorbing member 4 in the acoustic pipe 3 so that no standing wave is generated in the acoustic pipe.

As explained before, the partition member 6 has slits in the region near the sound outlet opening and in the region which is 1/3 of the full length of the acoustic pipe 3 as measured from the sur-

face of the speaker diaphragm, i.e., in the regions where the particle velocity is high. It is therefore possible to selectively absorb the sound wave components of frequency regions having peaks of sound pressure. Other components of the sound wave can be guided to the sound outlet opening without being impeded by the sound absorbing member 4.

Fig. 8 illustrates the reproduction sound pressure frequency characteristics exhibited by a speaker system with the horn or acoustic pipe in accordance with the fifth embodiment, in comparison with the characteristics exhibited by the conventional arrangement. From this Figure, it will be understood that the conventional speaker system exhibits characteristics B which includes peaks and troughs due to existence of a standing wave, while the speaker system of the fifth embodiment exhibits flat reproduction sound pressure frequency characteristics A up to high pitch region of the tone.

Thus, the fifth embodiment also provides flat sound pressure frequency characteristics, by suppressing the peaks of sound pressure which are inevitably high in the known horn or acoustic pipe due to the presence of a standing wave.

Obviously, the advantages offered by the fifth embodiment can equally be enjoyed even when the acoustic path 5 is modified as illustrated in Figs 3(a) to 3(c).

Claims

1. A speaker system comprising: at least one speaker unit having a diaphragm; an acoustic path for guiding sound waves generated on the front surface of said diaphragm; and a sound absorbing member provided in a predetermined portion of said acoustic path.

2. A speaker system according to Claim 1, wherein said predetermined portion is located near resonance points of standing waves in said acoustic path.

3. A speaker system according to Claim 1, wherein said acoustic path is defined by a member made of a sound absorbing material, further comprising a partition member which is disposed to separate said sound absorbing member from said acoustic path in such a manner that at least a portion of said sound absorbing member is exposed to said acoustic path.

4. A speaker system according to Claim 3, wherein said partition member extends from the front surface of said diaphragm to a position which is spaced from said front surface of said diaphragm by about 1/3 of the full length of said acoustic path.

5. A speaker system according to Claim 3, wherein the region where said sound absorbing member is exposed is a region where the particle velocity distribution of standing waves in said acoustic path is large.

6. A speaker system according to Claim 5, wherein said sound absorbing member is exposed in a region which is spaced from the front surface of said diaphragm by about 1/3 of the full length of said acoustic path and a region which is near the sound outlet opening of said acoustic path.

7. A speaker system according to anyone of Claims 1 to 3, wherein the cross-sectional area of said acoustic path is progressively increased from the end near said diaphragm towards the end near said sound outlet opening.

8. A speaker system according to Claim 3, wherein said acoustic path has a constant cross-sectional area over the entire length thereof.

9. A speaker system according to either one of Claims 7 and 8, wherein said acoustic path is defined by the wall of said sound absorbing member and the wall of an acoustic pipe.

10. A speaker system according to anyone of Claims 1 to 3, wherein said acoustic path is provided commonly on the front side of a plurality of speaker units.

11. A speaker system according to anyone of Claims 1 to 10, wherein said sound absorbing member is provided in an acoustic pipe.

12. A speaker system according to Claim 3, wherein the amount of the material of said sound absorbing member is progressively decreased from the end near said diaphragm towards the end near said sound outlet opening.

13. A speaker system according to anyone of Claims 1 to 3, wherein the flow resistance per unit area of said sound absorbing member is progressively decreased from the end near said diaphragm towards the end near said sound outlet opening.

FIG. 1

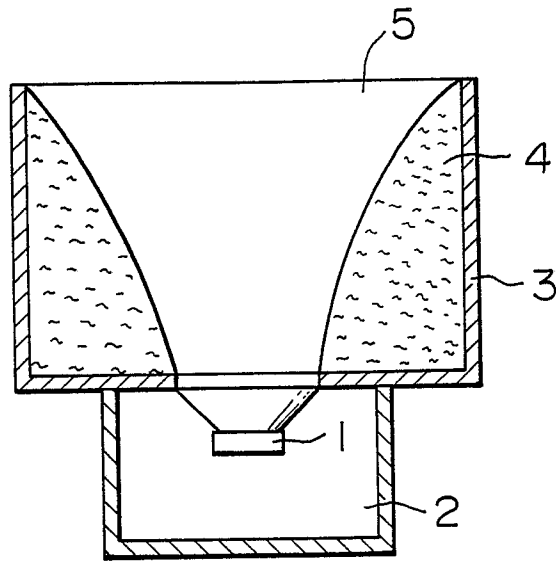

FIG. 2

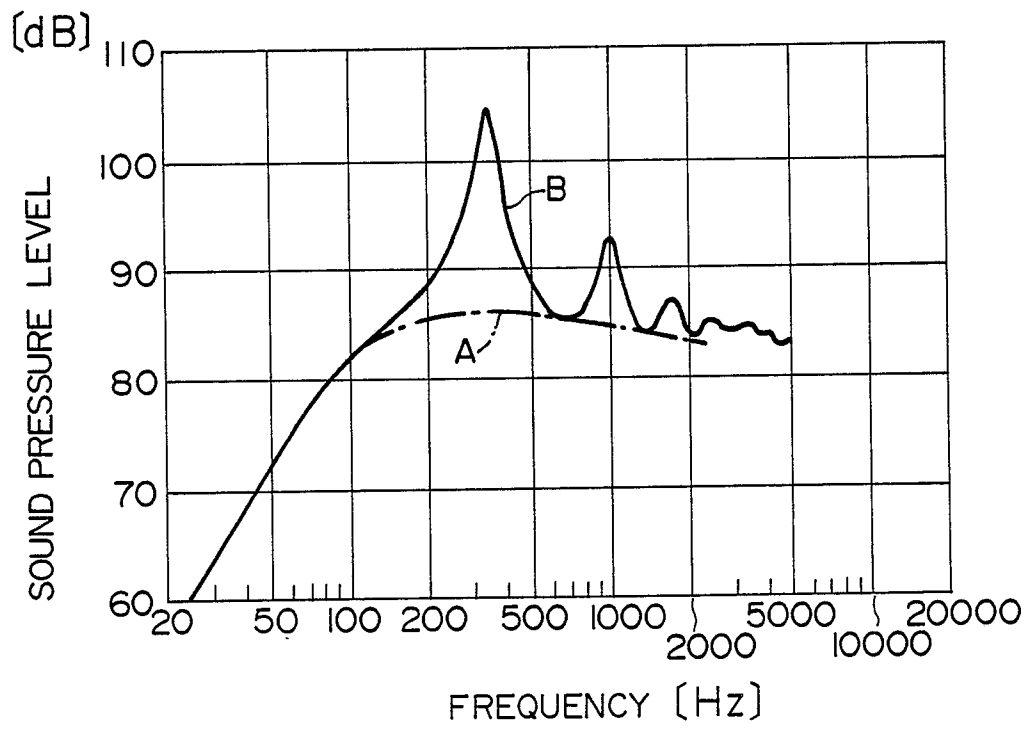

FIG. 3(a)

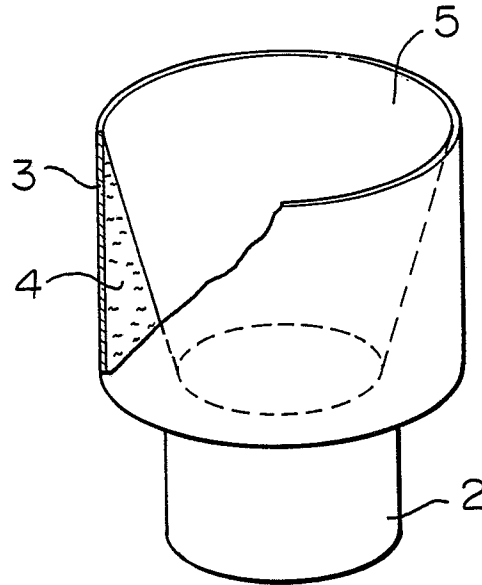

FIG. 3(b)

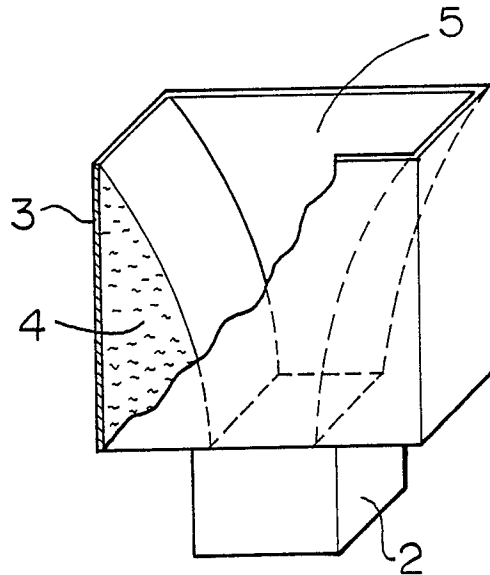

FIG. 3(c)

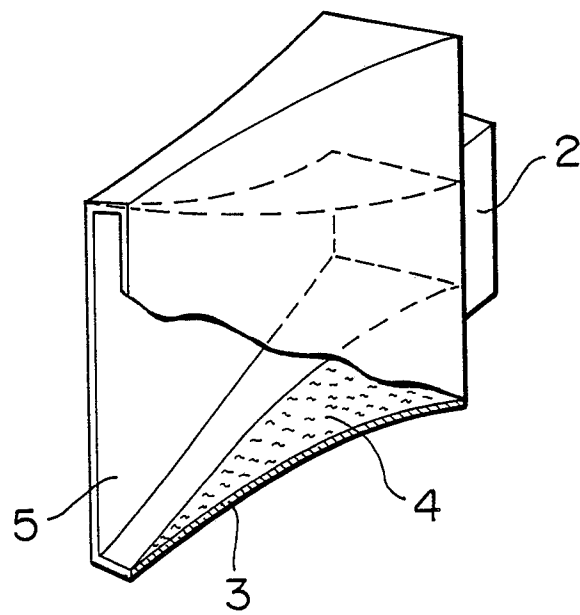

FIG. 4

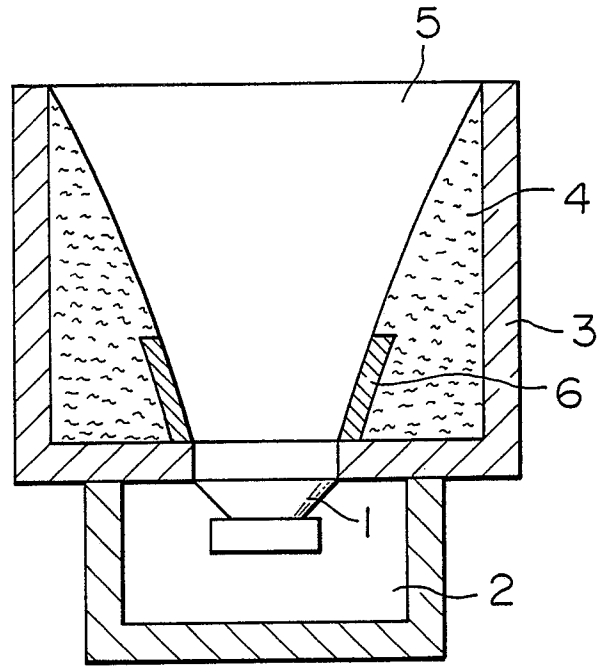

FIG. 5

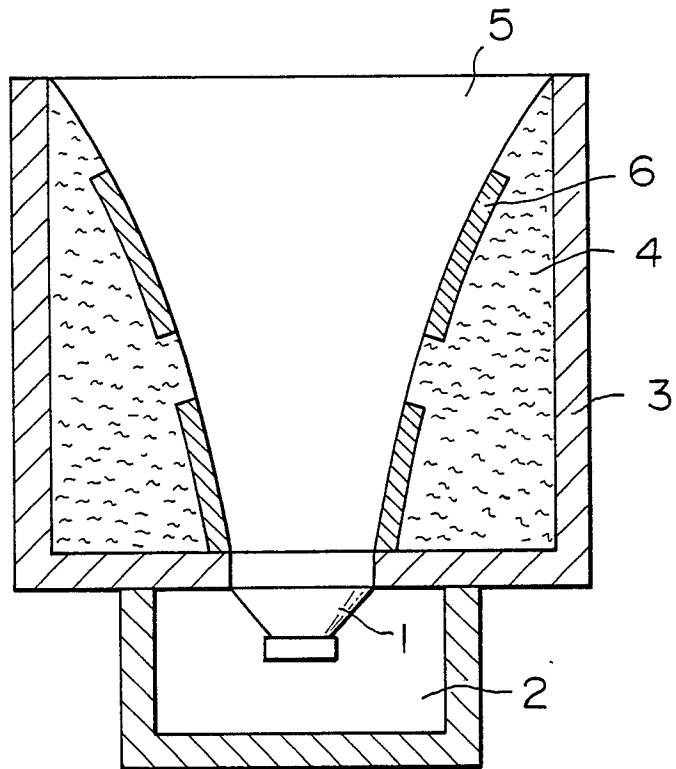

FIG. 6 (a)

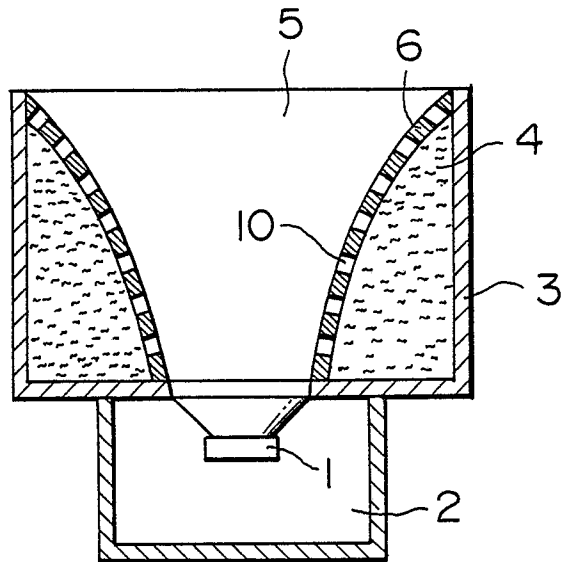

FIG. 6 (b)

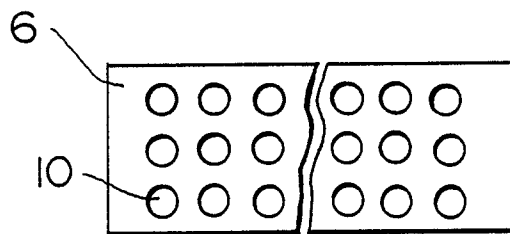

FIG. 7

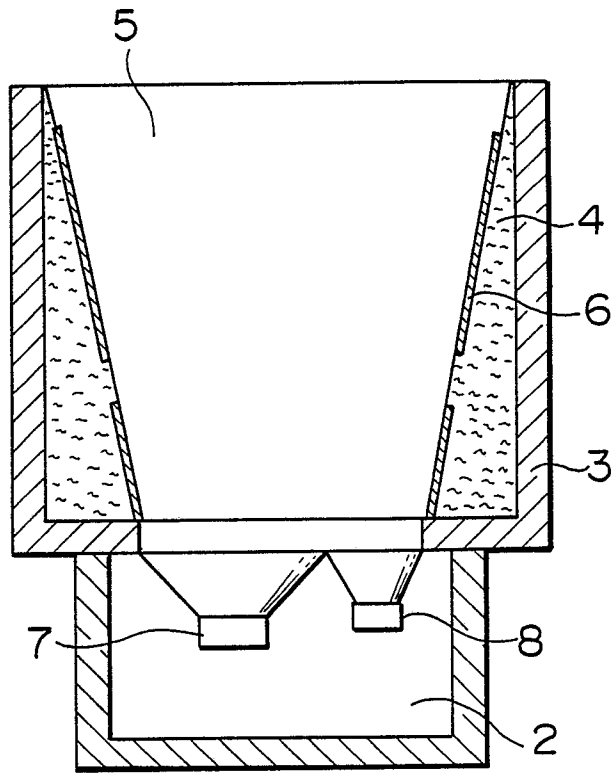

FIG. 8

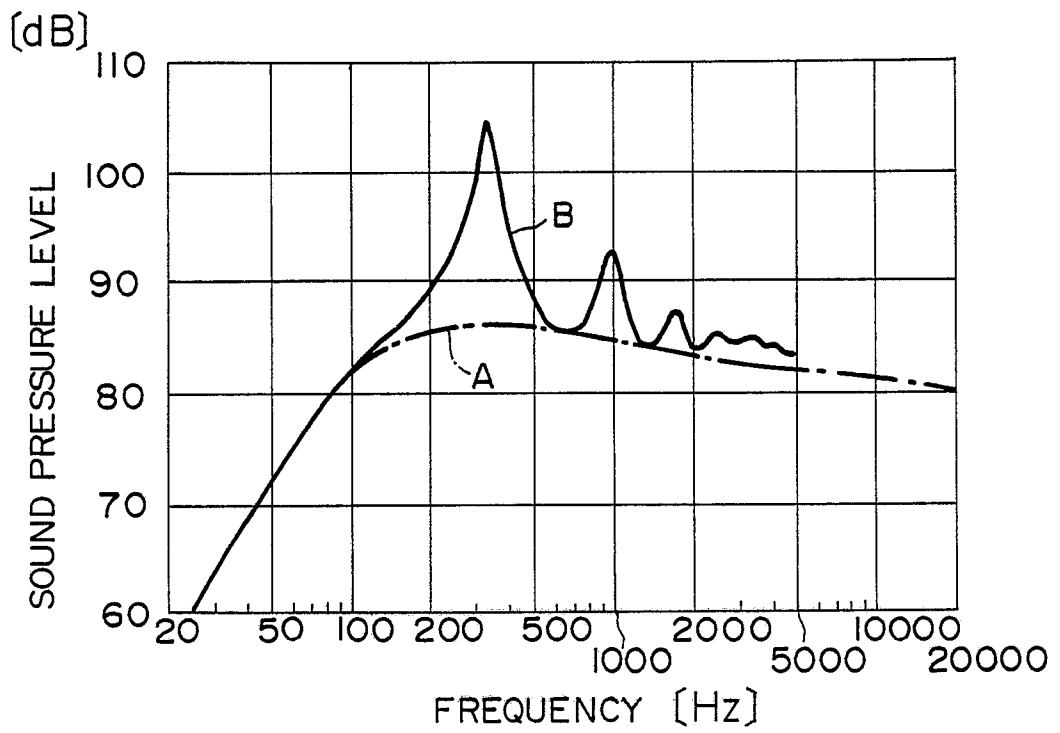

FIG. 9

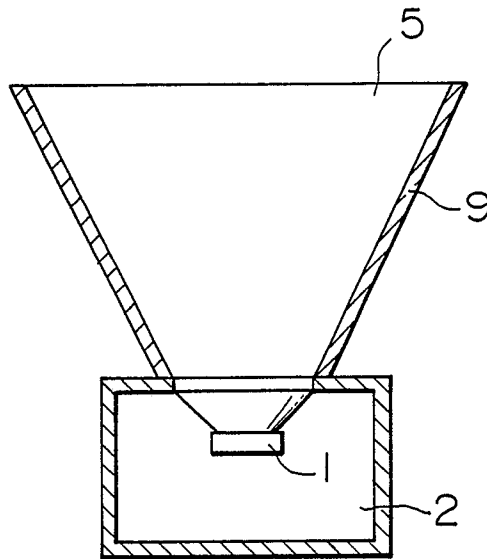

FIG. 10

$$f = 3C/4L$$

C = SOUND VELOCITY

L = ACOUSTIC PIPE LENGTH

