



US00D455259S

(12) **United States Design Patent**  
**Kelly-Pollet**

(10) **Patent No.:** **US D455,259 S**

(45) **Date of Patent:** **\*\* Apr. 9, 2002**

(54) **SKATE BOARD CARRIER**

(75) Inventor: **Patt Kelly-Pollet**, Sammamish, WA  
(US)

(73) Assignee: **Bensussen Deutsch & Associates, Inc.**,  
Woodinville, WA (US)

(\*\*) Term: **14 Years**

(21) Appl. No.: **29/139,635**

(22) Filed: **Apr. 2, 2001**

(51) **LOC (7) Cl.** ..... **03-01**

(52) **U.S. Cl.** ..... **D3/221; D3/261**

(58) **Field of Search** ..... D3/215, 221, 225,  
D3/226, 230, 201, 216, 254, 261, 269,  
315, 327; 224/257, 917, 600, 201, 901.4,  
901.6

(56) **References Cited**

**U.S. PATENT DOCUMENTS**

D226,810	S	*	5/1973	Winfrey	.....	D3/254
4,308,982	A	*	1/1982	Hall	.....	224/917
4,337,883	A	*	7/1982	Pats		
4,470,528	A	*	9/1984	Dyess	.....	224/257
5,092,506	A	*	3/1992	Boldus	.....	224/901.6
5,383,587	A	*	1/1995	Carpenter	.....	224/257
5,492,254	A	*	2/1996	Challoner et al.	.....	224/257
D391,075	S	*	2/1998	Jackson et al.	.....	D3/254
5,746,361	A	*	5/1998	Johnson		
5,934,533	A	*	8/1999	Callanan		

\* cited by examiner

*Primary Examiner*—Lucy Lieberman

(74) *Attorney, Agent, or Firm*—Richardson & Folise

(57) **CLAIM**

The ornamental design for a skate board carrier, as shown and described.

**DESCRIPTION**

FIG. 1 is a perspective view of a skate board carrier of the present invention shown in use by a user. The user and exemplary skateboard are shown in phantom for illustrative purposes only, and are not a part of the claimed design.

FIG. 2 is a front elevational view of the skate board carrier shown in an in-use configuration.

FIG. 3 is a right side elevational view of the skate board carrier shown in an in-use configuration.

FIG. 4 is a rear elevational view of the skate board carrier shown in an in-use configuration.

FIG. 5 is a left side elevational view of the skate board carrier shown in an in-use configuration.

FIG. 6 is a top plan view of the skate board carrier shown in an in-use configuration.

FIG. 7 is a bottom plan view of the skate board carrier shown in an in-use configuration.

FIG. 8 is a front elevational view of the skate board carrier shown in an unfolded configuration; and,

FIG. 9 is a rear elevational view of the skate board carrier shown in an unfolded configuration.

**1 Claim, 4 Drawing Sheets**

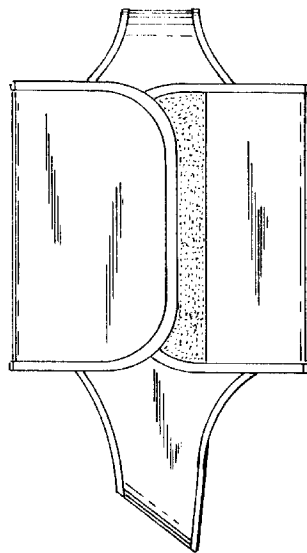
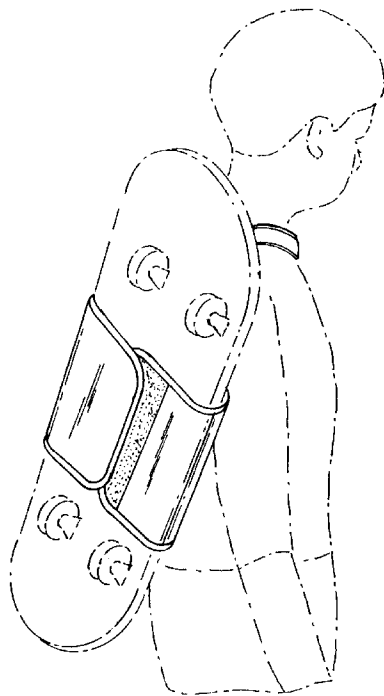

FIG. 2

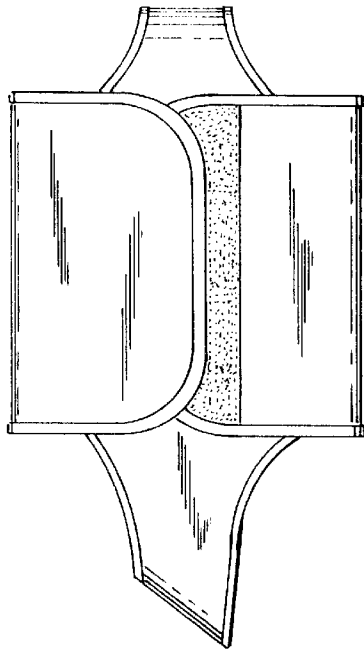

FIG. 3

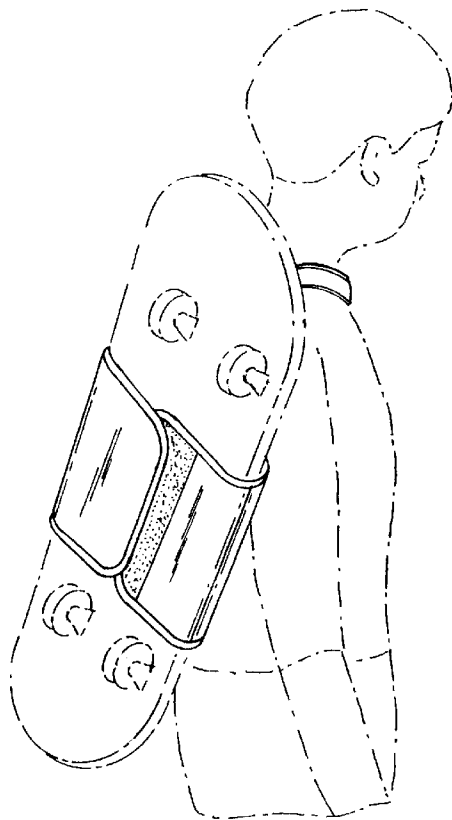
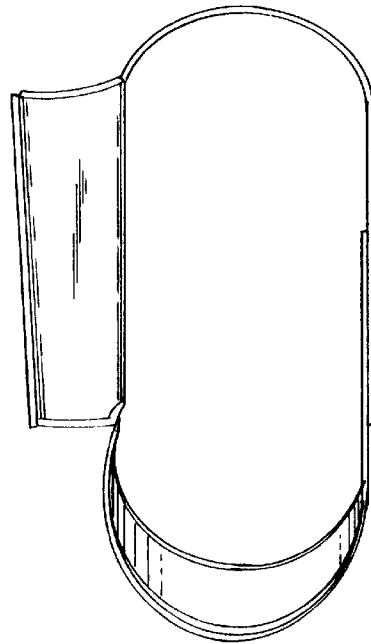

FIG. 1

FIG. 4

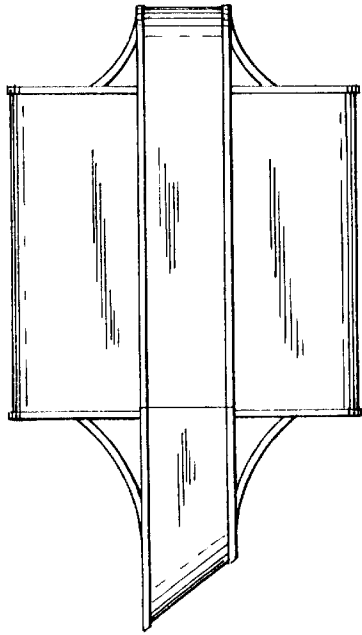

FIG. 5

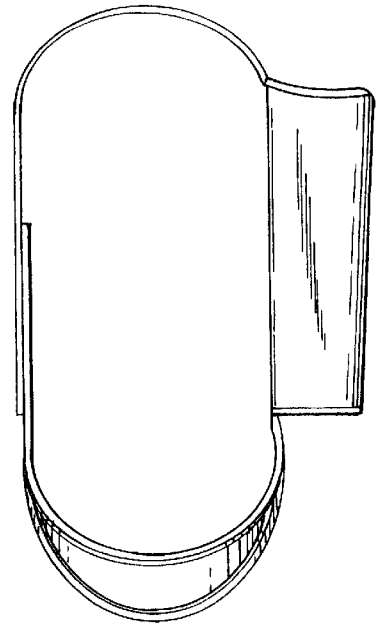

FIG. 6

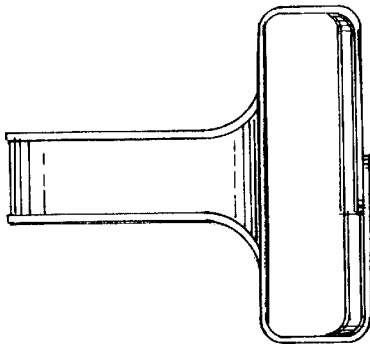

FIG. 7

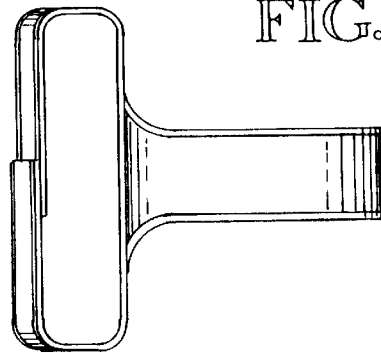
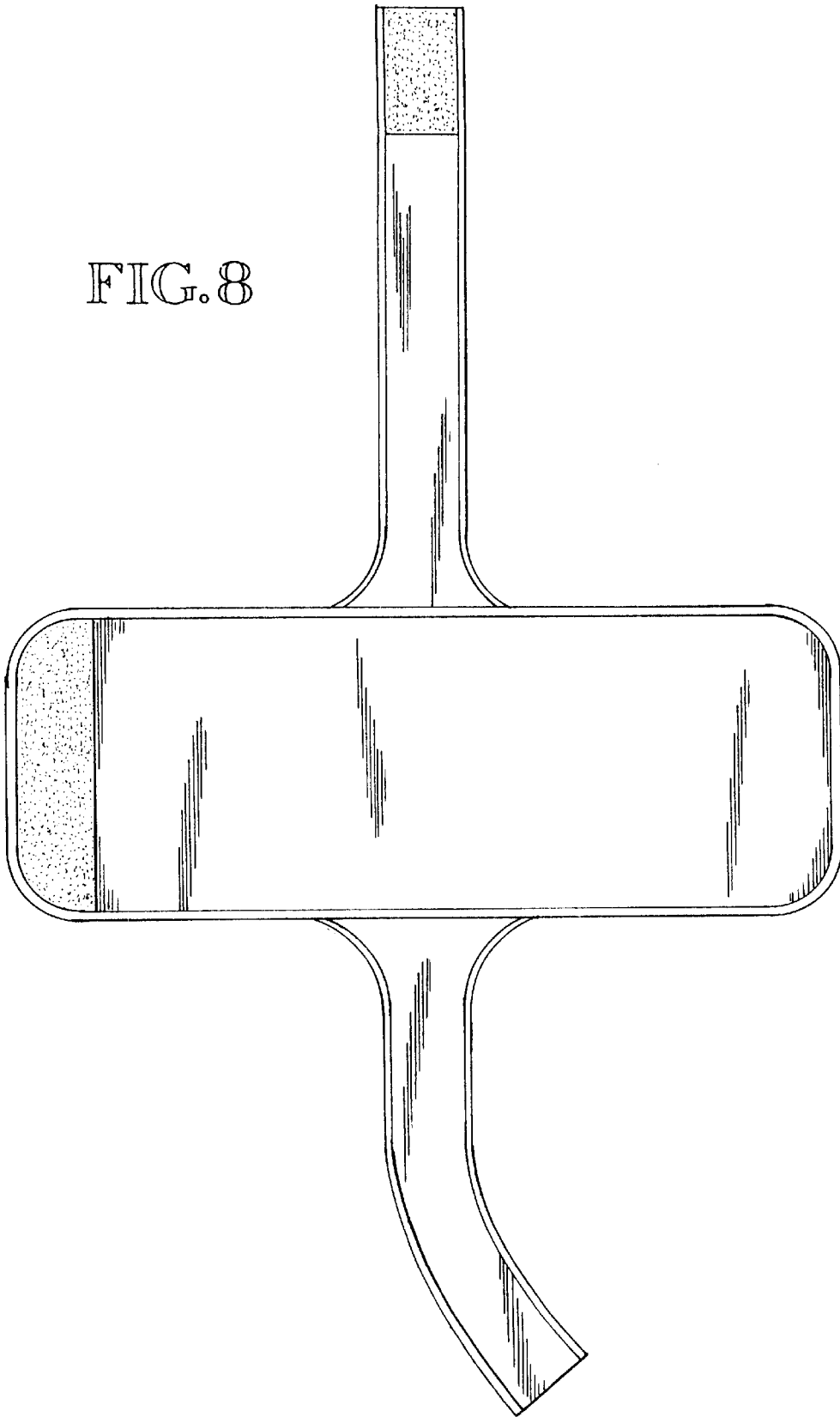

FIG. 8



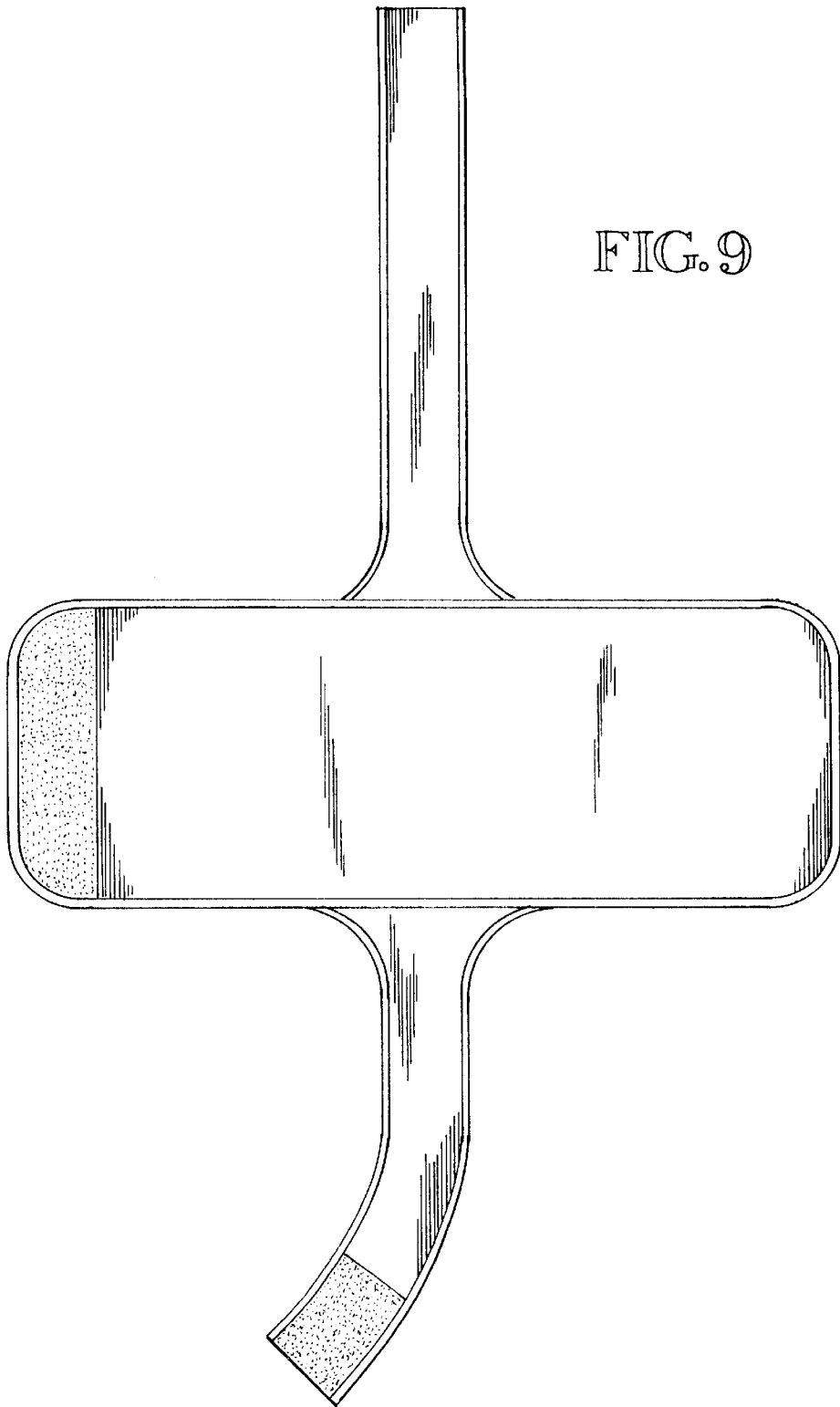

FIG. 9