

C. J. SAGEBRECHT.  
 PORTABLE ELECTRIC FLASH LIGHT.  
 APPLICATION FILED AUG. 22, 1914.

1,122,425.

Patented Dec. 29, 1914.

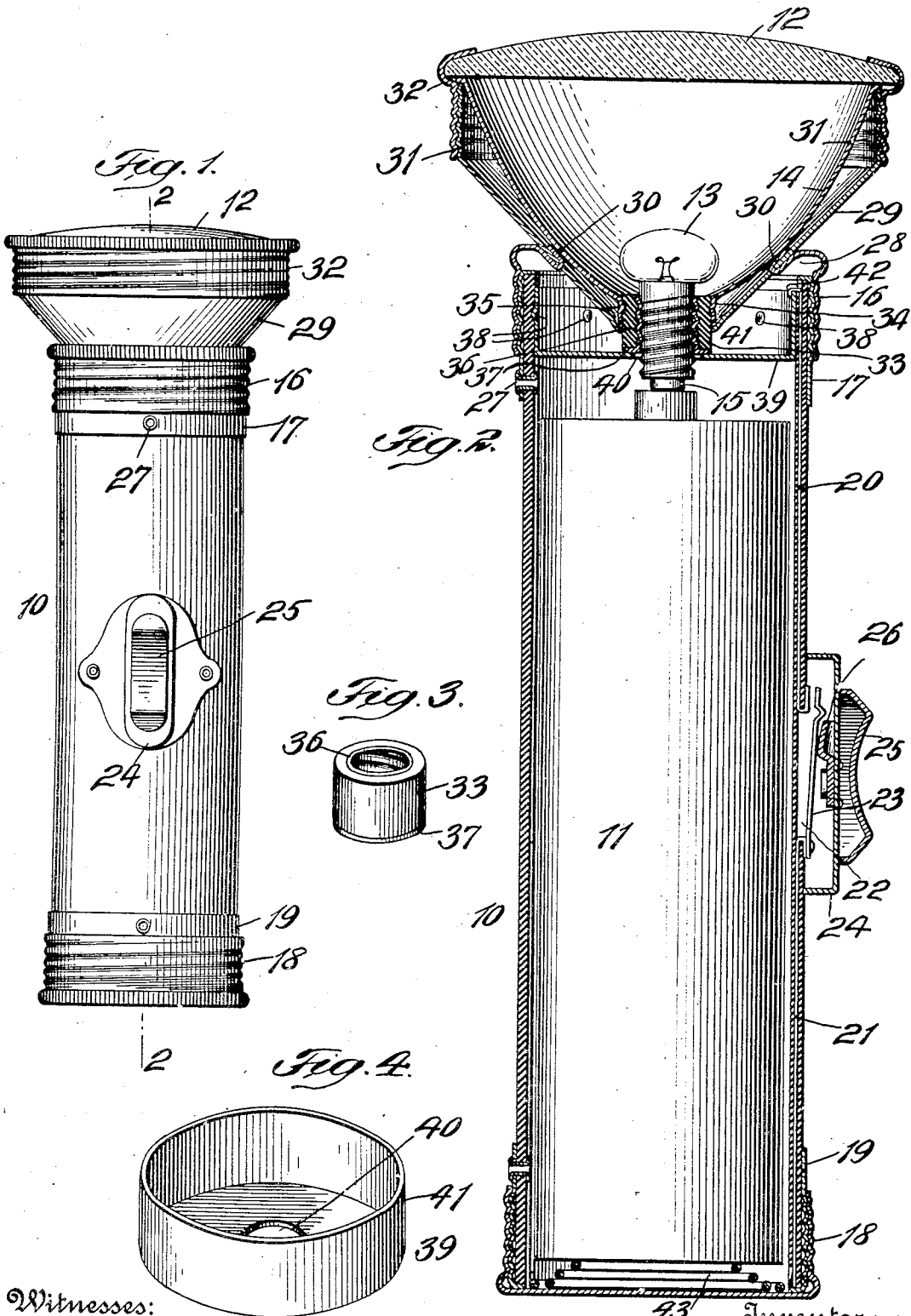

Witnesses:  
*Julius H. Smith*  
*Arthur M. Mason*

Inventor:  
 Charles J. Sagebrecht,  
 By his Attorney,  
 Charles C. Gill.

# UNITED STATES PATENT OFFICE.

CHARLES J. SAGEBRECHT, OF BROOKLYN, NEW YORK, ASSIGNOR TO INTERSTATE ELECTRIC NOVELTY CO., OF NEW YORK, N. Y., A CORPORATION OF NEW YORK.

## PORTABLE ELECTRIC FLASH-LIGHT.

1,122,425.

Specification of Letters Patent. Patented Dec. 29, 1914.

Application filed August 22, 1914. Serial No. 857,987.

*To all whom it may concern:*

Be it known that I, CHARLES J. SAGEBRECHT, a citizen of the United States, and a resident of Brooklyn, in the county of Kings and State of New York, have invented certain new and useful Improvements in Portable Electric Flash-Lights, of which the following is a specification.

The invention pertains more particularly to improvements in the class of electric lamps designed to be held in the hand and sometimes used as flash lights and at other times for affording a permanent light for a short period, and one object of the invention is to provide a novel and efficient construction of lamp of the class referred to with the parts so designed, arranged and combined that the circuit may not be closed by the placing of the electric lamp in a box of tools or against another electric lamp or against any body of conducting material which might connect the caps at the upper and lower ends of the usual electric lamp or flash light or connect the usual metal casing of the switch control mechanism with said upper cap on the casing. These flash lights are frequently carried by workmen in a box of tools, and it has frequently happened that some metal tool has by lying against the electric lamp completed the circuit through the battery, with the result that the lamp was lighted and the battery unnecessarily consumed.

In accordance with my invention I obviate the objection just referred to and provide a construction in which a metal tool lying against the side of the casing will be unable to complete the circuit.

I illustrate my invention as embodied in what is known as a miners' electric lamp or flash light, without intending to confine the invention in all its parts to a lamp or flash light of any particular denomination or intended for any particular use.

The invention will be fully understood from the detailed description hereinafter presented, reference being had to the accompanying drawings, in which:

Figure 1 is a side elevation of a portable electric lamp or flash light embodying my invention; Fig. 2 is a central vertical section, on a larger scale, through the same on the dotted line 2—2 of Fig. 1; Fig. 3 is a detached perspective view of a sleeve carried on the lower end of the reflector and having

a non-conducting outer body and a threaded conducting inner body adapted to receive the threaded stem of the lamp bulb, and Fig. 4 is a detached perspective view of a metal cup introduced into the upper end of the non-conducting main casing of the flash light and affording a support for the lower portion of the reflector and its co-acting parts carrying the lamp bulb.

In the drawings, 10 designates a paper or fiber casing for the lamp, 11 the battery therein, 12 the lens, 13 the electric lamp bulb, 14 the reflector, 15 the usual connection of the battery with the lamp, 16 an upper cap screwed upon a metal sleeve 17 which is fastened to the upper end of the casing and 18 a lower metal cap which is screwed upon a metal sleeve 19 fastened upon the lower end of the casing 10.

The casing 10 is equipped with two conductors or strips of metal 20, 21 which are to be placed in electrical connection with each other at their adjoining ends when the lamp is to be lighted, as hereinafter explained. The casing 10 is preferably formed from a spirally wound sheet of fiber, and the conductors 20, 21 in one continuous piece are wound within said sheet or placed in between the convolutions thereof during the formation of the tube or casing 10, and thereafter a recess 22 is formed in the outer wall of the casing 10 and the metal strip intended to form the conductors 20, 21 is severed thereat and a section of said strip removed therefrom, and thereupon the adjacent end portions of the sections of the strip constituting the conductors 20, 21 are bent outwardly upon the exterior surface of the casing 10, as shown in Fig. 2, so that the end of the conductor 21 may receive the spring switch 23 and the adjacent end of the conductor 20 adapted to receive at the proper time the free end of said switch. The recess 22 is covered over by an exterior metal casing 24 and upon this casing is placed a slide 25 carrying a metal projection 26 in engagement with the switch 23. When the slide 25 is in its inoperative position shown in Fig. 2, the free end of the switch 23 is out of engagement with the conductor 20, but when the slide 25 is moved upwardly on the casing 24, its projection 26 forces the switch 23 into engagement with the conductor 20 and completes the circuit through the lamp.

The sleeve 17 upon the upper end of the main casing 10 is of sheet metal and threaded and open at its upper end and at said end laps upon the upper edge of the casing 10. The sleeve 17 may be secured to the casing 10 by an eyelet or hollow rivet 27. The cap 16 is flanged inwardly and downwardly at its upper open end, as at 28, forming an annular seat for a metal shell 29, and said flange 28 at its inner lower edges is formed with a series of tongues 30 which are inserted through holes formed in said shell 29 and then bent upwardly against the inner surface of the same, these tongues serving to secure the shell against the cap 17 and so connecting the shell and cap that the two pieces may be handled as one. The shell 29 has an upper threaded annular portion 31 to receive the lens-holding ring 32, and thence said shell has its walls converge downwardly and inwardly defining approximately a cone-shape. The lower end of the shell 29 is open, and thereat snugly receives the exterior surface of a sleeve of insulating material 33 secured within a neck 34 depending from the lower end of the reflector 14. The sleeve 33 will preferably be formed of fiber and secured to the neck 34 by indentations 35 on said neck driven into the material of the sleeve 33. The reflector 14 has a flanged upper edge which rests upon the upper threaded portion 31 of the shell 29, and said reflector extends downwardly on converging lines within the shell 29 and holds within its aforesaid neck 34 the sleeve 33 which receives within it a threaded metal bushing or sleeve 36 having an outwardly flanged lower edge 37 and receiving the threaded stem of the lamp bulb 13, as shown in Fig. 2. The reflector 14, sleeve 33 of insulating material, and threaded metallic sleeve 36 are firmly united together so as to be handled as one piece.

Within the upper end of the outer casing 10 is secured by indentations or the like 38 a metallic cup 39 having an open center 40 in its bottom and vertical sides 41 closely fitting within the upper end of the casing 10. The side of the cap 39 has the upper end of the conductor 20 pinched over upon it, as at 42, and the bottom of said cup 39 is in contact with the lower flanged edge 37 of the sleeve 36. The sleeve of insulating material 33 insulates the lamp, the sleeve 36 and the cup 39 from the sleeve 16, casing 29 and reflector 14, and hence it will be seen that the circuit for the current, when the slide 25 is in its upper position, is through the conductor 20, cup 39, sleeve 36 and threaded socket of the lamp to the battery, the sleeve 16, casing 29, reflector 14 and sleeve 32 being insulated from outside of said circuit.

One of the main purposes of the invention

is to prevent a circuit through the lamp and battery being established by a tool or the like against which the slide 25 or casing 24 and sleeve 16 or casing 29 or sleeve 32 might be placed. In the construction presented the parts for the circuit are internal of the main casing 10, the sleeve 33 insulating the sleeve 16, casing 29, reflector 14 and sleeve 32 from the circuit. The casing 29 and sleeve 16 may be applied to the casing 10 as one piece; the reflector 14, sleeve 33 and sleeve 36 may be applied within the casing 10 as one piece and conveniently receive the lamp bulb, and thereupon the sleeve 32 may be applied to the upper portion of the casing 29 for securing the lens 12 in position.

The cap 18 at the lower end of the casing 10 is of usual construction, and within said cap is a conducting spring 43 of ordinary character in engagement with the lower end of the battery 11. The cap 18, sleeve 19 and spring 43 are in electrical connection with one another, and the sleeve 19 is in electrical connection with the conductor 21.

My invention resides in the special features provided at the upper end of the main casing 10 and particularly in the provision of the cup or the like 39 and reflector 14 having on its lower end the neck 34, insulating sleeve 33, and metal sleeve 36 to receive the lamp and enter into electrical engagement with the cup 39, which is in electrical connection with the conductor 20.

What I claim as my invention and desire to secure by Letters Patent, is:

1. A portable electric light of the class described comprising an exterior casing containing a battery, circuit terminal conductors extending along said casing and the lower one of which is in electrical connection with the battery, circuit closing means for connecting said conductors, a cup within the upper end of said casing having an open center and in electrical connection with the upper one of said conductors, a reflector having a neck containing a sleeve of non-conducting material mounted on a threaded sleeve of conducting material seated on said cup, a lamp whose stem is screwed within said threaded sleeve and extends through the opening of said cup to the battery, a lens, and means for securing the reflector and lens on said casing, said reflector and therewith said securing means being insulated from the lamp and battery by said nonconducting sleeve.

2. A portable electric light of the class described comprising an exterior casing containing a battery, circuit terminal conductors extending along said casing and the lower one of which is in electrical connection with the battery, circuit closing means for connecting said conductors, a cup within the upper end of said casing having an open center and in electrical connection

tion with the upper one of said conductors,  
 a reflector having a neck containing a  
 sleeve of non-conducting material mounted  
 on a threaded sleeve of conducting material  
 5 seated on said cup, a lamp whose stem is  
 screwed within said threaded sleeve and ex-  
 tends through the opening of said cup to  
 the battery, a lens, and means for securing  
 the reflector and lens on said casing, said  
 10 reflector and therewith said securing means  
 being insulated from the lamp and battery  
 by said nonconducting sleeve, and said se-  
 curing means comprising a threaded sleeve  
 on the said casing, a threaded cap on said  
 15 sleeve having an open center and flanged

inwardly and formed with tongues along its  
 opening, a shell of approximately inverted  
 cone-shape entering said cap and secured  
 thereto by said tongues and having an open  
 lower end exterior to said sleeve of non- 20  
 conducting material, and a threaded lens-  
 holding ring engaging the upper threaded  
 end of said shell and the edge of the lens.

Signed at Toronto, in the Province of  
 Ontario and Dominion of Canada this 19th 25  
 day of August, A. D. 1914.

CHARLES J. SAGEBRECHT.

Witnesses:

D. S. TOVELL,  
 W. G. GRAHAM.