

J. DONOVAN.
RAILWAY VELOCIPEDE.

No. 514,449.

Patented Feb. 13, 1894.

Fig. 3.

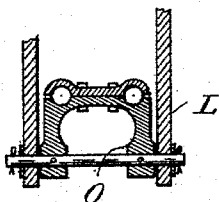

Fig. 2.

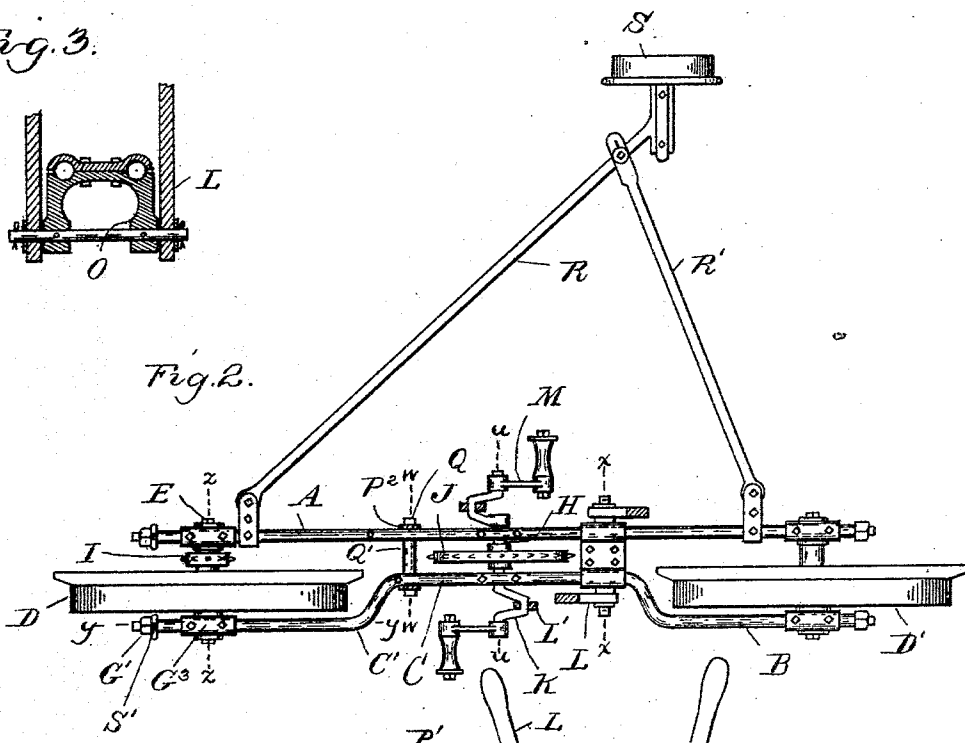
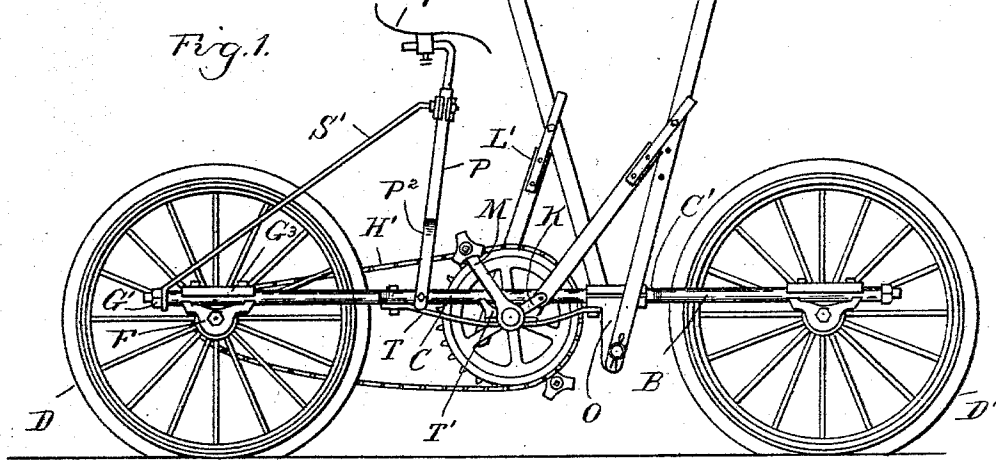

Fig. 1.



Witnesses
Ch. C. Kabbie
J. M. Fogarty

Inventor
James Donovan
By J. S. Maquet Son Atty's.

J. DONOVAN.
RAILWAY VELOCIPÈDE.

No. 514,449.

Patented Feb. 13, 1894.

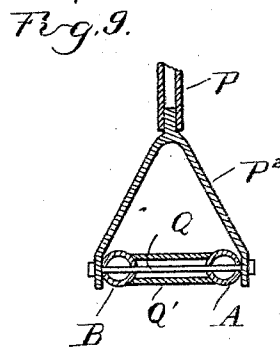
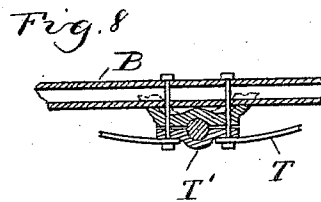
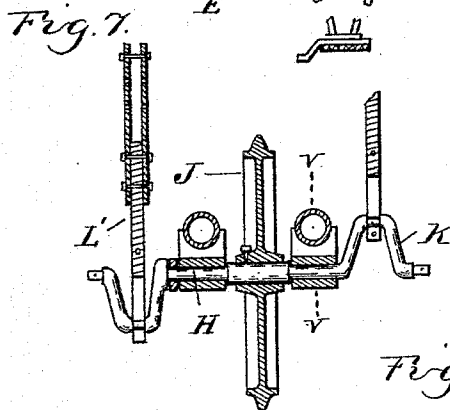
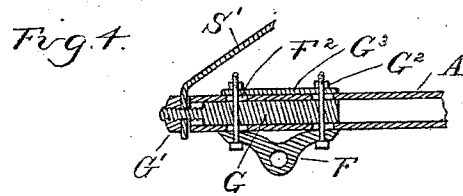
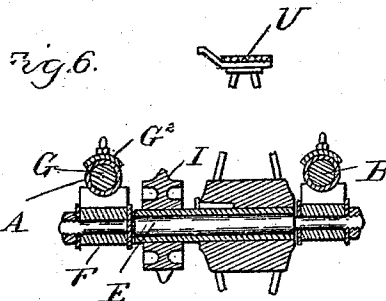
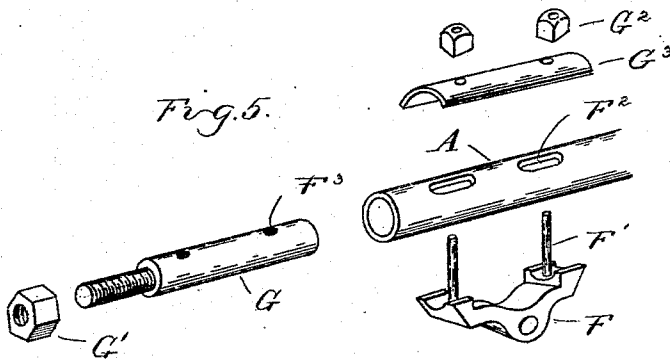

Witnesses
C. L. Fabbris
M. J. Maghera

Inventor
James Donovan
By M. J. Maghera
Atty.

UNITED STATES PATENT OFFICE.

JAMES DONOVAN, OF THREE RIVERS, MICHIGAN, ASSIGNOR TO THE ROBERTS, THROP & COMPANY, OF SAME PLACE.

RAILWAY-VELOCIPÈDE.

SPECIFICATION forming part of Letters Patent No. 514,449, dated February 13, 1894.

Application filed September 26, 1893. Serial No. 486,531. (No model.)

To all whom it may concern:

Be it known that I, JAMES DONOVAN, a citizen of the United States, residing at Three Rivers, in the county of St. Joseph and State of Michigan, have invented certain new and useful Improvements in Railway-Velocipedes, of which the following is a specification, reference being had therein to the accompanying drawings.

The invention consists in the peculiar construction of the frame, the seat support, the drive mechanism, and further in the peculiar construction, arrangement and combination of the various parts.

In the drawings, Figure 1 is a side elevation of my improved machine. Fig. 2 is a plan view thereof with the seat, and part of the driving gear removed. Fig. 3 is a vertical section on line *x x* Fig. 2. Fig. 4 is a longitudinal section on line *y y* Fig. 2. Fig. 5 is a perspective view of the parts shown in Fig. 4 detached. Fig. 6 is a section on line *z z* in Fig. 2. Fig. 7 is a section on line *u u* Fig. 2. Fig. 8 is a section on line *v v*, Fig. 7. Fig. 9 is a section on line *w w* Fig. 2.

My machine comprises a rigid frame supported by two track wheels in line, and an auxiliary wheel supported on a frame or outrigger, running on the opposite rail. The frame consists of the straight side bar A on the inside of the wheels and the side bar B on the outside of the wheels, the side bar B having the central offset section C between the wheels formed by the bends C', as plainly shown in Fig. 2.

D is the drive wheel and D' its companion wheel at the forward end of the frame. These wheels are journaled on shafts E, which serve as tie-rods to connect the ends of the frame together. The shafts E are supported in longitudinally adjustable boxes F on the frame. These boxes are provided with clamping bolts F' which pass through longitudinal slots F² in the side bars of the frame and through apertures F³ in adjusting bolts G which slidingly engage in the ends of the side bars, the side bars being tubular.

G' is a nut for adjusting the bolt G and G² are clamping nuts for clamping the boxes F in their adjusted positions. I preferably arrange a curved plate or washer G³ beneath the nuts G². This construction enables me to ad-

just the ends of the axle separately so as to perfectly align the wheels and at the same time to adjust the rear axle to and from the crank shaft H to tighten the drive chain H'. This drive chain passes over the sprocket pinion I, which is secured to the hub of the rear wheel or to a sleeve to which that hub is secured, as shown in Fig. 6, and over the sprocket wheel J on the drive shaft H. The drive shaft is journaled in boxes on the under side of the frame, centrally between the wheels and at its end is formed or provided with cranks K, by which power is applied through the hand levers L and connecting rods L'. At the ends of the cranks K are the pedal cranks M provided with suitable pedals and adapted for foot propulsion, the four cranks being set at quarters around the drive shaft. The handle levers L are journaled at the lower end of a bracket O depending below the frame and serving as a tie for the side bars in rear of the front wheels.

P is a saddle post carrying at its upper end a suitable saddle P' and at its lower end bifurcated, as shown in Fig. 9, the bifurcations P² extending to each side of the frame, being secured in position by the clamping bolt Q, which at the same time acts as a tie for the side bars of the frame in front of the rear wheel, and which are spaced apart by the sleeve Q' between the side bars, through which the bolt passes.

The outrigger consists of the two braces R R' secured respectively to opposite ends of the inner side bar and adjustably secured together near their outer ends, one of the bars carrying the flanged guide wheel S journaled on a suitable stub shaft. It will be observed that the weight of the rider is sustained upon the inner side bar and the offset section C of the outside side bar, which brings nearly his entire weight inside the frame and still supporting it upon the frame. Supporting the weight of the rider on the frame enables me to use a light outrigger, and bringing his weight inside of the wheels prevents danger of accident in going around curves.

The saddle post I preferably brace by means of braces S' extending to the ends of the side bars and secured in position by the clamping bolts G'.

The central section of the frame I truss by

means of truss rods T made in sections having their inner ends connected to the box T', in which the crank shaft is journaled, as plainly shown in Fig. 8, the outer ends of the sections being attached to the under side of the side bars by suitable bolts, as shown in Fig. 1. This construction of crank enables me to apply power by both hands and feet.

Many accidents happen in the use of railway velocipedes from the fact that the noise which the wheels make upon the rails prevents the rider from hearing an approaching train until too late to escape. To overcome this difficulty and to make the wheels noiseless I apply with cement or in any other suitable manner to the rim of the wheel a non-metallic covering U extending from the outer edge of the wheel rim to the edge of the flange and forming the tread of the wheel. This strip or band I preferably make of canvas and rubber substantially like rubber belting.

I have found in use that the only noise which such a velocipede will make will be the noise due to the touching of the wheel flange upon the inner face of the rail, the velocipede going practically noiselessly.

What I claim as my invention is—

1. In a railway velocipede, the combination with the wheels, of a frame supported on the wheels composed of a straight inner bar and an outer bar, the outer bar having a central section bent inwardly between the wheels, and a seat supported on both bars, substantially as described.

2. In a railway velocipede, the combination with the frame comprising a straight inner bar and an inwardly bent outer bar forming a central offset portion, of shafts connecting the ends of the frame, wheels journaled on the shafts, and tie rods connecting the inner bar with the central offset portion of the outer bar, substantially as described.

3. In a railway velocipede, the combination

with the frame comprising a straight inner bar and an inwardly bent outer bar forming a central offset portion, of shafts connecting the ends of the frame, wheels journaled on the shafts, tie rods connecting the inner bar with the central offset portion of the outer bar, and spacing blocks on the tie rods between the bars, substantially as described.

4. In a railway velocipede, the combination of the wheeled frame composed of tubular side bars tied together, of axles supporting the wheels, boxes on the frame in which said axles engage, a slotted bearing in the ends of the side bars, clamping bolts on the boxes engaging through said slots, and adjusting bolts in the ends of the bars, through which said bolts pass, substantially as described.

5. In a railway velocipede, the combination with the wheels and frame, of a drive mechanism comprising a shaft having U-cranks on its opposite ends between the ends and center, hand levers connected to the cranks, crank arms fixed to the outer ends of the shaft beyond the cranks, and arranged at an angle to the cranks, and pedals on the crank arms, substantially as described.

6. In a railway velocipede, the combination of the wheeled frame composed of tubular side bars tied together, of axles supporting the wheels, boxes on the frame in which said axles engage, a slotted bearing in the ends of the side bars, clamping bolts on the boxes engaging through said slots adjusting bolts in the ends of the bars through which said bolts pass, nuts on the end of the clamping bolts, and curved washers between the nuts and side bars, substantially as described.

In testimony whereof I affix my signature in presence of two witnesses.

JAMES DONOVAN.

Witnesses:

JAMES E. BUNN,

MARVIN H. BUMPHEY.