

(19)



Europäisches Patentamt

European Patent Office

Office européen des brevets



(11)

**EP 0 765 236 B1**

(12)

**EUROPEAN PATENT SPECIFICATION**

(45) Date of publication and mention of the grant of the patent:  
**28.07.1999 Bulletin 1999/30**

(51) Int. Cl.<sup>6</sup>: **B41J 2/065**, B41J 2/04,  
B41J 2/005

(21) Application number: **96912633.3**

(86) International application number:  
**PCT/US96/04854**

(22) Date of filing: **09.04.1996**

(87) International publication number:  
**WO 96/32277 (17.10.1996 Gazette 1996/46)**

**(54) COINCIDENT DROP SELECTION, DROP SEPARATION PRINTING SYSTEM**

DRUCKSYSTEM MIT KOINZIDIERENDER TROPFENAUSWAHL UND TROPFENTRENNUNG  
SYSTEME D'IMPRESSION A SELECTION ET SEPARATION CONCOMITANTES DES  
GOUTTELETTES

(84) Designated Contracting States:  
**DE FR GB IT**

(56) References cited:

(30) Priority: **12.04.1995 AU PN230995**  
**12.04.1995 AU PN232295**  
**12.04.1995 AU PN232395**

<b>EP-A- 0 336 043</b>	<b>EP-A- 0 400 955</b>
<b>EP-A- 0 493 102</b>	<b>EP-A- 0 550 148</b>
<b>EP-A- 0 600 712</b>	<b>WO-A-90/14233</b>
<b>DE-A- 2 949 808</b>	<b>US-A- 3 916 419</b>
<b>US-A- 4 164 745</b>	<b>US-A- 4 293 865</b>
<b>US-A- 4 312 009</b>	<b>US-A- 4 561 789</b>
<b>US-A- 4 737 803</b>	<b>US-A- 4 752 784</b>
<b>US-A- 5 305 016</b>	

(43) Date of publication of application:  
**02.04.1997 Bulletin 1997/14**

(73) Proprietor:  
**EASTMAN KODAK COMPANY**  
**Rochester, New York 14650-2201 (US)**

- **PATENT ABSTRACTS OF JAPAN vol. 010, no. 066 (M-461), 15 March 1986 & JP,A,60 210462 (FUJI XEROX KK), 22 October 1985,**
- **PATENT ABSTRACTS OF JAPAN vol. 011, no. 131 (M-584), 24 April 1987 & JP,A,61 272161 (NEC CORP), 2 December 1986,**
- **PATENT ABSTRACTS OF JAPAN vol. 009, no. 215 (M-409), 3 September 1985 & JP,A,60 076350 (CANON KK), 30 April 1985,**
- **PATENT ABSTRACTS OF JAPAN vol. 012, no. 437 (M-765), 17 November 1988 & JP,A,63 172658 (FUJITSU LTD), 16 July 1988,**
- **IBM TECHNICAL DISCLOSURE BULLETIN, vol. 13, no. 5, October 1970, NEW YORK US, pages 1131-1132, XP002006675 E. C. GREANIAS: "Hydraulic-electrostatic printer"**

(72) Inventor:  
**SILVERBROOK, Kia,**  
**c/o Eastman Kodak Company**  
**Rochester, NY 14650-2201 (US)**

(74) Representative:  
**Reichert, Werner Franz, Dr.**  
**Kodak Aktiengesellschaft,**  
**Patent Department**  
**70323 Stuttgart (DE)**

**EP 0 765 236 B1**

Note: Within nine months from the publication of the mention of the grant of the European patent, any person may give notice to the European Patent Office of opposition to the European patent granted. Notice of opposition shall be filed in a written reasoned statement. It shall not be deemed to have been filed until the opposition fee has been paid. (Art. 99(1) European Patent Convention).

**Description**Field of the Invention

5 **[0001]** The present invention is in the field of computer controlled printing devices. In particular, the field is liquid ink drop on demand (DOD) printing systems.

Background of the Invention

10 **[0002]** Many different types of digitally controlled printing systems have been invented, and many types are currently in production. These printing systems use a variety of actuation mechanisms, a variety of marking materials, and a variety of recording media. Examples of digital printing systems in current use include: laser electrophotographic printers; LED electrophotographic printers; dot matrix impact printers; thermal paper printers; film recorders; thermal wax printers; dye diffusion thermal transfer printers; and ink jet printers. However, at present, such electronic printing systems  
15 have not significantly replaced mechanical printing presses, even though this conventional method requires very expensive setup and is seldom commercially viable unless a few thousand copies of a particular page are to be printed. Thus, there is a need for improved digitally controlled printing systems, for example, being able to produce high quality color images at a high-speed and low cost, using standard paper.

20 **[0003]** Inkjet printing has become recognized as a prominent contender in the digitally controlled, electronic printing arena because, e.g., of its non-impact, low-noise characteristics, its use of plain paper and its avoidance of toner transfers and fixing.

**[0004]** Many types of ink jet printing mechanisms have been invented. These can be categorized as either continuous ink jet (CIJ) or drop on demand (DOD) ink jet. Continuous ink jet printing dates back to at least 1929: Hansell, US Pat. No. 1,941,001.

25 **[0005]** Sweet et al US Pat. No. 3,373,437, 1967, discloses a array of continuous ink jet nozzles where ink drops to be printed are selectively charged and deflected towards the recording medium. This technique is known as binary deflection CIJ, and is used by several manufacturers, including Elmjet and Scitex.

**[0006]** Hertz et al US Pat. No. 3,416,153, 1966, discloses a method of achieving variable optical density of printed spots in CIJ printing using the electrostatic dispersion of a charged drop stream to modulate the number of droplets  
30 which pass through a small aperture. This technique is used in ink jet printers manufactured by Iris Graphics.

**[0007]** Kyser et al US Pat. No. 3,946,398, 1970, discloses a DOD ink jet printer which applies a high voltage to a piezoelectric crystal, causing the crystal to bend, applying pressure on an ink reservoir and jetting drops on demand. Many types of piezoelectric drop on demand printers have subsequently been invented, which utilize piezoelectric crystals in bend mode, push mode, shear mode, and squeeze mode. Piezoelectric DOD printers have achieved commercial success using hot melt inks (for example, Tektronix and Dataproducts printers), and at image resolutions up to 720 dpi for home and office printers (Seiko Epson). Piezoelectric DOD printers have a advantage in being able to use a wide range  
35 of inks. However, piezoelectric printing mechanisms usually require complex high voltage drive circuitry and bulky piezoelectric crystal arrays, which are disadvantageous in regard to manufacturability and performance.

**[0008]** Endo et al GB Pat. No. 2,007,162, 1979, discloses a electrothermal DOD ink jet printer which applies a power pulse to an electrothermal transducer (heater) which is in thermal contact with ink in a nozzle. The heater rapidly heats water based ink to a high temperature, whereupon a small quantity of ink rapidly evaporates, forming a bubble. The formation of these bubbles results in a pressure wave which cause drops of ink to be ejected from small apertures along the edge of the heater substrate. This technology is known as Bubblejet™ (trademark of Canon K.K. of Japan), and is used in a wide range of printing systems from Canon, Xerox, and other manufacturers.

45 **[0009]** Vaught et al US Pat. No. 4,490,728, 1982, discloses an electrothermal drop ejection system which also operates by bubble formation. In this system, drops are ejected in a direction normal to the plane of the heater substrate, through nozzles formed in an aperture plate positioned above the heater. This system is known as Thermal Ink Jet, and is manufactured by Hewlett-Packard. In this document, the term Thermal Ink Jek is used to refer to both the Hewlett-Packard system and systems commonly known as Bubblejet™.

50 **[0010]** Thermal Ink Jet printing typically requires approximately 20 μJ over a period of approximately 2 μs to eject each drop. The 10 Watt active power consumption of each heater is disadvantageous in itself and also necessitates special inks, complicates the driver electronics and precipitates deterioration of heater elements.

**[0011]** Other ink jet printing systems have also been described in technical literature, but are not currently used on a commercial basis. For example, U.S. Patent No. 4,275,290 discloses a system wherein the coincident address of pre-determined print head nozzles with heat pulses and hydrostatic pressure, allows ink to flow freely to spacer-separated paper, passing beneath the print head. U.S. Patent Nos. 4,737,803; 4,737,803 and 4,748,458 disclose ink jet recording systems wherein the coincident address of ink in print head nozzles with heat pulses and an electrostatically attractive field cause ejection of ink drops to a print sheet

**[0012]** Each of the above-described inkjet printing systems has advantages and disadvantages. However, there remains a widely recognized need for an improved ink jet printing approach, providing advantages for example, as to cost, speed, quality, reliability, power usage, simplicity of construction and operation, durability and consumables.

#### 5 Summary of the invention

**[0013]** My concurrently filed application, entitled "A Liquid Ink Printing Apparatus and System" and describes new methods and apparatus that afford significant improvements toward overcoming the prior art problems discussed above. Those inventions offer important advantages, e.g., in regard to drop size and placement accuracy, as to printing speeds attainable, as to power usage, as to durability and operative thermal stresses encountered and as to other printer performance characteristics, as well as in regard to manufacturability and the characteristics of useful inks. One important purpose of the present invention is to further enhance the structures and methods described in that patent applications and thereby contribute to the advancement of printing technology.

**[0014]** Thus, one significant object of the present invention is to provide new methods of drop on demand ink printing that are improved in regard to prior approaches. In important aspects, the methods of this invention offer advantages as to drop size and placement accuracy, as to printing speed, as to power usage, as to durability and operative thermal stresses and to various other printing performance characteristics noted in more detail hereinafter. In other important aspects, the present invention offers significant advantages as to manufacture and as to the nature of its useful inks.

**[0015]** The present invention is defined in the appended claims.

**[0016]** In one constitution, the present invention comprises a method of drop on demand printing including the steps of (1) addressing the ink in selected nozzles of a print head with the coincident forces of (a) above ambient manifold pressure and (b) a selection energy pulse that, in combined effects, are sufficient to cause addressed ink portions to move out of their related nozzle to a predetermined region, beyond the ink in non-selected nozzles, but not so far as to separate from their contiguous ink mass; and (2) during such addressing step, attracting ink from the print head toward a print zone with forces of magnitude and proximity that (a) cause the selected ink moved into said region to separate from its contiguous ink mass and (b) do not cause non-addressed ink to so separate.

**[0017]** In certain preferred embodiments, the drop selecting means comprises heating ink to reduce surface tension in coincidence with above ambient air pressure application to the ink. In further preferred embodiments, drop separation means include predetermined ink conductivity characteristics in combination with predetermined uniform electric fields.

**[0018]** In another preferred aspect, the present invention comprises a thermally activated liquid ink printing head being characterized by the energy required to eject a drop of ink being less than the energy required to raise the temperature of the bulk ink of a volume equal to the volume of said ink drop above the ambient ink temperature to a temperature which is below the drop ejection temperature.

**[0019]** In another preferred aspect, the present invention comprises a thermally activated drop on demand printer wherein ink utilized is solid at room temperature, but liquid at operating temperature and selection means comprise coincidence of varying pressure pulses and selected heating to reduce the viscosity of ink in the vicinity of drops to be selected.

**[0020]** In yet another aspect, the invention provides a thermally activated liquid ink printing head being characterized by the energy required to eject a drop of ink being less than the energy required to raise the temperature of the bulk ink of a volume equal to the volume of the ink drop above the ambient ink temperature to a temperature which is below the drop ejection temperature.

#### Brief Description of the Drawings

**[0021]**

Figure 1(a) shows a simplified block schematic diagram of one exemplary printing apparatus according to the present invention.

Figure 1(b) shows a cross section of one variety of nozzle tip in accordance with the invention.

Figures 2(a) to 2(f) show fluid dynamic simulations of drop selection.

Figure 2(g) shows fluid streamlines 50 microseconds after the beginning of the drop selection heater pulse.

Figure 3(a) shows successive meniscus positions at intervals during a drop selection cycle.

Figure 3(b) is a graph of meniscus position versus time during a heating pulse.

Figure 3(c) shows the temperatures at various points during a drop selection cycle.

Figure 3(d) shows measured surface tension versus temperature curves for various ink additives.

Figure 3(e) shows the power pulses which are applied to the nozzle heater to generate the temperature curves of figure 3(c)

Figure 4 shows a block schematic diagram of print head drive circuitry for practice of the invention. Figure 5 shows

projected manufacturing yields for an A4 page width color print head embodying features of the invention, with and without fault tolerance.

Figure 6(a) shows a generalized block diagram of a printing system using one embodiment of the present invention. Figure 6(b) shows a cross section of an example print head nozzle embodiment of the invention.

Figure 7 shows three cycles of pressure oscillation as a function of time.

Figure 8 shows the temperature at various points in the nozzle as a function of time, with an electrothermal pulse applied during the third cycle of Figure 7.

Figure 9 shows the position of the meniscus extremum as a function of time during the period of Figure 7.

Figure 10(a), 10(c), 10(e), 10(g) and 10(i) show thermal contours and drop evolution at various times during a drop ejection cycle.

Figure 10(b), 10(d), 10(f), 10(h) and 10(j) show viscosity contours and drop evolution at various times during a drop ejection cycle.

Figure 11 shows the movement of meniscus position during a cycle when the ink drop is not selected.

Figure 12 shows the movement of meniscus position during a drop selection cycle. Drop separation is not shown.

Figure 13 shows the position of the meniscus extremum as a function of time for a print head operating at half the frequency of the print head in Figures 7 to 12.

Figure 14 shows the movement of meniscus position during a cycle when the ink drop is not selected in a print head operating at half the frequency of the print head in Figures 7 to 12.

Figure 15 shows the movement of meniscus position during a drop selection cycle in a print head operating at half the frequency of the print head in Figures 7 to 12. Drop separation is not shown.

Detailed Description of Preferred Embodiments

[0022] In one general aspect, the invention constitutes a drop-on-demand printing mechanism wherein the means of selecting drops to be printed produces a difference in position between selected drops and drops which are not selected, but which is insufficient to cause the ink drops to overcome the ink surface tension and separate from the body of ink, and wherein an alternative means is provided to cause separation of the selected drops from the body of ink.

[0023] The separation of drop selection means from drop separation means significantly reduces the energy required to select which ink drops are to be printed. Only the drop selection means must be driven by individual signals to each nozzle. The drop separation means can be a field or condition applied simultaneously to all nozzles.

[0024] The drop selection means may be chosen from, but is not limited to, the following list:

- 1) Electrothermal reduction of surface tension of pressurized ink
- 2) Electrothermal bubble generation, with insufficient bubble volume to cause drop ejection
- 3) Piezoelectric, with insufficient volume change to cause drop ejection
- 4) Electrostatic attraction with one electrode per nozzle

[0025] The drop separation means may be chosen from, but is not limited to, the following list:

- 1) Proximity (recording medium in close proximity to print head)
- 2) Proximity with oscillating ink pressure
- 3) Electrostatic attraction
- 4) Magnetic attraction

[0026] The table "DOD printing technology targets" shows some desirable characteristics of drop on demand printing technology. The table also lists some methods by which some embodiments described herein, or in other of my related applications, provide improvements over the prior art.

<i>DOD printing technology targets</i>	
<b>Target</b>	<b>Method of achieving improvement over prior art</b>
<b>High speed operation</b>	Practical, low cost, pagewidth printing heads with more than 10,000 nozzles. Monolithic A4 pagewidth print heads can be manufactured using standard 300 mm (12") silicon wafers

(continued)

<i>DOD printing technology targets</i>	
<b>Target</b>	<b>Method of achieving improvement over prior art</b>
5 <b>High image quality</b>	High resolution (800 dpi is sufficient for most applications), six color process to reduce image noise
<b>Full color operation</b>	Halftoned process color at 800 dpi using stochastic screening
10 <b>Ink flexibility</b>	Low operating ink temperature and no requirement for bubble formation
<b>Low power requirements</b>	Low power operation results from drop selection means not being required to fully eject drop
15 <b>Low cost</b>	Monolithic print head without aperture plate, high manufacturing yield, small number of electrical connections, use of modified existing CMOS manufacturing facilities
<b>High manufacturing yield</b>	Integrated fault tolerance in printing head
20 <b>High reliability</b>	Integrated fault tolerance in printing head. Elimination of cavitation and kogation. Reduction of thermal shock.
<b>Small number of electrical connections</b>	Shift registers, control logic, and drive circuitry can be integrated on a monolithic print head using standard CMOS processes
25 <b>Use of existing VLSI manufacturing facilities</b>	CMOS compatibility. This can be achieved because the heater drive power is less than 1% of Thermal Ink Jet heater drive power
30 <b>Electronic collation</b>	A new page compression system which can achieve 100:1 compression with insignificant image degradation, resulting in a compressed data rate low enough to allow real-time printing of any combination of thousands of pages stored on a low cost magnetic disk drive.

[0027] In thermal ink jet (TIJ) and piezoelectric ink jet systems, a drop velocity of approximately 10 meters per second is preferred to ensure that the selected ink drops overcome ink surface tension, separate from the body of the ink, and strike the recording medium. These systems have a very low efficiency of conversion of electrical energy into drop kinetic energy. The efficiency of TIJ systems is approximately 0.02%). This means that the drive circuits for TIJ print heads must switch high currents. The drive circuits for piezoelectric ink jet heads must either switch high voltages, or drive highly capacitive loads. The total power consumption of pagewidth TIJ printheads is also very high. An 800 dpi A4 full color pagewidth TIJ print head printing a four color black image in one second would consume approximately 6 kW of electrical power, most of which is converted to waste heat. The difficulties of removal of this amount of heat precludes the production of low cost, high speed, high resolution compact pagewidth TIJ systems.

[0028] One important feature of embodiments of the invention is a means of significantly reducing the energy required to select which ink drops are to be printed. This is achieved by separating the means for selecting ink drops from the means for ensuring that selected drops separate from the body of ink and form dots on the recording medium. Only the drop selection means must be driven by individual signals to each nozzle. The drop separation means can be a field or condition applied simultaneously to all nozzles.

[0029] The table "Drop selection means" shows some of the possible means for selecting drops in accordance with the invention. The drop selection means is only required to create sufficient change in the position of selected drops that the drop separation means can discriminate between selected and unselected drops.

Drop selection means

Method	Advantage	Limitation
1. Electrothermal reduction of surface tension of pressurized ink	Low temperature increase and low drop selection energy. Can be used with many ink types. Simple fabrication. CMOS drive circuits can be fabricated on same substrate	Requires ink pressure regulating mechanism. Ink surface tension must reduce substantially as temperature increases
2. Electrothermal reduction of ink viscosity, combined with oscillating ink pressure	Medium drop selection energy, suitable for hot melt and oil based inks. Simple fabrication. CMOS drive circuits can be fabricated on same substrate	Requires ink pressure oscillation mechanism. Ink must have a large decrease in viscosity as temperature increases
3. Electrothermal bubble generation, with insufficient bubble volume to cause drop ejection	Well known technology, simple fabrication, bipolar drive circuits can be fabricated on same substrate	High drop selection energy, requires water based ink, problems with kogation, cavitation, thermal stress
4. Piezoelectric, with insufficient volume change to cause drop ejection	Many types of ink base can be used	High manufacturing cost, incompatible with integrated circuit processes, high drive voltage, mechanical complexity, bulky
5. Electrostatic attraction with one electrode per nozzle	Simple electrode fabrication	Nozzle pitch must be relatively large. Crosstalk between adjacent electric fields. Requires high voltage drive circuits

[0030] Other drop selection means may also be used.

[0031] The preferred drop selection means for water based inks is method 1: "Electrothermal reduction of surface tension of pressurized ink". This drop selection means provides many advantages over other systems, including; low power operation (approximately 1% of TIJ), compatibility with CMOS VLSI chip fabrication, low voltage operation (approx. 10 V), high nozzle density, low temperature operation, and wide range of suitable ink formulations. The ink must exhibit a reduction in surface tension with increasing temperature.

[0032] The preferred drop selection means for hot melt or oil based inks is method 2: "Electrothermal reduction of ink viscosity, combined with oscillating ink pressure". This drop selection means is particularly suited for use with inks which exhibit a large reduction of viscosity with increasing temperature, but only a small reduction in surface tension. This occurs particularly with non-polar ink carriers with relatively high molecular weight. This is especially applicable to hot melt and oil based inks.

[0033] The table "Drop separation means" shows some of the possible methods for separating selected drops from the body of ink, and ensuring that the selected drops form dots on the printing medium. The drop separation means discriminates between selected drops and unselected drops to ensure that unselected drops do not form dots on the printing medium.

Drop separation means

Means	Advantage	Limitation
1. Electrostatic attraction	Can print on rough surfaces, simple implementation	Requires high voltage power supply

(continued)

<i>Drop separation means</i>		
<b>Means</b>	<b>Advantage</b>	<b>Limitation</b>
5 <b>2. AC electric field</b>	Higher field strength is possible than electrostatic, operating margins can be increased, ink pressure reduced, and dust accumulation is reduced	Requires high voltage AC power supply synchronized to drop ejection phase. Multiple drop phase operation is difficult
10 <b>3. Proximity (print head in close proximity to, but not touching, recording medium)</b>	Very small spot sizes can be achieved. Very low power dissipation. High drop position accuracy	Requires print medium to be very close to print head surface, not suitable for rough print media, usually requires transfer roller or belt
15 <b>4. Transfer Proximity (print head is in close proximity to a transfer roller or belt)</b>	Very small spot sizes can be achieved, very low power dissipation, high accuracy, can print on rough paper	Not compact due to size of transfer roller or transfer belt.
20 <b>5. Proximity with oscillating ink pressure</b>	Useful for hot melt inks using viscosity reduction drop selection method, reduces possibility of nozzle clogging, can use pigments instead of dyes	Requires print medium to be very close to print head surface, not suitable for rough print media. Requires ink pressure oscillation apparatus
25 <b>6. Magnetic attraction</b>	Can print on rough surfaces. Low power if permanent magnets are used	Requires uniform high magnetic field strength, requires magnetic ink

[0034] Other drop separation means may also be used.

[0035] The preferred drop separation means depends upon the intended use. For most applications, method 1: "Electrostatic attraction", or method 2: "AC electric field" are most appropriate. For applications where smooth coated paper or film is used, and very high speed is not essential, method 3: "Proximity" may be appropriate. For high speed, high quality systems, method 4: "Transfer proximity" can be used. Method 6: "Magnetic attraction" is appropriate for portable printing systems where the print medium is too rough for proximity printing, and the high voltages required for electrostatic drop separation are undesirable. There is no clear 'best' drop separation means which is applicable to all circumstances.

[0036] A simplified schematic diagram of one preferred printing system according to the invention appears in Figure 1(a).

[0037] An image source 52 may be raster image data from a scanner or computer, or outline image data in the form of a page description language (PDL), or other forms of digital image representation. This image data is converted to a pixel-mapped page image by the image processing system 53. This may be a raster image processor (RIP) in the case of PDL image data, or may be pixel image manipulation in the case of raster image data. Continuous tone data produced by the image processing unit 53 is halftoned. Halftoning is performed by the Digital Halftoning unit 54. Halftoned bitmap image data is stored in the image memory 72. Depending upon the printer and system configuration, the image memory 72 may be a full page memory, or a band memory. Heater control circuits 71 read data from the image memory 72 and apply time-varying electrical pulses to the nozzle heaters (103 in figure 1(b)) that are part of the print head 50. These pulses are applied at an appropriate time, and to the appropriate nozzle, so that selected drops will form spots on the recording medium 51 in the appropriate position designated by the data in the image memory 72.

[0038] The recording medium 51 is moved relative to the head 50 by a paper transport system 65, which is electronically controlled by a paper transport control system 66, which in turn is controlled by a microcontroller 315. The paper transport system shown in figure 1(a) is schematic only, and many different mechanical configurations are possible. In the case of pagewidth print heads, it is most convenient to move the recording medium 51 past a stationary head 50. However, in the case of scanning print systems, it is usually most convenient to move the head 50 along one axis (the sub-scanning direction) and the recording medium 51 along the orthogonal axis (the main scanning direction), in a relative raster motion. The microcontroller 315 may also control the ink pressure regulator 63 and the heater control circuits 71.

[0039] For printing using surface tension reduction, ink is contained in an ink reservoir 64 under pressure. In the quiescent state (with no ink drop ejected), the ink pressure is insufficient to overcome the ink surface tension and eject a drop. A constant ink pressure can be achieved by applying pressure to the ink reservoir 64 under the control of an ink pressure regulator 63. Alternatively, for larger printing systems, the ink pressure can be very accurately generated and

controlled by situating the top surface of the ink in the reservoir 64 an appropriate distance above the head 50. This ink level can be regulated by a simple float valve (not shown).

[0040] For printing using viscosity reduction, ink is contained in an ink reservoir 64 under pressure, and the ink pressure is caused to oscillate. The means of producing this oscillation may be a piezoelectric actuator mounted in the ink channels (not shown).

[0041] When properly arranged with the drop separation means, selected drops proceed to form spots on the recording medium 51, while unselected drops remain part of the body of ink.

[0042] The ink is distributed to the back surface of the head 50 by an ink channel device 75. The ink preferably flows through slots and/or holes etched through the silicon substrate of the head 50 to the front surface, where the nozzles and actuators are situated. In the case of thermal selection, the nozzle actuators are electrothermal heaters.

[0043] In some types of printers according to the invention, an external field 74 is required to ensure that the selected drop separates from the body of the ink and moves towards the recording medium 51. A convenient external field 74 is a constant electric field, as the ink is easily made to be electrically conductive. In this case, the paper guide or platen 67 can be made of electrically conductive material and used as one electrode generating the electric field. The other electrode can be the head 50 itself. Another embodiment uses proximity of the print medium as a means of discriminating between selected drops and unselected drops.

[0044] For small drop sizes gravitational force on the ink drop is very small; approximately  $10^{-4}$  of the surface tension forces, so gravity can be ignored in most cases. This allows the print head 50 and recording medium 51 to be oriented in any direction in relation to the local gravitational field. This is an important requirement for portable printers.

[0045] Figure 1(b) is a detail enlargement of a cross section of a single microscopic nozzle tip embodiment of the invention, fabricated using a modified CMOS process. The nozzle is etched in a substrate 101, which may be silicon, glass, metal, or any other suitable material. If substrates which are not semiconductor materials are used, a semiconducting material (such as amorphous silicon) may be deposited on the substrate, and integrated drive transistors and data distribution circuitry may be formed in the surface semiconducting layer. Single crystal silicon (SCS) substrates have several advantages, including:

- 1) High performance drive transistors and other circuitry can be fabricated in SCS;
- 2) Print heads can be fabricated in existing facilities (fabs) using standard VLSI processing equipment;
- 3) SCS has high mechanical strength and rigidity; and
- 4) SCS has a high thermal conductivity.

[0046] In this example, the nozzle is of cylindrical form, with the heater 103 forming an annulus. The nozzle tip 104 is formed from silicon dioxide layers 102 deposited during the fabrication of the CMOS drive circuitry. The nozzle tip is passivated with silicon nitride. The protruding nozzle tip controls the contact point of the pressurized ink 100 on the print head surface. The print head surface is also hydrophobized to prevent accidental spread of ink across the front of the print head.

[0047] Many other configurations of nozzles are possible, and nozzle embodiments of the invention may vary in shape, dimensions, and materials used. Monolithic nozzles etched from the substrate upon which the heater and drive electronics are formed have the advantage of not requiring an orifice plate. The elimination of the orifice plate has significant cost savings in manufacture and assembly. Recent methods for eliminating orifice plates include the use of 'vortex' actuators such as those described in Domoto et al US Pat. No. 4,580,158, 1986, assigned to Xerox, and Miller et al US Pat. No. 5,371,527, 1994 assigned to Hewlett-Packard. These, however are complex to actuate, and difficult to fabricate. The preferred method for elimination of orifice plates for print heads of the invention is incorporation of the orifice into the actuator substrate.

[0048] This type of nozzle may be used for print heads using various techniques for drop separation. Operation with Electrostatic Drop Separation

[0049] As a first example, operation using thermal reduction of surface tension and electrostatic drop separation is shown in figure 2.

[0050] Figure 2 shows the results of energy transport and fluid dynamic simulations performed using FIDAP, a commercial fluid dynamic simulation software package available from Fluid Dynamics Inc., of Illinois, USA. This simulation is of a thermal drop selection nozzle embodiment with a diameter of 8  $\mu\text{m}$ , at an ambient temperature of 30°C. The total energy applied to the heater is 276 nJ, applied as 69 pulses of 4 nJ each. The ink pressure is 10 kPa above ambient air pressure, and the ink viscosity at 30°C is 1.84 cPs. The ink is water based, and includes a sol of 0.1% palmitic acid to achieve an enhanced decrease in surface tension with increasing temperature. A cross section of the nozzle tip from the central axis of the nozzle to a radial distance of 40  $\mu\text{m}$  is shown. Heat flow in the various materials of the nozzle, including silicon, silicon nitride, amorphous silicon dioxide, crystalline silicon dioxide, and water based ink are simulated using the respective densities, heat capacities, and thermal conductivities of the materials. The time step of the simulation is 0.1  $\mu\text{s}$ .

**[0051]** Figure 2(a) shows a quiescent state, just before the heater is actuated. An equilibrium is created whereby no ink escapes the nozzle in the quiescent state by ensuring that the ink pressure plus external electrostatic field is insufficient to overcome the surface tension of the ink at the ambient temperature. In the quiescent state, the meniscus of the ink does not protrude significantly from the print head surface, so the electrostatic field is not significantly concentrated at the meniscus.

**[0052]** Figure 2(b) shows thermal contours at 5°C intervals 5 μs after the start of the heater energizing pulse. When the heater is energized, the ink in contact with the nozzle tip is rapidly heated. The reduction in surface tension causes the heated portion of the meniscus to rapidly expand relative to the cool ink meniscus. This drives a convective flow which rapidly transports this heat over part of the free surface of the ink at the nozzle tip. It is necessary for the heat to be distributed over the ink surface, and not just where the ink is in contact with the heater. This is because viscous drag against the solid heater prevents the ink directly in contact with the heater from moving.

**[0053]** Figure 2(c) shows thermal contours at 5°C intervals 10 μs after the start of the heater energizing pulse. The increase in temperature causes a decrease in surface tension, disturbing the equilibrium of forces. As the entire meniscus has been heated, the ink begins to flow.

**[0054]** Figure 2(d) shows thermal contours at 5°C intervals 20 μs after the start of the heater energizing pulse. The ink pressure has caused the ink to flow to a new meniscus position, which protrudes from the print head. The electrostatic field becomes concentrated by the protruding conductive ink drop.

**[0055]** Figure 2(e) shows thermal contours at 5°C intervals 30 μs after the start of the heater energizing pulse, which is also 6 μs after the end of the heater pulse, as the heater pulse duration is 24 μs. The nozzle tip has rapidly cooled due to conduction through the oxide layers, and conduction into the flowing ink. The nozzle tip is effectively 'water cooled' by the ink. Electrostatic attraction causes the ink drop to begin to accelerate towards the recording medium. Were the heater pulse significantly shorter (less than 16 μs in this case) the ink would not accelerate towards the print medium, but would instead return to the nozzle.

**[0056]** Figure 2(f) shows thermal contours at 5°C intervals 26 μs after the end of the heater pulse. The temperature at the nozzle tip is now less than 5°C above ambient temperature. This causes an increase in surface tension around the nozzle tip. When the rate at which the ink is drawn from the nozzle exceeds the viscously limited rate of ink flow through the nozzle, the ink in the region of the nozzle tip 'necks', and the selected drop separates from the body of ink. The selected drop then travels to the recording medium under the influence of the external electrostatic field. The meniscus of the ink at the nozzle tip then returns to its quiescent position, ready for the next heat pulse to select the next ink drop. One ink drop is selected, separated and forms a spot on the recording medium for each heat pulse. As the heat pulses are electrically controlled, drop on demand ink jet operation can be achieved.

**[0057]** Figure 3(a) shows successive meniscus positions during the drop selection cycle at 5 μs intervals, starting at the beginning of the heater energizing pulse.

**[0058]** Figure 3(b) is a graph of meniscus position versus time, showing the movement of the point at the centre of the meniscus. The heater pulse lasts 10 μs into the simulation.

**[0059]** Figure 3(c) shows the resultant curve of temperature with respect to time at various points in the nozzle. The vertical axis of the graph is temperature, in units of 100°C. The horizontal axis of the graph is time, in units of 10 μs. The temperature curve shown in figure 3(b) was calculated by FIDAP, using 0.1 μs time steps. The local ambient temperature is 30 degrees C. Temperature histories at three points are shown:

A - Nozzle tip: This shows the temperature history at the circle of contact between the passivation layer, the ink, and air.

B - Meniscus midpoint: This is at a circle on the ink meniscus midway between the nozzle tip and the centre of the meniscus.

C-Chip surface: This is at a point on the print head surface 20 μm from the centre of the nozzle. The temperature only rises a few degrees. This indicates that active circuitry can be located very close to the nozzles without experiencing performance or lifetime degradation due to elevated temperatures.

**[0060]** Figure 3(e) shows the power applied to the heater. Optimum operation requires a sharp rise in temperature at the start of the heater pulse, a maintenance of the temperature a little below the boiling point of the ink for the duration of the pulse, and a rapid fall in temperature at the end of the pulse. To achieve this, the average energy applied to the heater is varied over the duration of the pulse. In this case, the variation is achieved by pulse frequency modulation of 0.1 μs sub-pulses, each with an energy of 4 nJ. The peak power applied to the heater is 40 mW, and the average power over the duration of the heater pulse is 11.5 mW. The sub-pulse frequency in this case is 5 Mhz. This can readily be varied without significantly affecting the operation of the print head. A higher sub-pulse frequency allows finer control over the power applied to the heater. A sub-pulse frequency of 13.5 Mhz is suitable, as this frequency is also suitable for minimizing the effect of radio frequency interference (RFI).

Inks with a negative temperature coefficient of surface tension

[0061] The requirement for the surface tension of the ink to decrease with increasing temperature is not a major restriction, as most pure liquids and many mixtures have this property. Exact equations relating surface tension to temperature for arbitrary liquids are not available. However, the following empirical equation derived by Ramsay and Shields is satisfactory for many liquids:

$$\gamma_T = k \frac{(T_c - T - 6)}{\sqrt[3]{\left(\frac{Mx}{\rho}\right)^2}}$$

[0062] Where  $\gamma_T$  is the surface tension at temperature  $T$ ,  $k$  is a constant,  $T_c$  is the critical temperature of the liquid,  $M$  is the molar mass of the liquid,  $x$  is the degree of association of the liquid, and  $\rho$  is the density of the liquid. This equation indicates that the surface tension of most liquids falls to zero as the temperature reaches the critical temperature of the liquid. For most liquids, the critical temperature is substantially above the boiling point at atmospheric pressure, so to achieve an ink with a large change in surface tension with a small change in temperature around a practical ejection temperature, the admixture of surfactants is recommended.

[0063] The choice of surfactant is important. For example, water based ink for thermal ink jet printers often contains isopropyl alcohol (2-propanol) to reduce the surface tension and promote rapid drying. Isopropyl alcohol has a boiling point of 82.4°C, lower than that of water. As the temperature rises, the alcohol evaporates faster than the water, decreasing the alcohol concentration and causing an increase in surface tension. A surfactant such as 1-Hexanol (b.p. 158°C) can be used to reverse this effect, and achieve a surface tension which decreases slightly with temperature. However, a relatively large decrease in surface tension with temperature is desirable to maximize operating latitude. A surface tension decrease of 20 mN/m over a 30°C temperature range is preferred to achieve large operating margins, while as little as 10mN/m can be used to achieve operation of the print head according to the present invention.

Inks With Large  $-\Delta\gamma_T$ 

[0064] Several methods may be used to achieve a large negative change in surface tension with increasing temperature. Two such methods are:

1) The ink may contain a low concentration sol of a surfactant which is solid at ambient temperatures, but melts at a threshold temperature. Particle sizes less than 1,000 Å are desirable. Suitable surfactant melting points for a water based ink are between 50°C and 90°C, and preferably between 60°C and 80°C.

2) The ink may contain an oil/water microemulsion with a phase inversion temperature (PIT) which is above the maximum ambient temperature, but below the boiling point of the ink. For stability, the PIT of the microemulsion is preferably 20°C or more above the maximum non-operating temperature encountered by the ink. A PIT of approximately 80°C is suitable.

Ink- with Surfactant Sols

[0065] Inks can be prepared as a sol of small particles of a surfactant which melts in the desired operating temperature range. Examples of such surfactants include carboxylic acids with between 14 and 30 carbon atoms, such as:

Name	Formula	m.p.	Synonym
Tetradecanoic acid	CH <sub>3</sub> (CH <sub>2</sub> ) <sub>12</sub> COOH	58°C	Myristic acid
Hexadecanoic acid	CH <sub>3</sub> (CH <sub>2</sub> ) <sub>14</sub> COOH	63°C	Palmitic acid
Octadecanoic acid	CH <sub>3</sub> (CH <sub>2</sub> ) <sub>15</sub> COOH	71°C	Stearic acid
Eicosanoic acid	CH <sub>3</sub> (CH <sub>2</sub> ) <sub>16</sub> COOH	77°C	Arachidic acid
Docosanoic acid	CH <sub>3</sub> (CH <sub>2</sub> ) <sub>20</sub> COOH	80°C	Behenic acid

[0066] As the melting point of sols with a small particle size is usually slightly less than of the bulk material, it is pref-

erable to choose a carboxylic acid with a melting point slightly above the desired drop selection temperature. A good example is Arachidic acid.

[0067] These carboxylic acids are available in high purity and at low cost. The amount of surfactant required is very small, so the cost of adding them to the ink is insignificant. A mixture of carboxylic acids with slightly varying chain lengths can be used to spread the melting points over a range of temperatures. Such mixtures will typically cost less than the pure acid.

[0068] It is not necessary to restrict the choice of surfactant to simple unbranched carboxylic acids. Surfactants with branched chains or phenyl groups, or other hydrophobic moieties can be used. It is also not necessary to use a carboxylic acid. Many highly polar moieties are suitable for the hydrophilic end of the surfactant. It is desirable that the polar end be ionizable in water, so that the surface of the surfactant particles can be charged to aid dispersion and prevent flocculation. In the case of carboxylic acids, this can be achieved by adding an alkali such as sodium hydroxide or potassium hydroxide.

#### Preparation of Inks with Surfactant Sols

[0069] The surfactant sol can be prepared separately at high concentration, and added to the ink in the required concentration.

[0070] An example process for creating the surfactant sol is as follows:

- 1) Add the carboxylic acid to purified water in an oxygen free atmosphere.
- 2) Heat the mixture to above the melting point of the carboxylic acid. The water can be brought to a boil.
- 3) Ultrasonicate the mixture, until the typical size of the carboxylic acid droplets is between 100Å and 1,000Å.
- 4) Allow the mixture to cool.
- 5) Decant the larger particles from the top of the mixture.
- 6) Add an alkali such as NaOH to ionize the carboxylic acid molecules on the surface of the particles. A pH of approximately 8 is suitable. This step is not absolutely necessary, but helps stabilize the sol.
- 7) Centrifuge the sol. As the density of the carboxylic acid is lower than water, smaller particles will accumulate at the outside of the centrifuge, and larger particles in the centre.
- 8) Filter the sol using a microporous filter to eliminate any particles above 5000 Å.
- 9) Add the surfactant sol to the ink preparation. The sol is required only in very dilute concentration.

[0071] The ink preparation will also contain either dye(s) or pigment(s), bactericidal agents, agents to enhance the electrical conductivity of the ink if electrostatic drop separation is used, humectants, and other agents as required.

[0072] Anti-foaming agents will generally not be required, as there is no bubble formation during the drop ejection process.

#### Cationic surfactant sols

[0073] Inks made with anionic surfactant sols are generally unsuitable for use with cationic dyes or pigments. This is because the cationic dye or pigment may precipitate or flocculate with the anionic surfactant. To allow the use of cationic dyes and pigments, a cationic surfactant sol is required. The family of alkylamines is suitable for this purpose.

[0074] Various suitable alkylamines are shown in the following table:

Name	Formula	Synonym
Hexadecylamine	$\text{CH}_3(\text{CH}_2)_{14}\text{CH}_2\text{NH}_2$	Palmityl amine
Octadecylamine	$\text{CH}_3(\text{CH}_2)_{16}\text{CH}_2\text{NH}_2$	Stearyl amine
Eicosylamine	$\text{CH}_3(\text{CH}_2)_{18}\text{CH}_2\text{NH}_2$	Arachidyl amine
Docosylamine	$\text{CH}_3(\text{CH}_2)_{20}\text{CH}_2\text{NH}_2$	Behenyl amine

[0075] The method of preparation of cationic surfactant sols is essentially similar to that of anionic surfactant sols, except that an acid instead of an alkali is used to adjust the pH balance and increase the charge on the surfactant particles. A pH of 6 using HCl is suitable.

Microemulsion Based Inks

**[0076]** An alternative means of achieving a large reduction in surface tension as some temperature threshold is to base the ink on a microemulsion. A microemulsion is chosen with a phase inversion temperature (PIT) around the desired ejection threshold temperature. Below the PIT, the microemulsion is oil in water (O/W), and above the PIT the microemulsion is water in oil (W/O). At low temperatures, the surfactant forming the microemulsion prefers a high curvature surface around oil, and at temperatures significantly above the PIT, the surfactant prefers a high curvature surface around water. At temperatures close to the PIT, the microemulsion forms a continuous 'sponge' of topologically connected water and oil.

**[0077]** There are two mechanisms whereby this reduces the surface tension. Around the PIT, the surfactant prefers surfaces with very low curvature. As a result, surfactant molecules migrate to the ink/air interface, which has a curvature which is much less than the curvature of the oil emulsion. This lowers the surface tension of the water. Above the phase inversion temperature, the microemulsion changes from O/W to W/O, and therefore the ink/air interface changes from water/air to oil/air. The oil/air interface has a lower surface tension.

**[0078]** There is a wide range of possibilities for the preparation of microemulsion based inks.

**[0079]** For fast drop ejection, it is preferable to choose a low viscosity oil.

**[0080]** In many instances, water is a suitable polar solvent. However, in some cases different polar solvents may be required. In these cases, polar solvents with a high surface tension should be chosen, so that a large decrease in surface tension is achievable.

**[0081]** The surfactant can be chosen to result in a phase inversion temperature in the desired range. For example, surfactants of the group poly(oxyethylene)alkylphenyl ether (ethoxylated alkyl phenols, general formula:  $C_nH_{2n+1}C_4H_6(CH_2CH_2O)_mOH$ ) can be used. The hydrophilicity of the surfactant can be increased by increasing m, and the hydrophobicity can be increased by increasing n. Values of m of approximately 10, and n of approximately 8 are suitable.

**[0082]** Low cost commercial preparations are the result of a polymerization of various molar ratios of ethylene oxide and alkyl phenols, and the exact number of oxyethylene groups varies around the chosen mean. These commercial preparations are adequate, and highly pure surfactants with a specific number of oxyethylene groups are not required.

**[0083]** The formula for this surfactant is  $C_8H_{17}C_4H_6(CH_2CH_2O)_nOH$  (average  $n=10$ ).

**[0084]** Synonyms include Octoxynol-10, PEG-10 octyl phenyl ether and POE (10) octyl phenyl ether

**[0085]** The HLB is 13.6, the melting point is 7°C, and the cloud point is 65°C.

**[0086]** Commercial preparations of this surfactant are available under various brand names. Suppliers and brand names are listed in the following table:

Trade name	Supplier
Akyporox OP100	Chem-Y GmbH
Alkasurf OP-10	Rhone-Poulenc Surfactants and Specialties
Dehydrophen POP 10	Pulcra SA
Hyonic OP-10	Henkel Corp.
Iconol OP-10	BASF Corp.
Igepal O	Rhone-Poulenc France
Macol OP-10	PPG Industries
Malorphen 810	Huls AG
Nikkol OP-10	Nikko Chem. Co. Ltd.
Renex 750	ICI Americas Inc.
Rexol 45/10	Hart Chemical Ltd.
Synperonic OP10	ICI PLC
Teric X10	ICI Australia

**[0087]** These are available in large volumes at low cost (less than one dollar per pound in quantity), and so contribute

**EP 0 765 236 B1**

less than 10 cents per liter to prepared microemulsion ink with a 5% surfactant concentration.

**[0088]** Other suitable ethoxylated alkyl phenols include those listed in the following table:

5

Trivial name	Formula	HLB	Cloud point
Nonoxynol-9	$C_9H_{19}C_4H_6(CH_2CH_2O)_{\sim 9}OH$	13	54°C
Nonoxynol-10	$C_9H_{19}C_4H_6(CH_2CH_2O)_{\sim 10}OH$	13.2	62°C
Nonoxynol-11	$C_9H_{19}C_4H_6(CH_2CH_2O)_{\sim 11}OH$	13.8	72°C
Nonoxynol-12	$C_9H_{19}C_4H_6(CH_2CH_2O)_{\sim 12}OH$	14.5	81°C
Octoxynol-9	$C_8H_{17}C_4H_6(CH_2CH_2O)_{\sim 9}OH$	12.1	61°C
Octoxynol-10	$C_8H_{17}C_4H_6(CH_2CH_2O)_{\sim 10}OH$	13.6	65°C
Octoxynol-12	$C_8H_{17}C_4H_6(CH_2CH_2O)_{\sim 12}OH$	14.6	88°C
Dodoxynol-10	$C_{12}H_{25}C_4H_6(CH_2CH_2O)_{\sim 10}OH$	12.6	42°C
Dodoxynol-11	$C_{12}H_{25}C_4H_6(CH_2CH_2O)_{\sim 11}OH$	13.5	56°C
Dodoxynol-14	$C_{12}H_{25}C_4H_6(CH_2CH_2O)_{\sim 14}OH$	14.5	87°C

10

15

20

**[0089]** Microemulsion based inks have advantages other than surface tension control:

25

1) Microemulsions are thermodynamically stable, and will not separate. Therefore, the storage time can be very long. This is especially significant for office and portable printers, which may be used sporadically.

2) The microemulsion will form spontaneously with a particular drop size, and does not require extensive stirring, centrifuging, or filtering to ensure a particular range of emulsified oil drop sizes.

30

3) The amount of oil contained in the ink can be quite high, so dyes which are soluble in oil or soluble in water, or both, can be used. It is also possible to use a mixture of dyes, one soluble in water, and the other soluble in oil, to obtain specific colors.

4) Oil miscible pigments are prevented from flocculating, as they are trapped in the oil microdroplets.

5) The use of a microemulsion can reduce the mixing of different dye colors on the surface of the print medium.

6) The viscosity of microemulsions is very low.

35

7) The requirement for humectants can be reduced or eliminated.

Dyes and pigments in microemulsion based inks

40

**[0090]** Oil in water mixtures can have high oil contents - as high as 40% - and still form O/W microemulsions. This allows a high dye or pigment loading.

**[0091]** Mixtures of dyes and pigments can be used. An example of a microemulsion based ink mixture with both dye and pigment is as follows:

45

1) 70% water

2) 5% water soluble dye

3) 5% surfactant

4) 10% oil

5) 10% oil miscible pigment

50

**[0092]** The following table shows the nine basic combinations of colorants in the oil and water phases of the microemulsion that may be used.

55

Combination	Colorant in water phase	Colorant in oil phase
1	none	oil miscible pigment

(continued)

Combination	Colorant in water phase	Colorant in oil phase
2	none	oil soluble dye
3	water soluble dye	none
4	water soluble dye	oil miscible pigment
5	water soluble dye	oil soluble dye
6	pigment dispersed in water	none
7	pigment dispersed in water	oil miscible pigment
8	pigment dispersed in water	oil soluble dye
9	none	none

[0093] The ninth combination, with no colorants, is useful for printing transparent coatings, UV ink, and selective gloss highlights.

[0094] As many dyes are amphiphilic, large quantities of dyes can also be solubilized in the oil-water boundary layer as this layer has a very large surface area

[0095] It is also possible to have multiple dyes or pigments in each phase, and to have a mixture of dyes and pigments in each phase.

[0096] When using multiple dyes or pigments the absorption spectrum of the resultant ink will be the weighted average of the absorption spectra of the different colorants used. This presents two problems:

1) The absorption spectrum will tend to become broader, as the absorption peaks of both colorants are averaged. This has a tendency to 'muddy' the colors. To obtain brilliant color, careful choice of dyes and pigments based on their absorption spectra, not just their human-perceptible color, needs to be made.

2) The color of the ink may be different on different substrates. If a dye and a pigment are used in combination, the color of the dye will tend to have a smaller contribution to the printed ink color on more absorptive papers, as the dye will be absorbed into the paper, while the pigment will tend to 'sit on top' of the paper. This may be used as an advantage in some circumstances.

#### Surfactants with a Krafft point in the drop selection temperature range

[0097] For ionic surfactants there is a temperature (the Krafft point) below which the solubility is quite low, and the solution contains essentially no micelles. Above the Kraft temperature micelle formation becomes possible and there is a rapid increase in solubility of the surfactant. If the critical micelle concentration (CMC) exceeds the solubility of a surfactant at a particular temperature, then the minimum surface tension will be achieved at the point of maximum solubility, rather than at the CMC. Surfactants are usually much less effective below the Krafft point.

[0098] This factor can be used to achieve an increased reduction in surface tension with increasing temperature. At ambient temperatures, only a portion of the surfactant is in solution. When the nozzle heater is turned on, the temperature rises, and more of the surfactant goes into solution, decreasing the surface tension.

[0099] A surfactant should be chosen with a Krafft point which is near the top of the range of temperatures to which the ink is raised. This gives a maximum margin between the concentration of surfactant in solution at ambient temperatures, and the concentration of surfactant in solution at the drop selection temperature.

[0100] The concentration of surfactant should be approximately equal to the CMC at the Krafft point. In this manner, the surface tension is reduced to the maximum amount at elevated temperatures, and is reduced to a minimum amount at ambient temperatures.

[0101] The following table shows some commercially available surfactants with Krafft points in the desired range.

Formula	Krafft point
$C_{16}H_{33}SO_3^-Na^+$	57°C
$C_{18}H_{37}SO_3^-Na^+$	70°C

EP 0 765 236 B1

(continued)

Formula	Krafft point
$C_{16}H_{33}SO_4^-Na^+$	45°C
$Na^+O_4S(CH_2)_{16}SO_4^-Na^+$	44.9°C
$K^+O_4S(CH_2)_{16}SO_4^-K^+$	55°C
$C_{16}H_{33}CH(CH_3)C_4H_6SO_3^-Na^+$	60.8°C

Surfactants with a cloud point in the drop selection temperature range

[0102] Non-ionic surfactants using polyoxyethylene (POE) chains can be used to create an ink where the surface tension falls with increasing temperature. At low temperatures, the POE chain is hydrophilic, and maintains the surfactant in solution. As the temperature increases, the structured water around the POE section of the molecule is disrupted, and the POE section becomes hydrophobic. The surfactant is increasingly rejected by the water at higher temperatures, resulting in increasing concentration of surfactant at the air/ink interface, thereby lowering surface tension. The temperature at which the POE section of a nonionic surfactant becomes hydrophilic is related to the cloud point of that surfactant. POE chains by themselves are not particularly suitable, as the cloud point is generally above 100°C

[0103] Polyoxypropylene (POP) can be combined with POE in POE/POP block copolymers to lower the cloud point of POE chains without introducing a strong hydrophobicity at low temperatures.

[0104] Two main configurations of symmetrical POE/POP block copolymers are available. These are:

- 1) Surfactants with POE segments at the ends of the molecules, and a POP segment in the centre, such as the poloxamer class of surfactants (generically CAS 9003-11-6)
- 2) Surfactants with POP segments at the ends of the molecules, and a POE segment in the centre, such as the meroxapol class of surfactants (generically also CAS 9003-11-6)

[0105] Some commercially available varieties of poloxamer and meroxapol with a high surface tension at room temperature, combined with a cloud point above 40°C and below 100°C are shown in the following table:

Trivial name	BASF Trade name	Formula	Surface Tension (mN/m)	Cloud point
Merxapol 105	Pluronic 10R5	$HO(CHCH_3CH_2O)_{\sim 7}-(CH_2CH_2O)_{\sim 22}-(CHCH_3CH_2O)_{\sim 7}OH$	50.9	69°C
Merxapol 108	Pluronic 10R8	$HO(CHCH_3CH_2O)_{\sim 7}-(CH_2CH_2O)_{\sim 91}-(CHCH_3CH_2O)_{\sim 7}OH$	54.1	99°C
Merxapol 178	Pluronic 17R8	$HO(CHCH_3CH_2O)_{\sim 12}-(CH_2CH_2O)_{\sim 136}-(CHCH_3CH_2O)_{\sim 12}OH$	47.3	81°C
Merxapol 258	Pluronic 25R8	$HO(CHCH_3CH_2O)_{\sim 18}-(CH_2CH_2O)_{\sim 163}-(CHCH_3CH_2O)_{\sim 18}OH$	46.1	80°C
Poloxamer 105	Pluronic L35	$HO(CH_2CH_2O)_{\sim 11}-(CHCH_3CH_2O)_{\sim 16}-(CH_2CH_2O)_{\sim 11}OH$	48.8	77°C
Poloxamer 124	Pluronic L44	$HO(CH_2CH_2O)_{\sim 11}-(CHCH_3CH_3O)_{\sim 11}-(CH_2CH_2O)_{\sim 11}OH$	45.3	65°C

[0106] Other varieties of poloxamer and merxapol can readily be synthesis using well known techniques. Desirable characteristics are a room temperature surface tension which is as high as possible, and a cloud point between 40°C ad 100°C, and preferably between 60°C and 80°C.

[0107] Merxapol  $[\text{HO}(\text{CHCH}_3\text{CH}_2\text{O})_x(\text{CH}_2\text{CH}_2\text{O})_y(\text{CHCH}_3\text{CH}_2\text{O})_z\text{OH}]$  varieties where the average x and z are approximately 4, and the average y is approximately 15 may be suitable.

[0108] If salts are used to increase the electrical conductivity of the ink, then the effect of this salt on the cloud point of the surfactant should be considered.

[0109] The cloud point of POE surfactants is increased by ions that disrupt water structure (such as  $\text{I}^-$ ), as this makes more water molecules available to form hydrogen bonds with the POE oxygen lone pairs. The cloud point of POE surfactants is decreased by ions that form water structure (such as  $\text{Cl}^-$ ,  $\text{OH}^-$ ), as fewer water molecules are available to form hydrogen bonds. Bromide ions have relatively little effect. The ink composition can be 'tuned' for a desired temperature range by altering the lengths of POE and POP chains in a block copolymer surfactant, and by changing the choice of salts (e.g  $\text{Cl}^-$  to  $\text{Br}^-$  to  $\text{I}^-$ ) that are added to increase electrical conductivity. NaCl is likely to be the best choice of salts to increase ink conductivity, due to low cost and non-toxicity. NaCl slightly lowers the cloud point of nonionic surfactants.

#### Hot Melt Inks

[0110] The ink need not be in a liquid state at room temperature. Solid 'hot melt' inks can be used by heating the printing head and ink reservoir above the melting point of the ink. The hot melt ink must be formulated so that the surface tension of the molten ink decreases with temperature. A decrease of approximately 2 mN/m will be typical of many such preparations using waxes and other substances. However, a reduction in surface tension of approximately 20 mN/m is desirable in order to achieve good operating margins when relying oil a reduction in surface tension rather than a reduction in viscosity.

[0111] The temperature difference between quiescent temperature and drop selection temperature may be greater for a hot melt ink than for a water based ink, as water based inks are constrained by the boiling point of the water.

[0112] The ink must be liquid at the quiescent temperature. The quiescent temperature should be higher than the highest ambient temperature likely to be encountered by the printed page. The quiescent temperature should also be as low as practical, to reduce the power needed to heat the print head, and to provide a maximum margin between the quiescent and the drop ejection temperatures. A quiescent temperature between 60°C and 90°C is generally suitable, though other temperatures may be used. A drop ejection temperature of between 160°C and 200°C is generally suitable.

[0113] There are several methods of achieving an enhanced reduction in surface tension with increasing temperature.

1) A dispersion of microfine particles of a surfactant with a melting point substantially above the quiescent temperature, but substantially below the drop ejection temperature, can be added to the hot melt ink while in the liquid phase.

2) A polar/non-polar microemulsion with a PIT which is preferably at least 20°C above the melting points of both the polar and non-polar compounds.

[0114] To achieve a large reduction in surface tension with temperature, it is desirable that the hot melt ink carrier have a relatively large surface tension (above 30 mN/m) when at the quiescent temperature. This generally excludes canes such as waxes. Suitable materials will generally have a strong intermolecular attraction, which may be achieved by multiple hydrogen bonds, for example, polyols, such as Hexanetetrol, which has a melting point of 88°C.

#### Surface tension reduction of various solutions

[0115] Figure 3(d) shows the measured effect of temperature on the surface tension of various aqueous preparations containing the following additives:

- 1) 0.1% sol of Stearic Acid
- 2) 0.1% sol of Palmitic acid
- 3) 0.1% solution of Pluronic 10R5 (trade mark of BASF)
- 4) 0.1% solution of Pluronic L35 (trade mark of BASF)
- 5) 0.1% solution of Pluronic L44 (trade mark of BASF)

[0116] Inks suitable for printing systems of the present invention are described in the following Australian patent specifications, the disclosure of which are hereby incorporated by reference:

'Ink composition based on a microemulsion' (Filing no.: PN5223, filed on 6 September 1995);

'Ink composition containing surfactant sol' (Filing no.: PN5224, filed on 6 September 1995);

'Ink composition for DOD printers with Krafft point near the drop selection temperature sol' (Filing no.: PN6240, filed on 30 October 1995); and

5 'Dye and pigment in a microemulsion based ink' (Filing no.: PN6241, filed on 30 October 1995).

#### Operation Using Reduction of Viscosity

10 **[0117]** As a second example, operation of an embodiment using thermal reduction of viscosity and proximity drop separation, in combination with hot melt ink, is as follows. Prior to operation of the printer, solid ink is melted in the reservoir 64. The reservoir, ink passage to the print head, ink channels 75, and print head 50 are maintained at a temperature at which the ink 100 is liquid, but exhibits a relatively high viscosity (for example, approximately 100 cP). The ink 100 is retained in the nozzle by the surface tension of the ink. The ink 100 is formulated so that the viscosity of the ink reduces with increasing temperature. The ink pressure oscillates at a frequency which is an integral multiple of the drop ejection  
15 frequency from the nozzle. The ink pressure oscillation causes oscillations of the ink meniscus at the nozzle tips, but this oscillation is small due to the high ink viscosity. At the normal operating temperature, these oscillations are of insufficient amplitude to result in drop separation. When the heater 103 is energized, the ink forming the selected drop is heated, causing a reduction in viscosity to a value which is preferably less than 5 cP. The reduced viscosity results in the ink meniscus moving further during the high pressure part of the ink pressure cycle. The recording medium 51 is  
20 arranged sufficiently close to the print head 50 so that the selected drops contact the recording medium 51, but sufficiently far away that the unselected drops do not contact the recording medium 51. Upon contact with the recording medium 51, part of the selected drop freezes, and attaches to the recording medium. As the ink pressure falls, ink begins to move back into the nozzle. The body of ink separates from the ink which is frozen onto the recording medium. The meniscus of the ink 100 at the nozzle tip then returns to low amplitude oscillation. The viscosity of the ink increases  
25 to its quiescent level as remaining heat is dissipated to the bulk ink and print head. One ink drop is selected, separated and forms a spot on the recording medium 51 for each heat pulse. As the heat pulses are electrically controlled, drop on demand ink jet operation can be achieved.

#### Image Processing for Print Heads

30 **[0118]** An objective of printing systems according to the invention is to attain a print quality which is equal to that which people are accustomed to in quality color publications printed using offset printing. This can be achieved using a print resolution of approximately 1,600 dpi. However, 1,600 dpi printing is difficult and expensive to achieve. Similar results can be achieved using 800 dpi printing, with 2 bits per pixel for cyan and magenta, and one bit per pixel for yellow and  
35 black. This color model is herein called CC'MM'YK. Where high quality monochrome image printing is also required, two bits per pixel can also be used for black. This color model is herein called CC'MM'YKK'.

#### Applications Using Print Heads According to this Invention

40 **[0119]** Printing apparatus and methods of this invention are suitable for a wide range of applications, including (but not limited to) the following: color and monochrome office printing, short run digital printing, high speed digital printing, process color printing, spot color printing, offset press supplemental printing, low cost printers using scanning print heads, high speed printers using pagewidth print heads, portable color and monochrome printers, color and mono-  
45 chrome copiers, color and monochrome facsimile machines, combined printer, facsimile and copying machines, label printing, large format plotters, photographic duplication, printers for digital photographic processing, portable printers incorporated into digital 'instant' cameras, video printing, printing of PhotoCD images, portable printers for 'Personal Digital Assistants', wallpaper printing, indoor sign printing, billboard printing, and fabric printing.

#### Compensation of Print Heads for Environmental Conditions

50 **[0120]** It is desirable that drop on demand printing systems have consistent and predictable ink drop size and position. Unwanted variation in ink drop size and position causes variations in the optical density of the resultant print, reducing the perceived print quality. These variations should be kept to a small proportion of the nominal ink drop volume and pixel spacing respectively. Many environmental variables can be compensated to reduce their effect to insignificant lev-  
55 els. Active compensation of some factors can be achieved by varying the power applied to the nozzle heaters.

**[0121]** An optimum temperature profile for one print head embodiment involves an instantaneous raising of the active region of the nozzle tip to the ejection temperature, maintenance of this region at the ejection temperature for the duration of the pulse, and instantaneous cooling of the region to the ambient temperature.

[0122] This optimum is not achievable due to the stored heat capacities and thermal conductivities of the various materials used in the fabrication of the nozzles in accordance with the invention. However, improved performance can be achieved by shaping the power pulse using curves which can be derived by iterative refinement of finite element simulation of the print head. The power applied to the heater can be varied in time by various techniques, including, but not limited to:

- 1) Varying the voltage applied to the heater
- 2) Modulating the width of a series of short pulses (PWM)
- 3) Modulating the frequency of a series of short pulses (PFM)

[0123] To obtain accurate results, a transient fluid dynamic simulation with free surface modeling is required, as convection in the ink, and ink flow, significantly affect on the temperature achieved with a specific power curve.

[0124] By the incorporation of appropriate digital circuitry on the print head substrate, it is practical to individually control the power applied to each nozzle. One way to achieve this is by 'broadcasting' a variety of different digital pulse trains across the print head chip, and selecting the appropriate pulse train for each nozzle using multiplexing circuits.

[0125] An example of the environmental factors which may be compensated for is listed in the table "Compensation for environmental factors". This table identifies which environmental factors are best compensated globally (for the entire print head), per chip (for each chip in a composite multi-chip print head), and per nozzle.

<i>Compensation for environmental factors</i>			
<b>Factor compensated</b>	<b>Scope</b>	<b>Sensing or user control method</b>	<b>Compensation mechanism</b>
Ambient Temperature	Global	Temperature sensor mounted on print head or	Power supply voltage global PFM patterns
Power supply voltage fluctuation with number of active nozzles	Global	Predictive active nozzle count based on print data	Power supply voltage or global PFM patterns
Local heat build-up with successive nozzle actuation	Per nozzle	Predictive active nozzle count based on print data	Selection of appropriate PFM pattern for each printed drop
Drop size control for multiple bits per pixel	Per nozzle	Image data	Selection of appropriate PFM pattern for each printed drop
Nozzle geometry variations between wafers	Per chip	Factory measurement, datafile supplied with print head	Global PFM patterns per print head chip
Heater resistivity variations between wafers	per chip	Factory measurement, datafile supplied with print head	Global PFM patterns per print head chip
User image intensity adjustment	Global	User selection	Power supply voltage, electrostatic acceleration voltage, or ink pressure
Ink surface tension reduction method and threshold temperature	Global	Ink cartridge sensor or user selection	Global PFM patterns
Ink viscosity	Global	Ink cartridge sensor or user selection	Global PFM patterns and/or clock rate
Ink dye or pigment concentration	Global	Ink cartridge sensor or user selection	Global PFM patterns
Ink response time	Global	Ink cartridge sensor or user selection	Global PFM patterns

[0126] Most applications will not require compensation for all of these variables. Some variables have a minor effect, and compensation is only necessary where very high image quality is required.

Print head drive circuits

**[0127]** Figure 4 is a block schematic diagram showing electronic operation of an example head driver circuit in accordance with this invention. This control circuit uses analog modulation of the power supply voltage applied to the print head to achieve heater power modulation, and does not have individual control of the power applied to each nozzle. Figure 4 shows a block diagram for a system using an 800 dpi pagewidth print head which prints process color using the CC'MM'YK color model. The print head 50 has a total of 79,488 nozzles, with 39,744 main nozzles and 39,744 redundant nozzles. The main and redundant nozzles are divided into six colors, and each color is divided into 8 drive phases. Each drive phase has a shift register which converts the serial data from a head control ASIC 400 into parallel data for enabling heater drive circuits. There is a total of 96 shift registers, each providing data for 828 nozzles. Each shift register is composed of 828 shift register stages 217, the outputs of which are logically anded with phase enable signal by a nand gate 215. The output of the nand gate 215 drives an inverting buffer 216, which in turn controls the drive transistor 201. The drive transistor 201 actuates the electrothermal heater 200, which may be a heater 103 as shown in figure 1(b). To maintain the shifted data valid during the enable pulse, the clock to the shift register is stopped the enable pulse is active by a clock stopper 218, which is shown as a single gate for clarity, but is preferably any of a range of well known glitch free clock control circuits. Stopping the clock of the shift register removes the requirement for a parallel data latch in the print head, but adds some complexity to the control circuits in the Head Control ASIC 400. Data is routed to either the main nozzles or the redundant nozzles by the data router 219 depending on the state of the appropriate signal of the fault status bus.

**[0128]** The print head shown in figure 4 is simplified, and does not show various means of improving manufacturing yield, such as block fault tolerance. Drive circuits for different configurations of print head can readily be derived from the apparatus disclosed herein.

**[0129]** Digital information representing patterns of dots to be printed on the recording medium is stored in the Page or Band memory 1513, which may be the same as the Image memory 72 in figure 1(a). Data in 32 bit words representing dots of one color is read from the Page or Band memory 1513 using addresses selected by the address mux 417 and control signals generated by the Memory Interface 418. These addresses are generated by Address generators 411, which forms part of the 'Per color circuits' 410, for which there is one for each of the six color components. The addresses are generated based on the positions of the nozzles in relation to the print medium. As the relative position of the nozzles may be different for different print heads, the Address generators 411 are preferably made programmable. The Address generators 411 normally generate the address corresponding to the position of the main nozzles. However, when faulty nozzles are present, locations of blocks of nozzles containing faults can be marked in the Fault Map RAM 412. The Fault Map RAM 412 is read as the page is printed. If the memory indicates a fault in the block of nozzles, the address is altered so that the Address generators 411 generate the address corresponding to the position of the redundant nozzles. Data read from the Page or Band memory 1513 is latched by the latch 413 and converted to four sequential bytes by the multiplexer 414. Timing of these bytes is adjusted to match that of data representing other colors by the FIFO 415. This data is then buffered by the buffer 430 to form the 48 bit main data bus to the print head 50. The data is buffered as the print head may be located a relatively long distance from the head control ASIC. Data from the Fault Map RAM 412 also forms the input to the FIFO 416. The timing of this data is matched to the data output of the FIFO 415, and buffered by the buffer 431 to form the fault status bus.

**[0130]** The programmable power supply 320 provides power for the head 50. The voltage of the power supply 320 is controlled by the DAC 313, which is part of a RAM and DAC combination (RAMDAC) 316. The RAMDAC 316 contains a dual port RAM 317. The contents of the dual port RAM 317 are programmed by the Microcontroller 315. Temperature is compensated by changing the contents of the dual Port RAM 317. These values are calculated by the microcontroller 315 based on temperature sensed by a thermal sensor 300. The thermal sensor 300 signal connects to the Analog to Digital Converter (ADC) 311. The ADC 311 is preferably incorporated in the Microcontroller 315.

**[0131]** The Head Control ASIC 400 contains control circuits for thermal lag compensation and print density. Thermal lag compensation requires that the power supply voltage to the head 50 is a rapidly time-varying voltage which is synchronized with the enable pulse for the heater. This is achieved by programming the programmable power supply 320 to produce this voltage. An analog time varying programming voltage is produced by the DAC 313 based upon data read from the dual port RAM 317. The data is read according to an address produced by the counter 403. The counter 403 produces one complete cycle of addresses during the period of one enable pulse. This synchronization is ensured, as the counter 403 is clocked by the system clock 408, and the top count of the counter 403 is used to clock the enable counter 404. The count from the enable counter 404 is then decoded by the decoder 405 and buffered by the buffer 432 to produce the enable pulses for the head 50. The counter 403 may include a prescaler if the number of states in the count is less than the number of clock periods in one enable pulse. Sixteen voltage states are adequate to accurately compensate for the heater thermal lag. These sixteen states can be specified by using a four bit connection between the counter 403 and the dual port RAM 317. However, these sixteen states may not be linearly spaced in time. To allow non-linear timing of these states the counter 403 may also include a ROM or other device which causes the counter 403

to count in a non-linear fashion. Alternatively, fewer than sixteen states may be used.

[0132] For print density compensation, the printing density is detected by counting the number of pixels to which a drop is to be printed ('on' pixels) in each enable period. The 'on' pixels are counted by the On pixel counters 402. There is one On pixel counter 402 for each of the eight enable phases. The number of enable phases in a print head in accordance with the invention depend upon the specific design. Four, eight, and sixteen are convenient numbers, though there is no requirement that the number of enable phases is a power of two. The On Pixel Counters 402 can be composed of combinatorial logic pixel counters 420 which determine how many bits in a nibble of data are on. This number is then accumulated by the adder 421 and accumulator 422. A latch 423 holds the accumulated value valid for the duration of the enable pulse. The multiplexer 401 selects the output of the latch 423 which corresponds to the current enable phase, as determined by the enable counter 404. The output of the multiplexer 401 forms part of the address of the dual port RAM 317. An exact count of the number of 'on' pixels is not necessary, and the most significant four bits of this count are adequate.

[0133] Combining the four bits of thermal lag compensation address and the four bits of print density compensation address means that the dual port RAM 317 has an 8 bit address. This means that the dual port RAM 317 contains 256 numbers, which are in a two dimensional array. These two dimension are time (for thermal lag compensation) and print density. A third dimension - temperature - can be included. As the ambient temperature of the head varies only slowly, the microcontroller 315 has sufficient time to calculate a matrix of 256 numbers compensating for thermal lag and print density at the current temperature. Periodically (for example, a few times a second), the microcontroller senses the current head temperature and calculates this matrix.

[0134] The clock to the print head 50 is generated from the system clock 408 by the Head clock generator 407, and buffered by the buffer 406. To facilitate testing of the Head control ASIC, JTAG test circuits 499 may be included.

Comparison with thermal ink jet technology

[0135] The table "Comparison between Thermal ink jet and Present Invention" compares the aspects of printing in accordance with the present invention with thermal ink jet printing technology.

[0136] A direct comparison is made between the present invention and thermal ink jet technology because both are drop on demand systems which operate using thermal actuators and liquid ink. Although they may appear similar, the two technologies operate on different principles.

[0137] Thermal ink jet printers use the following fundamental operating principle. A thermal impulse caused by electrical resistance heating results in the explosive formation of a bubble in liquid ink. Rapid and consistent bubble formation can be achieved by superheating the ink, so that sufficient heat is transferred to the ink before bubble nucleation is complete. For water based ink, ink temperatures of approximately 280°C to 400°C are required. The bubble formation causes a pressure wave which forces a drop of ink from the aperture with high velocity. The bubble then collapses, drawing ink from the ink reservoir to refill the nozzle. Thermal ink jet printing has been highly successful commercially due to the high nozzle packing density and the use of well established integrated circuit manufacturing techniques. However, thermal ink jet printing technology faces significant technical problems including multi-part precision fabrication, device yield, image resolution, 'pepper' noise, printing speed, drive transistor power, waste power dissipation, satellite drop formation, thermal stress, differential thermal expansion, kogation, cavitation, rectified diffusion, and difficulties in ink formulation.

[0138] Printing in accordance with the present invention has many of the advantages of thermal ink jet printing, and completely or substantially eliminates many of the inherent problems of thermal ink jet technology.

*Comparison between Thermal ink jet and Present Invention*

	<b>Thermal Ink Jet</b>	<b>Present Invention</b>
<b>Drop selection mechanism</b>	Drop ejected by pressure wave caused by thermally induced bubble	Choice of surface tension or viscosity reduction mechanisms
<b>Drop separation mechanism</b>	Same as drop selection mechanism	Choice of proximity, electrostatic, magnetic, and other methods
<b>Basic ink carrier</b>	Water	Water, microemulsion, alcohol, glycol, or hot melt
<b>Head construction</b>	Precision assembly of nozzle plate, ink channel, and substrate	Monolithic

EP 0 765 236 B1

(continued)

<i>Comparison between Thermal ink jet and Present Invention</i>			
	<b>Thermal Ink Jet</b>	<b>Present Invention</b>	
5	<b>Per copy printing cost</b>	Very high due to limited print head life and expensive inks	Can be low due to permanent print heads and wide range of possible inks
	<b>Satellite drop formation</b>	Significant problem which degrades image quality	No satellite drop formation
10	<b>Operating ink temperature</b>	280°C to 400°C (high temperature limits dye use and ink formulation)	Approx. 70°C (depends upon ink formulation)
	<b>Peak heater temperature</b>	400°C to 1,000°C (high temperature reduces device life)	Approx. 130°C
15	<b>Cavitation (heater erosion by bubble collapse)</b>	Serious problem limiting head life	None (no bubbles are formed)
	<b>Kogation (coating of heater by ink ash)</b>	Serious problem limiting head life and ink formulation	None (water based ink temperature does not exceed 100°C)
20	<b>Rectified diffusion (formation of ink bubbles due to pressure cycles)</b>	Serious problem limiting ink formulation	Does not occur as the ink pressure does not go negative
	<b>Resonance</b>	Serious problem limiting nozzle design and repetition rate	Very small effect as pressure waves are small
25	<b>Practical resolution</b>	Approx. 800 dpi max.	Approx. 1,600 dpi max.
	<b>Self-cooling operation</b>	No (high energy required)	Yes: printed ink carries away drop selection energy
30	<b>Drop ejection velocity</b>	High (approx. 10 m/sec)	Low (approx. 1 m/sec)
	<b>Crosstalk</b>	Serious problem requiring careful acoustic design, which limits nozzle refill rate.	Low velocities and pressures associated with drop ejection make crosstalk very small.
35	<b>Operating thermal stress</b>	Serious problem limiting print-head life.	Low: maximum temperature increase approx. 90°C at centre of heater.
	<b>Manufacturing thermal stress</b>	Serious problem limiting print-head size.	Same as standard CMOS manufacturing process.
40	<b>Drop selection energy</b>	Approx. 20 μJ	Approx. 270 nJ
	<b>Heater pulse period</b>	Approx. 2-3 μs	Approx. 15-30 μs
	<b>Average heater pulse power</b>	Approx. 8 Watts per heater.	Approx. 12 mW per heater. This is more than 500 times less than Thermal Ink-Jet.
45	<b>Heater pulse voltage</b>	Typically approx. 40V.	Approx. 5 to 10V.
	<b>Heater peak pulse current</b>	Typically approx. 200 mA per heater. This requires bipolar or very large MOS drive transistors.	Approx. 4 mA per heater. This allows the use of small MOS drive transistors.
50	<b>Fault tolerance</b>	Not implemented. Not practical for edge shooter type.	Simple implementation results in better yield and reliability
	<b>Constraints on ink composition</b>	Many constraints including kogation, nucleation, etc.	Temperature coefficient of surface tension or viscosity must be negative.
55	<b>Ink pressure</b>	Atmospheric pressure or less	Approx. 1.1 atm

(continued)

<i>Comparison between Thermal ink jet and Present Invention</i>			
	<b>Thermal Ink Jet</b>	<b>Present Invention</b>	
5	<b>Integrated drive circuitry</b>	Bipolar circuitry usually required due to high drive current	CMOS, nMOS, or bipolar
	<b>Differential thermal expansion</b>	Significant problem for large print heads	Monolithic construction reduces problem
10	<b>Pagewidth print heads</b>	Major problems with yield, cost, precision construction, head life, and power dissipation	High yield, low cost and long life due to fault tolerance. Self cooling due to low power dissipation.

15 Yield and Fault Tolerance

[0139] In most cases, monolithic integrated circuits cannot be repaired if they are not completely functional when manufactured. The percentage of operational devices which are produced from a wafer run is known as the yield. Yield has a direct influence on manufacturing cost. A device with a yield of 5% is effectively ten times more expensive to manufacture than an identical device with a yield of 50%.

[0140] There are three major yield measurements:

- 1) Fab yield
- 2) Wafer sort yield
- 25 3) Final test yield

[0141] For large die, it is typically the wafer sort yield which is the most serious limitation on total yield. Full pagewidth color heads in accordance with this invention are very large in comparison with typical VLSI circuits. Good wafer sort yield is critical to the cost-effective manufacture of such heads.

30 [0142] Figure 5 is a graph of wafer sort yield versus defect density for a monolithic full width color A4 head embodiment of the invention. The head is 215 mm long by 5 mm wide. The non fault tolerant yield 198 is calculated according to Murphy's method, which is a widely used yield prediction method. With a defect density of one defect per square cm, Murphy's method predicts a yield less than 1%. This means that more than 99% of heads fabricated would have to be discarded. This low yield is highly undesirable, as the print head manufacturing cost becomes unacceptably high.

35 [0143] Murphy's method approximates the effect of an uneven distribution of defects. Figure 5 also includes a graph of non fault tolerant yield 197 which explicitly models the clustering of defects by introducing a defect clustering factor. The defect clustering factor is not a controllable parameter in manufacturing, but is a characteristic of the manufacturing process. The defect clustering factor for manufacturing processes can be expected to be approximately 2, in which case yield projections closely match Murphy's method.

40 [0144] A solution to the problem of low yield is to incorporate fault tolerance by including redundant functional units on the chip which are used to replace faulty functional units.

[0145] In memory chips and most Wafer Scale Integration (WSI) devices, the physical location of redundant sub-units on the chip is not important. However, in printing heads the redundant sub-unit may contain one or more printing actuators. These must have a fixed spatial relationship to the page being printed. To be able to print a dot in the same position as a faulty actuator, redundant actuators must not be displaced in the non-scan direction. However, faulty actuators can be replaced with redundant actuators which are displaced in the scan direction. To ensure that the redundant actuator prints the dot in the same position as the faulty actuator, the data timing to the redundant actuator can be altered to compensate for the displacement in the scan direction.

45 [0146] To allow replacement of all nozzles, there must be a complete set of spare nozzles, which results in 100% redundancy. The requirement for 100% redundancy would normally more than double the chip area, dramatically reducing the primary yield before substituting redundant units, and thus eliminating most of the advantages of fault tolerance.

50 [0147] However, with print head embodiments according to this invention, the minimum physical dimensions of the head chip are determined by the width of the page being printed, the fragility of the head chip, and manufacturing constraints on fabrication of ink channels which supply ink to the back surface of the chip. The minimum practical size for a full width, full color head for printing A4 size paper is approximately 215 mm x 5 mm. This size allows the inclusion of 100% redundancy without significantly increasing chip area, when using 1.5 μm CMOS fabrication technology. Therefore, a high level of fault tolerance can be included without significantly decreasing primary yield.

**[0148]** When fault tolerance is included in a device, standard yield equations cannot be used. Instead, the mechanisms and degree of fault tolerance must be specifically analyzed and included in the yield equation. Figure 5 shows the fault tolerant sort yield 199 for a full width color A4 head which includes various forms of fault tolerance, the modeling of which has been included in the yield equation. This graph shows projected yield as a function of both defect density and defect clustering. The yield projection shown in figure 5 indicates that thoroughly implemented fault tolerance can increase wafer sort yield from under 1% to more than 90% under identical manufacturing conditions. This can reduce the manufacturing cost by a factor of 100.

**[0149]** Fault tolerance is highly recommended to improve yield and reliability of print heads containing thousands of printing nozzles, and thereby make pagewidth printing heads practical. However, fault tolerance is not to be taken as an essential part of the present invention.

#### Printing System Embodiments

**[0150]** A schematic diagram of a digital electronic printing system using a print head of this invention is shown in Figure 6(a). This shows a monolithic printing head 50 printing an image 60 composed of a multitude of ink drops onto a recording medium 51. This medium will typically be paper, but can also be overhead transparency film, cloth, or many other substantially flat surfaces which will accept ink drops. The image to be printed is provided by an image source 52, which may be any image type which can be converted into a two dimensional array of pixels. Typical image sources are image scanners, digitally stored images, images encoded in a page description language (PDL) such as Adobe Postscript, Adobe Postscript level 2, or Hewlett-Packard PCL 5, page images generated by a procedure-call based rasterizer, such as Apple QuickDraw, Apple Quickdraw GX, or Microsoft GDI, or text in an electronic form such as ASCII. This image data is then converted by an image processing system 53 into a two dimensional array of pixels suitable for the particular printing system. This may be color or monochrome, and the data will typically have between 1 and 32 bits per pixel, depending upon the image source and the specification of the printing system. The image processing system may be a raster image processor (RIP) if the source image is a page description, or may be a two dimensional image processing system if the source image is from a scanner.

**[0151]** If continuous tone images are required, then a halftoning system 54 is necessary. Suitable types of halftoning are based on *dispersed dot ordered dither or error diffusion*. Variations of these, commonly known as *stochastic screening or frequency modulation screening* are suitable. The halftoning system commonly used for offset printing - *clustered dot ordered dither* - is not recommended, as effective image resolution is unnecessarily wasted using this technique. The output of the halftoning system is a binary monochrome or color image at the resolution of the printing system according to the present invention.

**[0152]** The binary image is processed by a data phasing circuit 55 (which may be incorporated in a Head Control ASIC 400 as shown in figure 4) which provides the pixel data in the correct sequence to the data shift registers 56. Data sequencing is required to compensate for the nozzle arrangement and the movement of the paper. When the data has been loaded into the shift registers 56, it is presented in parallel to the heater driver circuits 57. At the correct time, the driver circuits 57 will electronically connect the corresponding heaters 58 with the voltage pulse generated by the pulse shaper circuit 61 and the voltage regulator 62. The heaters 58 heat the tip of the nozzles 59, affecting the physical characteristics of the ink. Ink drops 60 escape from the nozzles in a pattern which corresponds to the digital impulses which have been applied to the heater driver circuits. The pressure of the ink in the ink reservoir 64 is regulated by the pressure regulator 63. Selected drops of ink drops 60 are separated from the body of ink by the chosen drop separation means, and contact the recording medium 51. During printing, the recording medium 51 is continually moved relative to the print head 50 by the paper transport system 65. If the print head 50 is the full width of the print region of the recording medium 51, it is only necessary to move the recording medium 51 in one direction, and the print head 50 can remain fixed. If a smaller print head 50 is used, it is necessary to implement a raster scan system. This is typically achieved by scanning the print head 50 along the short dimension of the recording medium 51, while moving the recording medium 51 along its long dimension.

**[0153]** The binary image is processed by a data phasing circuit 55 (which may be incorporated in a Head Control ASIC 400 as shown in figure 4) which provides the pixel data in the correct sequence to the data shift registers 56. Data sequencing is required to compensate for the nozzle arrangement and the movement of the paper. When the data has been loaded into the shift registers 56, it is presented in parallel to the heater driver circuits 57. At the correct time, the driver circuits 57 will electronically connect the corresponding heaters 58 with the voltage pulse generated by the pulse shaper circuit 61 and the voltage regulator 62. The heaters 58 heat the tip of the nozzles 59, affecting the physical characteristics of the ink. Ink: drops 60 escape from the nozzles in a pattern which corresponds to the digital impulses which have been applied to the heater driver circuits. The pressure of the ink in the ink reservoir 64 is regulated by the pressure regulator 63. Selected drops of ink drops 60 are separated from the body of ink by the chosen drop separation means, and contact the recording medium 51. During printing, the recording medium 51 is continually moved relative to the print head 50 by the paper transport system 65. If the print head 50 is the full width of the print region of the

recording medium 51, it is only necessary to move the recording medium 51 in one direction, and the print head 50 can remain fixed. If a smaller print head 50 is used, it is necessary to implement a raster scan system. This is typically achieved by scanning the print head 50 along the short dimension of the recording medium 51, while moving the recording medium 51 along its long dimension.

5

Computer simulations of nozzle dynamics

[0154] Computer simulation is extremely useful in determining the characteristics of phenomena which are difficult to observe directly, nozzle operation is difficult to observe experimentally for several reasons, including:

10

- 1) Useful nozzles are microscopic, with important phenomena occurring at dimensions less than 1µm.
- 2) The time scale of a drop ejection is a few microseconds, requiring very high speed observations.
- 3) Important phenomena occur inside opaque solid materials, making direct observation impossible.
- 4) Some important parameters, such as heat flow and fluid velocity vector fields are difficult to directly observe on any scale.
- 5) The cost of fabrication of experimental nozzles is high.

15

[0155] Computer simulation overcomes the above problems. A leading software package for fluid dynamics simulation is FIDAP, produced by Fluid Dynamics International Inc. of Illinois, USA (FDI). FIDAP is a registered trademark of FDI. Other simulation programs are commercially available, but FIDAP was chosen for its high accuracy in transient fluid dynamic, energy transport, and surface tension calculations. The version of FIDAP used is FIDAP 7.06.

20

Theoretical basis of calculations

[0156] The theoretical basis for fluid dynamic and energy transport calculations using the Finite Element Method, and the manner that this theoretical basis is applied to the FIDAP computer program, is described in detail in the FIDAP 7.0 Theory Manual (April 1993) published by FDI, the disclosure of which is hereby incorporated by reference.

25

Material characteristics

[0157] The table "Properties of materials used for FIDAP simulation" gives approximate physical properties of materials which may be used in the fabrication of the print head.

[0158] The properties of 'ink' used in this simulation are actually the properties of pure water. This is to simulate a 'worst case' situation for drop separation, where the surface tension of the ink reduces only very slightly with temperature. Much wider operating margins can be achieved by using inks especially formulated to have a large decrease in surface tension with temperature.

35

[0159] To obtain convergence for transient free surface simulations with variable surface tension at micrometer scales with microsecond transients using FIDAP 7.06, it is necessary to nondimensionalize the simulation.

[0160] The values which have been used in the example simulation using the FIDAP program are shown in the table "Properties of materials used for FIDAP simulation". Most values are from CRC Handbook of Chemistry and Physics, 72nd edition, or Lange's handbook of chemistry, 14th edition.

40

45

50

55

*Properties of materials used for FIDAP simulation*

Property		Physical value (SI units)	Dimension- less value
Characteristic length (L)	All	10 <sup>-6</sup> m	1
Characteristic velocity (U)	Ink	1 m/s	1
Characteristic time	All	10 <sup>-6</sup> s	1
Time step	All	10 <sup>-7</sup> s	0.1
Ambient temperature	All	303.15 °K	30
Boiling point	Ink	376.15 °K	103
Energy density scale factor	Heater	4.216 x 10 <sup>14</sup> m <sup>-3</sup>	668
Viscosity (η)	At 20°C	10.02 x 10 <sup>-4</sup> Pa s	1.536
	At 30°C	7.977 x 10 <sup>-4</sup> Pa s	1.416
	At 40°C	6.534 x 10 <sup>-4</sup> Pa s	1
	At 50°C	5.470 x 10 <sup>-4</sup> Pa s	0.837
	At 60°C	4.665 x 10 <sup>-4</sup> Pa s	0.714
	At 70°C	4.040 x 10 <sup>-4</sup> Pa s	0.618

	At 100°C	$2.818 \times 10^{-4} \text{ Pa s}$	0.431	
5	Surface tension ( $\gamma$ )	At 20°C	$0.0728 \text{ N m}^{-1}$	111.4
		At 30°C	$0.0712 \text{ N m}^{-1}$	108.9
		At 40°C	$0.0696 \text{ N m}^{-1}$	106.5
10		At 50°C	$0.0679 \text{ N m}^{-1}$	103.9
		At 60°C	$0.0662 \text{ N m}^{-1}$	101.3
		At 70°C	$0.0645 \text{ N m}^{-1}$	98.7
15		At 100°C	$0.0589 \text{ N m}^{-1}$	90.1
	Coefficient of surface tension ( $\gamma_T$ )	At 40°C	$0.0728 \text{ N m}^{-1} \text{ K}^{-1}$	$-1.7 \times 10^{-4}$
20	Pressure ( $p$ )	Ink	10,000 Pa	15.3
	Thermal Conductivity ( $k$ )	Ink	$0.631 \text{ W m}^{-1} \text{ K}^{-1}$	1
		Crystalline silicon	$148 \text{ W m}^{-1} \text{ K}^{-1}$	234.5
25		Amorphous $\text{SiO}_2$	$1.5 \text{ W m}^{-1} \text{ K}^{-1}$	2.377
		TaAl	$23 \text{ W m}^{-1} \text{ K}^{-1}$	36.45
		Tantalum	$57.5 \text{ W m}^{-1} \text{ K}^{-1}$	91.13
30		$\text{Si}_3\text{N}_4$	$19 \text{ W m}^{-1} \text{ K}^{-1}$	30.11
	Specific heat ( $c_p$ )	Ink	$3,727 \text{ J kg}^{-1} \text{ K}^{-1}$	3.8593
35		Crystalline silicon	$711 \text{ J kg}^{-1} \text{ K}^{-1}$	0.7362
		Amorphous $\text{SiO}_2$	$738 \text{ J kg}^{-1} \text{ K}^{-1}$	0.7642
40		TaAl	$250 \text{ J kg}^{-1} \text{ K}^{-1}$	0.2589
		Tantalum	$138 \text{ J kg}^{-1} \text{ K}^{-1}$	0.1429
		$\text{Si}_3\text{N}_4$	$712 \text{ J kg}^{-1} \text{ K}^{-1}$	0.7373
45	Density ( $\rho$ )	Ink	$1,036 \text{ kg m}^{-3}$	1.5856
		Crystalline silicon	$2,320 \text{ kg m}^{-3}$	3.551
50		Amorphous $\text{SiO}_2$	$2,190 \text{ kg m}^{-3}$	3.352
		TaAl	$10,500 \text{ kg m}^{-3}$	16.07

	Tantalum	16,600 kg m <sup>-3</sup>	25.41
	Si <sub>3</sub> N <sub>4</sub>	3,160 kg m <sup>-3</sup>	4.836

5

10 Fluid dynamic simulations of nozzles

[0161] Print heads can be designed to operate over a wide range of conditions, and at various print resolutions. Most currently available mass-market drop on demand printing systems have a printing resolution of between 300 and 400 dpi. This is not an absolute limit for thermal ink jet designs, but as the print resolution increases the print head design typically becomes progressively more difficult. Print heads can be designed with a wide range of print resolutions, but most of the volume market is likely to be between resolutions of 400 dpi and 800 dpi. 400 dpi bi-level printing is generally adequate for text and graphics, but is not adequate for high quality full color photographic reproduction. An exception to this is when printing on cloth, where 400 dpi printing can give results superior to standard cloth. This is because the major limitation on print quality on cloth using mechanical printing techniques is registration, as it is difficult to prevent the cloth from stretching and distorting between each printed color. 800 dpi is likely to be the maximum requirement for mass market printing systems, as 800 dpi 6 color CMYK printing using stochastic screening can yield results approximately equivalent to the print quality that people are accustomed to from 133 to 150 lpi color offset printing.

15

20

Self-Cooling Operation in Thermally Activated Printing Heads

25

[0162] The current invention provides a system for eliminating or significantly reducing the problem of waste heat removal, allowing print heads with higher speed, smaller size, lower cost, and a greater number of nozzles to be constructed.

30

[0163] This system relies upon the ejected ink itself to remove waste heat and provides for the print head to be designed following two constraints:

- 1) The quiescent power consumption (power consumed by the print head when not actually printing) should be low enough so that dissipation of quiescent heat can be achieved by convection or forced air cooling.
- 2) The maximum active power consumption (power consumed when printing) should be less than the power required to raise the temperature of the ink which is being printed above the a reliable operating temperature.

35

[0164] The first constraint can be met by using CMOS driving circuitry. In most circumstances, the use of CMOS driving circuitry results in quiescent power that is so low that it can be dissipated without requiring a heatsink or other special arrangements. Bipolar, nMOS or other driving circuitry can also be used, as long as the thermal resistance from the print head to the ambient environment is low enough to prevent excessive heat accumulation. However, current thermal ink-jet (TIJ) printing systems have an active power requirement which is too high to allow the practical use of CMOS or nMOS circuitry. Therefore, bipolar drive circuitry is typically used. Print heads using this invention's printing technology can be designed with sufficiently low active power consumption (less than 1% of TIJ) as to make the use of CMOS drive circuitry practical.

45

[0165] The second constraint can be met by designing the nozzles of the print head so that the energy required to eject a single drop is less than the energy required to raise an equivalent volume of ink from the ambient ink temperature to the maximum ink temperature where reliable printing operation is maintained. If this is achieved, then the full amount of the active power can be dissipated in the printed ink itself.

50

[0166] The amount of active power consumption is directly proportional to the number of ink drops printed per unit time. The power that can be dissipated in the printed ink is also directly proportional to the number of ink drops printed per unit time. Therefore, if the energy per drop can be reduced below the required threshold, the constraint that power dissipation places on print speed, number of nozzles, or nozzle density can be completely removed, and "self-cooling operation" is achieved.

55

[0167] The value of the self cooling threshold depends upon the ambient temperature, the ink drop radius, the specific heat capacity of the ink, the boiling point of the ink, and the operating margin required.

[0168] Commercially available thermal ink jet printing technologies currently have a drop ejection energy approximately ten times the threshold for self-cooling operation. It is likely that self-cooling operation is very difficult to achieve for thermal ink jet printers with drop sizes less than 100 pl.

[0169] However, the nozzles of print heads operating in accordance with the present invention can readily be designed for self-cooling operation.

#### Preferred Embodiment Using Viscosity Reduction Selection

5

[0170] In this preferred embodiment, the means of selecting drops to be printed is the thermal reduction of ink viscosity in the presence of oscillating ink pressure. The average pressure of the oscillating ink pressure is insufficient to overcome the surface tension of the ink and eject ink from the nozzle. At ambient temperature, the ink viscosity is such that the amplitude of ink meniscus oscillation resulting from the oscillation in ink pressure is insufficient to result in drop separation. When the thermal actuator of a nozzle is activated, the ink viscosity falls sufficiently that the amplitude of ink meniscus oscillation resulting from the oscillation in ink pressure is sufficient to result in drop separation.

10

[0171] In most instances, the velocity of the ink as it emerges from the nozzle will not be sufficient to cause the emerging ink drop to separate from the body of ink. For most drop sizes of interest in computer controlled printing, the force of gravity on the drop is insignificant compared to the surface tension forces, so gravity cannot be used as a means of drop separation.

15

[0172] Therefore, a means of separating the selected drop from the body of ink, and ensuring that the selected drop proceeds to form a spot on the recording medium, is required. The ink drop separation means may be chosen from, but is not limited to, the following list:

20

- 1) Proximity (recording medium in close proximity to print head)
- 2) Electrostatic attraction
- 3) Magnetic attraction

[0173] For effective operation, the ink should exhibit a large reduction in viscosity with temperature. The viscosity of the ink should be high (preferably in excess of 20 cP) for drops which are not selected, and should fall by a factor which is preferably in excess of 10 for selected drops. Appropriate ink properties can be achieved using mixtures various organic waxes, acids, alcohols, oils and other compounds.

25

[0174] Viscous printing in accordance with the invention is suitable for hot melt printing, where the ink is solid at room temperature. The ink preferably has a melting point above 60°C, and can also be formulated as a mixture of compounds with different melting points, so that it 'softens' rather than having a distinct melting point. The ink reservoir and printing head are elevated to a temperature above the melting point of the ink (for example, 80°C) prior to printing. This temperature is referred to as the quiescent temperature. The temperature of the print head can be regulated to minimize the influence of ambient temperature on the printing characteristics.

30

[0175] When a drop is to be printed, an electrothermal actuator in the nozzle is activated, raising the temperature of the ink at the nozzle tip. A suitable ejection temperature may be 100°C above the quiescent temperature, allowing sufficient temperature difference to result in a large reduction in viscosity. For high speed high resolution printing, the viscosity of the ink at the ejection temperature is preferably less than 10 cP, and more preferably in the order of 1 cP. The low viscosity results in the ink moving much more rapidly in response to the oscillating ink pressure, which in turn results in the ink moving further.

35

[0176] The reduced viscosity results in selected drops having a peak meniscus position which is further extended from the nozzle than the peak meniscus position of drops which are not selected. This allows the drop separation means to discriminate between selected drops and drops which have not been selected.

40

[0177] The oscillating ink pressure can be achieved by applying an acoustic wave to the ink. The waveshape is not critical, but a sinusoidal wave is the simplest to control and predict, and so is assumed herein. The frequency is the same as, or an integral multiple of, the drop ejection frequency from a single nozzle. The phase of the oscillation is preferably accurately timed in relation to the drop ejection cycle.

45

[0178] An apparatus to cause the acoustic wave includes a piezoelectric crystal the entire length of the row of nozzles situated in such a way as to cause displacement of the body of ink in the ink channel supplying the row of nozzles. A sinusoidal voltage of the appropriate frequency, amplitude and phase is applied to the piezoelectric crystal. The piezoelectric crystal expands or contracts in response to the applied voltage, causing displacement of the ink. As the displacement is dynamic and continuous, pressure waves form in the ink.

50

[0179] Because the addition of acoustic ink waves adds complexity and expense to printing, it is most applicable to those applications which are not highly cost sensitive. Such applications include short run digital color printing, and high quality high speed color office printing.

55

#### Viscous Operation

[0180] The exact operation of printing in accordance with this invention using viscosity reduction is dependent upon

many factors, many of which can be accurately controlled during the print head manufacturing process, ink manufacturing, or during printer operation. These factors include:

- 1) Nozzle radius
- 2) Nozzle length
- 3) Barrel geometry
- 4) Ink pressure period
- 5) Ink pressure wave amplitude
- 6) Constant offset in ink pressure
- 7) Phase of heater actuation pulse relative to ink pressure wave
- 8) Energy of heat pulse
- 9) Energy distribution of heat pulse with respect to time
- 10) Heater geometry
- 11) Heater position relative to nozzle
- 12) Thermal conductivity of nozzle materials
- 13) Thermal conductivity of ink
- 14) Ink viscosity with respect to temperature

#### Computer simulations of nozzle dynamics

**[0181]** Details of the operation print heads have been extensively simulated by computer. Figures 7 to 15 are some results from an example simulation of invention embodiment nozzle operation using electrothermal drop selection by reduction in viscosity. The drop separation means is not modeled in these simulations. As a result, the selected drop is not separated from the body of ink, and returns to the nozzle. To produce an operational drop on demand printer, the drop selection means as modeled herein must be combined with a suitable drop separation means.

**[0182]** Computer simulation is extremely useful in determining the characteristics of phenomena which are difficult to observe directly. Nozzle operation is difficult to observe experimentally for several reasons, including:

- 1) Useful nozzles in accordance with the invention are microscopic, with important phenomena occurring at dimensions of order 1  $\mu\text{m}$ .
- 2) The time scale of a drop ejection is a few microseconds, requiring very high speed observations.
- 3) Important phenomena occur inside opaque solid materials, making direct optical observation impossible.
- 4) Some important parameters, such as heat flow, viscosity, and fluid velocity are difficult to directly observe.
- 5) The cost of fabrication of experimental nozzles is high.

**[0183]** Computer simulation overcomes the above problems. A leading software package for fluid dynamics simulation is FIDAP, produced by Fluid Dynamics International Inc. of Illinois, USA (FDI). FIDAP is a registered trademark of FDI. Other simulation programs are commercially available, but FIDAP was chosen for its high accuracy in transient fluid dynamic, energy transport, and surface tension calculations. The version of FIDAP used is FIDAP 7.06.

#### Theoretical basis of calculations

**[0184]** The theoretical basis for fluid dynamic and energy transport calculations using the Finite Element Method, and the manner that this theoretical basis is applied to the FIDAP computer program, is described in detail in the FIDAP 7.0 Theory Manual (April 1993) published by FDI.

#### Material characteristics

**[0185]** The table "Properties of materials used for FIDAP simulation" gives approximate physical properties of materials which may be used in the fabrication of the print head.

**[0186]** The properties of 'ink' used in this simulation are estimates for a hot melt black ink containing a solid pigment dispersed in a vehicle comprising a mixture of  $\text{C}_{18}$ - $\text{C}_{24}$  acids or alcohols and/or appropriate waxes with melting points between 60°C and 80°C. At the ambient temperature of the simulation (80°C), the vehicle is liquid, with a viscosity of approximately 100 cP. The viscosity values for the hot melt ink do not represent any particular formulation, but rather a recommended target viscosity curve. The black colorant is 2% Acheson graphite with a particle size less than 10  $\mu\text{m}$ . The graphite provides an intense black colorant with excellent stability and lightfastness, as well as increasing the thermal conductivity of the ink. Acheson graphite has a thermal conductivity of 150  $\text{W m}^{-1} \text{K}^{-1}$  parallel to the axis of extrusion, and 111  $\text{W m}^{-1} \text{K}^{-1}$  normal to the axis of extrusion at 100°C. Inclusion of graphite as the colorant increases the

thermal conductivity of the ink vehicle. This is important, as a relatively high thermal conductivity is desirable for high speed and low power operation. If the colorant chosen does not have a high thermal conductivity, and the ink vehicle has a low thermal conductivity, then additives to increase the thermal conductivity to at least  $0.5 \text{ W m}^{-1} \text{ K}^{-1}$  are recommended for high speed printers.

5 **[0187]** To obtain convergence for transient free surface simulations with variable surface tension at micrometer scales with microsecond transients using FIDAP 7.06, it is necessary to nondimensionalize the simulation.

**[0188]** The values which have been used in the example simulation using the FIDAP program are shown in the table "Properties of materials used for FIDAP simulation". Most values are from CRC Handbook of Chemistry and Physics, 72nd edition, or Lange's handbook of chemistry, 14th edition.

10

15

20

25

30

35

40

45

50

55

<i>Properties of materials used for FIDAP simulation</i>			
Property		Physical value	Dimensionless value
Characteristic length (L)	All	1 $\mu\text{m}$	1
Characteristic velocity (U)	Ink	1 $\text{m s}^{-1}$	1
Characteristic time	All	1 $\mu\text{s}$	1
Quiescent temperature	All	80°C	80
Viscosity ( $\eta$ )	At 80°C	100 cP	153
	At 100°C	10 cP	15.3
	At 120°C	2 cP	3.06
	At 140°C	1.5 cP	2.29
	At 160°C	1.2 cP	1.84
Surface tension ( $\gamma$ )	At 20°C	27 $\text{mN m}^{-1}$	41.3
	At 80°C	22 $\text{mN m}^{-1}$	33.7
	At 160°C	18 $\text{mN m}^{-1}$	27.6
Pressure cycle period	Ink	72 $\mu\text{s}$	72
Actuation pulse duration	Heater	36 $\mu\text{s}$	36
Thermal Conductivity ( $k$ )	Ink (2% Graphite)	2.6 $\text{W m}^{-1} \text{K}^{-1}$	4.12
	Crystalline silicon	148 $\text{W m}^{-1} \text{K}^{-1}$	234.5
	Amorphous $\text{SiO}_2$	1.5 $\text{W m}^{-1} \text{K}^{-1}$	2.377
	Heater	23 $\text{W m}^{-1} \text{K}^{-1}$	36.45
	$\text{Si}_3\text{N}_4$	19 $\text{W m}^{-1} \text{K}^{-1}$	30.11
Specific heat ( $c_p$ )	Ink	2,000 $\text{J kg}^{-1} \text{K}^{-1}$	2.071
	Crystalline silicon	711 $\text{J kg}^{-1} \text{K}^{-1}$	0.7362
	Amorphous $\text{SiO}_2$	738 $\text{J kg}^{-1} \text{K}^{-1}$	0.7642
	Heater	250 $\text{J kg}^{-1} \text{K}^{-1}$	0.2589
	$\text{Si}_3\text{N}_4$	712 $\text{J kg}^{-1} \text{K}^{-1}$	0.7373
Density ( $\rho$ )	Ink	0.9 $\text{g cm}^{-3}$	1.38
	Crystalline silicon	2.32 $\text{g cm}^{-3}$	3.551
	Amorphous $\text{SiO}_2$	2.19 $\text{g cm}^{-3}$	3.352
	Heater	10.5 $\text{g cm}^{-3}$	16.07

(continued)

<i>Properties of materials used for FIDAP simulation</i>			
Property		Physical value	Dimensionless value
	Si <sub>3</sub> N <sub>4</sub>	3.16 g cm <sup>-3</sup>	4.836

### Results of fluid dynamic simulations

- 10 **[0189]** Figures 10(a) to 10(j) are plots of an example nozzle from a combined thermal and fluid dynamic simulation. Axi-symmetric simulation is used, as the example nozzle is cylindrical in form. There are five deviations from cylindrical form. These are the connections to the heater, the laminar air flow caused by paper movement, gravity (if the printhead is not vertical), the geometry of the nozzle barrel more than 25  $\mu\text{m}$  from the axis of symmetry, and the presence of adjacent nozzles in the substrate. The effect of these factors on drop ejection is minor.
- 15 **[0190]** Figure 7 is a graph of ink pressure as a function of time. The pressure varies sinusoidally with a period of 72  $\mu\text{s}$ . Three pressure cycles are shown. The horizontal axis is in units of 100  $\mu\text{s}$ , from 0  $\mu\text{s}$  to 216  $\mu\text{s}$ .
- [0191]** Figure 8 shows the temperature at various points in the nozzle as a function of time, with an electrothermal pulse applied during the third cycle of figure 7. The pulse starts at 16  $\mu\text{s}$ , and has a duration of 36  $\mu\text{s}$ . The pulse is shaped top maintain the temperature at the nozzle tip (where the ink meniscus meets the nozzle) approximately constant at 180°C for the duration of the pulse. This is shown by the curve B. The curve A shows the temperature at the centre of the heater. The curve C shows the temperature at a point on the surface of the print head 14.5  $\mu\text{m}$  from the heater. The horizontal axis is identical to that of figure 20. The vertical axis is in units of 100°C. The ambient temperature is 80°C. Figure 9 shows
- 20 **[0192]** the position of the meniscus extremum as a function of time. The horizontal axis is identical to that of figure 7. The first two cycles (0  $\mu\text{s}$  to 144  $\mu\text{s}$ ) show unselected drops, where the heater is not energized. In this case, the temperature is low and the viscosity is high (100 cP). The high viscosity results in a small motion (approximately 2  $\mu\text{m}$  peak to peak) in response to the pressure variations shown in figure 7. During the third cycle of the pressure wave, the heater is energized, resulting in the temperature increase shown in figure 8. The reduced viscosity results in a meniscus movement of approximately 10  $\mu\text{m}$ . The difference in meniscus position between the unselected drops and the selected drops allows the drop separation means to ensure that selected drops proceed to form spots on the recording medium, and unselected drops do not. The drop separation means is not modeled in this simulation, and therefore the selected drop moves back into the nozzle. This can be seen in figure 9 during the period from 196  $\mu\text{s}$  to 216  $\mu\text{s}$ .
- 25 **[0193]** Figures 10(a)-10(j), 11, 12, 14 and 15 show cross sections of a nozzle during operation. Only the region in the tip of the nozzle is shown, as most phenomena relevant to drop selection occur in this region. These plots show a cross section of the nozzle tip, from the axis of symmetry out to a distance of 22  $\mu\text{m}$ . The nozzle radius is 10  $\mu\text{m}$ , and the plots are to scale. In these figures 100 is ink, 101 is the silicon substrate, 102 is SiO<sub>2</sub>, 103 marks the position of one side of the annular heater, 108 is a Si<sub>3</sub>N<sub>4</sub> passivation layer and 109 is lipophobic surface coating.
- 30 **[0194]** Figures 10(a), 10(c), 10(e), 10(g) and 10(i) show thermal contours at 5°C intervals. Figures 10(b), 10(d), 10(f), 10(h) and 10(j) show viscosity contours and drop evolution at various times during a drop ejection cycle.
- 35 **[0195]** Figure 10(a) shows the temperature contours at the start of the heater energizing pulse, at a time of 160  $\mu\text{s}$  as shown in figures 20 to 22. The power applied to the heater at this time is 180 mW. The ambient temperature is 80°C, and temperature contours are shown at 5°C intervals from 85°C to 120°C.
- [0196]** Figure 10(b) shows the viscosity contours at a time of 160  $\mu\text{s}$ . The bulk ink viscosity is 100 cP, and there is little variation in viscosity at this time. The lines in the solid materials (silicon 101, SiO<sub>2</sub> 102, and Si<sub>3</sub>N<sub>4</sub> 108) show the finite element calculation mesh.
- 40 **[0197]** Figure 10(c) shows the temperature contours 10  $\mu\text{s}$  after the start of the heater energizing pulse, at a time of 170  $\mu\text{s}$ . The power applied to the heater at this time is 74 mW. Temperature contours are shown at 5°C intervals from 85°C to 195°C.
- [0198]** Figure 10(d) shows the viscosity contours at a time of 170  $\mu\text{s}$ . The ink viscosity varies from 100 cP away from the heater to below 2 cP near the heater.
- 45 **[0199]** Figure 10(e) shows the temperature contours 20  $\mu\text{s}$  after the start of the heater energizing pulse, at a time of 180  $\mu\text{s}$ . The power applied to the heater at this time is 60 mW.
- [0200]** Figure 10(f) shows the viscosity contours at a time of 180  $\mu\text{s}$ . The reduced ink velocity has allowed the increase in ink pressure to move the ink further than it would have moved had the heater not been energized. The viscosity is lowest at the walls of the nozzle tip, where the temperature is highest. This aids in the movement of the ink, as the retarding effect of ink viscosity on ink movement is greater near the walls of the nozzle than at the axis of the nozzle.
- 50 **[0201]** Figure 10(g) shows the temperature contours 30  $\mu\text{s}$  after the start of the heater energizing pulse, at a time of 190  $\mu\text{s}$ . The power applied to the heater at this time is 58 mW.

[0202] Figure 10(h) shows the viscosity contours at a time of 190  $\mu\text{s}$ . The 'crinkling' of the viscosity contour (especially visible on the 4 cP contour) is a calculation artifact of the finite element simulation, resulting from interpolation within elements combined with the non-linear relationship between temperature and viscosity. The effect of this interpolation on the simulation is negligible.

5 [0203] Figure 10(i) shows the temperature contours 40  $\mu\text{s}$  after the start of the heater energizing pulse, at a time of 200  $\mu\text{s}$ . This is 4  $\mu\text{s}$  after the heater has been turned off, and the maximum temperature at this stage is 155°C.

[0204] Figure 10(j) shows the viscosity contours at a time of 200  $\mu\text{s}$ . At this stage, the drop separation means would become the major factor determining meniscus position. Most of the high temperature, low viscosity ink proceeds to form the selected drop and produce a spot on the recording medium. The reduced viscosity and elevated temperature

10 of the selected drop aids in binding the drop to the fibers of a fibrous recording medium before the drop freezes. [0205] Figure 11 shows the movement of meniscus position during a cycle when the ink drop is not selected. Ink meniscus positions at 10  $\mu\text{s}$  intervals from 88  $\mu\text{s}$  to 128  $\mu\text{s}$  are shown. These correspond to the same phases of the ink pressure wave as the intervals from 160  $\mu\text{s}$  to 200  $\mu\text{s}$  shown in figure 12. The meniscus moves approximately 2  $\mu\text{m}$  in response to the oscillating pressure.

15 [0206] Figure 12 shows the movement of meniscus position during a drop selection cycle. Ink meniscus positions at 10  $\mu\text{s}$  intervals from 160  $\mu\text{s}$  to 200  $\mu\text{s}$  are shown. These correspond to the same phases of the ink pressure wave as the intervals from 88  $\mu\text{s}$  to 128  $\mu\text{s}$  shown in figure 11. The meniscus moves approximately 10  $\mu\text{m}$  in response to the oscillating pressure, due to the lower viscosity of the heated ink.

[0207] Figure 13 shows the position of the meniscus extremum as a function of time for a simulation in which the frequency of the ink pressure wave, and frequency of drop selection and separation are halved. The maximum printing rate of this arrangement is one half that of arrangement for which simulation results are shown in figures 10(a) to 10(j). However, the absolute difference in position between unselected drops and selected drops is greater, providing an increased operating margin for the drop separation process. The horizontal axis is similar to that of figure 9, but the time axis is expanded by a factor of two. The vertical scale of this graph is different from that of figure 9. The first two cycles (0  $\mu\text{s}$  to 288  $\mu\text{s}$ ) show unselected drops, where the heater is not energized. In this case, the temperature is low and the viscosity is high (100 cP). The high viscosity results in a small motion (approximately 4  $\mu\text{m}$  peak to peak) in response to the pressure variations with a period of 144  $\mu\text{s}$ . During the third cycle of the pressure wave, the heater is energized. The reduced viscosity results in a meniscus movement of approximately 15  $\mu\text{m}$ . The drop separation means is not modeled in this simulation, and therefore the selected drop moves back into the nozzle. This can be seen in figure 13 during the period from 392  $\mu\text{s}$  to 432  $\mu\text{s}$ .

20 [0208] Figure 14 shows the movement of meniscus position during a cycle when the ink drop is not selected. Ink meniscus positions at 20  $\mu\text{s}$  intervals from 176  $\mu\text{s}$  to 256  $\mu\text{s}$  are shown. These correspond to the same phases of the ink pressure wave as the intervals from 320  $\mu\text{s}$  to 400  $\mu\text{s}$  shown in figure 15. The meniscus moves approximately 4  $\mu\text{m}$  in response to the oscillating pressure.

25 [0209] Figure 15 shows the movement of meniscus position during a drop selection cycle. Ink meniscus positions at 20  $\mu\text{s}$  intervals from 320  $\mu\text{s}$  to 400  $\mu\text{s}$  are shown. These correspond to the same phases of the ink pressure wave as the intervals from 176  $\mu\text{s}$  to 256  $\mu\text{s}$  shown in figure 14. The meniscus moves approximately 16  $\mu\text{m}$  in response to the oscillating pressure, due to the lower viscosity of the heated ink.

30 [0210] The nozzles for which simulation results are shown in figure 7 to 15 are of a different design than the nozzles shown in figures 1 and 2. There are many possible designs for nozzles for print heads. As the fundamental requirements of a nozzle are somewhat simpler than the requirements of a thermal ink jet nozzle, the actual geometry chosen for the nozzle can largely be determined for convenience in the manufacturing process.

#### Variable drop size

45 [0211] Several mechanisms may be used to achieve variable drop size, to allow operation as a contone printer instead of a bi-level printer. The range of drop size variation will depend upon the exact characteristics of the print head, drive circuitry, drop separation means, and ink used.

[0212] Means of achieving modulation of drop size on a drop-by-drop basis include:

- 50 1) Modulation of the time of the leading edge of the heater pulse, maintaining the trailing edge constant.
- 2) Modulation of the time of the trailing edge of the heater pulse, maintaining the leading edge constant.
- 3) Modulation of the time of the leading edge of the heater pulse, maintaining the pulse width constant.
- 4) Modulation of the voltage of the heater pulse.

55 [0213] The foregoing describes various general and preferred embodiments of the present invention. Characteristics of one detailed preferred embodiment are set forth in the tables of Appendix A. Modifications, obvious to those skilled in the art, can be made to the general and specific embodiments without departing from the scope of the claims.

# Appendix A

5

## Monolithic LIFT head type A4-4-600

This is a four color print head for A4 size printing. The print head is fixed, and is the full width of the A4 paper. Resolution is 600 dpi bi-level for medium quality output.

10

### Basic specifications

### Derivation

15

20

25

30

Resolution..... 600 dpi	<i>Specification</i>
Print head length..... 215 mm	<i>Width of print area, plus 5 mm</i>
Print head width..... 5 mm	<i>Derived from physical and layout constraints of head</i>
Ink colors..... 4	<i>CMYK</i>
Page size..... A4	<i>Specification</i>
Print area width..... 210 mm	<i>Pixels per line / Resolution</i>
Print area length..... 297 mm	<i>Total length of active printing</i>
Page printing time..... 1.3 seconds	<i>Derived from fluid dynamics, number of nozzles, etc.</i>
Pages per minute..... 45 ppm	<i>Per head, for full page size</i>
Recording medium speed..... 22.0 cm/sec	<i>1/(resolution * actuation period times phases)</i>
Basic IC process..... 1.5 $\mu$ m CMOS	<i>Recommendation</i>
Bitmap memory requirement..... 16.6 MBytes	<i>Memory required when compression is not used</i>
Pixel spacing..... 42.33 $\mu$ m	<i>Reciprocal of resolution</i>
Pixels per line..... 4,960	<i>Active nozzles / Number of colors</i>
Lines per page..... 7,015	<i>Scan distance * resolution</i>
Pixels per page..... 34,794,400	<i>Pixels per line * lines per page</i>
Drops per page..... 139,177,600	<i>Pixels per page * simultaneous ink colors</i>
Average data rate..... 12.3 MByte/sec	<i>Pixels per second * ink colors / 8 MBits</i>

35

### Yield and cost

### Derivation

40

45

50

Number of chips per head..... 1	<i>Recommendation</i>
Wafer size..... 300 mm (12")	<i>Recommendation for full volume production</i>
Chips per wafer..... 36	<i>From chip size and recommended wafer size</i>
Print head chip area..... 10.7 cm <sup>2</sup>	<i>Chip width * length</i>
Sort yield without fault tolerance..... 0.87%	<i>Using Murphy's method, defect density = 1 per cm<sup>2</sup></i>
Sort yield with fault tolerance..... 90%	<i>See fault tolerant yield calculations (D=1/cm<sup>2</sup>, CF=2)</i>
Total yield with fault tolerance..... 72%	<i>Based on mature process yield of 80%</i>
Functional print heads per month..... 260,208	<i>Assuming 10,000 wafer starts per month</i>
Print head assembly cost..... \$10	<i>Estimate</i>
Factory overhead per print head..... \$13	<i>Based on \$120m. cost for refurbished 1.5 <math>\mu</math>m Fab line amortised over 5 years, plus \$16m. P.A. operating cost</i>
Wafer cost per print head..... \$23	<i>Based on materials cost of \$600 per wafer .</i>
Approx. total print head cost..... \$46	<i>Sum of print head assembly, overhead, and wafer costs</i>

55

## Appendix A (cont'd.)

<b>Monolithic LIFT head type A4-4-600</b>		
<b>Nozzle and actuation specifications</b>	<b>Derivation</b>	
Nozzle radius..... 14 $\mu\text{m}$	<i>Specification</i>	
Number of actuation phases..... 8	<i>Specification</i>	
Nozzles per phase..... 2,480	<i>From page width, resolution and colors</i>	
Active nozzles per head..... 19,840	<i>Actuation phases * nozzles per phase</i>	
Redundant nozzles per head..... 19,840	<i>Same as active nozzles for 100% redundancy</i>	
Total nozzles per head..... 39,680	<i>Active plus redundant nozzles</i>	
Drop rate per nozzle..... 5,208 Hz	<i>1/(heater active period * number of phases)</i>	
Heater radius..... 14.5 $\mu\text{m}$	<i>From nozzle geometry and radius</i>	
Heater thin film resistivity..... 2.3 $\mu\Omega\text{m}$	<i>For heater formed from TaAl</i>	
Heater resistance..... 2,095 $\Omega$	<i>From heater dimensions and resistivity</i>	
Average heater pulse current..... 5.6 mA	<i>From heater power and resistance</i>	
Heater active period..... 24 $\mu\text{s}$	<i>From finite element simulations</i>	
Settling time between pulses..... 168 $\mu\text{s}$	<i>Active period * (actuation phases-1)</i>	
Clock pulses per line..... 2,834	<i>Assuming multiple clocks and no transfer register</i>	
Clock frequency..... 14.8 MHz	<i>From clock pulses per line, and lines per second</i>	
Drive transistor on resistance..... 42 $\Omega$	<i>From recommended device geometry</i>	
Average head drive voltage..... 12.0 V	<i>Heater current * (heater +drive transistor resistance)</i>	
Drop selection temperature..... 75 $^{\circ}\text{C}$	<i>m.p. of surfactant sol or PIT of microemulsion</i>	
Heater peak temperature..... 120 $^{\circ}\text{C}$	<i>From finite element simulations</i>	
<b>Ink specifications</b>	<b>Derivation</b>	
Basic ink carrier..... Water	<i>Specification</i>	
Surfactant..... Arachidic acid	<i>Suggested method of achieving temperature threshold</i>	
Ink drop volume..... 18 pl	<i>From finite element simulations</i>	
Ink density..... 1.030 $\text{g}/\text{cm}^3$	<i>Black ink density at 60<math>^{\circ}\text{C}</math></i>	
Ink drop mass..... 18.5 ng	<i>Ink drop volume * ink density</i>	
Ink specific heat capacity..... 4.2 J/Kg $^{\circ}\text{C}$	<i>Ink carrier characteristic</i>	
Max. energy for self cooling..... 2,715 nJ/drop	<i>Ink drop heat capacity * temperature increase</i>	
Ejection energy per drop..... 1,587 nJ	<i>Energy applied to heater in finite element simulations</i>	
Energy to print full black page..... 221 J	<i>Drop ejection energy * drops per page</i>	
Total ink per color per page..... 0.63 ml	<i>Drops per page per color * drop volume</i>	
Maximum ink flow rate per color..... 0.47 ml/sec	<i>Ink per color per page / page print time</i>	
Full black ink coverage..... 40.2 $\text{ml}/\text{m}^2$	<i>Ink drop volume * colors * drops per square metre</i>	
Ejection ink surface tension..... 38.5 mN/m	<i>Surface tension required for ejection</i>	
Ink pressure..... 5.5 kPa	<i>2 * Ejection ink surface tension / nozzle radius</i>	
Ink column height..... 545 mm	<i>Ink column height to achieve ink pressure</i>	

**Claims**

1. A drop-on-demand printing system comprising an ink (100) that is magnetically or electrically attractable and a printer with a print head (50), the print head having nozzles (59) and means for subjecting ink (100) in the nozzles (59) to pressure which is at least periodically above ambient air pressure to form a meniscus, said, print head (50) incorporating an electrically controlled actuator (56-58) which acts on the surface of the meniscus to select a drop by reducing the surface tension or viscosity of said drop sufficiently so that the meniscus of said selected drop moves, under said pressure, to a different position than the meniscus of unselected drops, and a drop separation apparatus (74) for attracting the selected drop from the printer to a recording medium (51).
2. The system as claimed in claim 1 where said electrically controlled actuator (56-58) applies heat to the tip of selected nozzles (59).
3. The system as claimed in claim 2 where the electrically controlled actuator (56-58) is an electrothermal actuator.
4. The system as claimed in claim 1 where the drop separation means is an electric field acting on electrically conductive ink (100).
5. The system as claimed in claim 1 where the drop separation means (74) is a magnetic field acting on liquid ink (100) which contains magnetically active particles.
6. The drop on demand printing apparatus as claimed in claim 1 wherein said means for subjecting ink (100) to pressure is adapted to apply pressure varying in a cyclic manner.
7. The drop on demand printing system as claimed in claim 6 wherein said variations in ink (100) pressure are produced by a piezoelectric device to which is applied to a varying voltage.

**Patentansprüche**

1. Drop-on-demand Drucksystem mit einer Tinte (100), die magnetisch oder elektrisch anziehbar ist, und mit einem Drucker mit Druckkopf (50), der Düsen (59) umfaßt und Mittel, die die Tinte (100) in den Düsen (59) einem Druck aussetzen, der mindestens periodisch über dem umgebenden Luftdruck liegt, um einen Meniskus zu bilden, wobei der Druckkopf (50) eine elektrisch gesteuerte Betätigungsverrichtung (56 - 58) aufweist, die auf die Oberfläche des Meniskus einwirkt, um einen Tropfen durch ausreichende Reduzierung der Oberflächenspannung oder -viskosität des Tropfens auszuwählen, so daß sich der Meniskus des ausgewählten Tropfens unter dem Druck in eine andere Position bewegt als der Meniskus nicht ausgewählter Tropfen, und mit einer Tropfentrennvorrichtung (74), um den ausgewählten Tropfen vom Drucker zu einem Empfangsmedium (51) hinzuziehen.
2. Drop-on-demand Drucksystem nach Anspruch 1, dadurch gekennzeichnet, daß die elektrisch gesteuerte Betätigungsverrichtung (56 - 58) Wärme auf die Spitzen ausgewählter Düsen (59) überträgt.
3. Drop-on-demand Drucksystem nach Anspruch 2, dadurch gekennzeichnet, daß die elektrisch gesteuerte Betätigungsverrichtung (56 - 58) eine elektrothermische Vorrichtung ist.
4. Drop-on-demand Drucksystem nach Anspruch 1, dadurch gekennzeichnet, daß die Tropfentrennvorrichtung (74) ein elektrisches Feld ist, das auf elektrisch leitfähige Tinte (100) einwirkt.
5. Drop-on-demand Drucksystem nach Anspruch 1, dadurch gekennzeichnet, daß die Tropfentrennvorrichtung (74) ein magnetisches Feld ist, das auf flüssige Tinte (100) einwirkt, die magnetisch aktive Partikel enthält.
6. Drop-on-demand Drucksystem nach Anspruch 1, dadurch gekennzeichnet, daß der Druck, den die Mittel auf die Tinte (100) ausüben, ein sich zyklisch verändernder Druck ist.
7. Drop-on-demand Drucksystem nach Anspruch 6, dadurch gekennzeichnet, daß der unterschiedliche Druck auf die Tinte (100) durch eine piezoelektrische Vorrichtung erzeugt wird, an die eine veränderbare Spannung anlegbar ist.

Revendications

- 5
- 10
- 15
- 20
- 25
- 30
- 35
- 40
- 45
- 50
- 55
1. Système d'impression à gouttes à la demande comprenant une encre (100) qui est capable d'être périodiquement attirée, magnétiquement ou électriquement, et une imprimante munie d'une tête d'impression (50), la tête d'impression (50) étant munie de buses (59) et d'un moyen permettant d'appliquer une pression, qui est au moins périodiquement supérieure à la pression de l'air ambiant, à l'encre (100) contenue dans les buses (59) afin de former un ménisque, ladite tête d'impression (50) comprenant un dispositif de commande électrique (56-58) qui agit sur la surface du ménisque pour sélectionner une goutte en réduisant suffisamment la tension superficielle ou la viscosité de ladite goutte pour que le ménisque de ladite goutte sélectionnée se déplace, sous l'effet de ladite pression, vers une position différente de celle du ménisque des gouttes non sélectionnées, et un appareillage de séparation des gouttes (74) permettant d'attirer la goutte sélectionnée de l'imprimante vers un support d'enregistrement (51).
  2. Système selon la revendication 1, dans lequel ledit dispositif de commande électrique (56-58) applique de la chaleur à la pointe des buses sélectionnées (59).
  3. Système selon la revendication 2, dans lequel le dispositif de commande électrique (56-58) est un dispositif de commande électrothermique.
  4. Système selon la revendication 1, dans lequel le moyen permettant de séparer les gouttes est un champ électrique agissant sur l'encre électroconductrice (100).
  5. Système selon la revendication 1, dans lequel le moyen permettant de séparer les gouttes (74) est un champ magnétique agissant sur l'encre liquide (100) qui contient des particules magnétiquement actives.
  6. Système d'impression à gouttes à la demande selon la revendication 1, dans lequel ledit moyen permettant d'appliquer une pression à l'encre (100) est adapté pour appliquer une pression variant de manière cyclique.
  7. Système d'impression à gouttes à la demande selon la revendication 6, dans lequel lesdites variations de la pression de l'encre (100) sont produites par un dispositif piézoélectrique auquel est appliquée une tension variable.

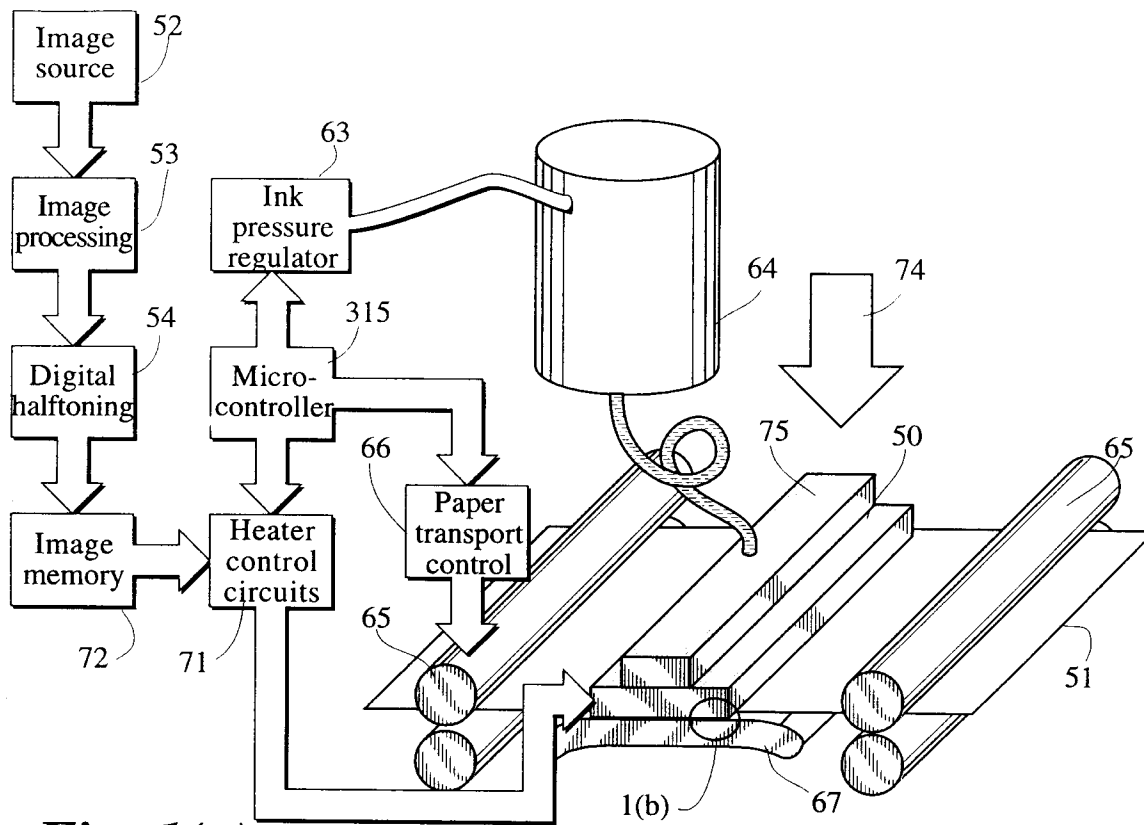


Fig. 1(a)

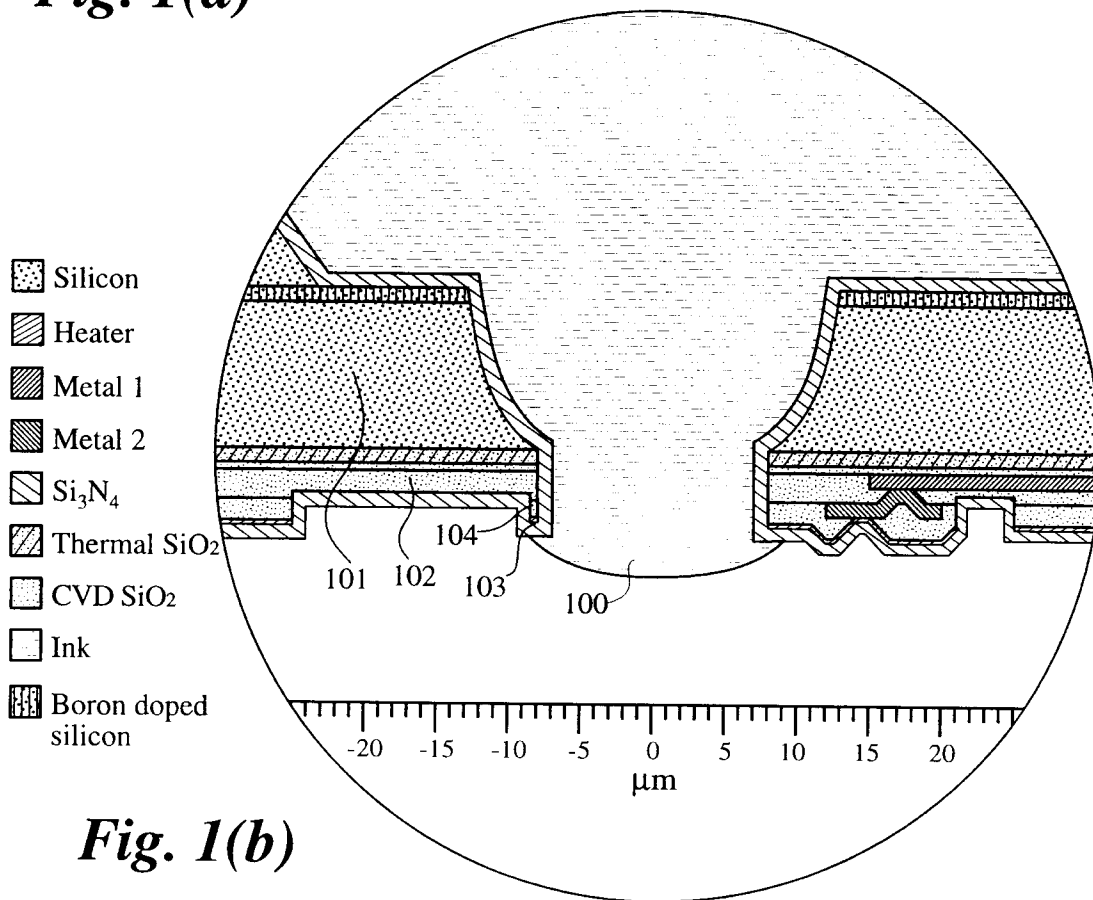
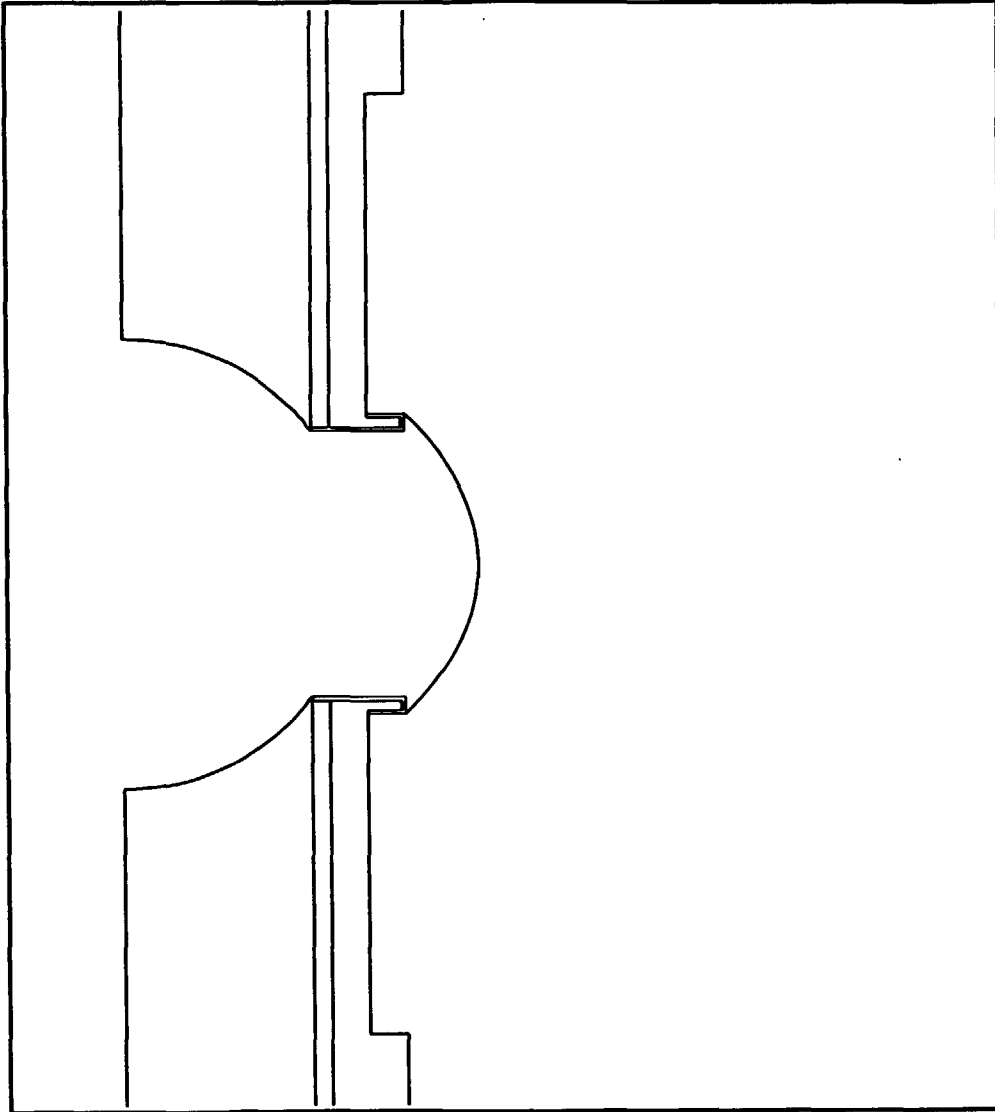
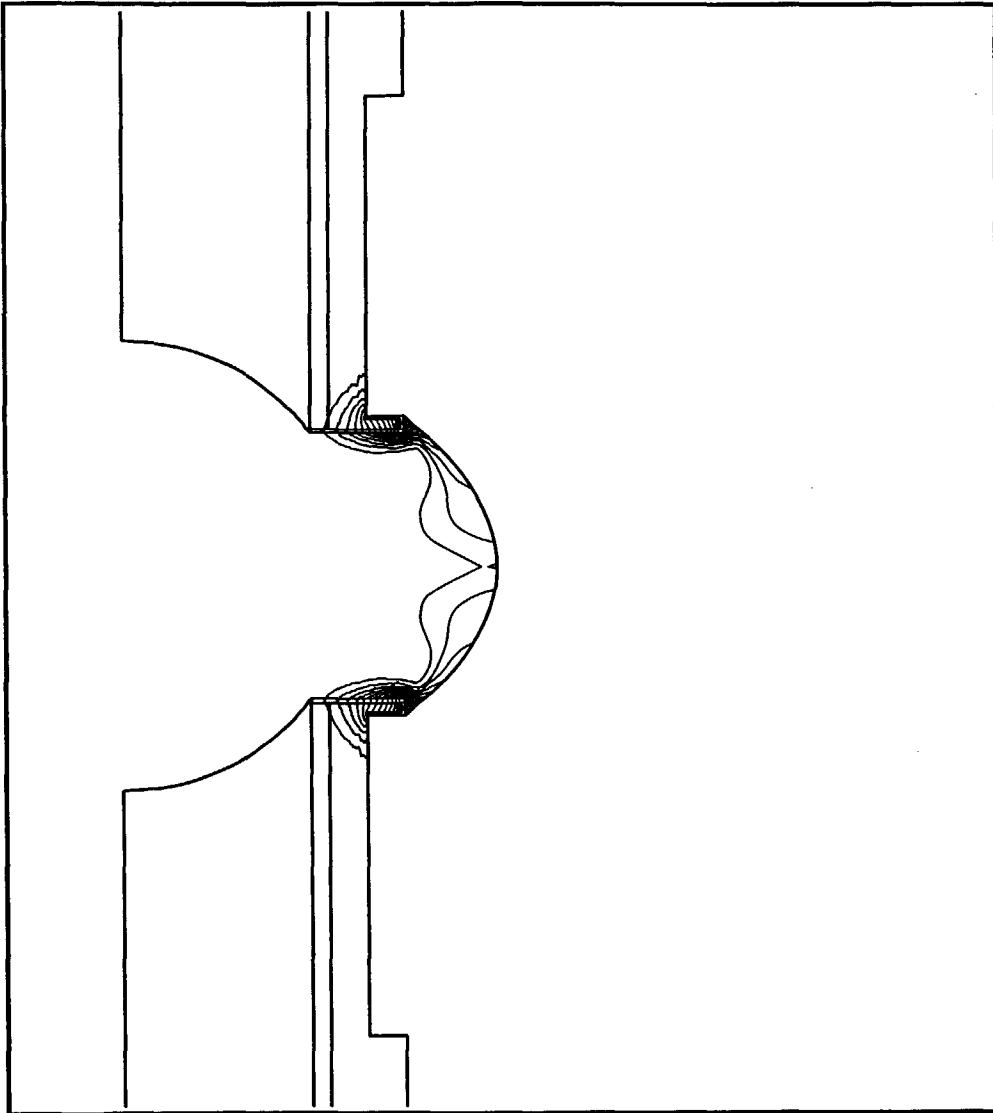


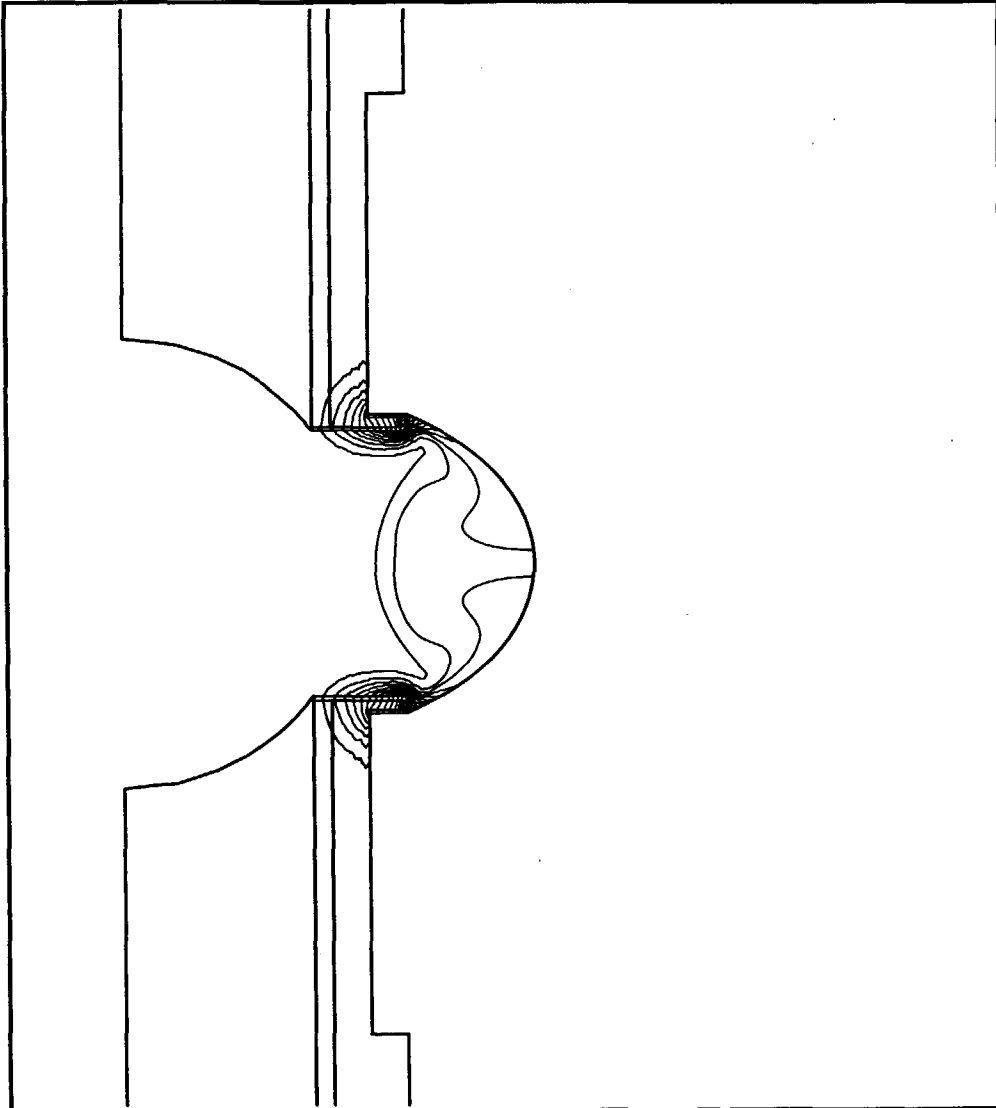
Fig. 1(b)



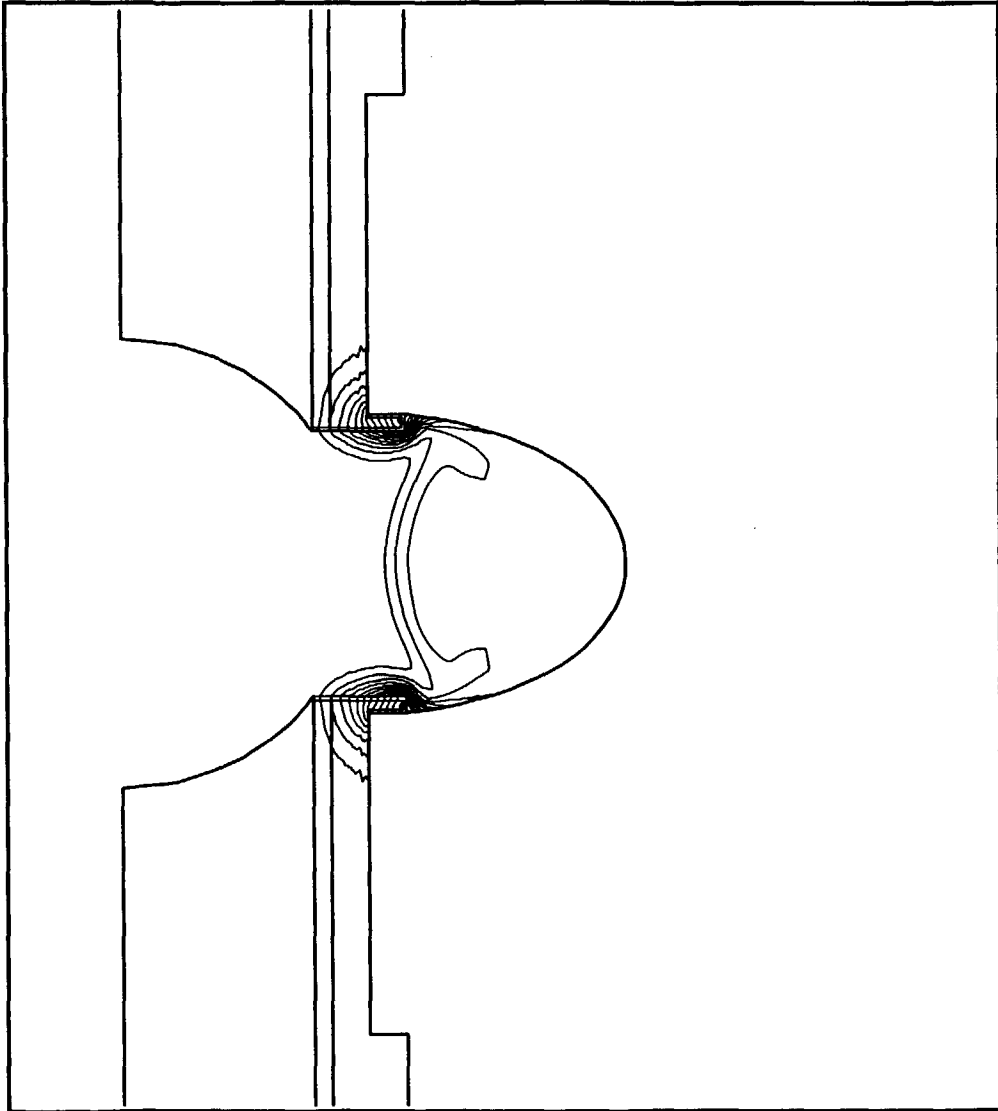
*Fig. 2(a)*



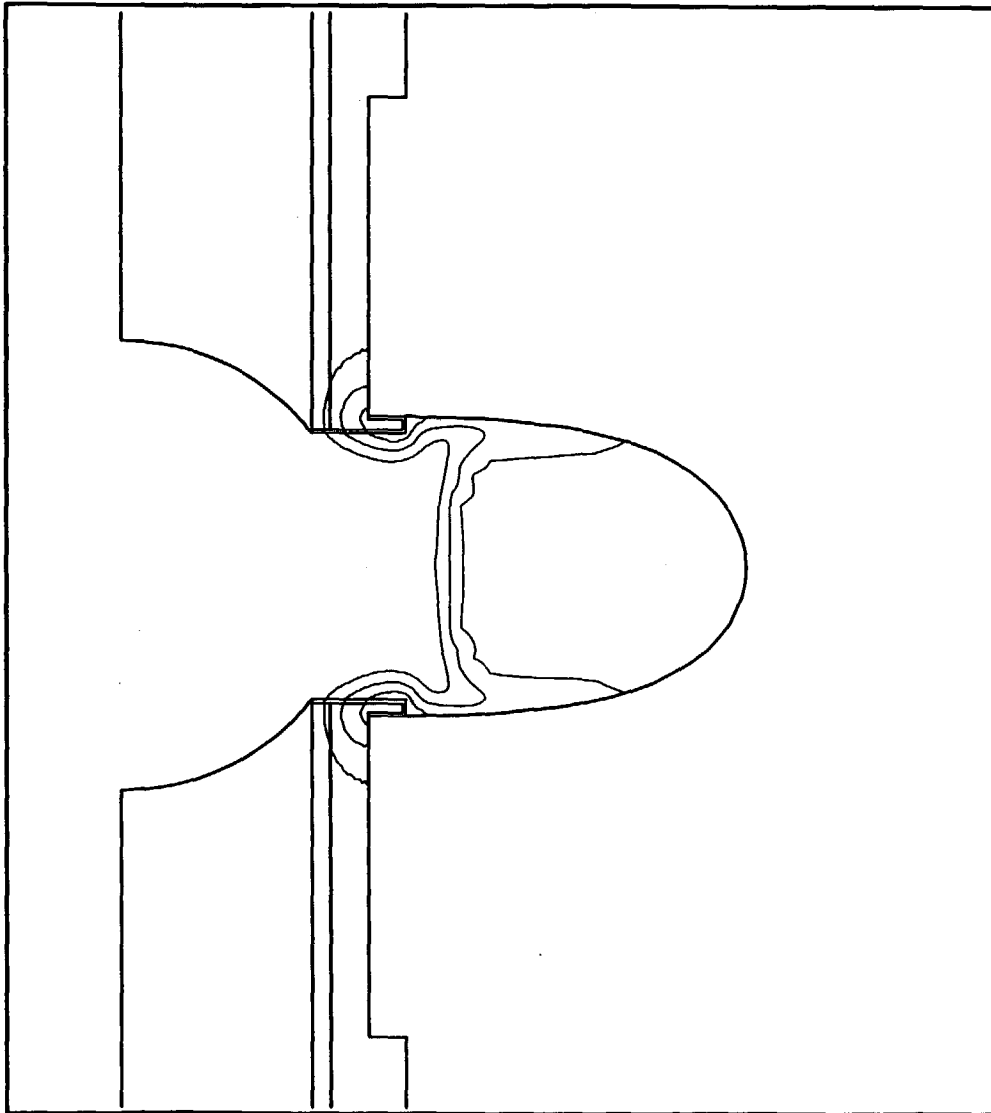
*Fig. 2(b)*



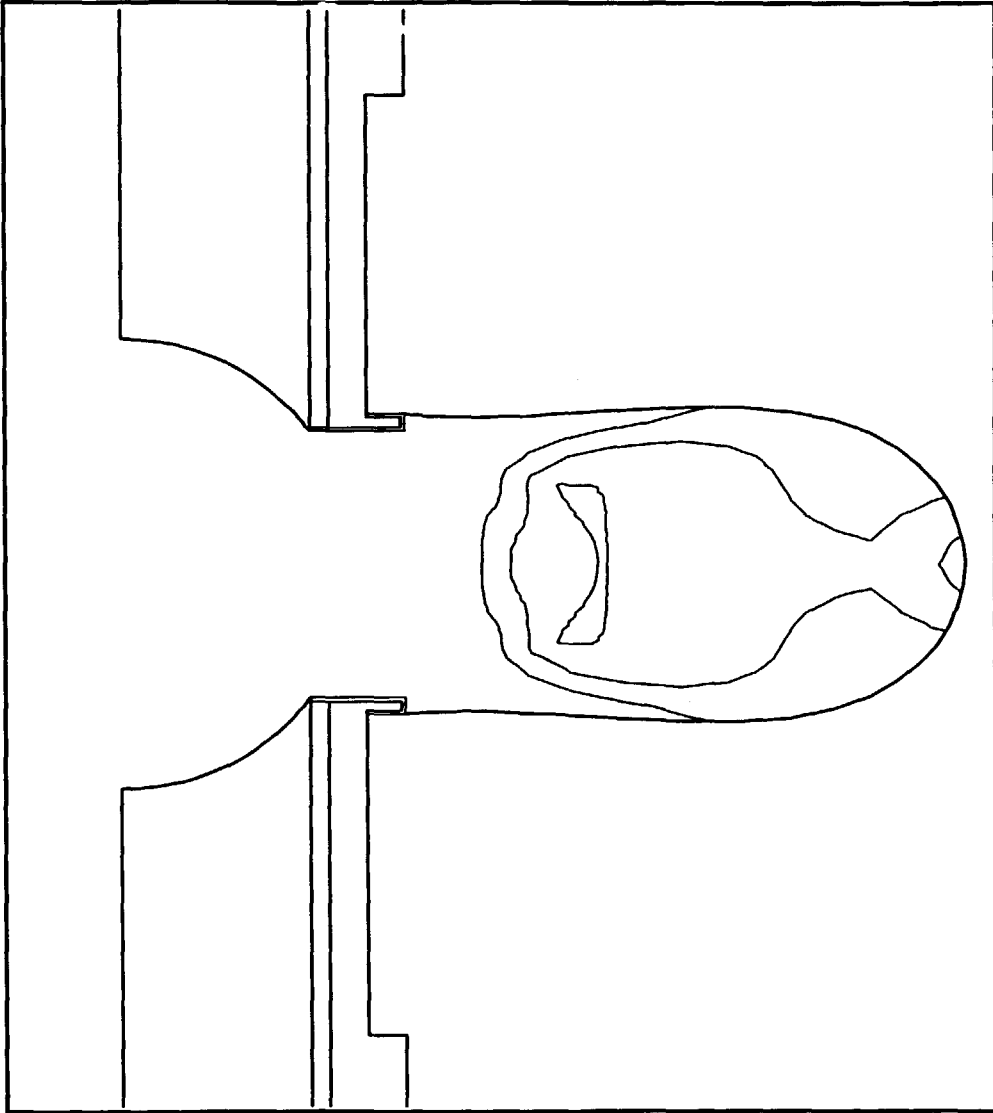
*Fig. 2(c)*



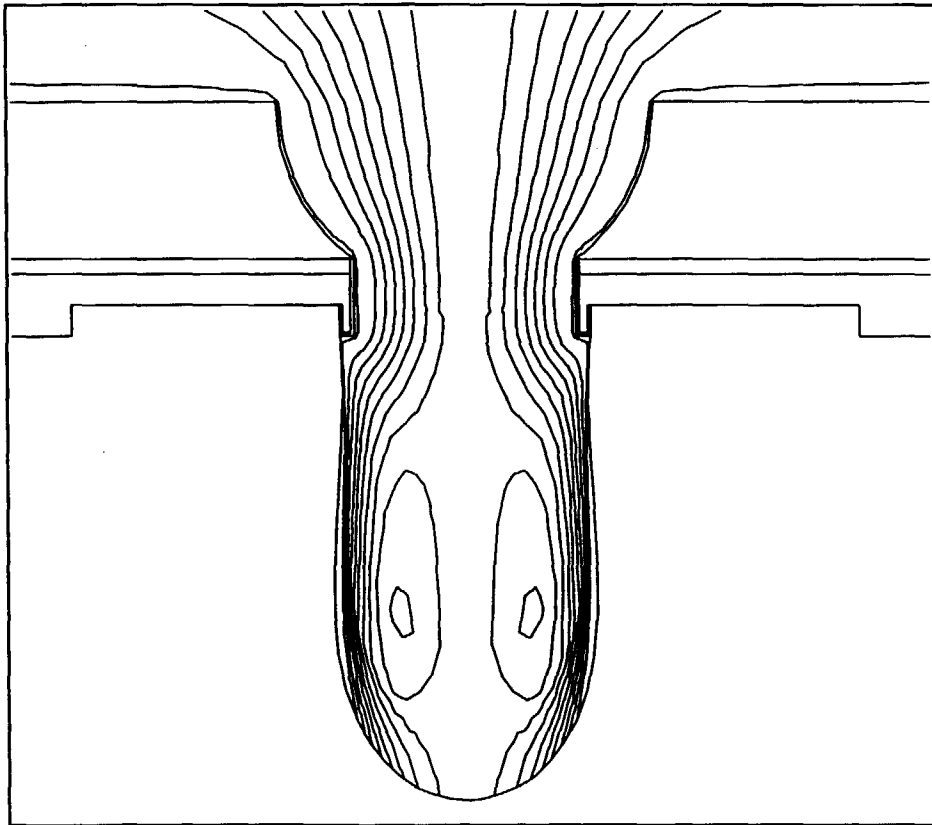
*Fig. 2(d)*



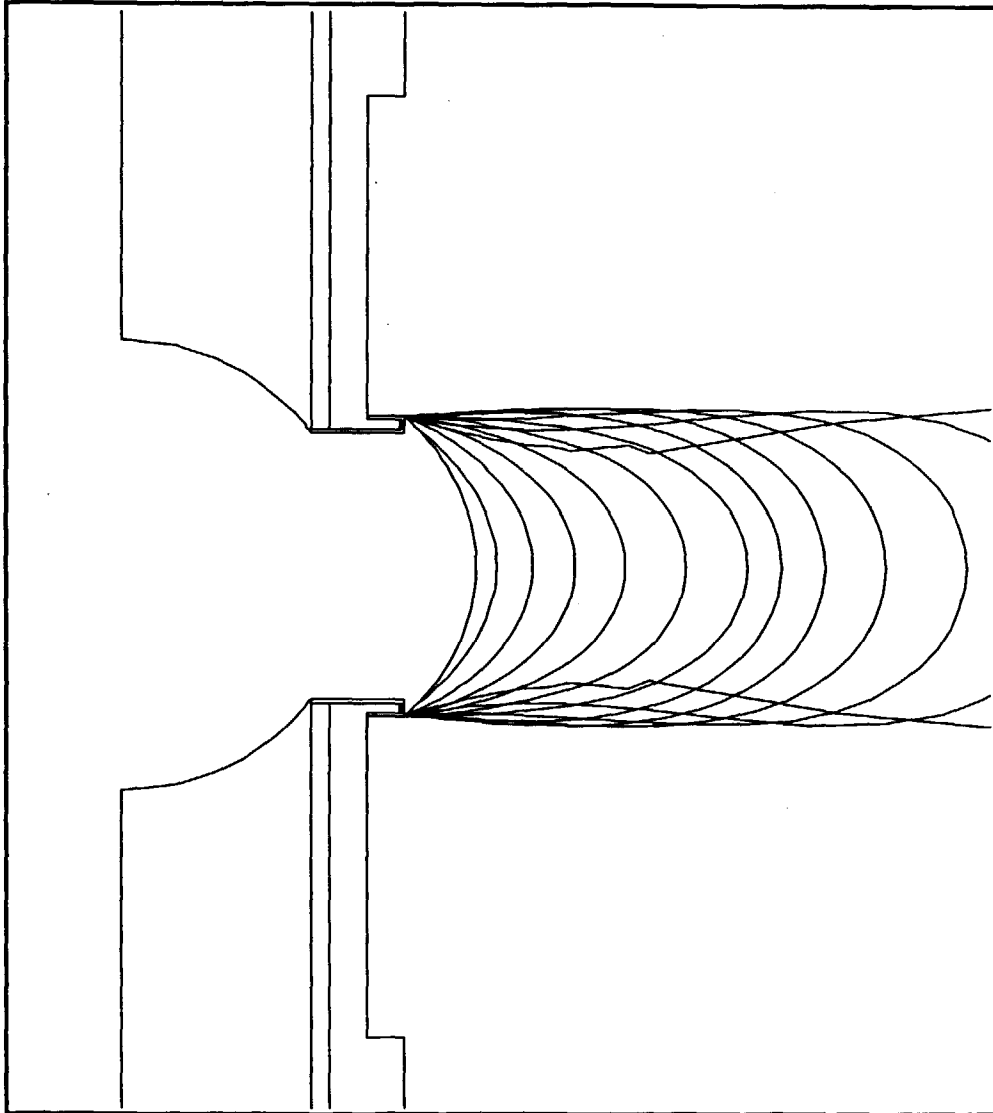
*Fig. 2(e)*



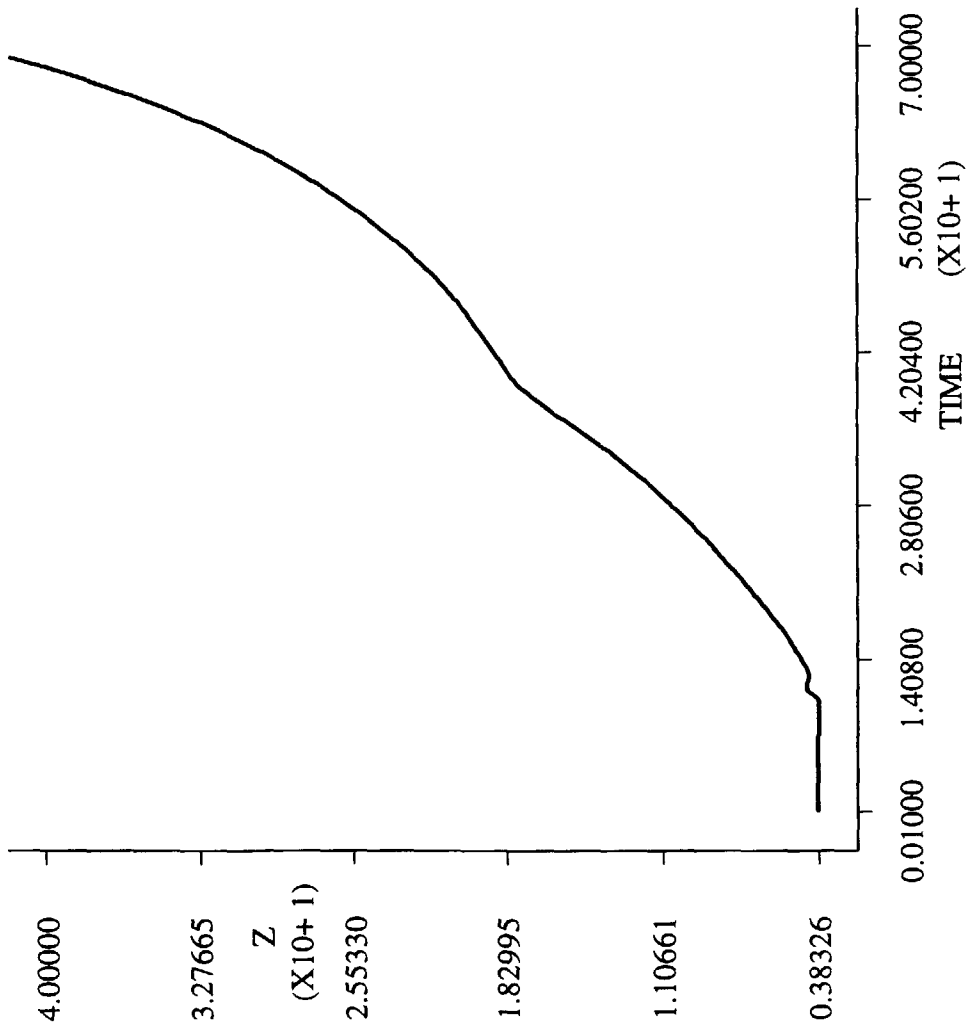
*Fig. 2(f)*



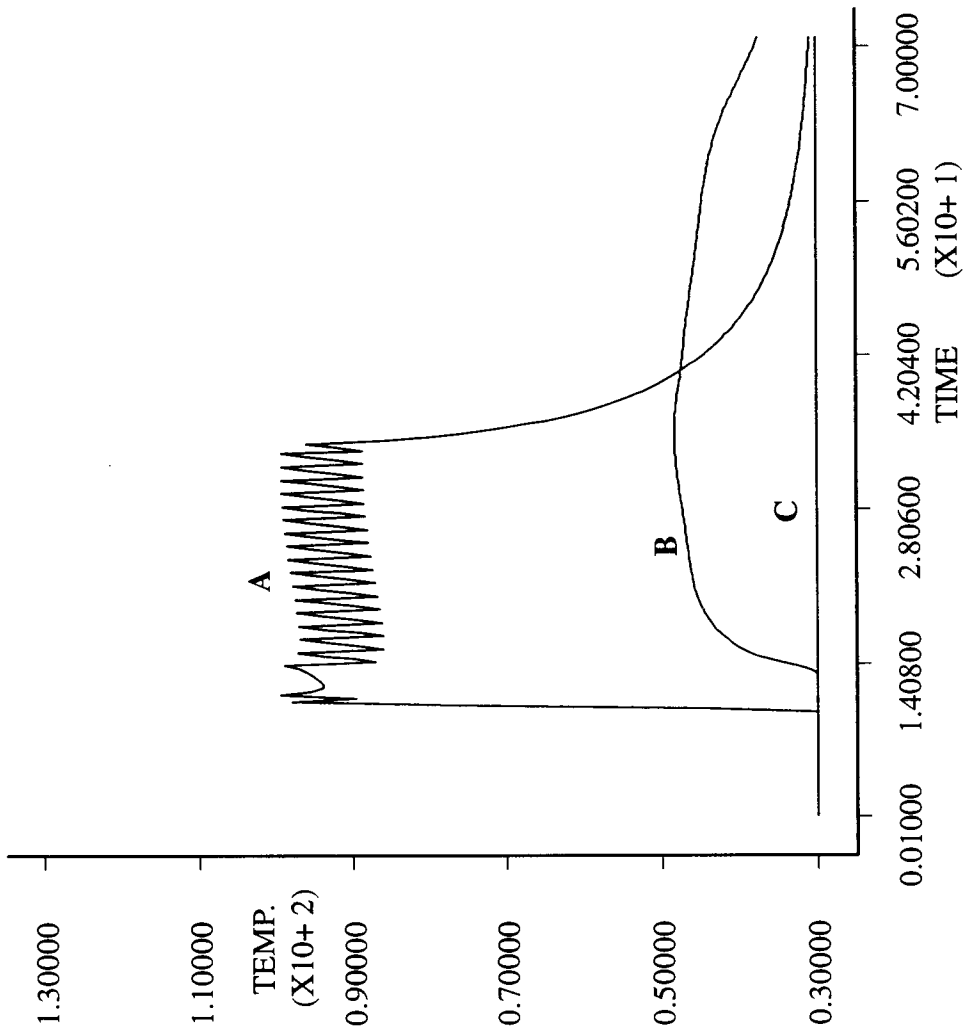
*Fig. 2(g)*



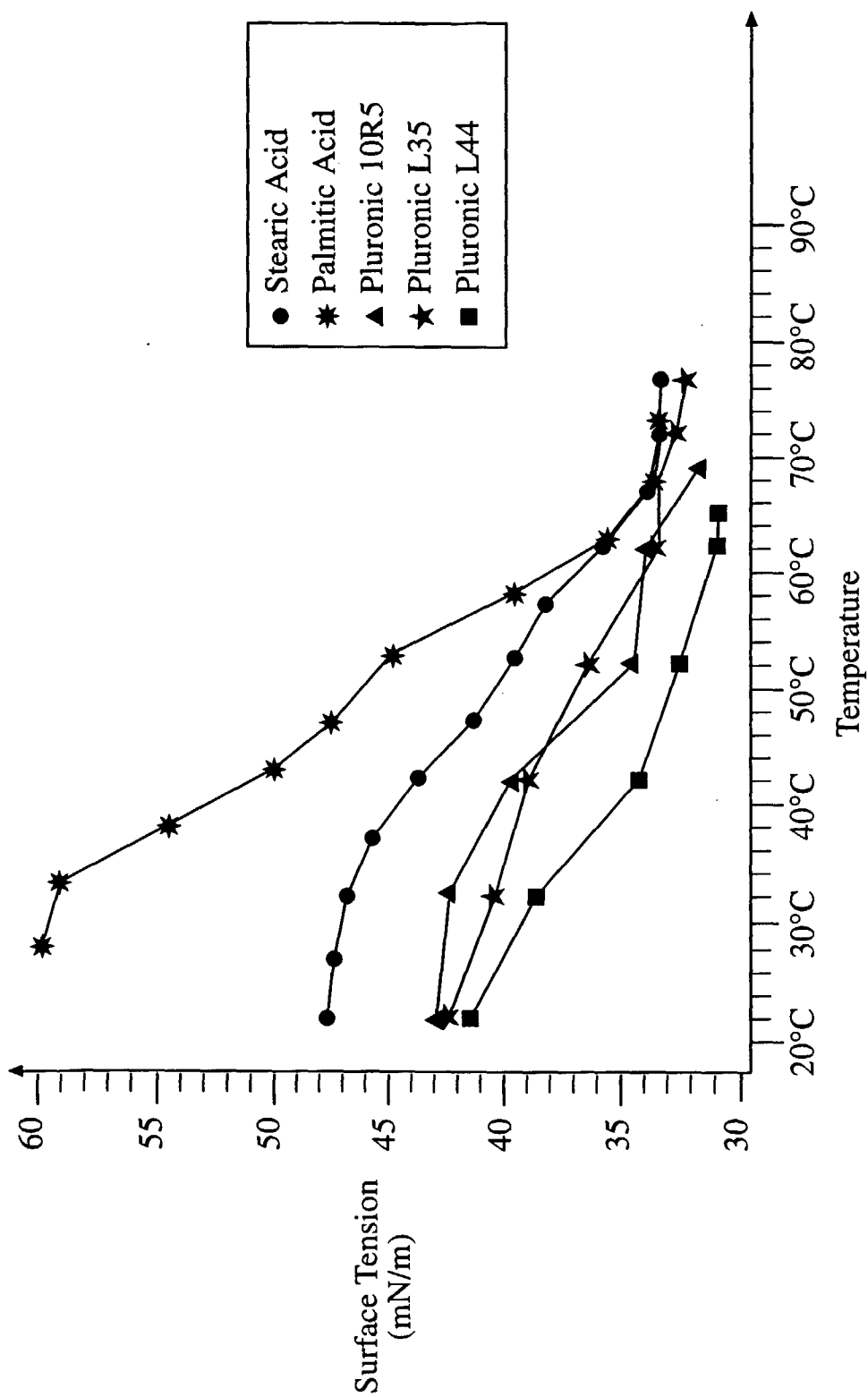
*Fig. 3(a)*



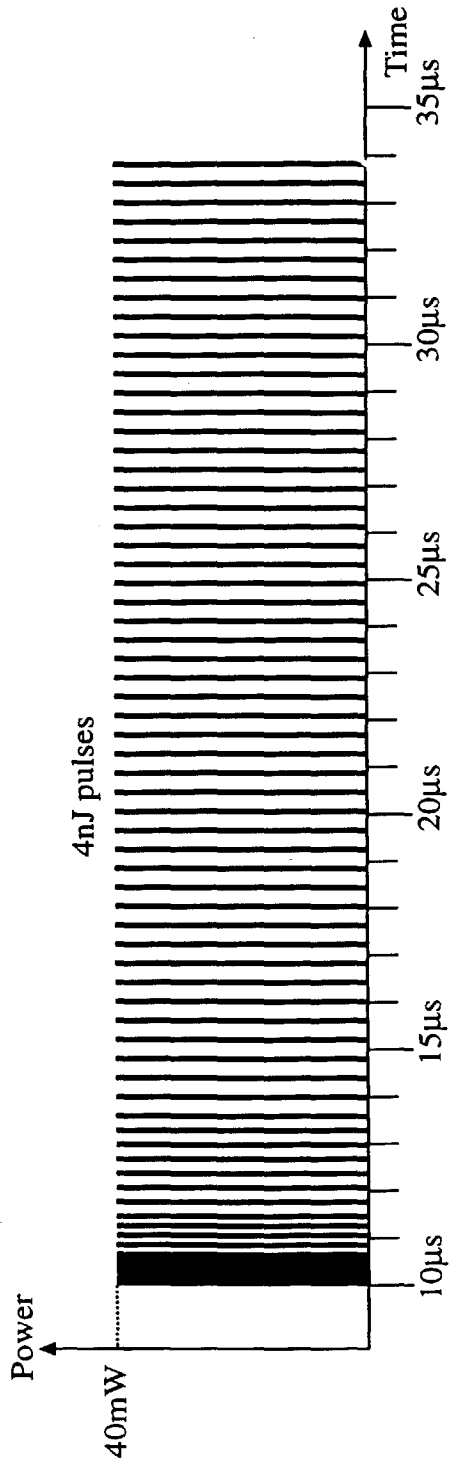
*Fig.3(b)*



*Fig. 3(c)*



*Fig. 3(d)*



*Fig. 3(e)*

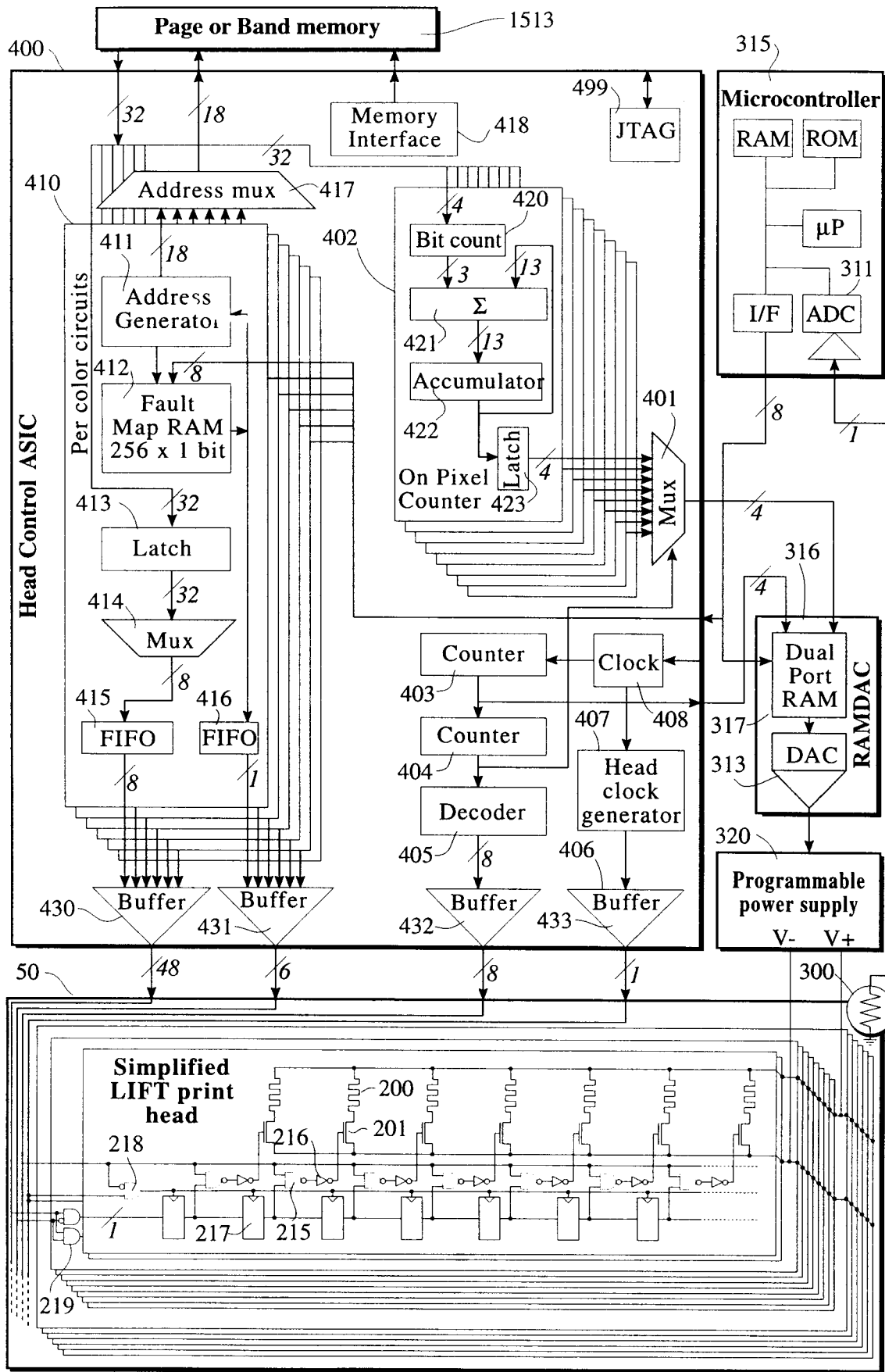
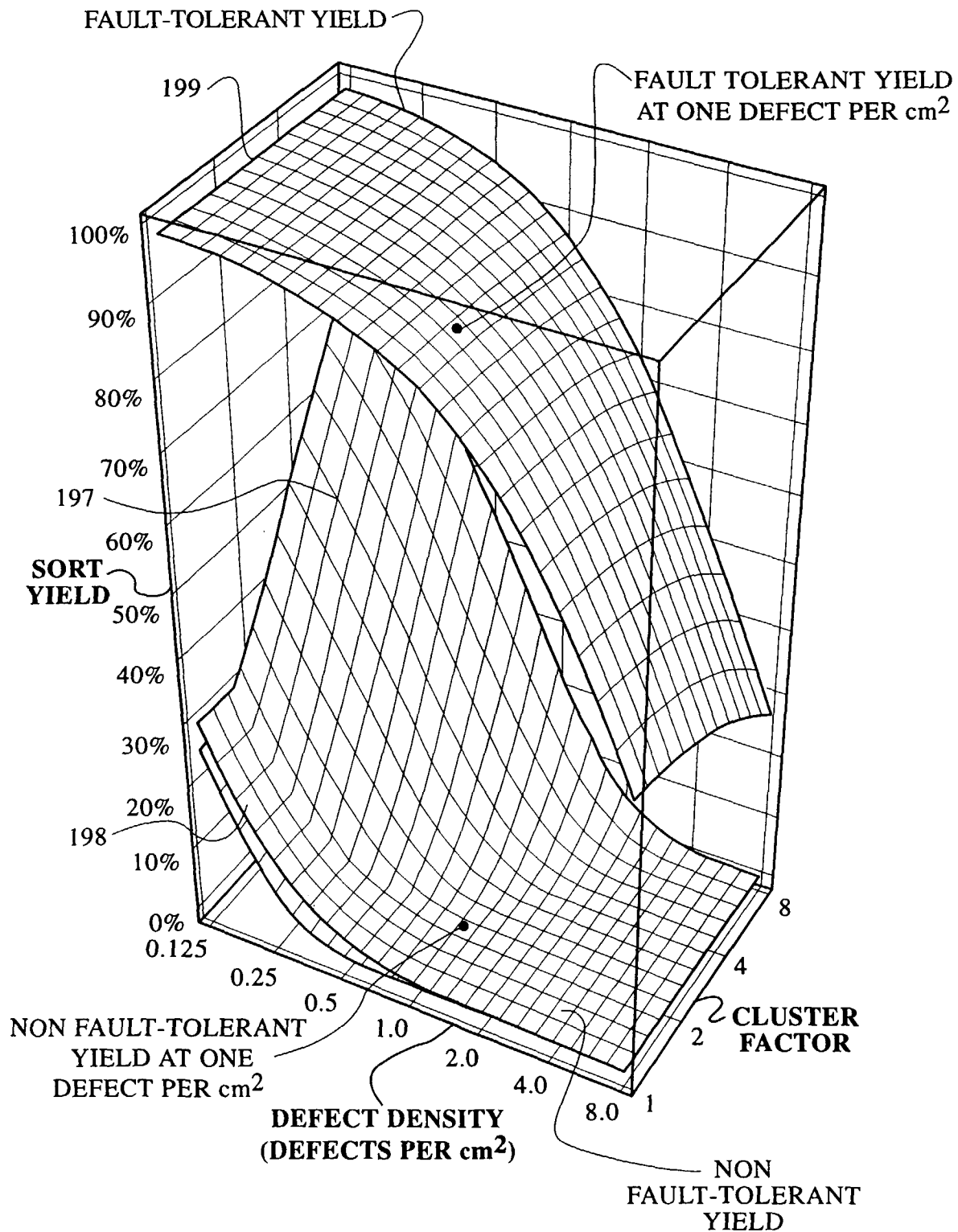
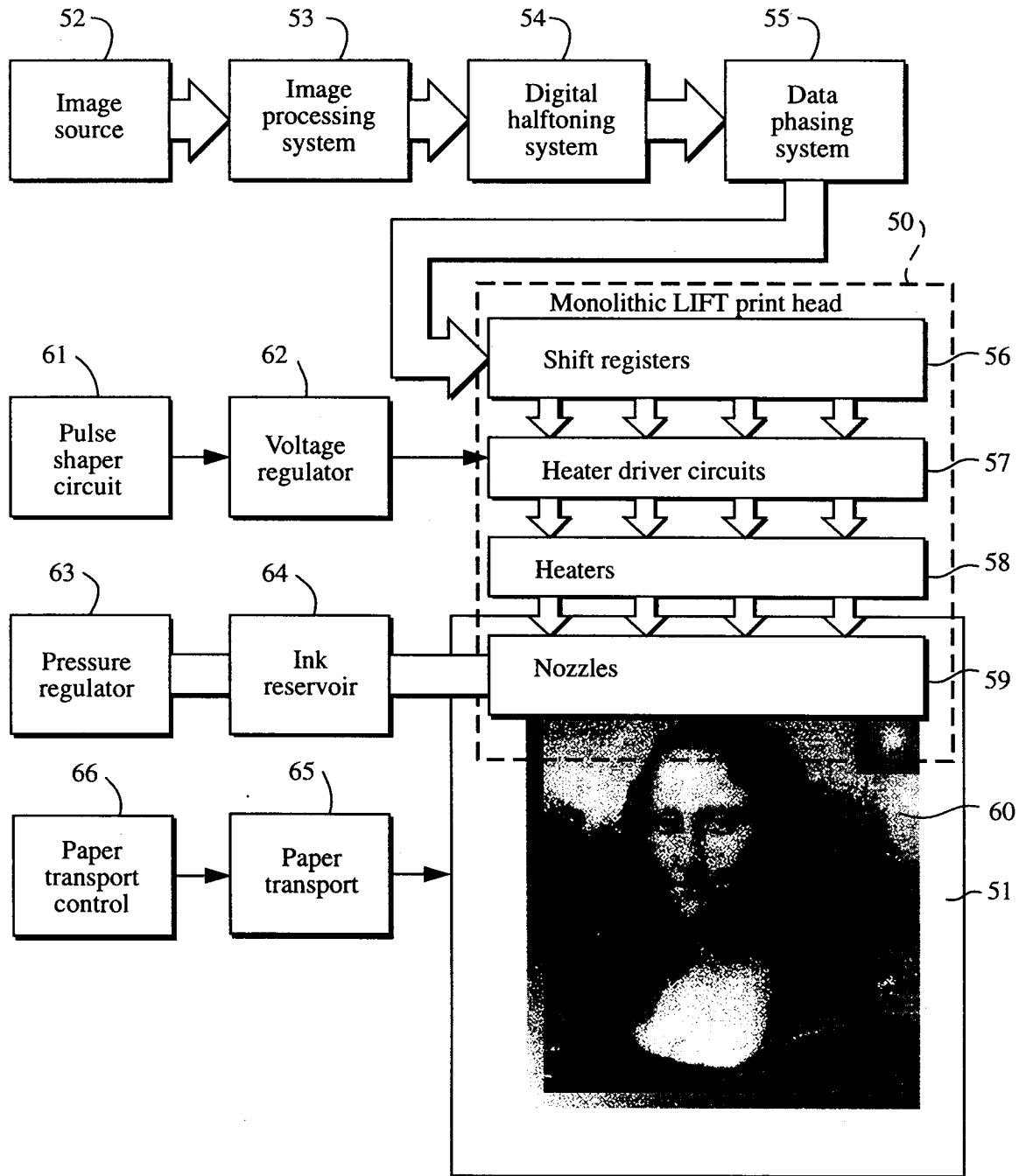


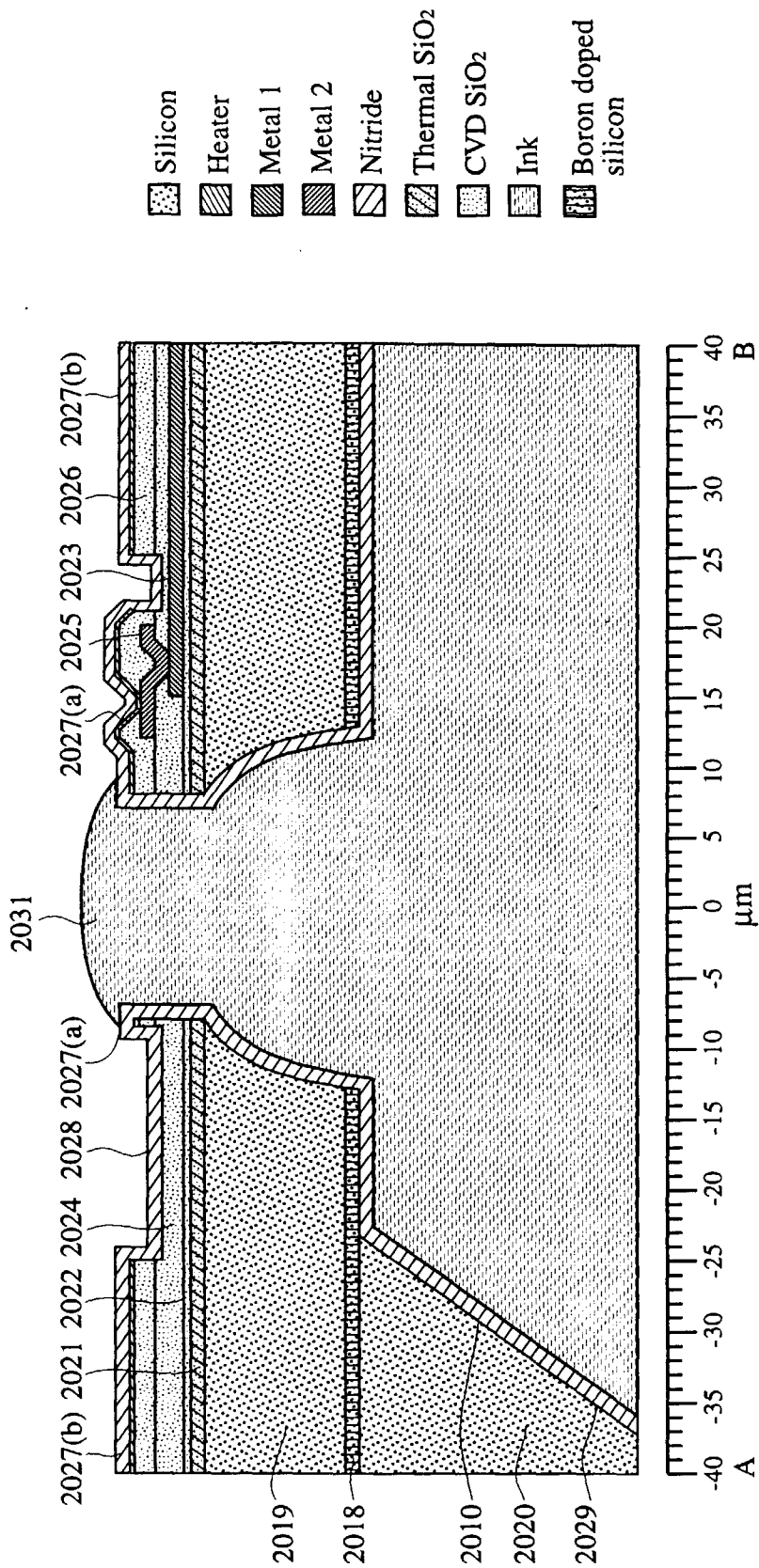
Fig. 4



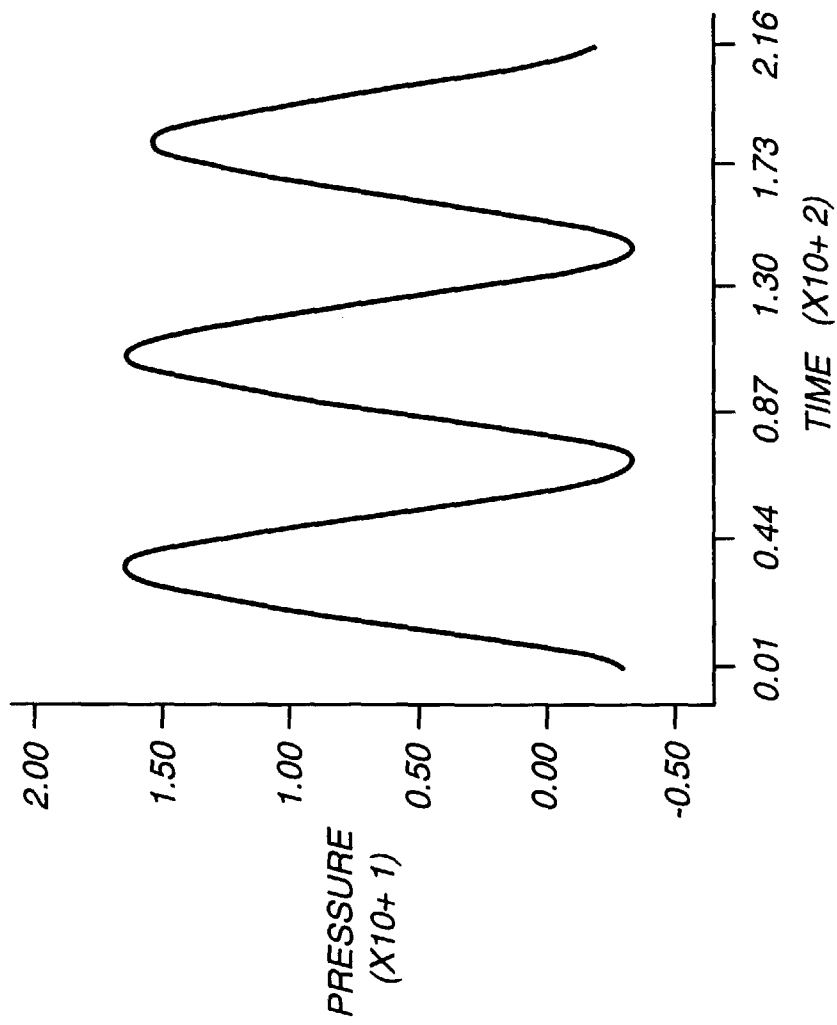
**Fig. 5**



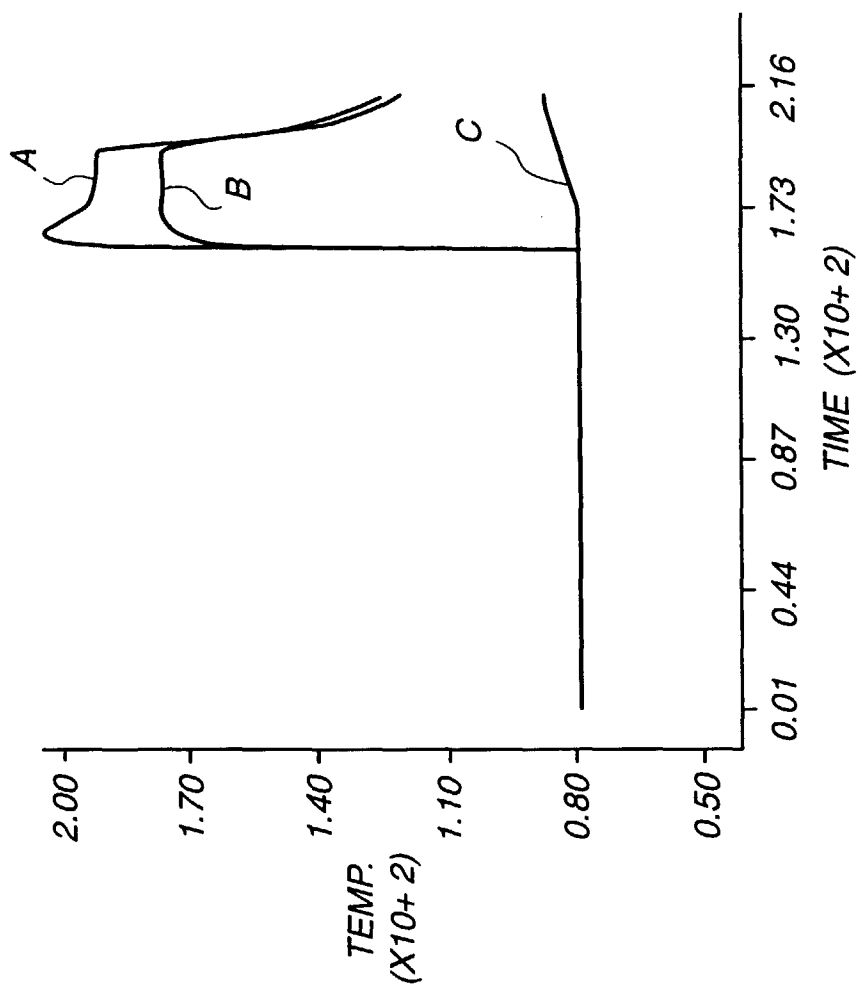
*Fig. 6(a)*



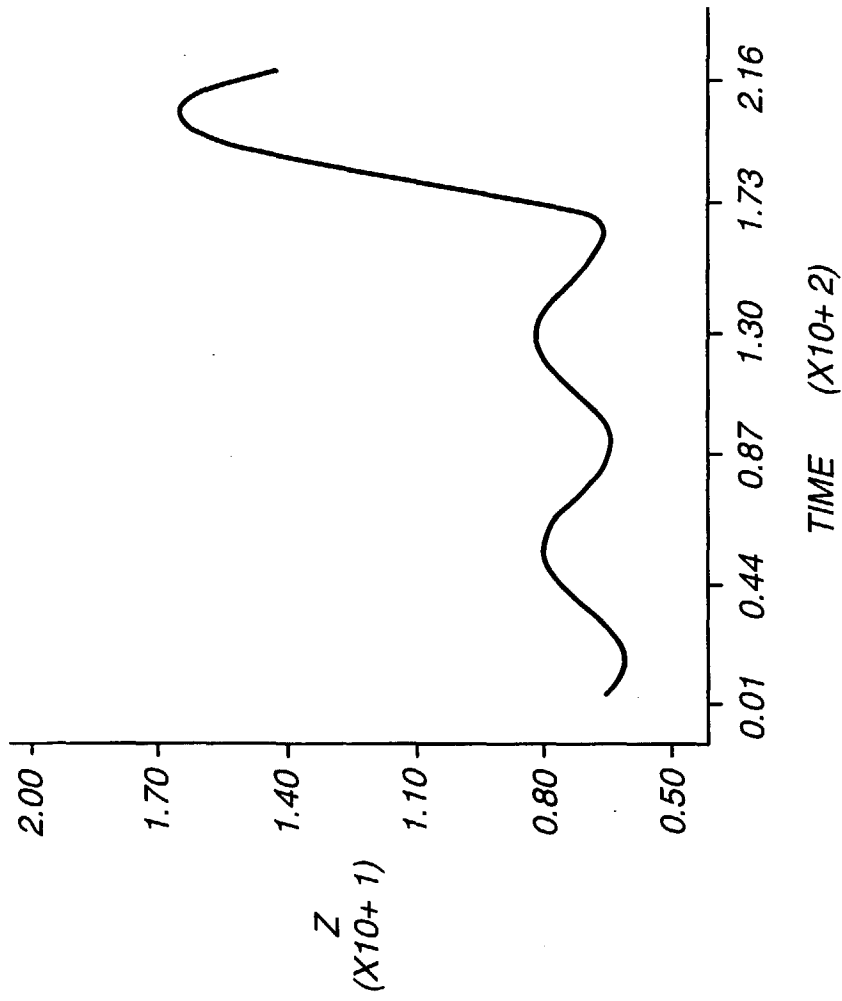
**Fig. 6(b)**



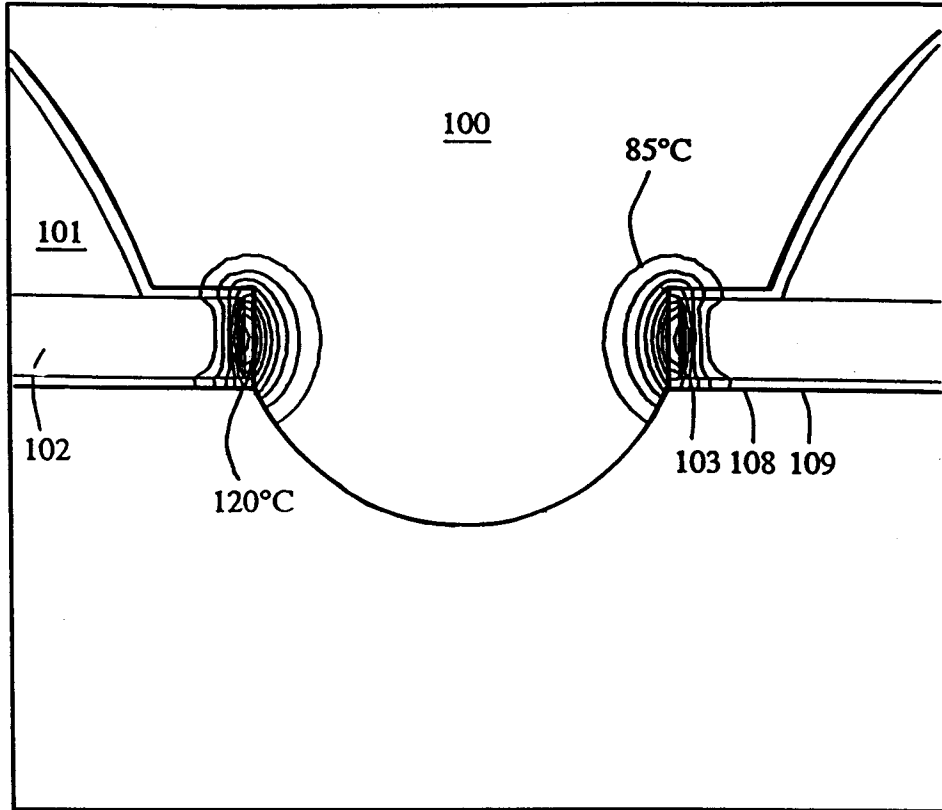
**Fig. 7**



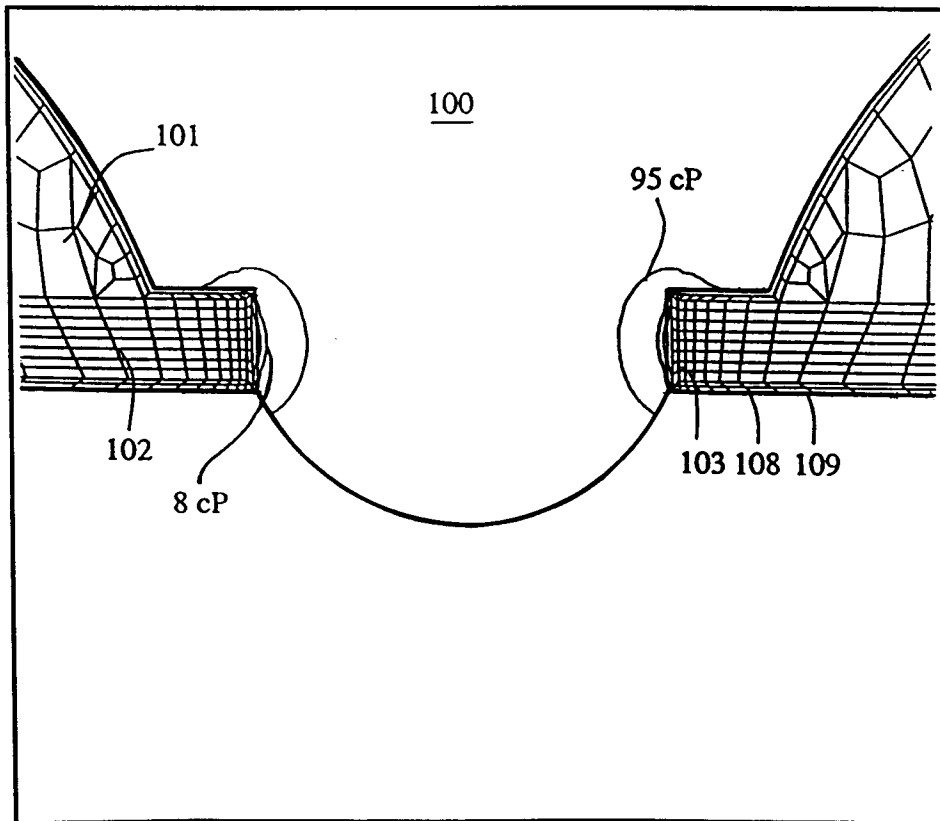
**Fig. 8**



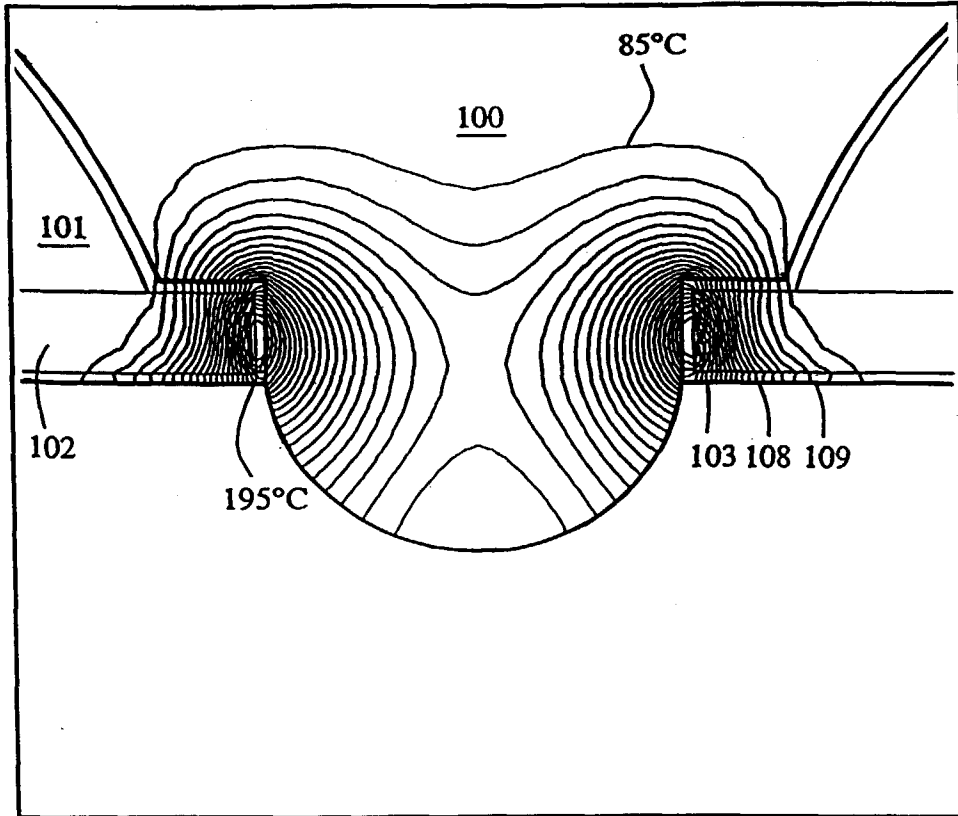
**Fig. 9**



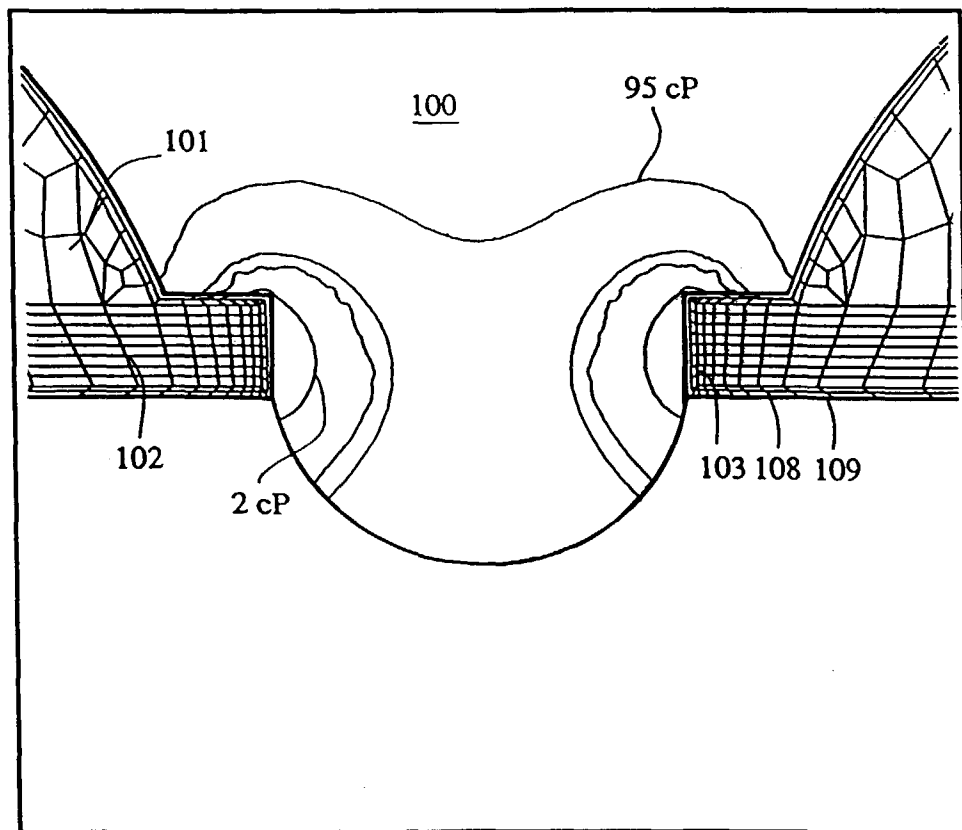
*Fig. 10(a)*



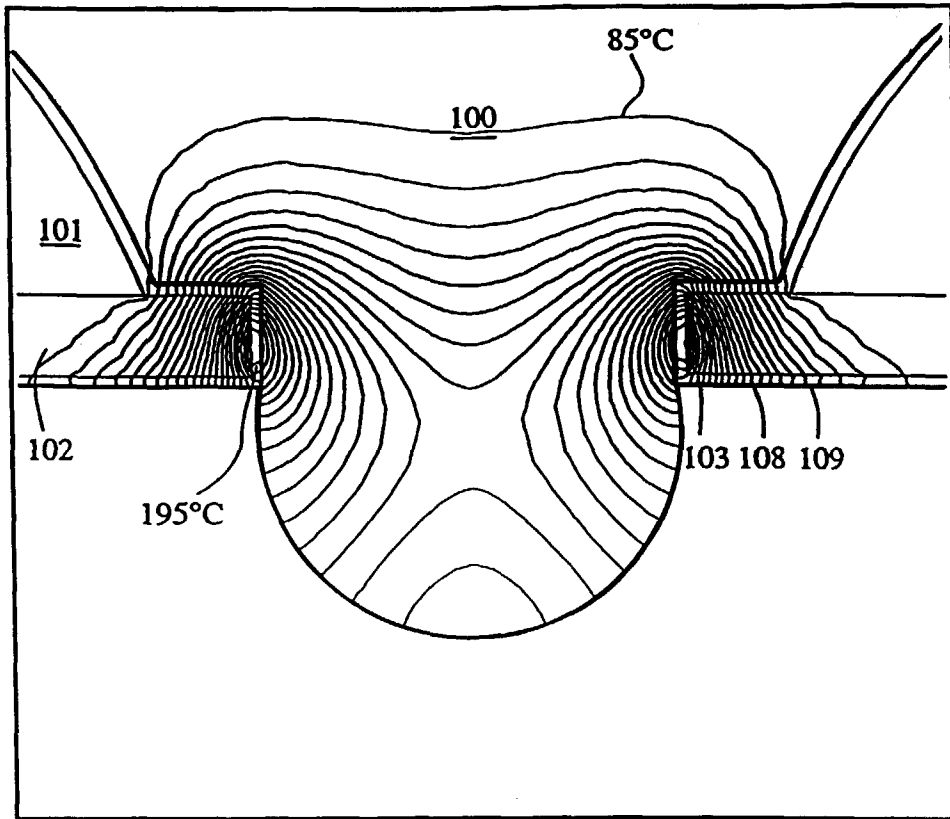
*Fig. 10(b)*



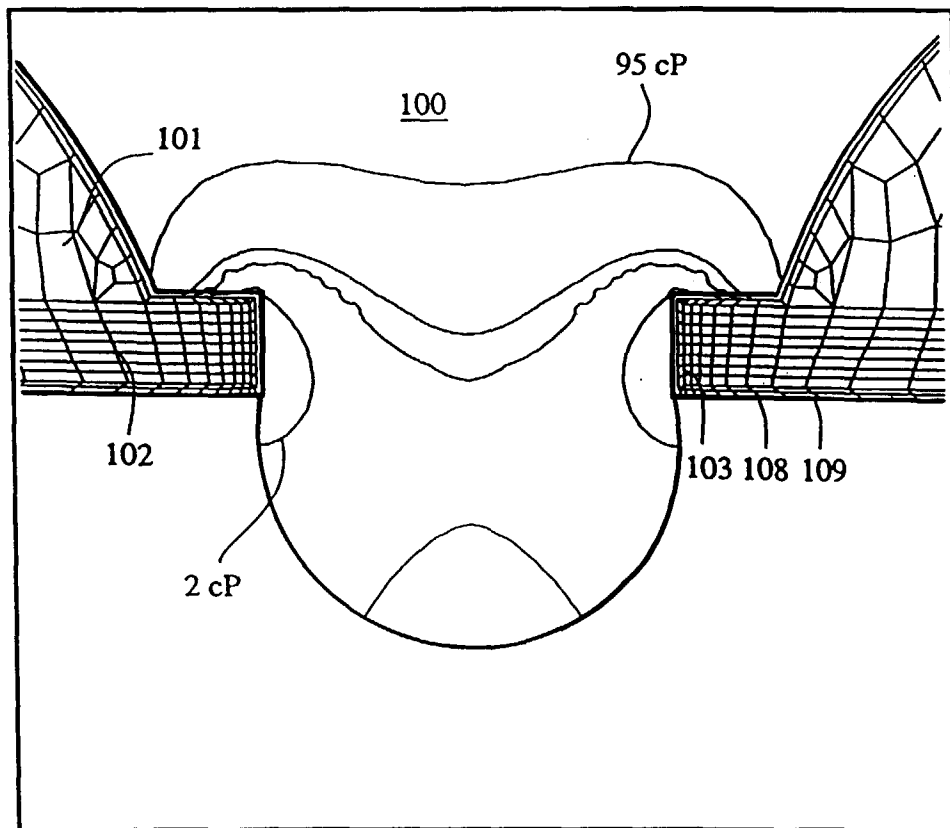
*Fig. 10(c)*



*Fig. 10(d)*

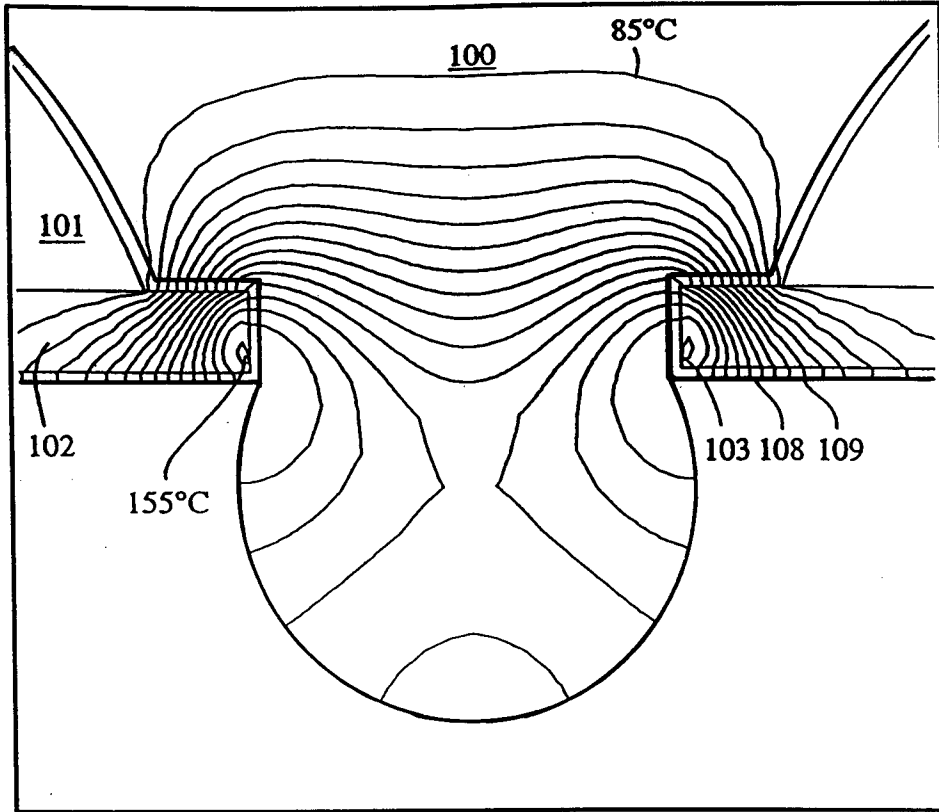


*Fig. 10(e)*

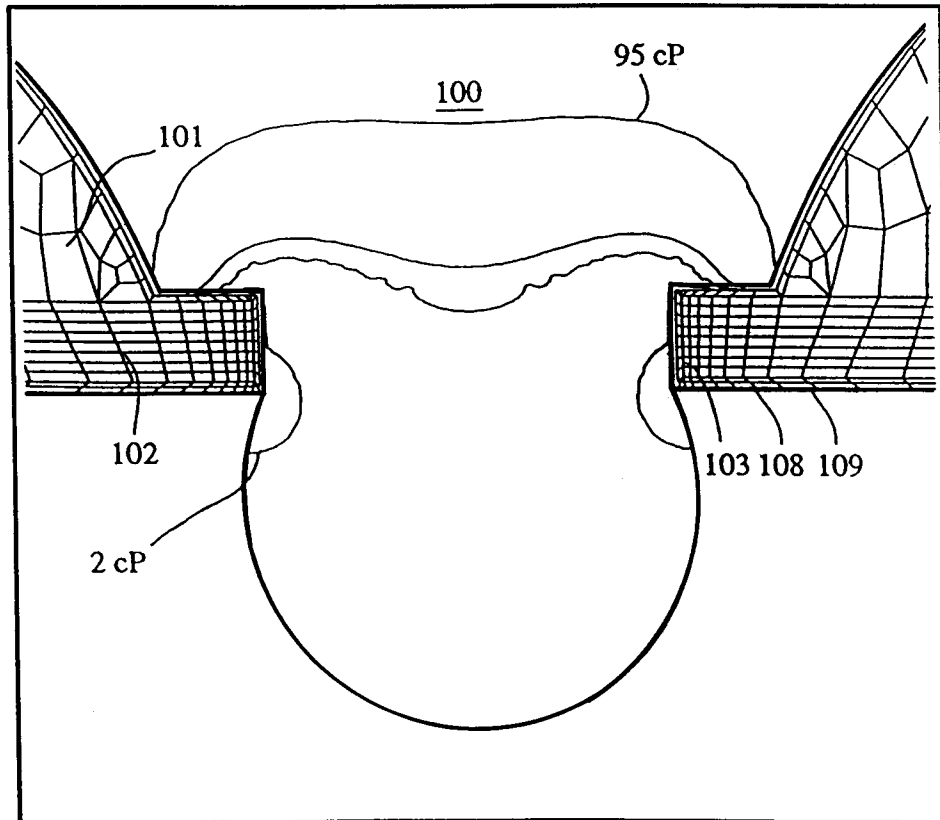


*Fig. 10(f)*

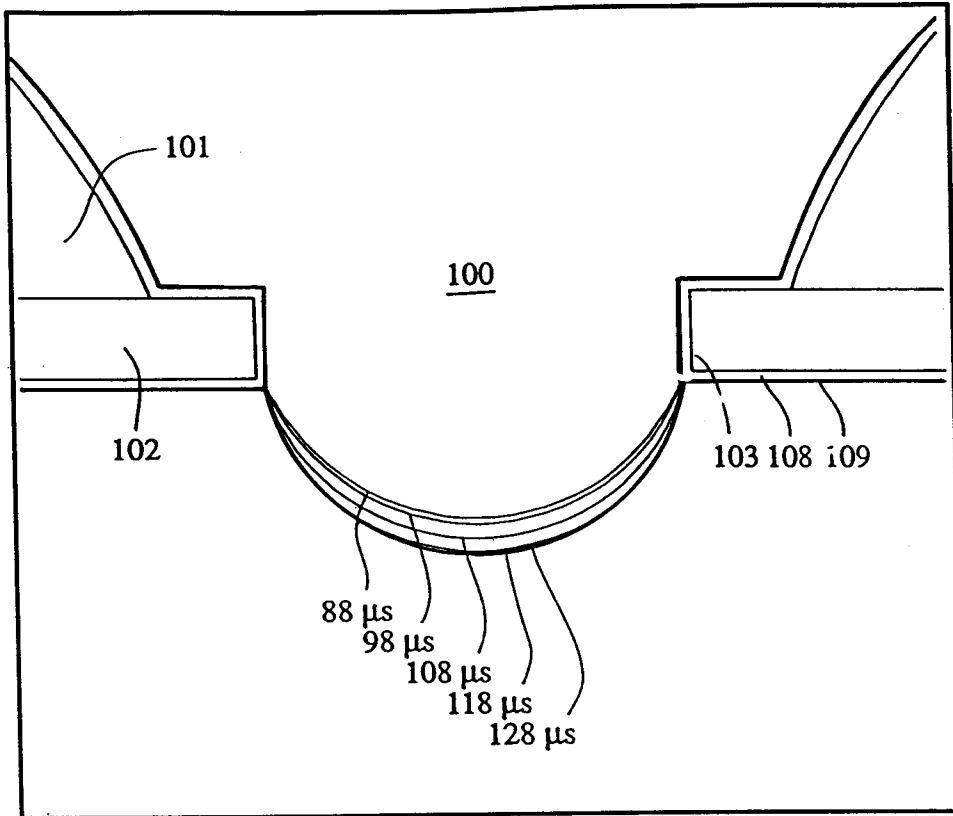




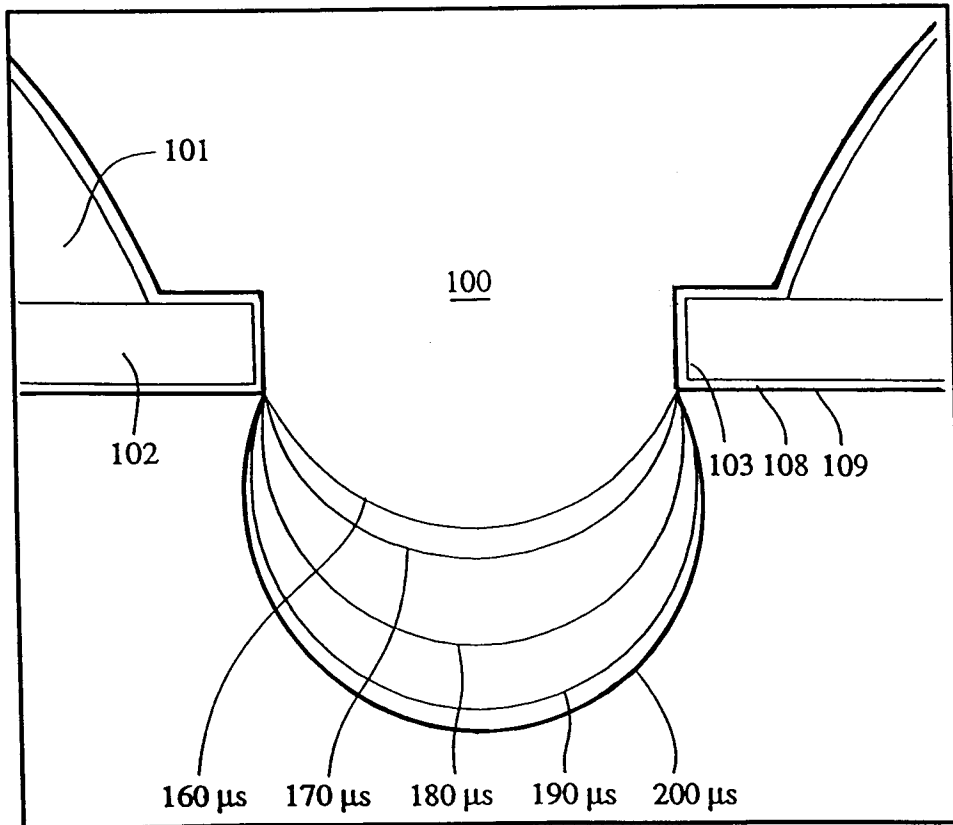
*Fig. 10(i)*



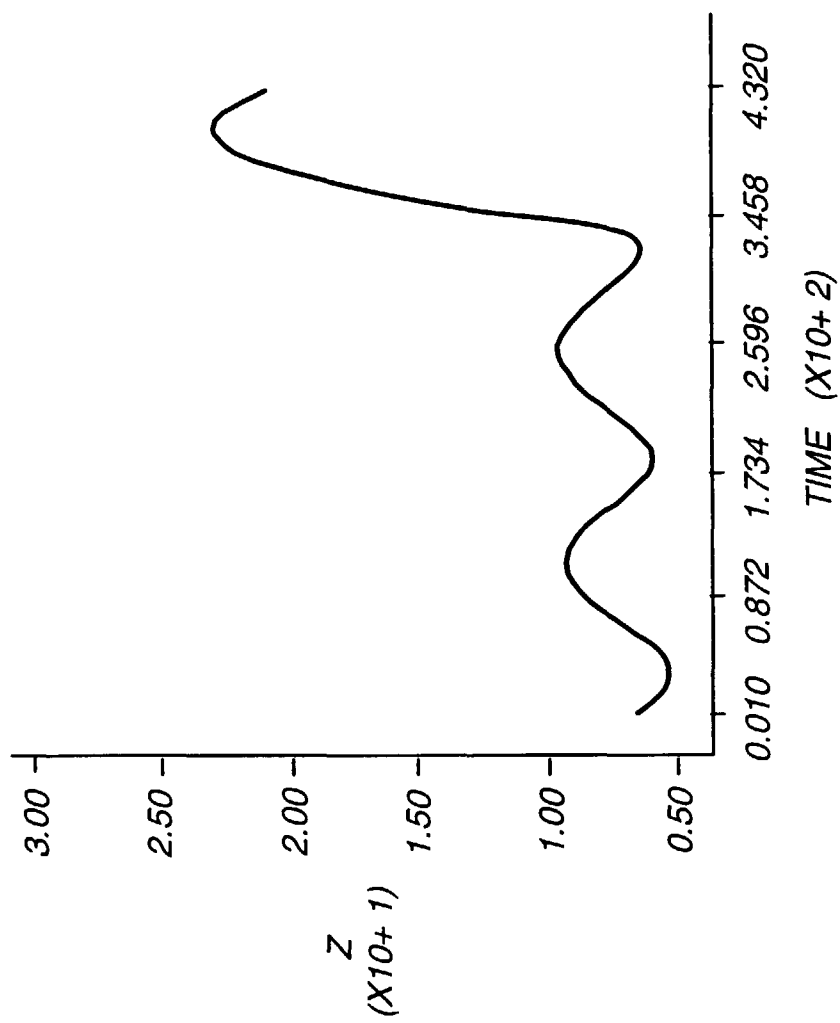
*Fig. 10(j)*



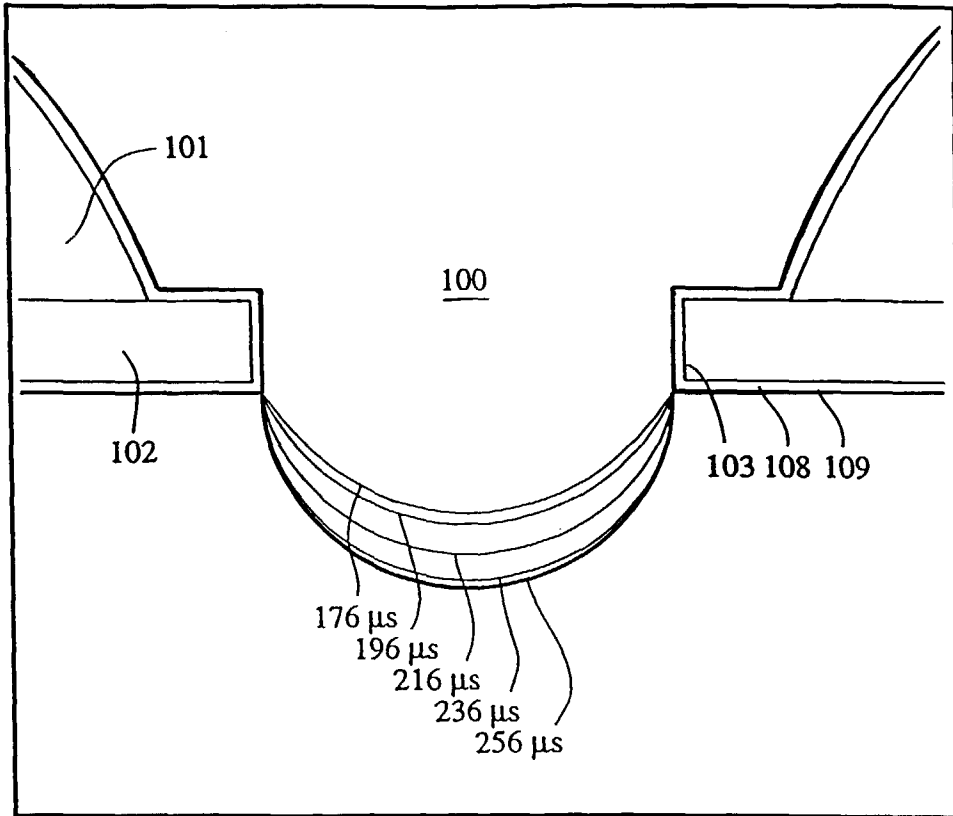
*Fig. 11*



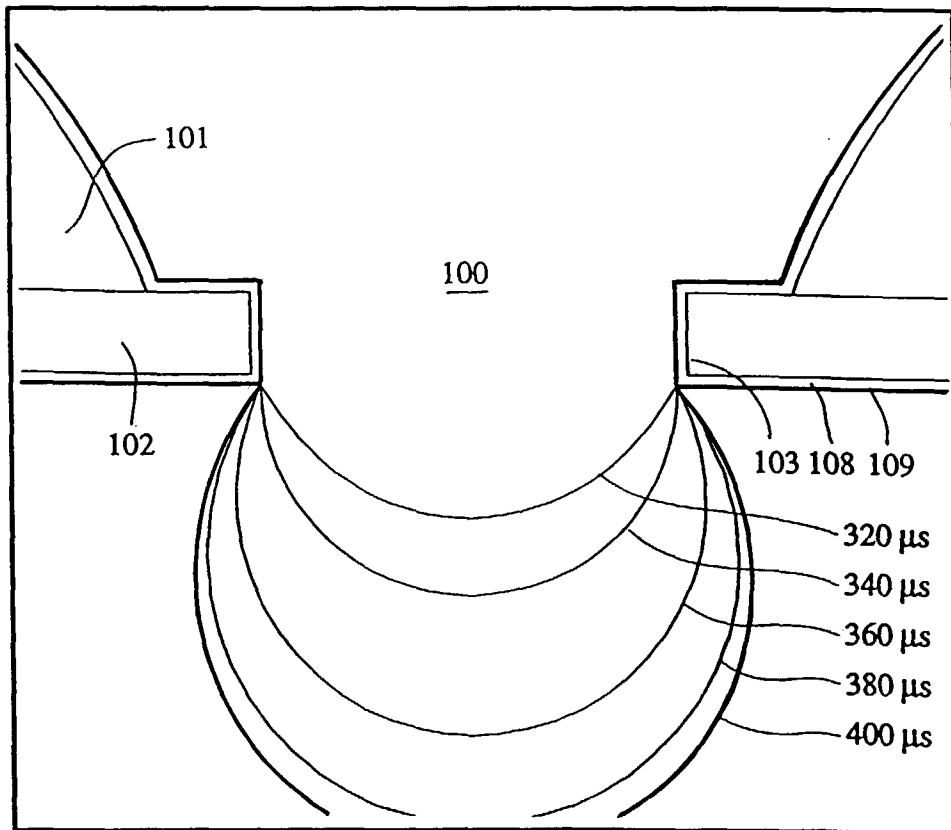
*Fig. 12*



**Fig. 13**



**Fig. 14**



**Fig. 15**