

(19)



(11)

EP 4 184 728 B1

(12)

EUROPEAN PATENT SPECIFICATION

(45) Date of publication and mention of the grant of the patent:
25.06.2025 Bulletin 2025/26

(51) International Patent Classification (IPC):
H01R 24/52 ^(2011.01) **H01R 24/50** ^(2011.01)
H01R 24/54 ^(2011.01) **H01R 103/00** ^(2006.01)

(21) Application number: **21208997.3**

(52) Cooperative Patent Classification (CPC):
H01R 24/50; H01R 24/52; H01R 24/542;
H01R 2103/00

(22) Date of filing: **18.11.2021**

(54) RF CONNECTOR FOR CONTACTING A PRINTED CIRCUIT BOARD

HF-VERBINDER ZUM KONTAKTIEREN EINER GEDRUCKTEN LEITERPLATTE

CONNECTEUR RF POUR CONTACTER UNE CARTE DE CIRCUIT IMPRIMÉ

(84) Designated Contracting States:
**AL AT BE BG CY CZ DE DK EE ES FI FR GB GR
HR HU IS IT LT LU LV MC MK MT NL NO PL PT RO
RS SE SI SK SM TR**

(72) Inventors:
• **Leipold, Markus**
84424 Isen (DE)
• **Huber, Florian**
81735 Munich (DE)

(43) Date of publication of application:
24.05.2023 Bulletin 2023/21

(74) Representative: **Novagraaf Group**
Chemin de l'Echo 3
1213 Onex / Geneva (CH)

(73) Proprietor: **Rohde & Schwarz GmbH & Co. KG**
81671 München (DE)

(56) References cited:
GB-A- 2 512 822 **JP-A- 2011 134 720**
US-B1- 6 824 392

EP 4 184 728 B1

Note: Within nine months of the publication of the mention of the grant of the European patent in the European Patent Bulletin, any person may give notice to the European Patent Office of opposition to that patent, in accordance with the Implementing Regulations. Notice of opposition shall not be deemed to have been filed until the opposition fee has been paid. (Art. 99(1) European Patent Convention).

Description

TECHNICAL FIELD

[0001] The present invention relates to an RF connector for contacting a printed circuit board.

BACKGROUND

[0002] Radio frequency (RF) connectors can be mounted to printed circuit boards (PCB) of electronic devices, e.g. measurement instruments, in order to contact the respective apparatus with coaxial cables or the like. On the one hand, it is beneficial if the installation process of these connectors is kept as quick and simple as possible without the need for complex and expensive mounting tools. On the other hand, the mechanical and electrical contact should be stable and durable. Amongst others, the RF connection should be reasonably free of mechanical stress.

[0003] Providing such an RF connector with a small sized coaxial contact terminal can simplify the soldering process as soldering larger metal components usually requires higher temperatures and mechanical loads during soldering. Small terminals on the other hand imply small connectors, which may have lower mechanical stability. Connectors with large outer conductors may also be fastened by clamping, which however may be electrically less stable. Moreover, the installation of common connectors usually relies on the usage of centering tools, which usually have to be removed afterwards making the installation process laborious.

[0004] Prior art document EP 3 432 424 A1 describes an RF connector system, wherein a mechanical connection is made by two wing shaped surface mount sections of a housing having a plurality of surface mount studs adapted to match which pads on a PCB. The electrical connection to the PCB is made by an inner conductor and at least one matching block electrically connected to the housing and providing a matched impedance at the PCB, which has a strip line with a ground plane.

[0005] WO 2020/006195 A1 describes an enhanced electrical grounding of hybrid feed-through connectors.

[0006] US 6 824 392 B1 describes an RCA connector that is capable of being inserted into a circuit board directly.

[0007] JP 2011 134720 A describes electronic equipment with a connector structure capable of easily exchanging an external connector and retaining sufficient waterproofness and airtightness.

[0008] GB 2 512 822 A describes a two-part connector module for connecting an RF coaxial cable to a circuit board.

SUMMARY

[0009] Against this background, there is a need to find solutions for contacting PCBs with RF connectors that

provide a better trade-off between mechanical and electrical stability and installation effort.

[0010] To this end, the present invention provides an RF connector having the features of the independent claim.

[0011] According to an aspect of the invention, an RF connector for contacting a printed circuit board (PCB) comprises an RF socket configured to be mounted to the PCB, the RF socket providing a coaxial terminal with a first diameter, the first diameter being an outer diameter of the coaxial terminal; a port flange configured to be plugged on the RF socket and comprising a through-hole serving as a plug-in port with a second diameter for receiving another RF connector to be contacted to the RF socket, the second diameter being an inner diameter corresponding to the through-hole that is larger than the first diameter; and a centering nut configured to be disposed between the RF socket and the port flange for centering the port flange with respect to the RF socket, wherein the centering nut has an inner diameter corresponding to the first diameter of the RF socket and an outer diameter corresponding to the second diameter of the port flange.

[0012] Thus, one of the idea of the present invention is to attach a port flange of larger diameter to a small base connector of smaller diameter and thereby enlarge the effective contact diameter of the setup and thus its rigidity against mechanical stress, e.g. shear forces. The RF properties of the arrangement may be determined by the RF socket only and may remain unaffected by the port flange, which may serve exclusively as a mechanical support for the arrangement in order to be able to couple connectors of larger diameter to the PCB. Alignment of the setup is then ensured by arranging the centering nut between the RF socket and the port flange, where it may stay permanently. To this end, the internal diameter of the nut corresponds to the external diameter of the base body, while the external diameter of the nut corresponds to the diameter of the port flange (the fit between the components may leave some level of play in order to facilitate installation). The setup of the invention is thus particularly simple to install and yet offers improved stability against mechanical and electrical influences.

[0013] Further embodiments of the present invention are subject of the subordinate claims and of the following description, referring to the drawings.

[0014] According to an embodiment of the invention, the centering nut may be configured with an inner thread to be screwed upon the RF socket.

[0015] The installation process may thus be kept as straightforward as possible. In one example, installation of the setup may proceed as follows:

- the port flange may be loosely pre-assembled to the RF socket, e.g. by plugging it onto the RF socket without final fixation,
- the centering nut may then be screwed onto an external thread of the RF socket with a defined

torque for permanent retention, e.g. by reaching through the plug-in port of the port flange with a suitable assembly tool (the centering nut may have been positioned on the RF socket already before the port flange is plugged onto it, or, alternatively, the centering nut may be introduced only subsequently through the plug-in port of the port flange),

- the now centered port flange may be fixed tight, e.g. by screwing it to the RF socket,
- optionally, the port may additionally be fixed to a device housing, e.g. also by screws.

[0016] According to an embodiment of the invention, the centering nut may be configured with at least one assembly portion adapted to be engaged by an assembly tool.

[0017] For example, the centering nut may be provided with holes, grooves and/or recesses or the like, which may be engaged by suitable assembly tools, e.g. by reaching through the plug-in port of the port flange.

[0018] According to an embodiment of the invention, the centering nut may be formed from a metal material.

[0019] In principle any material with adequate strength and durability may be suitable for the present purpose, in particular electrically conducting materials.

[0020] According to an embodiment of the invention, the centering nut may comprise at least one of steel and copper-beryllium.

[0021] Beryllium copper combines high strength with excellent metalworking, forming and machining properties. The centering nut may thus be formed with materials that retain their shape even under repeated stress and strain.

[0022] According to an embodiment of the invention, the port flange may comprise at least one mounting interface for fastening the port flange to at least one of the RF socket and a PCB housing.

[0023] For example, the port flange may be provided with one or several fastening (through) holes for receiving corresponding fastening elements like screws, bolts or the like, which then may enter and engage corresponding holes within the RF socket and/or a PCB housing.

BRIEF DESCRIPTION OF THE DRAWINGS

[0024] For a more complete understanding of the present invention and advantages thereof, reference is now made to the following description taken in conjunction with the accompanying drawings. The invention is explained in more detail below using exemplary embodiments which are specified in the schematic figures of the drawings, in which:

Fig. 1 shows an explosive perspective view of a PCB with an RF connector according to an embodiment of the present invention; and

Fig. 2 shows a detailed perspective view of a centering nut used in the RF connector of Fig. 1.

[0025] The appended drawings are intended to provide further understanding of the embodiments of the invention. They illustrate embodiments and, in conjunction with the description, help to explain principles and concepts of the invention. Other embodiments and many of the advantages mentioned become apparent in view of the drawings. The elements in the drawings are not necessarily shown to scale.

[0026] In the drawings, like, functionally equivalent and identically operating elements, features and components are provided with like reference signs in each case, unless stated otherwise.

DETAILED DESCRIPTION OF THE DRAWINGS

[0027] Figure 1 shows an explosive perspective view of a PCB 1 with an RF connector 10 according to an embodiment of the present invention.

[0028] Radio frequency (RF) and/or coaxial connectors are a key component in RF and microwave applications where they are frequently used in test and measurement equipment to connect coaxial cables with the respective read-out or signal generating system components, e.g. in signal and spectrum analyzers and/or generators, test systems for antennas and other electromagnetic equipment, oscilloscopes etc. In most of these applications it is paramount to utilize connectors that allow accurate and repeatable measurements while being durable and highly performant at the same time.

[0029] Hence, the RF connection with a PCB 1, e.g. being part of an electronic measurement device, should not only be easy to assemble in order to save costs and manufacturing time but should also provide a connection that is mechanically and electrically stable. The presently described solution for an RF connector provides an RF connection that offers all of these advantages.

[0030] Specifically, the RF connector 10 of the exemplary embodiment of Figs. 1 and 2 comprises an RF socket 2 adapted to be mounted to a PCB 1 and providing a coaxial terminal 3 with a first diameter. The RF socket 2 may be placed upon and contacted to the PCB 1 in the usual vein, e.g. by soldering. It may be accommodated in a small box-like or cuboid housing, from which the coaxial terminal 3 protrudes. In order to simplify the soldering process and to facilitate a robust connection to the PCB 1, the coaxial terminal 3 may feature a relatively small diameter (e.g. roughly 4 mm).

[0031] In order to be able to use larger RF plugs in combination with this RF socket 2, the RF connector 10 is complemented by a port flange 4 configured to be plugged on the RF socket 2 and providing a plug-in port 5 with a second larger diameter (e.g. roughly 8 mm) for receiving another RF connector (not shown) to be contacted to the RF socket 2. In this case the port flange 4 is a mechanical plate-shaped retainer having a cylindrical extension with a through-hole serving as plug-in port 5 for other RF connectors and/or cables. The port flange 4 may be plugged at its plug-in port 5 on the coaxial terminal

3 of the RF socket 2.

[0032] In the embodiment of Fig. 1, the port flange 4 comprises two further through-holes as mounting interfaces 8 for fastening the port flange 4 to the RF socket 2 by inserting two fastening elements 9 (e.g. screws) through the mounting interfaces 8 into respective fastening holes 11 in the RF socket 2. In addition, the port flange 4 may also be fastened to a housing of the PCB 1 (not shown in Fig. 1) by similar means in order to further optimize the absorption of mechanical loads and to make the whole assembly more rigid.

[0033] To ensure adequate alignment between the port flange 4 and the RF socket 2 and thus of a coaxial connection with the PCB 1, the RF connector 10 further comprises a centering nut 6 as exemplarily shown in Fig. 2. The centering nut 6 is configured to be disposed between the RF socket 2 and the port flange 4 for centering the port flange 4 with respect to the RF socket 2. To this end, the centering nut 6 is configured with an inner diameter 6a corresponding to the first diameter of the RF socket 2 and an outer diameter 6b corresponding to the second diameter of the port flange 4. The centering nut 6 may be formed from metal with high strength, e.g. steel or a copper-beryllium alloy, to guarantee a mechanically stable and well aligned connection even under long and frequent usage of the assembly.

[0034] In the embodiment of Fig. 2, the centering nut 6 is provided with an inner thread to be screwed upon the coaxial terminal 3 of the RF socket 2 (which is provided with a complementary formed outer thread not shown in Fig. 1). Moreover, the centering nut 6 may feature one or several assembly portions 12 adapted to be engaged by an assembly tool to ease the installation process. In the exemplary embodiment of Fig. 2, the centering nut 6 is provided with two ring-shaped grooves running around the inner and outer diameters of the nut 6, respectively, so that the nut 6 can be engaged by a suitable tool through the plug-in port 5 of the port flange 4 in order to apply a rotary moment to the nut 6.

[0035] Thus assembly of the RF connector 10 may comprise pre-mounting the port flange 4 to the RF socket 2 by plugging it onto the RF socket 2 without (final) fixation (the fastening elements 9 are either not yet inserted or are at least not yet tightened). At this point, the centering nut 6 may have already been placed on the coaxial terminal 3 (also only loosely). Alternatively however, the centering nut 6 may be inserted through the plug-in port 5 of the port flange 4 subsequently. Next, the assembly may comprise screwing the centering nut 6 onto the coaxial terminal 3 of the RF socket 2 with a defined torque for permanent retention. Then, the now centered port flange 4 may be fixed tight, e.g. by screwing it to the RF socket 2. Finally, the port flange 4 may get fastened to a device housing, e.g. by further fastening elements.

[0036] As a result, an RF connector 10 is assembled on top of a PCB 1 featuring a port flange 4 with a large outer diameter for coupling RF connectors and cables to the PCB that is able to withstand high mechanical loads and

stress. The connection is well aligned due to the intermediate nut 6 between the RF socket 2 and the port flange 4, which can be kept permanently within the assembly. The assembly process is simple and straightforward, eliminating the need to apply and remove the commonly used centering tools.

[0037] Although specific embodiments have been illustrated and described herein, it will be appreciated by those of ordinary skill in the art that a variety of alternate and/or equivalent implementations exist. It should be appreciated that the exemplary embodiment or exemplary embodiments are only examples, and are not intended to limit the scope, applicability, or configuration in any way. Rather, the foregoing summary and detailed description will provide those skilled in the art with a convenient road map for implementing at least one exemplary embodiment, it being understood that various changes may be made in the function and arrangement of elements described in an exemplary embodiment without departing from the scope as set forth in the appended claims and their legal equivalents. Generally, this application is intended to cover any adaptations or variations of the specific embodiments discussed herein.

[0038] In the foregoing detailed description, various features are grouped together in one or more examples or examples for the purpose of streamlining the disclosure. It is understood that the above description is intended to be illustrative, and not restrictive. It is intended to cover all alternatives, modifications as may be included within the scope of the invention as defined within the appended claims.

[0039] Specific nomenclature used in the foregoing specification is used to provide a thorough understanding of the invention. However, it will be apparent to one skilled in the art in light of the specification provided herein that the specific details are not required in order to practice the invention. Thus, the foregoing descriptions of specific embodiments of the present invention are presented for purposes of illustration and description. They are not intended to be exhaustive or to limit the invention to the precise forms disclosed; obviously many modifications and variations are possible in view of the above teachings, falling within the scope of the claims as defined in the appended claims. Throughout the specification, the terms "including" and "in which" are used as the plain-English equivalents of the respective terms "comprising" and "wherein," respectively. Moreover, the terms "first," "second," and "third," etc., are used merely as labels, and are not intended to impose numerical requirements on or to establish a certain ranking of importance of their objects.

List of reference signs

[0040]

- 1 printed circuit board (PCB)
- 2 RF socket

- 3 coaxial terminal
- 4 port flange
- 5 plug-in port
- 6 centering nut
- 6a inner diameter
- 6b outer diameter
- 7 inner thread
- 8 mounting interface
- 9 fastening element
- 10 RF connector
- 11 fastening hole
- 12 assembly portion

Claims

1. RF connector (10) for contacting a printed circuit board, PCB, (1), the RF connector (10) comprising:

an RF socket (2) configured to be mounted to the PCB (1), the RF socket (2) providing a coaxial terminal (3) with a first diameter, the first diameter being an outer diameter of the coaxial terminal (3);

a port flange (4) configured to be plugged on the RF socket (2) and comprising a through-hole serving as a plug-in port (5) with a second diameter for receiving another RF connector to be contacted to the RF socket (2), the second diameter being an inner diameter corresponding to the through-hole that is larger than the first diameter; the RF connector being **characterized in that** it further comprises

a centering nut (6) configured to be disposed between the RF socket (2) and the port flange (4) for centering the port flange (4) with respect to the RF socket (2), wherein the centering nut (6) has an inner diameter (6a) corresponding to the first diameter of the RF socket (2) and an outer diameter (6b) corresponding to the second diameter of the port flange (4).

2. RF connector according to claim 1, wherein the centering nut (6) is configured with an inner thread (7) to be screwed upon the RF socket (2).
3. RF connector according to any of the preceding claims, wherein the centering nut (6) is configured with at least one assembly portion (12) adapted to be engaged by an assembly tool.
4. RF connector according to any of the preceding claims, wherein the centering nut (6) is formed from a metal material.
5. RF connector according to any of the preceding claims, wherein the centering nut (6) comprises at least one of steel and copper-beryllium.

6. RF connector according to any of the preceding claims, wherein the port flange (4) comprises at least one mounting interface (8) for fastening the port flange to at least one of the RF socket (2) and a PCB housing.

Patentansprüche

1. HF-Steckverbinder (10) zum Kontaktieren einer Leiterplatte, PCB, (1), der HF-Steckverbinder (10) umfassend:

eine HF-Buchse (2), die konfiguriert ist, um auf der PCB (1) befestigt zu werden, wobei die HF-Buchse (2) eine Koaxialklemme (3) mit einem ersten Durchmesser bereitstellt, wobei der erste Durchmesser ein Außendurchmesser der Koaxialklemme (3) ist;

einen Anschlussflansch (4), der konfiguriert ist, um auf die HF-Buchse (2) aufgesteckt zu werden und umfassend eine als ein Steckanschluss (5) dienende Durchgangsbohrung mit einem zweiten Durchmesser zum Aufnehmen eines weiteren HF-Steckverbinders, um mit der HF-Buchse (2) kontaktiert zu werden, wobei der zweite Durchmesser ein der Durchgangsbohrung entsprechender Innendurchmesser ist, der größer ist als der erste Durchmesser; wobei der HF-Steckverbinder **dadurch gekennzeichnet ist, dass** er ferner eine Zentriermutter (6) umfasst, die konfiguriert ist, um zwischen der HF-Buchse (2) und dem Anschlussflansch (4) angeordnet zu werden, zum Zentrieren des Anschlussflansches (4) in Bezug auf die HF-Buchse (2), wobei die Zentriermutter (6) einen Innendurchmesser (6a), der dem ersten Durchmesser der HF-Buchse (2) entspricht, und einen Außendurchmesser (6b) aufweist, der dem zweiten Durchmesser des Anschlussflansches (4) entspricht.

2. HF-Steckverbinder nach Anspruch 1, wobei die Zentriermutter (6) mit einem Innengewinde (7) konfiguriert ist, um auf die HF-Buchse (2) aufgeschraubt zu werden.
3. HF-Steckverbinder nach einem der vorstehenden Ansprüche, wobei die Zentriermutter (6) mit mindestens einem Montageabschnitt (12) konfiguriert ist, der geeignet ist, um durch ein Montagewerkzeug in Eingriff genommen zu werden.
4. HF-Steckverbinder nach einem der vorstehenden Ansprüche, wobei die Zentriermutter (6) aus einem metallischen Material ausgebildet ist.
5. HF-Steckverbinder nach einem der vorstehenden

Ansprüche, wobei die Zentriermutter (6) mindestens eines von Stahl und Kupfer-Beryllium umfasst.

6. HF-Steckverbinder nach einem der vorstehenden Ansprüche, wobei der Anschlussflansch (4) mindestens eine Montageschnittstelle (8) zum Anbringen des Anschlussflansches an mindestens eines der HF-Buchse (2) und einem PCB-Gehäuse umfasst.

5

6. Connecteur RF selon l'une quelconque des revendications précédentes, dans lequel la bride de port (4) comprend au moins une interface de montage (8) pour fixer la bride de port à au moins l'une des prises RF (2) et à un boîtier de PCB.

10

Revendications

1. Connecteur RF (10) destiné à entrer en contact avec une carte de circuit imprimé, PCB, (1), le connecteur RF (10) comprenant :

15

une prise RF (2) configurée pour être montée sur la PCB (1), la prise RF (2) fournissant une borne coaxiale (3) avec un premier diamètre, le premier diamètre étant un diamètre extérieur de la borne coaxiale (3) ;

20

une bride de port (4) conçue pour être enfichée sur la prise RF (2) et comprenant un trou traversant servant de port d'enfichage (5) avec un second diamètre pour recevoir un autre connecteur RF à mettre en contact avec la prise RF (2), le second diamètre étant un diamètre intérieur correspondant au trou traversant qui est plus grand que le premier diamètre ; le connecteur **RF est caractérisé en ce qu'il** comprend en outre un écrou de centrage (6) conçu pour être disposé entre la prise RF (2) et la bride de port (4) afin de centrer la bride de port (4) par rapport à la prise RF (2), dans lequel l'écrou de centrage (6) ayant un diamètre intérieur (6a) correspondant au premier diamètre de la prise RF (2) et un diamètre extérieur (6b) correspondant au second diamètre de la bride de port (4).

25

30

35

2. Connecteur RF selon la revendication 1, dans lequel l'écrou de centrage (6) est conçu avec un filetage intérieur (7) pour être vissé sur la douille RF (2).

40

3. Connecteur RF selon l'une quelconque des revendications précédentes, dans lequel l'écrou de centrage (6) est conçu avec au moins une partie d'assemblage (12) adaptée pour être engagée par un outil d'assemblage.

45

4. Connecteur RF selon l'une quelconque des revendications précédentes, dans lequel l'écrou de centrage (6) est formé d'un matériau métallique.

50

5. Connecteur RF selon l'une quelconque des revendications précédentes, dans lequel l'écrou de centrage (6) comprend au moins un parmi l'acier et le cuivre-béryllium.

55

Fig. 1

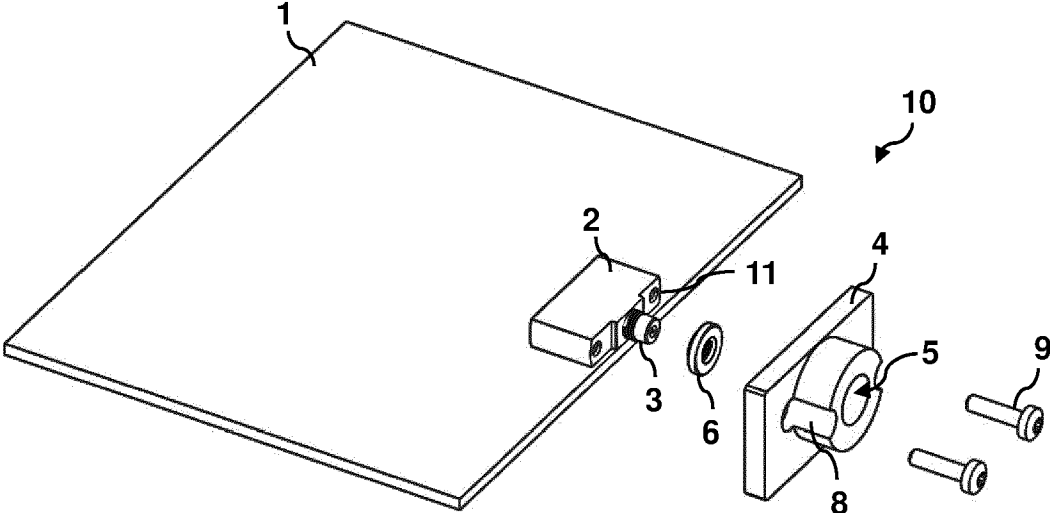
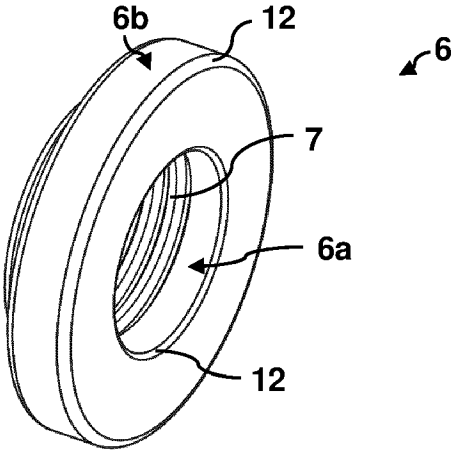

Fig. 2



REFERENCES CITED IN THE DESCRIPTION

This list of references cited by the applicant is for the reader's convenience only. It does not form part of the European patent document. Even though great care has been taken in compiling the references, errors or omissions cannot be excluded and the EPO disclaims all liability in this regard.

Patent documents cited in the description

- EP 3432424 A1 [0004]
- WO 2020006195 A1 [0005]
- US 6824392 B1 [0006]
- JP 2011134720 A [0007]
- GB 2512822 A [0008]