

No. 656,883.

Patented Aug. 28, 1900.

C. B. EAMES.
RAIL JOINT.

(Application filed Jan. 26, 1900.)

(No Model.)

Fig. 1.

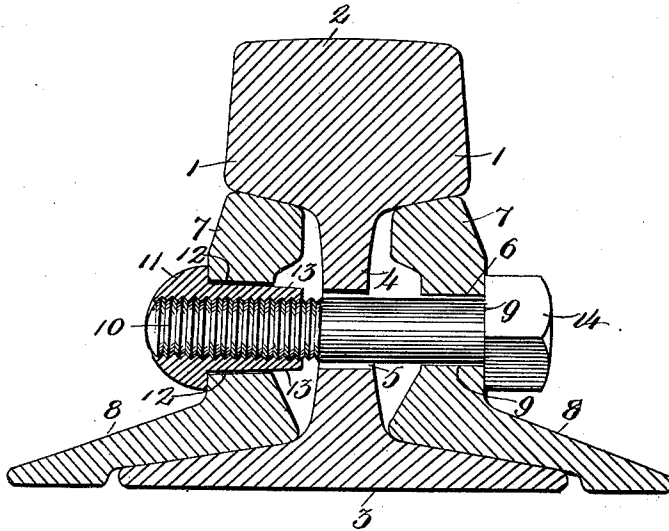

Fig. 2.

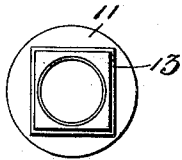
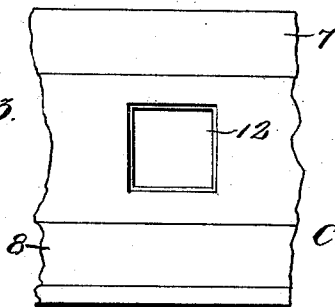

Fig. 3.



WITNESSES:
J. Anderson
V. M. Y. Bette

INVENTOR
Charles B. Eames
BY *Stoll & Geller*
ATTORNEYS.

UNITED STATES PATENT OFFICE.

CHARLES B. EAMES, OF ST. LOUIS, MISSOURI.

RAIL-JOINT.

SPECIFICATION forming part of Letters Patent No. 656,883, dated August 28, 1900.

Application filed January 26, 1900. Serial No. 2,929. (No model.)

To all whom it may concern:

Be it known that I, CHARLES B. EAMES, a citizen of the United States, residing at St. Louis, State of Missouri, have invented new and useful Improvements in Rail-Joints, of which the following is a specification.

My invention relates to improvements in rail-joints; and it consists in the novel combination and arrangement of parts, as will be hereinafter more specifically described and claimed.

In the drawings, Figure 1 is a vertical cross-section of a rail-joint constructed according to my invention, taken through that portion of the several parts adjacent to one of the securing-bolts. Fig. 2 is an end view of the improved nut, and Fig. 3 is a detail side elevation of one of the spring-arch angle-bars for receiving the nut.

The object of my invention is to construct a simple, practical, and durable rail-joint—that is, one that will not only stand the rough usage to which the same is necessarily subjected, but, further, form a practical lock for permanently holding the several parts in a rigid and compact position after the same are clamped together.

Briefly stated, the invention consists in the employment of the ordinary rail without alteration of any character and having the usual openings formed therein adjacent to the meeting ends of the same, vertical spring-arch angle-bars located on either side of the meeting ends of the rails, one of which is provided with openings of smooth bore and the other having openings which are preferably rectangular in shape, nuts having extensions, the latter or said extensions adapted to be freely received by the rectangular openings formed in one of the angle-bars, and bolts having polygonal-shaped heads passing freely through the openings in one of the angle-bars and web portions of the rails, the screw-threaded ends of said bolts being adapted to be received by the screw-threaded openings formed in said nuts, whereby when a wrench or other tool is applied to the heads of the bolts the parts are firmly clamped together and held in a locked position without the employment of additional fastening devices, all of which will be hereinafter more fully described.

Referring to the drawings, 1 represents a rail of ordinary construction and composed of a ball or tread portion 2, base 3, web 4, connecting the tread portion with the base, and openings 5, formed in said web for the free passage of the bolt 6.

The vertical spring-arch angle-bars 7, which are located on either side of the meeting ends of the rails, are each provided with a flanged portion 8, one of said angle-bars being provided with an opening 9, which is circular in shape and adapted to freely receive the bolt 6, the opposite end of the latter having usual screw-threads 10 formed thereon, which are adapted to be received by corresponding screw-threads formed in a nut 11, the latter having an enlarged head which is adapted to come in contact with the outer vertical flat surface of the opposite angle-bar 7, the last-named angle-bar being provided with a rectangular-shaped opening 12, having inclined walls, said opening being adapted to receive the rectangular-shaped extension 13 of said nut, whereby the latter is prevented from turning when the nut 6 is screwed into the same for binding the parts together.

As clearly shown in Fig. 1 of the drawings, the extension 13 of the nut 11 is provided with inclined walls which correspond to the inner walls of the opening 12 of the angle-bar, whereby the said opening will always receive the said extension of the nut, notwithstanding any inaccuracies in forming said opening or extension of the nut, and, further, the said extension is of sufficient length to project beyond the inner surface of the angle-bar, whereby a sufficient number of threads may be formed in the nut for producing a sufficient amount of friction to hold the parts together after the same are brought into a clamped position.

The bolt 6 is provided with a polygonal-shaped head 14, which is adapted to be brought in contact with the outer surface of one of the angle-bars, which head also provides means for turning the bolt by the application of wrench or other tools.

From the construction of the device and the description of its operation as before described it will be readily seen that angle-bars of the usual construction may be employed in carrying out my invention by form-

ing rectangular openings in one set of the same after the usual circular openings have been formed therein, or new angle-bars may be provided for that side of the rail and those
 5 previously formed with circular openings used on the opposite side of the rail without loss of any angle-bars.

I do not limit myself to the rectangular-shaped openings formed in one of the angle-bars, as herein shown and described, as it is
 10 obvious that the same may be elliptical or any other shape and the extensions of the nuts of a similar or corresponding shape, the principal object being to form the parts in
 15 such a manner as to prevent the nuts from turning when the bolts are screwed into the same, and, further, to form the same in such a manner as to provide a sufficient number of screw-threads therein to produce sufficient
 20 friction or resistance to prevent the parts from becoming released by the vibration of a train over the track.

Having fully described my invention, what I claim is—

In combination with an ordinary rail hav- 25
 ing suitable openings formed in the web portion thereof, of angle-bars located on either side of the rail, each of said angle-bars being provided with openings, the openings in one
 30 of said angle-bars being rectangular in shape, nuts having enlarged heads normally in contact with the outer surface of said angle-bars, rectangular-shaped extensions forming a part
 35 of said nuts, and having inclined sides, the said extensions adapted to be received by the rectangular-shaped openings formed in one of the angle-bars, and extending beyond the inner surface of the same, and bolts, the screw-
 40 threaded ends of which are adapted to be received by screw-threaded openings formed in said nuts, and extensions thereof, as and for the purpose described.

In testimony whereof I affix my signature in presence of two witnesses.

CHARLES B. EAMES.

Witnesses:

C. F. KELLER,
 J. ANDERSON.