

(12) STANDARD PATENT
(19) AUSTRALIAN PATENT OFFICE

(11) Application No. **AU 2007209736 B2**

(54) Title
Apparatus for collating flat objects and for conveying the collated objects further

(51) International Patent Classification(s)
B65H 39/055 (2006.01)

(21) Application No: **2007209736** (22) Date of Filing: **2007.01.19**

(87) WIPO No: **WO07/085101**

(30) Priority Data

(31) Number	(32) Date	(33) Country
00118/06	2006.01.25	CH

(43) Publication Date: **2007.08.02**

(44) Accepted Journal Date: **2012.06.14**

(71) Applicant(s)
Ferag AG

(72) Inventor(s)
Honegger, Werner

(74) Agent / Attorney
Griffith Hack, GPO Box 1285, Melbourne, VIC, 3001

(56) Related Art
US 4981291 A
US 5765823 A

(12) NACH DEM VERTRAG ÜBER DIE INTERNATIONALE ZUSAMMENARBEIT AUF DEM GEBIET DES PATENTWESENS (PCT) VERÖFFENTLICHTE INTERNATIONALE ANMELDUNG

(19) Weltorganisation für geistiges Eigentum
Internationales Büro



(43) Internationales Veröffentlichungsdatum
2. August 2007 (02.08.2007)

PCT

(10) Internationale Veröffentlichungsnummer
WO 2007/085101 A1

(51) Internationale Patentklassifikation:
B65H 39/055 (2006.01)

(21) Internationales Aktenzeichen: PCT/CH2007/000026

(22) Internationales Anmeldedatum:
19. Januar 2007 (19.01.2007)

(25) Einreichungssprache: Deutsch

(26) Veröffentlichungssprache: Deutsch

(30) Angaben zur Priorität:
00118/06 25. Januar 2006 (25.01.2006) CH

(71) Anmelder (für alle Bestimmungsstaaten mit Ausnahme von US): FERAG AG [CH/CH]; Zürichstrasse 74, CH-8340 Hinwil (CH).

(72) Erfinder; und

(75) Erfinder/Anmelder (nur für US): HONEGGER, Werner [CH/CH]; Seestrasse 123d, CH-8806 Bäch (CH).

(74) Anwalt: FREI PATENTANWALTSBÜRO AG; Postfach 1771, CH-8032 Zürich (CH).

(81) Bestimmungsstaaten (soweit nicht anders angegeben, für jede verfügbare nationale Schutzrechtsart): AE, AG, AL, AM, AT, AU, AZ, BA, BB, BG, BR, BW, BY, BZ, CA, CH, CN, CO, CR, CU, CZ, DE, DK, DM, DZ, EC, EE, EG, ES, FI, GB, GD, GE, GH, GM, GT, HN, HR, HU, ID, IL, IN, IS, JP, KE, KG, KM, KN, KP, KR, KZ, LA, LC, LK, LR, LS, LT, LU, LV, LY, MA, MD, MG, MK, MN, MW, MX, MY, MZ, NA, NG, NI, NO, NZ, OM, PG, PH, PL, PT, RO, RS, RU, SC, SD, SE, SG, SK, SL, SM, SV, SY, TJ, TM, TN, TR, TT, TZ, UA, UG, US, UZ, VC, VN, ZA, ZM, ZW.

(84) Bestimmungsstaaten (soweit nicht anders angegeben, für jede verfügbare regionale Schutzrechtsart): ARIPO (BW, GH, GM, KE, LS, MW, MZ, NA, SD, SL, SZ, TZ, UG, ZM, ZW), eurasisches (AM, AZ, BY, KG, KZ, MD, RU,

[Fortsetzung auf der nächsten Seite]

(54) Title: APPARATUS FOR COLLATING FLAT OBJECTS AND FOR CONVEYING THE COLLATED OBJECTS FURTHER

(54) Bezeichnung: VORRICHTUNG ZUM ZUSAMMENTRAGEN VON FLACHEN GEGENSTÄNDEN UND ZUM WEITERFÖRDERN DER ZUSAMMENGETRAGENEN GEGENSTÄNDE

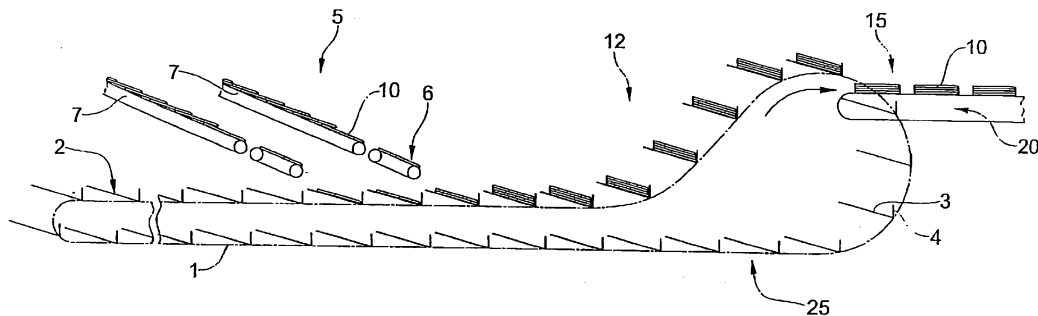

(57) Abstract: Various printed products (10) are fed by feeding units (7) and collated in compartments (2), wherein the compartments (2) are conveyed substantially continuously past the feed openings (6) which are arranged in a row behind one another, and in each case one printed product (10) is added through each feed opening (6). The compartments (2) have a compartment floor (3) and a transverse wall (4), wherein the compartment floor (3) is inclined in the conveying direction at least in a feeding region (5) of the circulating path (1) of the compartments (2), and the transverse wall (4) leads or trails depending on the direction of inclination. The compartments (2) are coupled to a conveying means in such a way that they can be pivoted about a substantially horizontal axis and/or a substantially vertical axis. As a result, it becomes possible to maintain the angle of inclination of the compartments and/or their spatial orientation which they have in the feeding region, in a further-conveying region (12), a removal region (15) and/or a return region (25) having inclines, downward slopes and/or a horizontal projection with directional changes.

(57) Zusammenfassung: Verschiedene Druckprodukte (10) werden von Zuführungseinheiten (7) zugeführt und in Abteilen (2) zusammengetragen, wobei die Abteile (2) im wesentlichen kontinuierlich an den in einer Reihe hintereinander angeordneten Zuführungsausgängen (6) vorbei gefördert werden und durch jeden Führungsausgang (6) je ein Druckprodukt (10) zugegeben wird. Die Abteile (2) haben einen Abteilboden (3) und eine Querwand (4), wobei der Abteilboden (3) mindestens in einem Führungsbereich (5) der Umlaufbahn (1) der Abteile (2) in Förderrichtung geneigt ist und die Querwand (4) je nach Neigungsrichtung vorlaufend oder nachlaufend ist. Die Abteile (2) sind derart an einem Fördermittel angekoppelt, dass sie um eine im wesentlichen horizontale und/oder eine im wesentlichen vertikale Achse verschwenkbar sind. Dadurch wird es möglich, den Neigungswinkel der Abteile und/oder ihre räumliche Ausrichtung, die sie im Führungsbereich haben, in einem Weiterförderbereich (12), einem Entnahmebereich (15) und/oder einem Rückförderbereich (25) mit Steigungen, Gefälle und/oder einem Grundriss mit Richtungswechseln beizubehalten.



WO 2007/085101 A1



TJ, TM), europäisches (AT, BE, BG, CH, CY, CZ, DE, DK, EE, ES, FI, FR, GB, GR, HU, IE, IS, IT, LT, LU, LV, MC, NL, PL, PT, RO, SE, SI, SK, TR), OAPI (BF, BJ, CF, CG, CI, CM, GA, GN, GQ, GW, ML, MR, NE, SN, TD, TG).

Zur Erklärung der Zweibuchstaben-Codes und der anderen Abkürzungen wird auf die Erklärungen ("Guidance Notes on Codes and Abbreviations") am Anfang jeder regulären Ausgabe der PCT-Gazette verwiesen.

Veröffentlicht:

— mit internationalem Recherchenbericht

**DEVICE FOR COLLATING OF FLAT OBJECTS AND FOR CONVEYING
THE COLLATED OBJECTS FURTHER**

The invention is in the field of the processing of piece goods and pertains to a device
5 which serves the purpose of collating flat objects and conveying them further, wherein
the flat objects are in particular printed products.

Collating printed products involves placing different printed products on top of each
other to form stacks, wherein normally identical printed products are superposed in the
same succession in all stacks, the stacks, however, may differ in that in individual
10 stacks individual printed products are not present. The printed products are e.g.
individual, not folded or folded sheets or kerfs folded several times and the printed
products collated to form a stack differ from each other in their printed contents, may,
however, also differ in their shape.

Devices for collating printed products comprise a plurality of feeding units as well as
15 collating means. Each feeding unit is equipped for the feeding of printed products of a
single type into the collating means and the collating means is equipped for the forming
of the stacks from the fed printed products. The outlets of the feeding units directed
towards the collating means is substantially arranged in a successive line and the
collating means comprises a line of compartments for accommodation of the fed printed
20 products, wherein the line of feeding outlets are in parallel to the line of the
compartments. During the feeding steps one compartment is aligned to each feeding
outlet. Furthermore the collating means is equipped for conveying of the fed printed
products in a collating direction parallel to the two named lines. The conveying units
are e.g. feeders, winding stations or on-line connections with devices in which the
25 printed products to be collated are compiled or processed.

In collating devices in which the printed products are fed into the collating means
substantially horizontally to the collating direction the compartments are normally

stationary during the feeding steps and the printed products are moved or tossed into the compartments directed towards the feeding outlets from the side. Between successive feeding steps the printed products together with the compartments are moved in the collating direction over the distance between successive feeding outlets (or by an integral fraction of this distance), such that the compartments directed towards the feeding outlets are replaced by succeeding compartments. The compartments of such devices are normally arranged such that the printed products come to lie horizontally inside them. In publication US-2561070 such a device is described, the compartments of which comprise one corner which is lower down than the other three corners, such that the printed products deposited therein are aligned to one another at this corner by gravity.

Collating devices, the compartments of which are always stationary are also known. In this kind of device the printed products fed into the compartments are, between feeding steps, moved with the aid of a slider from the compartment they were fed to through the succeeding compartments, such that all printed products fed in the preceding step are in one compartment, which is arranged ahead of the foremost feeding outlet. In order for the printed products moved from compartment to compartment to be stacked regularly in such a device it is necessary for the printed products to lie oblique in the collating direction, i.e. that the bases of the compartments are arranged in corresponding oblique manner. Collating devices with the described totally stationary compartments with oblique bases in the collating direction are e.g. described in publications US-1861406, GB-1444487 or EP-0292458.

The disadvantages of the collating devices described in short above, in which the compartments are stationary during the feeding, are in particular based on the thus necessary intermittent operation in which large mass needs to be moved and stopped in relatively fast sequences. This means high energy input, high mechanical wear and restricted conveying speeds and thus restricted output.

Collating devices with compartments moving substantially continuously in the collating direction do not have the named disadvantages. For a problem-free feeding of the printed products into continuously moving compartments the printed products must, however, be substantially aligned and moved or tossed into the compartments in a precisely synchronized manner, wherein also their speed must be adapted to the conveying speed of

the compartments. The collating means of known such devices is e.g. a conveying belt with partitions arranged crosswise and possibly lengthwise to the belt length, wherein two neighbouring partitions define one compartment. In these compartments the fed printed products are stacked lying on the conveying belt. Further known collating devices with continuously conveyed compartments comprise V- or L-shaped compartments in which the fed printed products stand on one edge and lean on walls upstream and a downstream in the collating direction.

Continuously conveyed compartments, in which the printed products are stacked in lying manner are simple to implement (e.g. conveying belt with transverse partitions) and they do not require a high accuracy in feeding because they have large openings and may possibly be larger than the printed products to be fed. Because the compartments must be of relatively large dimensions in the collating direction, high conveying speeds become necessary for high output, which restricts application of the device. Furthermore the stacked printed products in the compartments, especially when these are larger than the printed products, are not actually supported and the stacks are thus not stabilized, which, in particular, for a further conveying with accelerations and/or changes of direction, may lead to increased effort required when extracting the stacks from the compartments or further processing of the stacks.

V- or L-shaped compartments may be conveyed in much closer succession, such that for an equal output the necessary conveying speeds are much lower. Furthermore the printed products stand on one edge in these compartments and automatically remain aligned to one another in relation to this edge due to gravity. On the other hand the openings of the compartments are considerably narrower and a relevantly larger accuracy is required in feeding, not only such that the mostly unguided, downstream edge of a printed product to be fed meets the compartment opening in the first place, but in particular that this downstream edge may be safely led past the upper edges of products already stacked in the compartment. The named high feeding speed restricts the conveying speed and thus the output of the correspondingly equipped collating device. The compartments are possibly also to be equipped with supporting means by which products already stacked within are pressed against a wall in order not to conflict with a further printed product to be fed. With this kind of means the compartments become elaborate and complicated regarding the device and its control.

The invention now has the object to create an alternative device for collating of flat objects.

This object is achieved by the device for collating of flat objects and for conveying of the objects to be collated further as defined in the independent claim. The dependent
5 claims define preferred embodiments of the device.

In an aspect there is provided a device for collating flat objects, in particular printed products and for conveying the collated objects comprising:

- a plurality of feeding units for feeding the objects;
- a plurality of compartments circulating on a circuit for collating the fed objects,
10 wherein the circuit comprises regions with different gradients; a conveyor for conveying the compartments along the circuit and for the substantially continuous conveyance at least through a feeding region of the circuit, wherein outlets of the feeding units in the feeding region are arranged successively in a line and wherein the circuit of the compartments runs in parallel to the named line in the feeding region; and
- 15 - an extractor for removal of the collated objects out of the compartments in an extraction region of the circuit;

wherein the compartments comprise compartment bases for the lying stacking of the objects, at least one object to be oriented with a main surface lying on the base, and a transverse wall and are coupled to the conveyor, such that the compartment bases, at
20 least in the feeding region, are inclined with respect to the horizontal direction and are conveyable in a manner arranged with the transverse wall in transverse to the circuit and such that the compartments are pivotable in relation to the circuit around substantially horizontal and/or around a substantially vertical pivot axis, wherein an angle between a compartment base and the circuit in a first region of the circuit is
25 different from that in another region, and

wherein the base is a longer portion of the compartment as compared to the transverse wall.

In an embodiment in the feeding region, an inclination angle of the compartment bases is between 10° and 45° in the feeding region, with respect to the horizontal direction.

In an embodiment, the inclination angle of the compartment bases is adjustable by means of pivoting around the substantially horizontal pivot axis.

5 In an embodiment at least in the feeding region, the compartment bases are inclined forward as seen in the conveying direction and wherein the transverse wall is leading.

In an embodiment, the circuit, comprises a recirculation region with declining and/or inclining gradients and wherein in at least part of the recirculation region control means are provided, by which the compartments are pivoted in relation to the circuit around
10 the substantially horizontal pivot axis that they maintain their inclination angle from the feeding region.

In an embodiment, the circuit comprises a layout with changes of direction and that at least in regions with changes of direction control means are provided by which the compartments are pivoted around the substantially vertical pivot axis, such that their
15 spatial orientation from before the change of direction is maintained.

In an embodiment, the conveyor comprises a circulating conveying organ on which the compartments are arranged at regular distances.

In an embodiment, the conveyor comprises a plurality of conveying elements as well as driving elements for driving the conveying elements, wherein a compartment is coupled
20 to each conveying element and wherein the conveying elements are conveyable along the circuit at different mutual distances.

In an embodiment, at least a part of the feeding units are feeders, or on-line-feeders.

In an embodiment, the compartment bases are flexible, such that their base planes may

be brought into a convex but not a concave form.

In an embodiment, the compartment bases comprise a plurality of base parts connected in a hinged manner.

5 In an embodiment, the transverse walls are fixed to the compartment bases in a hinged manner.

In an embodiment, the device is integrated in an installation for production of groups of flat objects wrapped in film.

In another aspect there is provided a device for collating flat objects, in particular printed products, and for conveying the collated objects further, comprising:

- 10
- a plurality of feeding units for feeding the objects;
 - a plurality of compartments circulating on a circuit for collating the fed objects;
 - a conveyor for conveying the compartments along the circuit and for the substantially continuous conveyance at least through a feeding region of the circuit, wherein outlets of the feeding units in the feeding region are
- 15
- arranged successively in a line and wherein the circuit of the compartments runs in parallel to the named line in the feeding region; and
 - an extractor for removal of the collated objects out of the compartments in an extraction region of the circuit;
- 20
- wherein the compartments comprise compartment bases for the lying stacking of the objects and a transverse wall and are coupled to the conveyor, such that the compartment bases, at least in the feeding region, are inclined with respect to the horizontal direction and are conveyable in a manner arranged with the transverse wall in transverse to the circuit and
- 25
- such that the compartments are pivotable in relation to the circuit around substantially horizontal and/or around a substantially vertical pivot axis, and

wherein the circuit of compartments, between the feeding region and the extraction region or between parts of the feeding region, comprises at least one region for further conveying, in which the circuit comprises an upward or downward gradient, and
5 wherein the region for further conveying is provided with control means by which the compartments are pivoted in relation to the circuit around the substantially horizontal pivot axis in a manner that the inclination angle from the feeding region is maintained.

In another aspect there is provided a device for collating flat objects, in particular printed products, and for conveying the collated objects further, comprising:

- 10
- a plurality of feeding units for feeding the objects;
 - a plurality of compartments circulating on a circuit for collating the fed objects; a conveyor for conveying the compartments along the circuit and for the substantially continuous conveyance at least through a feeding region of the circuit, wherein outlets of the feeding units in the feeding region are
15 arranged successively in a line and wherein the circuit of the compartments runs in parallel to the named line in the feeding region; and
 - an extractor for removal of the collated objects out of the compartments in an extraction region of the circuit;

20 wherein the compartments comprise compartment bases for the lying stacking of the objects, at least one object to be oriented with a main surface lying on the base, and a transverse wall and are coupled to the conveyor, such that the compartment bases, at least in the feeding region, are inclined with respect to the horizontal direction and are conveyable in a manner arranged with the transverse wall in transverse to the circuit and such that
25 the compartments are pivotable in relation to the circuit around substantially horizontal and/or around a substantially vertical pivot axis,

wherein the base is a longer portion of the compartment as compared to the transverse wall; and

wherein the circuit of the compartments leads downwards in the extraction region and

wherein in the extraction, region control means are provided by which the compartments are pivoted in relation to the circuit around the substantially horizontal pivot axis, such that their inclination angle from the feeding region is maintained.

5 The invention also extends to use of the above device for production of groups of flat objects, wherein the objects are newspapers, magazines, individual folded or not folded sheets, CDs, flat product samples, cards and/or slips or cards pasted to one of the named objects.

The device according to an embodiment of the invention is described in more detail in connection with the following figures, whereby:

10 **Figure 1** shows a very diagrammatic representation of an exemplified embodiment of the device according to the invention in which the compartments are rotatable around a substantially horizontal rotation axis;

Figure 2 the compartments of the device according to Figure 1 in larger scale in the feeding region and in a conveying further region;

15 **Figure 3** shows a very diagrammatic representation of an exemplified control of the compartments of the device according to Figures 1 and 2 for the maintaining of the spatial position in a further conveying with changing upwards inclination:

Figures 4 and 5 show examples of means for extraction of stacked printed products out of the compartments of the device according to Figures 1 and 2;

20 **Figure 6** shows a top view on the feeding region and a region of conveying further of a device according to the invention with compartments which are rotatable around a substantially vertical rotation axis;

Figures 7 and 8 show an advantageous embodiment of the compartments for the device

according to the invention;

Figure 9 shows a redirection of the compartments according to Figures 7 and 8;

Figure 10 shows an exemplified application of the device according to the invention.

Figure 1 shows in a very diagrammatic manner an exemplified embodiment of the device according to the invention viewed from the side. The device comprises, on a circuit 1 (broken line), substantially continuously circulating compartments 2, which comprise, at least in one feeding region 5 (in the upper part of the circuit) a base 2 inclined towards the front in circulation direction and a downstream transverse wall 4. The circuit 1, in the feeding region 5, runs in parallel to a line of outlets 6 from feeding units 7 (only partly shown), with the aid of which printed products 10 are fed into the compartments 2 in identically orientated and synchronized manner. Hereby the feeding is advantageously controlled in a manner that the downstream edge of the printed products to be fed meets a downstream region of the compartment or the printed products already stacked in the compartment or the transverse wall 4 and that the speed of the impinging printed product is slightly higher than the speed of the compartments 2, such that the fed printed product is pushed towards the transverse wall 4 of the compartment 2 and thus is aligned to printed products fed before or after and remains aligned by gravity.

The compartments 2 are coupled to a conveying means (e.g. conveying chain or pair of conveying chains), such that they are rotatable in relation to the conveying means or the circuit 1 respectively around a substantially horizontally directed rotation axis. In a region 12 for conveying further, which comprises different gradients, following a feeding region 5, in which the conveying direction is e.g. horizontal, the compartments 2 with the printed products 10 stacked therein are maintained in the same spatial position by being rotated in relation to the conveying means or the circuit respectively. In other words this means that the inclination angle of the compartments remains the same all the time. In an extraction region 15, following a conveying further region 12 in which the circuit has a gradient, i.e. where the compartments are conveyed downwards, the gradient angle of the compartment bases 3 is also maintained constant and the printed products 10 stacked in the compartments 2 are removed from the compartments 2 by means of an extraction means 20. The extraction region 15 is followed by a recirculation region 25, in which the compartments 2 are brought back into the feeding region 5.

In the recirculation region 25 the spatial position or the gradient respectively of the compartments is not relevant, except if individual stacks, e.g. due to faultiness, cannot be removed from their compartment in the extraction region 15 and need to be recirculated. In such a case it is advantageous for the spatial position of compartments 2 to be

maintained also in the recirculation region 25 or in parts of it, as shown in Figure 1. Obviously, after the redirection into the recirculation region 25, the compartment bases are inclined to the back and the transverse wall 4 is upstream.

The compartments 2 of the device according to the invention are, as mentioned above, e.g. arranged on a conveying chain (not shown) circulating on the circuit 1 or on a pair of such conveying chains, wherein the compartments have regular distances between them. The compartments may also be coupled to loosely connected or mutually independent conveying elements, which are movable along rails, such that the compartments are at different distances from each other in different regions of their circuit. Compartments 2 conveyed independently to a limited degree, may e.g. be conveyed through the feeding region 5 at maximal distance from each other (no or only minor overlap of successive compartments with small gradients), in the extraction region 15 again at large mutual distances and in the region for further conveying 12 and in the recirculation region 25, in particular when the circuit rises in these regions, at a considerably smaller mutual distance (maximal overlap). In such a case also a region of rising or sloping gradient of the circuit 1 is suitable for buffering the compartments or for not loaded compartments (recirculation region) a horizontal region, in which the compartments have a large inclination angle and thus may be conveyed at very small mutual distances.

The compartments 2 shown in Figure 1 comprise, in the feeding region 5 in conveying direction, compartment bases 3 inclining towards the front and a downstream transverse wall 4. The base gradient may also be directed towards the back, wherein the compartments comprise an upstream transverse wall and the feeding speed is to be smaller than the conveying speed of the compartments 2, such that the compartments catch up with an added product, which is thus pushed against the transverse wall and aligned to it.

Figure 2 shows more in detail the transition between the feeding region 5 and the region 12 for conveying further of the circuit 1 of the compartments 2 of the device according to Figure 1. The compartments 2 are narrower than the printed products 10, which are fed into the compartments 2, such that the printed products protrude from the compartment base on both sides and may be lifted by an extraction means (not shown) in this region. As mentioned further above gaps are possible for the same purpose, i.e. the compartments

2 consist of a plurality of mutually distanced parts thus forming a gap, through which an extraction means may act on the printed products 10.

Figure 3 in very diagrammatic manner again shows the transition from the feeding region 5 to the further conveying region 12 of the compartments 2 of the device according to Figure 1, wherein in particular an exemplified control is shown in which the compartments 2 are maintained in the same spatial position independently of the course of the circuit 1, which they have in the feeding region 5. The compartments 2 are mounted to a conveying means (not shown) such that they are, in relation to it, rotatable around the downstream edge of the compartment base 3 (substantially horizontal rotation axis). Under the upstream region of the base 3 control rollers 30 are arranged, which roll off on a stationary cam (broken line 31), when the compartments 2 move along the circuit 1. The distance between the cam 31 and the conveying organ or the circuit 1 is adapted to the gradient of the circuit 1 such that the gradient of the compartment bases 3 remains constant in independence of the gradient of the circuit. For adaptation of the inclination angle of the compartment bases to the printed products to be handled the cam 31 may be adjustable.

Figures 4 and 5 show two exemplified embodiments of extraction regions 15 of the device according to Figures 1 and 2. In these extraction regions 15 extraction means 20 are arranged, with which the printed products 10 stacked in the compartments 2 are removed. In both shown cases the circuit 1 of the compartments 2 runs downwards through the extraction region at a constant inclination angle of the compartment bases and the printed products are lifted from the compartment bases by the extraction means 20.

Figure 4 shows an extraction means 20, which is designed as a plurality of conveying belts 21 (only one is visible) circulating in parallel to each other. The bearing surface of the belts is substantially horizontal and dissects the circuit 1 of the compartments 2 leading downwards. The conveying belt 21 hereby acts laterally from the compartments 2 and/or through gaps in the compartments 2. The stacks conveyed in the compartments 10 are lifted one after the other from the compartment base and conveyed further successively on the conveying belts.

According to **Figure 5** the extraction means 20 is a very diagrammatically shown

gripper-conveyor 22 or a plurality of gripper-conveyors. The circuit 23 of the gripper-conveyor 22 dissects the circuit 1 of the compartments 2 and the grippers 24 move laterally and/or in the gaps of the compartments 2. Furthermore the control means (not shown) are provided, with the help of which the grippers 24 are, where they cross the compartments 2, closed. Advantageously the speeds of the compartments 2 and the gripper 24 are matched such that the stacks of printed products are pushed into the open grippers 24, before the grippers close and before the stack is lifted from the compartment base.

Figure 6 shows a further exemplified embodiment of the device according to the invention in a top view on a transition between the feeding region 5 and a region for further conveyance 12. The feeding region 5 is also shown as a side view, which shows that the compartments 2 are conveyed through the feeding region 5 in the same manner as shown in the preceding figures, i.e. with compartment bases sloping downwards to the front and a downstream transverse wall 4.

The compartments are rotatable around a substantially vertical rotation axis in relation to the conveying means or the circuit 1 respectively, such that they may maintain their spatial orientation through a change of direction in a horizontal plane, as shown in Figure 6 for the region of further conveyance 12, in which the conveying direction is deflected by 90° in relation to the feeding region 5. The control of the compartments is in this case implemented in actually known manner e.g. with the help of control rollers mounted to the compartments and corresponding stationary or adjustable cams.

Obviously with a combination of rotatability around a substantially vertical rotation axis it becomes possible to maintain the spatial position and orientation of the compartments if the circuit is a three-dimensional structure. It also becomes possible not only to change the inclination angle of the compartment bases but also the direction of the inclination gradient in relation to the circuit, such that at constant conveying direction e.g. the inclination towards the front may be orientated towards the back or laterally.

Figures 7 and 8 show an exemplified embodiment of the compartment 2 for the inventive device, as e.g. shown in the Figures 1 and 2. The compartment 2 is shown in a side view. The compartment base 3 consists of a plurality of floor elements 3.1, which,

are connected to each other by means of hinges 3.2 such that the floor plane may be brought into a convex (curved towards the top) form, but not into a concave (curved towards the bottom) form. For this purpose the floor pieces 3.1 comprise regions 3.3 curved downwards on both sides, on which the hinges 3.2 are arranged, as is shown at a slightly larger scale in Figure 8. Advantageously the transverse wall 4 is also arranged to hinge on the base 3 and is held in its operative position by means of a not shown return spring.

Figure 9 shows an extraction region 15, which is arranged in a redirection 32 of the circuit 1 of the compartments 2. The extraction means 20 is a conveying belt 33, which need not engage laterally or in gaps of the compartments but simply connects to the upper hoistway of the compartment circuit 1. As the compartment bases 3 are flexible due to their hinges the distance between the compartment redirection 32 and the extraction means 20 may be very small, such that also stacks with little rigidity may be removed safely. In order to enable the named distance to also be smaller than the height of the transverse walls 4 these are, as mentioned further above, arranged in a hinged manner on the compartment base 3 and in the region of the redirection 32 a control cam 34 is provided, with the help of which the transverse walls 4 are rotated towards the compartment base 3 against the force of the not shown return spring and in this rotated position are moved between the deflection wheel 35 and the extraction means 20.

Figure 9 also shows how the hinges 3.2 may co-operate with corresponding recesses 3.5 of the redirection wheel 35 for the drive of the compartments 2.

Obviously the compartments shown in Figures 7 to 9, the base planes of which may be brought into a convex form, are also applicable in very simple devices, in which the compartments 2 are neither rotatable around a substantially horizontal nor a substantially vertical rotation axis in relation to conveying means or circuit.

Figure 10 shows an exemplified application of the device according to the invention. This is a production installation for production of printed products with other flat objects integrated, wrapped in film, wherein the groups are e.g. units ready for dispatch, which e.g. comprise a newspaper or magazine, possibly with inserted supplements as main products as well as four further supplements such as printed sheets, brochures, booklets,

CDs, flat product samples or slips pasted to these (Memostick®) or cards in form of a stack. For the feeding of printed products to be pasted similar devices to those for the feeding of the other objects are applied in known manner. In addition, an in fact known device is provided with which an adhesive agent is applied and activated and with
5 which the printed product to be pasted is pressed onto the object beneath it in the stack.

In the installation according to Figure 10 the device according to the invention comprises four feeders 40 acting as feeding units as well as an on-line-feeder 41 which e.g. feeds the main product out of a processing device 43 (e.g. inserting drum, collecting drum, cutting machine) and forms the last feeding unit in the collating
10 direction. The shown feeders 40 are arranged directly above the circuit of the compartments. The feeders may also be arranged laterally to the circuit, wherein an e.g. looped intermediate conveyor leads the printed products individualized by the feeder over the compartments and dispenses them into these.

Between the feeding units 40 and the on-line-feeder 41 a rising region 12 for further
15 conveying is arranged. In the extraction region 15 the collated objects, in the manner shown in Figure 4, are taken over by conveying belts. Then they are e.g. held in a device 44 between two tapes and e.g. positioned on a web of film. The web of film is then wrapped around the successive stacks (wrapping region 45). With the aid of a welding device 46 the film wrapped around the stacks is welded lengthwise and
20 transversally and separated. The individual packages formed through the separation are then ordered into a scaled stream (device 47), which is then taken over by a gripper conveyor.

The main product, which possibly also carries the address of the receiver of the completed package, is, as is shown in Figure 10, advantageously fed last and with the
25 title page on top, such that it is clearly visible in the completed package. It is, however, also possible to feed the main product with the title page towards the bottom, i.e. to arrange the on-line feeding in conveying direction as first feeding unit.

In the claims which follow and in the preceding description of the invention, except

where the context requires otherwise due to express language or necessary implication, the word “comprise” or variations such as “comprises” or “comprising” is used in an inclusive sense, i.e. to specify the presence of the stated features but not to preclude the presence or addition of further features in various embodiments of the invention.

- 5 It is to be understood that, if any prior art publication is referred to herein, such reference does not constitute an admission that the publication forms a part of the common general knowledge in the art, in Australia or any other country.

THE CLAIMS DEFINING THE INVENTION ARE AS FOLLOWS:

1. Device for collating flat objects, in particular printed products, and for conveying the collated objects further, comprising:

- a plurality of feeding units for feeding the objects;

5 - a plurality of compartments circulating on a circuit for collating the fed objects, wherein the circuit comprises regions with different gradients; a conveyor for conveying the compartments along the circuit and for the substantially continuous conveyance at least through a feeding region of the circuit, wherein outlets of the feeding units in the feeding region are arranged successively in a line and wherein the circuit of the compartments runs in parallel to the named line in the feeding region; and

10 - an extractor for removal of the collated objects out of the compartments in an extraction region of the circuit;

15 wherein the compartments comprise compartment bases for the lying stacking of the objects, at least one object to be oriented with a main surface lying on the base, and a transverse wall and are coupled to the conveyor, such that the compartment bases, at least in the feeding region, are inclined with respect to the horizontal direction and are conveyable in a manner arranged with the transverse wall in transverse to the circuit and such that

20 the compartments are pivotable in relation to the circuit around substantially horizontal and/or around a substantially vertical pivot axis, wherein an angle between a compartment base and the circuit in a first region of the circuit is different from that in another region, and

25 wherein the base is a longer portion of the compartment as compared to the transverse wall.

2. Device according to claim 1, wherein in the feeding region an inclination angle of the compartment bases is between 10° and 45° with respect to the horizontal

direction.

3. Device according to claim 2, wherein the inclination angle of the compartment bases is adjustable by means of pivoting around the substantially horizontal pivot axis.
4. Device according to claim 1, wherein at least in the feeding region the compartment bases are inclined forward as seen in the conveying direction and wherein the transverse wall is leading.
5. Device according to claim 1, wherein the circuit comprises a recirculation region with declining and/or inclining gradients and wherein in at least part of the recirculation region, control means are provided, by which the compartments are pivoted in relation to the circuit around the substantially horizontal pivot axis that they maintain their inclination angle from the feeding region.
6. Device according to claim 1, wherein the circuit comprises a layout with changes of direction and that at least in regions with changes of direction control means are provided by which the compartments are pivoted around the substantially vertical pivot axis, such that their spatial orientation from before the change of direction is maintained.
7. Device according to claim 1, wherein the conveyor comprises a circulating conveying organ on which the compartments are arranged at regular distances.
8. Device according to claim 1, wherein the conveyor comprises a plurality of conveying elements as well as driving elements for driving the conveying elements, wherein a compartment is coupled to each conveying element and wherein the conveying elements are conveyable along the circuit at different mutual distances.
9. Device according to claim 1, wherein at least a part of the feeding units are feeders or on-line-feeders.

10. Device according to claim 1, wherein the compartment bases are flexible, such that their base planes may be brought into a convex, but not a concave form.
11. Device according to claim 10, wherein the compartment bases comprise a plurality of base parts connected in a hinged manner.
- 5 12. Device according to claim 10, wherein the transverse walls are fixed to the compartment bases in a hinged manner.
13. Device according to claim 1, wherein the device is integrated in an installation for production of groups of flat objects wrapped in film.
14. Use of the device according to claim 1 for production of groups of flat objects,
10 wherein the objects are newspapers, magazines individual folded or not folded sheets, CDs, flat product samples, cards and/or slips or cards pasted to one of the named objects.
15. Device for collating flat objects, in particular printed products, and for conveying the collated objects further, comprising:
- 15 - a plurality of feeding units for feeding the objects;
- a plurality of compartments circulating on a circuit for collating the fed objects;
- a conveyor for conveying the compartments along the circuit and for the substantially continuous conveyance at least through a feeding region of the
20 circuit, wherein outlets of the feeding units in the feeding region are arranged successively in a line and wherein the circuit of the compartments runs in parallel to the named line in the feeding region; and
- an extractor for removal of the collated objects out of the compartments in an extraction region of the circuit;
- 25 wherein the compartments comprise compartment bases for the lying

5 stacking of the objects and a transverse wall and are coupled to the conveyor, such that the compartment bases, at least in the feeding region, are inclined with respect to the horizontal direction and are conveyable in a manner arranged with the transverse wall in transverse to the circuit and such that the compartments are pivotable in relation to the circuit around
10 substantially horizontal and/or around a substantially vertical pivot axis, and wherein the circuit of compartments, between the feeding region and the extraction region or between parts of the feeding region, comprises at least one region for further conveying, in which the circuit comprises an upward or downward gradient, and wherein the region for further conveying is provided with control means by which the compartments are pivoted in relation to the circuit around the substantially horizontal pivot axis in a manner that the inclination angle from the feeding region is maintained.

15 16. Device for collating flat objects, in particular printed products, and for conveying the collated objects further, comprising:

- a plurality of feeding units for feeding the objects;
- a plurality of compartments circulating on a circuit for collating the fed objects; a conveyor for conveying the compartments along the circuit and for the substantially continuous conveyance at least through a feeding region
20 of the circuit, wherein outlets of the feeding units in the feeding region are arranged successively in a line and wherein the circuit of the compartments runs in parallel to the named line in the feeding region; and
- an extractor for removal of the collated objects out of the compartments in an extraction region of the circuit;

25 wherein the compartments comprise compartment bases for the lying stacking of the objects, at least one object to be oriented with a main surface lying on the base, and a transverse wall and are coupled to the conveyor, such that the compartment bases, at least in the feeding region, are inclined with respect to the horizontal direction and are conveyable in a manner
30 arranged with the transverse wall in transverse to the circuit and such that

the compartments are pivotable in relation to the circuit around substantially horizontal and/or around a substantially vertical pivot axis,

wherein the base is a longer portion of the compartment as compared to the transverse wall; and

5 wherein the circuit of the compartments leads downwards in the extraction region and wherein in the extraction, region control means are provided by which the compartments are pivoted in relation to the circuit around the substantially horizontal pivot axis, such that their inclination angle from the feeding region is maintained.

10 17. Device according to claim 16, wherein the extractor is arranged in the extraction region such that it lifts the objects to be collated from the side of the compartments or through gaps in the compartments off the compartment bases.

18. Device according to claim 17, wherein the extractor comprises a plurality of conveying belts circulating in parallel with a substantially horizontal bearing surface.

15 19. Device for collating flat objects, in particular printed products, and for conveying the collated objects further, comprising:

- a plurality of feeding units for feeding the objects;
- a plurality of compartments circulating on a circuit for collating the fed objects;
- 20 - a conveyor for conveying the compartments along the circuit and for the substantially continuous conveyance at least through a feeding region of the circuit, wherein outlets of the feeding units in the feeding region are arranged successively in a line and wherein the circuit of the compartments runs in parallel to the named line in the feeding region; and
- 25 - an extractor for removal of the collated objects out of the compartments in an extraction region of the circuit;

wherein the compartments comprise compartment bases for the lying

5 stacking of the objects and a transverse wall and are coupled to the conveyor, such that the compartment bases, at least in the feeding region, are inclined with respect to the horizontal direction and are conveyable in a manner arranged with the transverse wall in transverse to the circuit and such that the compartments are pivotable in relation to the circuit around substantially horizontal and/or around a substantially vertical pivot axis, and wherein the extractor comprises a gripper-conveyor or a plurality of gripper-conveyors circulating in parallel, wherein a circuit of the gripper-conveyors crosses the circuit of the compartments.

10 20. A device substantially as herein described with reference to the accompanying drawings.

Fig.2

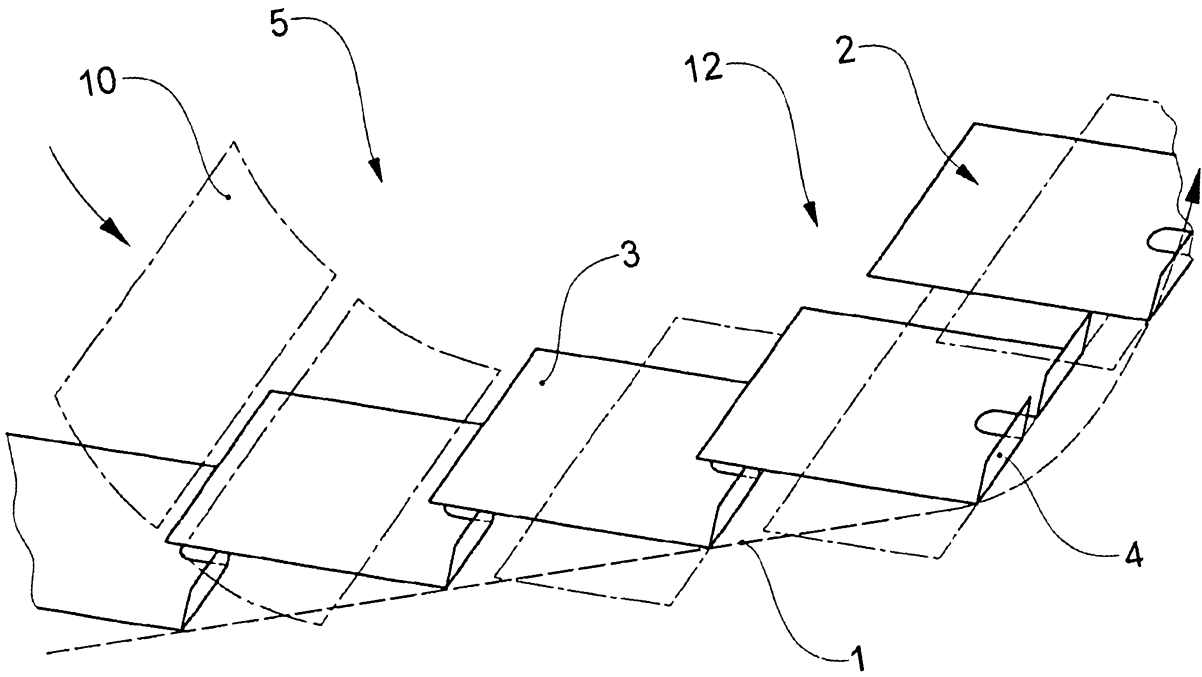
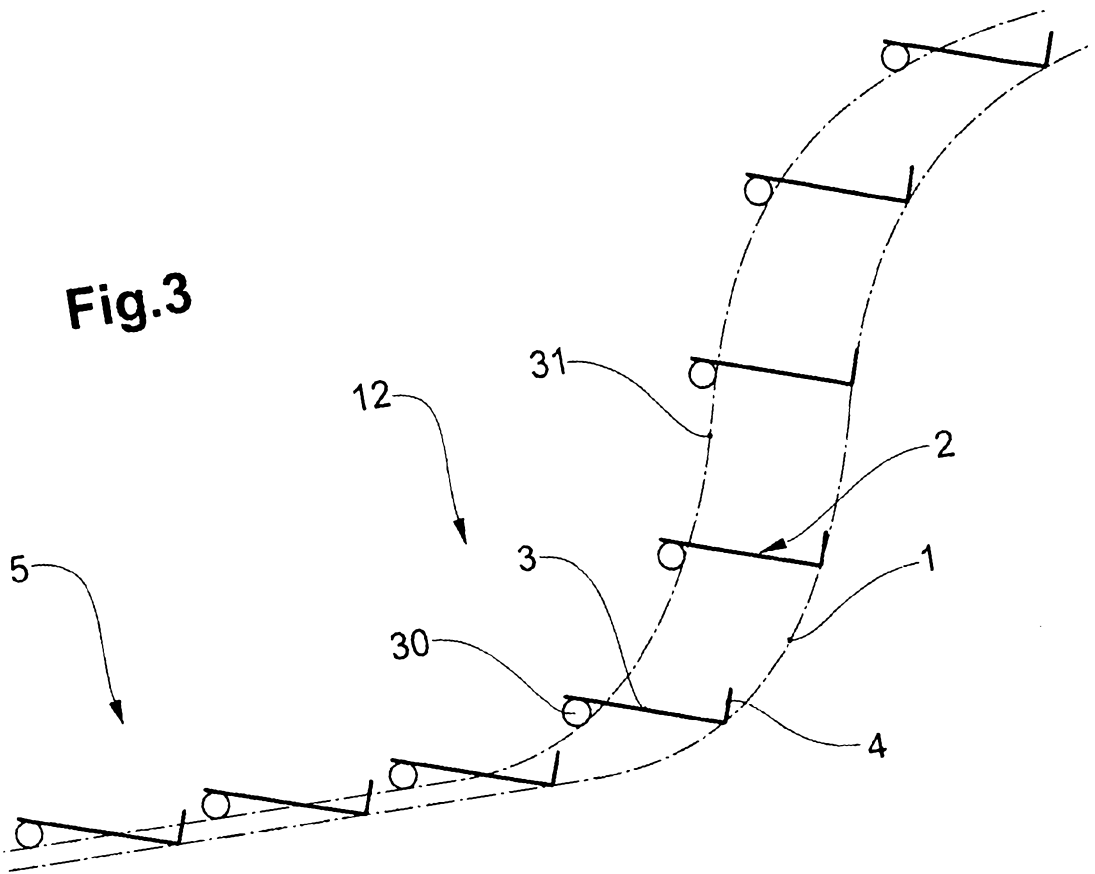

Fig.3



2007209736

Fig.4

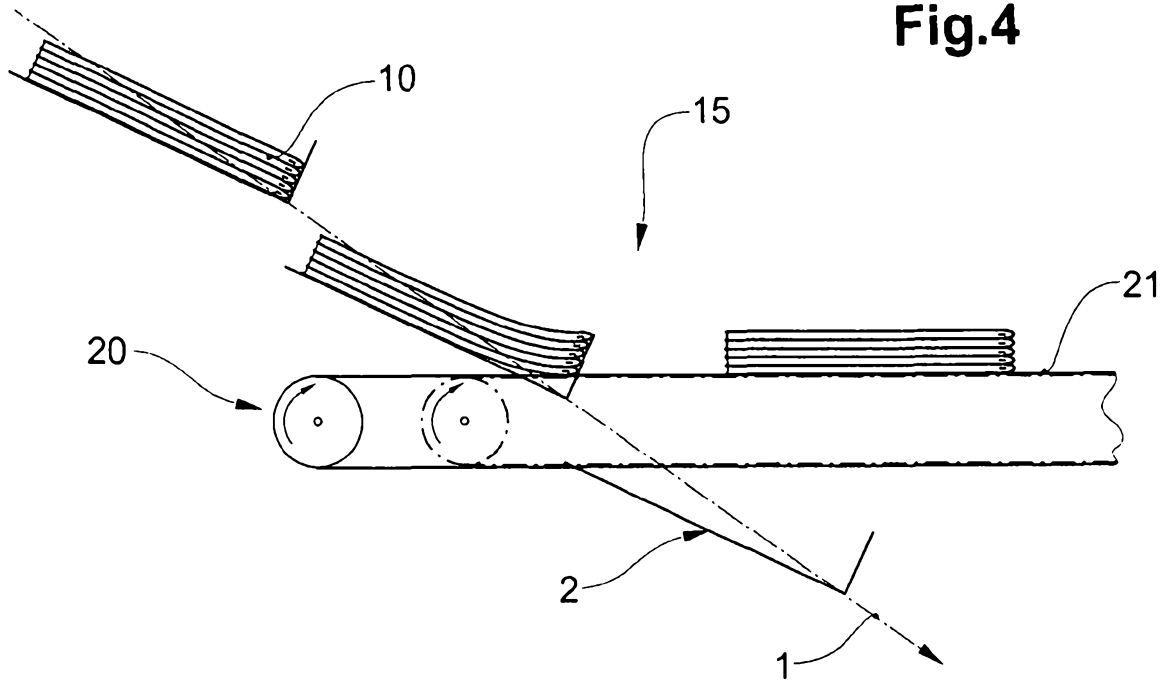

Fig.5

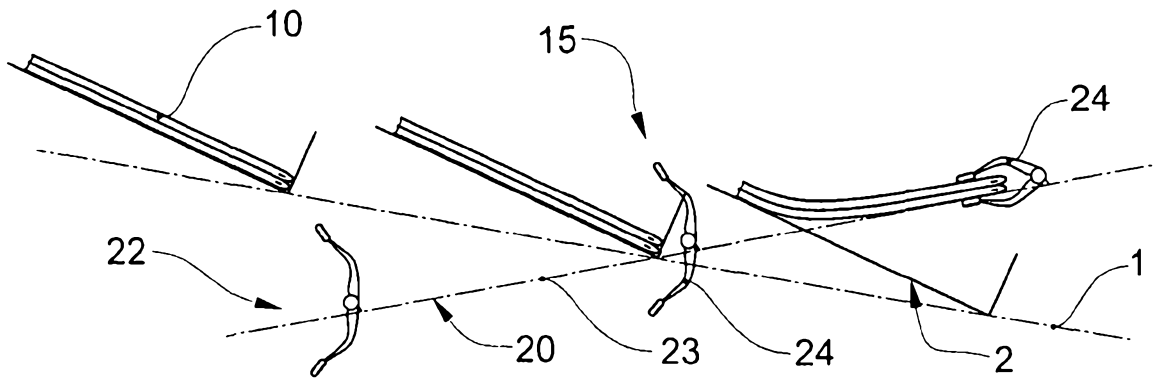

Fig.6

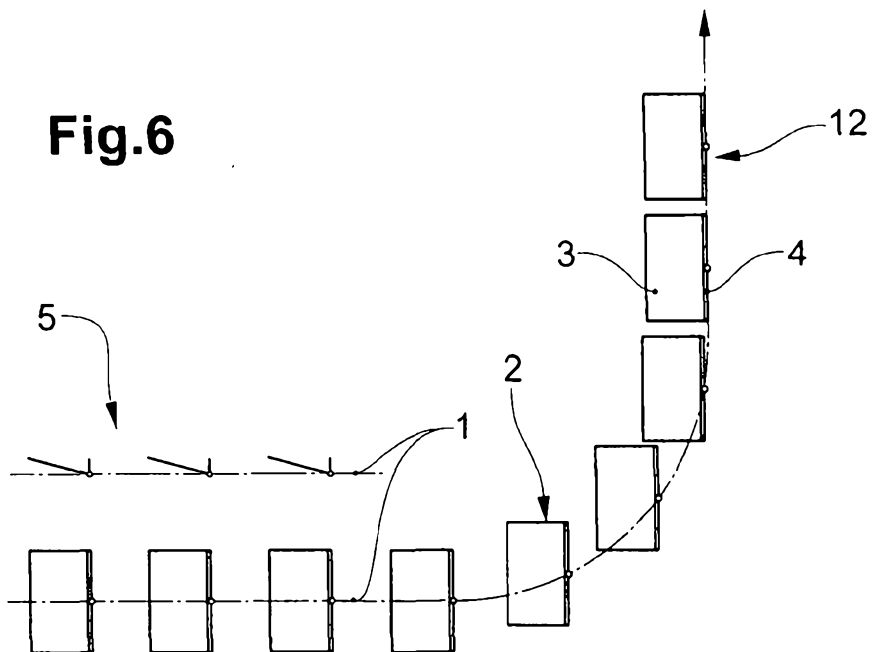

Fig.7

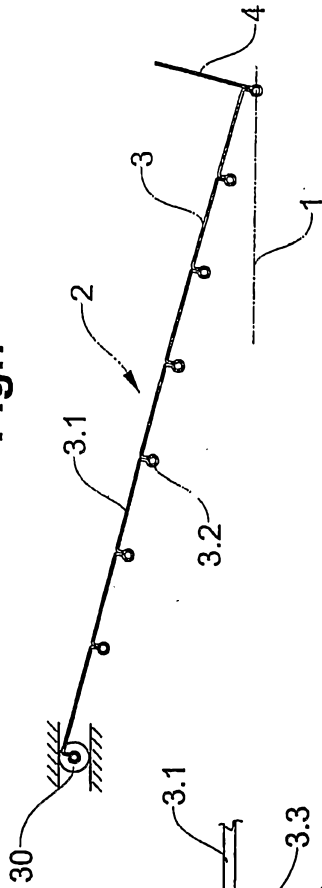

Fig.8

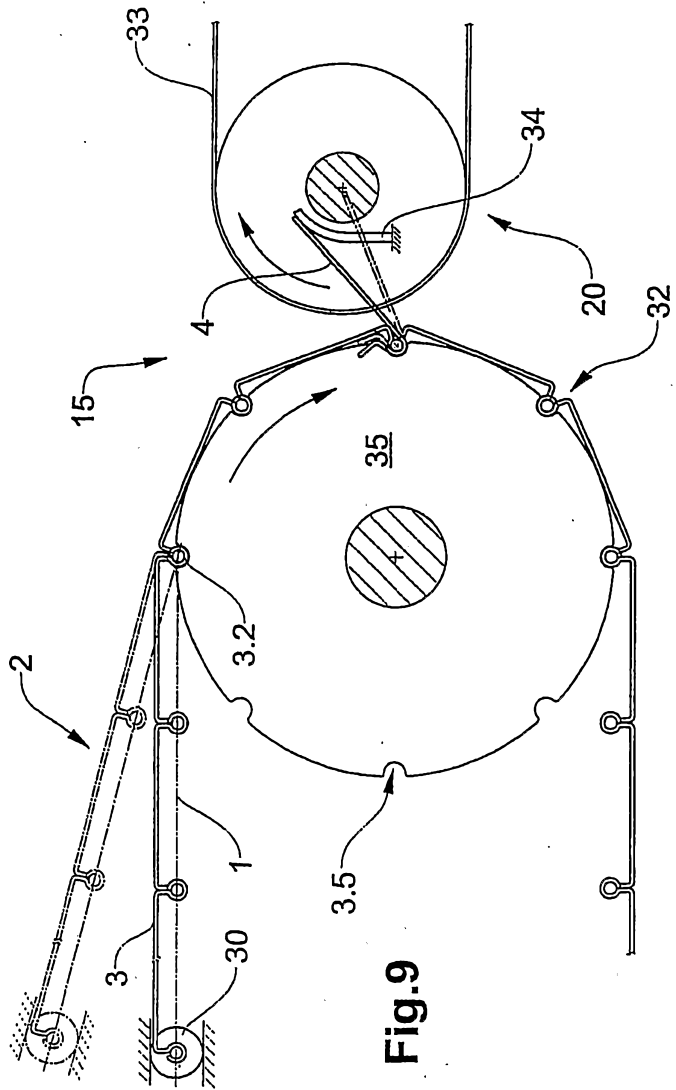
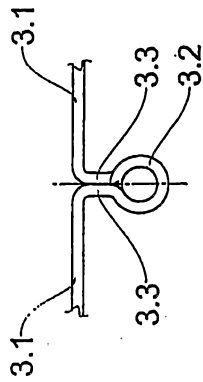

Fig.9