

(19) World Intellectual Property Organization
International Bureau



(43) International Publication Date
23 February 2006 (23.02.2006)

PCT

(10) International Publication Number
WO 2006/020809 A2

(51) International Patent Classification:
E21B 23/00 (2006.01)

(21) International Application Number:
PCT/US2005/028641

(22) International Filing Date: 11 August 2005 (11.08.2005)

(25) Filing Language: English

(26) Publication Language: English

(30) Priority Data:
60/600,679 11 August 2004 (11.08.2004) US

(71) Applicant (for all designated States except US): **EN-VENTURE GLOBAL TECHNOLOGY, LLC** [US/US]; 15995 North Barkers Landing, Suite 350, Houston, TX 77084 (US).

(72) Inventors; and

(75) Inventors/Applicants (for US only): **BRISCO, David, Paul** [US/US]; 405 Westridge Drive, Duncan, OK 73533 (US). **WATSON, Brock, Wayne** [US/US]; 2535 Marsh Lane, # 1004, Carrollton, TX 75006 (US). **SHUSTER, Mark** [US/US]; 19115 Prospect Lane, Houston, TX

77094 (US). **GRAY, Malcolm** [US/US]; 1502 Wagon Gap Trail, Houston, TX 77010 (US). **GRINBERG, Grigoriy** [US/US]; 4758 Mount Airy, Sylvania, OH 43560 (US). **COSTA, Scott** [US/US]; 25614 Broadcrest Court, Katy, TX 77494 (US). **WASSON, Russell** [US/US]; 2647 Highway J, Bourbon, MO 65441 (US).

(74) Agents: **HAYNES AND BOONE LLP** et al.; 901 Main Street, Suite 3100, Dallas, TX 75202 (US).

(81) Designated States (unless otherwise indicated, for every kind of national protection available): AE, AG, AL, AM, AT, AU, AZ, BA, BB, BG, BR, BW, BY, BZ, CA, CH, CN, CO, CR, CU, CZ, DE, DK, DM, DZ, EC, EE, EG, ES, FI, GB, GD, GE, GH, GM, HR, HU, ID, IL, IN, IS, JP, KE, KG, KM, KP, KR, KZ, LC, LK, LR, LS, LT, LU, LV, MA, MD, MG, MK, MN, MW, MX, MZ, NA, NG, NI, NO, NZ, OM, PG, PH, PL, PT, RO, RU, SC, SD, SE, SG, SK, SL, SM, SY, TJ, TM, TN, TR, TT, TZ, UA, UG, US, UZ, VC, VN, YU, ZA, ZM, ZW.

(84) Designated States (unless otherwise indicated, for every kind of regional protection available): ARIPO (BW, GH,

[Continued on next page]

(54) Title: EXPANDABLE TUBULAR MEMBER HAVING VARIABLE MATERIAL PROPERTIES

(57) Abstract: An expandable tubular member having variable material properties.

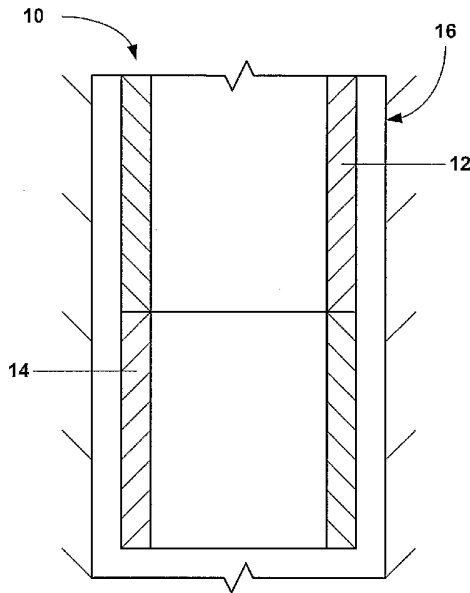

WO 2006/020809 A2



GM, KE, LS, MW, MZ, NA, SD, SL, SZ, TZ, UG, ZM, ZW), Eurasian (AM, AZ, BY, KG, KZ, MD, RU, TJ, TM), European (AT, BE, BG, CH, CY, CZ, DE, DK, EE, ES, FI, FR, GB, GR, HU, IE, IS, IT, LT, LU, LV, MC, NL, PL, PT, RO, SE, SI, SK, TR), OAPI (BF, BJ, CF, CG, CI, CM, GA, GN, GQ, GW, ML, MR, NE, SN, TD, TG).

Declaration under Rule 4.17:

— *of inventorship (Rule 4.17(iv)) for US only*

Published:

— *without international search report and to be republished upon receipt of that report*

For two-letter codes and other abbreviations, refer to the "Guidance Notes on Codes and Abbreviations" appearing at the beginning of each regular issue of the PCT Gazette.

EXPANDABLE TUBULAR MEMBER HAVING VARIABLE MATERIAL PROPERTIES

Cross Reference To Related Applications

[001] This application claims the benefit of the filing date of US provisional patent application serial number 60/600,679, attorney docket number 25791.194, filed on August 11, 2004, the disclosure which is incorporated herein by reference.

[002] This application is a continuation-in-part of one or more of the following: (1) PCT application US02/04353, filed on 2/14/02, attorney docket no. 25791.50.02, which claims priority from U.S. provisional patent application serial no. 60/270,007, attorney docket no. 25791.50, filed on 2/20/2001; (2) PCT application US 03/00609, filed on 1/9/03, attorney docket no. 25791.71.02, which claims priority from U.S. provisional patent application serial no. 60/357,372, attorney docket no. 25791.71, filed on 2/15/02; and (3) U.S. provisional patent application serial number 60/585,370, attorney docket number 25791.299, filed on 7/2/2004, the disclosures of which are incorporated herein by reference.

[003] This application is related to the following co-pending applications: (1) U.S. Patent Number 6,497,289, which was filed as U.S. Patent Application serial no. 09/454,139, attorney docket no. 25791.03.02, filed on 12/3/1999, which claims priority from provisional application 60/111,293, filed on 12/7/98, (2) U.S. patent application serial no. 09/510,913, attorney docket no. 25791.7.02, filed on 2/23/2000, which claims priority from provisional application 60/121,702, filed on 2/25/99, (3) U.S. patent application serial no. 09/502,350, attorney docket no. 25791.8.02, filed on 2/10/2000, which claims priority from provisional application 60/119,611, filed on 2/11/99, (4) U.S. patent no. 6,328,113, which was filed as U.S. Patent Application serial number 09/440,338, attorney docket number 25791.9.02, filed on 11/15/99, which claims priority from provisional application 60/108,558, filed on 11/16/98, (5) U.S. patent application serial no. 10/169,434, attorney docket no. 25791.10.04, filed on 7/1/02, which claims priority from provisional application 60/183,546, filed on 2/18/00, (6) U.S. patent application serial no. 09/523,468, attorney docket no. 25791.11.02, filed on 3/10/2000, which claims priority from provisional application 60/124,042, filed on 3/11/99, (7) U.S. patent number 6,568,471, which was filed as patent application serial no. 09/512,895, attorney docket no. 25791.12.02, filed on 2/24/2000, which claims priority from provisional application 60/121,841, filed on 2/26/99, (8) U.S. patent number 6,575,240, which was filed as patent application serial no. 09/511,941, attorney docket no. 25791.16.02, filed on 2/24/2000, which claims priority from provisional application 60/121,907, filed on 2/26/99, (9) U.S. patent number 6,557,640, which was filed as patent application serial no. 09/588,946, attorney docket no. 25791.17.02, filed on 6/7/2000, which claims priority from provisional

application 60/137,998, filed on 6/7/99, (10) U.S. patent application serial no. 09/981,916, attorney docket no. 25791.18, filed on 10/18/01 as a continuation-in-part application of U.S. patent no. 6,328,113, which was filed as U.S. Patent Application serial number 09/440,338, attorney docket number 25791.9.02, filed on 11/15/99, which claims priority from provisional application 60/108,558, filed on 11/16/98, (11) U.S. patent number 6,604,763, which was filed as application serial no. 09/559,122, attorney docket no. 25791.23.02, filed on 4/26/2000, which claims priority from provisional application 60/131,106, filed on 4/26/99, (12) U.S. patent application serial no. 10/030,593, attorney docket no. 25791.25.08, filed on 1/8/02, which claims priority from provisional application 60/146,203, filed on 7/29/99, (13) U.S. provisional patent application serial no. 60/143,039, attorney docket no. 25791.26, filed on 7/9/99, (14) U.S. patent application serial no. 10/111,982, attorney docket no. 25791.27.08, filed on 4/30/02, which claims priority from provisional patent application serial no. 60/162,671, attorney docket no. 25791.27, filed on 11/1/1999, (15) U.S. provisional patent application serial no. 60/154,047, attorney docket no. 25791.29, filed on 9/16/1999, (16) U.S. provisional patent application serial no. 60/438,828, attorney docket no. 25791.31, filed on 1/9/03, (17) U.S. patent number 6,564,875, which was filed as application serial no. 09/679,907, attorney docket no. 25791.34.02, on 10/5/00, which claims priority from provisional patent application serial no. 60/159,082, attorney docket no. 25791.34, filed on 10/12/1999, (18) U.S. patent application serial no. 10/089,419, filed on 3/27/02, attorney docket no. 25791.36.03, which claims priority from provisional patent application serial no. 60/159,039, attorney docket no. 25791.36, filed on 10/12/1999, (19) U.S. patent application serial no. 09/679,906, filed on 10/5/00, attorney docket no. 25791.37.02, which claims priority from provisional patent application serial no. 60/159,033, attorney docket no. 25791.37, filed on 10/12/1999, (20) U.S. patent application serial no. 10/303,992, filed on 11/22/02, attorney docket no. 25791.38.07, which claims priority from provisional patent application serial no. 60/212,359, attorney docket no. 25791.38, filed on 6/19/2000, (21) U.S. provisional patent application serial no. 60/165,228, attorney docket no. 25791.39, filed on 11/12/1999, (22) U.S. provisional patent application serial no. 60/455,051, attorney docket no. 25791.40, filed on 3/14/03, (23) PCT application US02/2477, filed on 6/26/02, attorney docket no. 25791.44.02, which claims priority from U.S. provisional patent application serial no. 60/303,711, attorney docket no. 25791.44, filed on 7/6/01, (24) U.S. patent application serial no. 10/311,412, filed on 12/12/02, attorney docket no. 25791.45.07, which claims priority from provisional patent application serial no. 60/221,443, attorney docket no. 25791.45, filed on 7/28/2000, (25) U.S. patent application serial no. 10/, filed on 12/18/02, attorney docket no. 25791.46.07, which claims priority from provisional patent application serial no. 60/221,645, attorney docket no. 25791.46, filed on 7/28/2000, (26) U.S. patent

application serial no. 10/322,947, filed on 1/22/03, attorney docket no. 25791.47.03, which claims priority from provisional patent application serial no. 60/233,638, attorney docket no. 25791.47, filed on 9/18/2000, (27) U.S. patent application serial no. 10/406,648, filed on 3/31/03, attorney docket no. 25791.48.06, which claims priority from provisional patent application serial no. 60/237,334, attorney docket no. 25791.48, filed on 10/2/2000, (28) PCT application US02/04353, filed on 2/14/02, attorney docket no. 25791.50.02, which claims priority from U.S. provisional patent application serial no. 60/270,007, attorney docket no. 25791.50, filed on 2/20/2001, (29) U.S. patent application serial no. 10/465,835, filed on 6/13/03, attorney docket no. 25791.51.06, which claims priority from provisional patent application serial no. 60/262,434, attorney docket no. 25791.51, filed on 1/17/2001, (30) U.S. patent application serial no. 10/465,831, filed on 6/13/03, attorney docket no. 25791.52.06, which claims priority from U.S. provisional patent application serial no. 60/259,486, attorney docket no. 25791.52, filed on 1/3/2001, (31) U.S. provisional patent application serial no. 60/452,303, filed on 3/5/03, attorney docket no. 25791.53, (32) U.S. patent number 6,470,966, which was filed as patent application serial number 09/850,093, filed on 5/7/01, attorney docket no. 25791.55, as a divisional application of U.S. Patent Number 6,497,289, which was filed as U.S. Patent Application serial no. 09/454,139, attorney docket no. 25791.03.02, filed on 12/3/1999, which claims priority from provisional application 60/111,293, filed on 12/7/98, (33) U.S. patent number 6,561,227, which was filed as patent application serial number 09/852,026, filed on 5/9/01, attorney docket no. 25791.56, as a divisional application of U.S. Patent Number 6,497,289, which was filed as U.S. Patent Application serial no. 09/454,139, attorney docket no. 25791.03.02, filed on 12/3/1999, which claims priority from provisional application 60/111,293, filed on 12/7/98, (34) U.S. patent application serial number 09/852,027, filed on 5/9/01, attorney docket no. 25791.57, as a divisional application of U.S. Patent Number 6,497,289, which was filed as U.S. Patent Application serial no. 09/454,139, attorney docket no. 25791.03.02, filed on 12/3/1999, which claims priority from provisional application 60/111,293, filed on 12/7/98, (35) PCT Application US02/25608, attorney docket no. 25791.58.02, filed on 8/13/02, which claims priority from provisional application 60/318,021, filed on 9/7/01, attorney docket no. 25791.58, (36) PCT Application US02/24399, attorney docket no. 25791.59.02, filed on 8/1/02, which claims priority from U.S. provisional patent application serial no. 60/313,453, attorney docket no. 25791.59, filed on 8/20/2001, (37) PCT Application US02/29856, attorney docket no. 25791.60.02, filed on 9/19/02, which claims priority from U.S. provisional patent application serial no. 60/326,886, attorney docket no. 25791.60, filed on 10/3/2001, (38) PCT Application US02/20256, attorney docket no. 25791.61.02, filed on 6/26/02, which claims priority from U.S. provisional patent application serial no. 60/303,740, attorney docket no.

25791.61, filed on 7/6/2001, (39) U.S. patent application serial no. 09/962,469, filed on 9/25/01, attorney docket no. 25791.62, which is a divisional of U.S. patent application serial no. 09/523,468, attorney docket no. 25791.11.02, filed on 3/10/2000, which claims priority from provisional application 60/124,042, filed on 3/11/99, (40) U.S. patent application serial no. 09/962,470, filed on 9/25/01, attorney docket no. 25791.63, which is a divisional of U.S. patent application serial no. 09/523,468, attorney docket no. 25791.11.02, filed on 3/10/2000, which claims priority from provisional application 60/124,042, filed on 3/11/99, (41) U.S. patent application serial no. 09/962,471, filed on 9/25/01, attorney docket no. 25791.64, which is a divisional of U.S. patent application serial no. 09/523,468, attorney docket no. 25791.11.02, filed on 3/10/2000, which claims priority from provisional application 60/124,042, filed on 3/11/99, (42) U.S. patent application serial no. 09/962,467, filed on 9/25/01, attorney docket no. 25791.65, which is a divisional of U.S. patent application serial no. 09/523,468, attorney docket no. 25791.11.02, filed on 3/10/2000, which claims priority from provisional application 60/124,042, filed on 3/11/99, (43) U.S. patent application serial no. 09/962,468, filed on 9/25/01, attorney docket no. 25791.66, which is a divisional of U.S. patent application serial no. 09/523,468, attorney docket no. 25791.11.02, filed on 3/10/2000, which claims priority from provisional application 60/124,042, filed on 3/11/99, (44) PCT application US 02/25727, filed on 8/14/02, attorney docket no. 25791.67.03, which claims priority from U.S. provisional patent application serial no. 60/317,985, attorney docket no. 25791.67, filed on 9/6/2001, and U.S. provisional patent application serial no. 60/318,386, attorney docket no. 25791.67.02, filed on 9/10/2001, (45) PCT application US 02/39425, filed on 12/10/02, attorney docket no. 25791.68.02, which claims priority from U.S. provisional patent application serial no. 60/343,674, attorney docket no. 25791.68, filed on 12/27/2001, (46) U.S. utility patent application serial no. 09/969,922, attorney docket no. 25791.69, filed on 10/3/2001, which is a continuation-in-part application of U.S. patent no. 6,328,113, which was filed as U.S. Patent Application serial number 09/440,338, attorney docket number 25791.9.02, filed on 11/15/99, which claims priority from provisional application 60/108,558, filed on 11/16/98, (47) U.S. utility patent application serial no. 10/516,467, attorney docket no. 25791.70, filed on 12/10/01, which is a continuation application of U.S. utility patent application serial no. 09/969,922, attorney docket no. 25791.69, filed on 10/3/2001, which is a continuation-in-part application of U.S. patent no. 6,328,113, which was filed as U.S. Patent Application serial number 09/440,338, attorney docket number 25791.9.02, filed on 11/15/99, which claims priority from provisional application 60/108,558, filed on 11/16/98, (48) PCT application US 03/00609, filed on 1/9/03, attorney docket no. 25791.71.02, which claims priority from U.S. provisional patent application serial no. 60/357,372, attorney docket no. 25791.71, filed on 2/15/02, (49) U.S.

patent application serial no. 10/074,703, attorney docket no. 25791.74, filed on 2/12/02, which is a divisional of U.S. patent number 6,568,471, which was filed as patent application serial no. 09/512,895, attorney docket no. 25791.12.02, filed on 2/24/2000, which claims priority from provisional application 60/121,841, filed on 2/26/99, (50) U.S. patent application serial no. 10/074,244, attorney docket no. 25791.75, filed on 2/12/02, which is a divisional of U.S. patent number 6,568,471, which was filed as patent application serial no. 09/512,895, attorney docket no. 25791.12.02, filed on 2/24/2000, which claims priority from provisional application 60/121,841, filed on 2/26/99, (51) U.S. patent application serial no. 10/076,660, attorney docket no. 25791.76, filed on 2/15/02, which is a divisional of U.S. patent number 6,568,471, which was filed as patent application serial no. 09/512,895, attorney docket no. 25791.12.02, filed on 2/24/2000, which claims priority from provisional application 60/121,841, filed on 2/26/99, (52) U.S. patent application serial no. 10/076,661, attorney docket no. 25791.77, filed on 2/15/02, which is a divisional of U.S. patent number 6,568,471, which was filed as patent application serial no. 09/512,895, attorney docket no. 25791.12.02, filed on 2/24/2000, which claims priority from provisional application 60/121,841, filed on 2/26/99, (53) U.S. patent application serial no. 10/076,659, attorney docket no. 25791.78, filed on 2/15/02, which is a divisional of U.S. patent number 6,568,471, which was filed as patent application serial no. 09/512,895, attorney docket no. 25791.12.02, filed on 2/24/2000, which claims priority from provisional application 60/121,841, filed on 2/26/99, (54) U.S. patent application serial no. 10/078,928, attorney docket no. 25791.79, filed on 2/20/02, which is a divisional of U.S. patent number 6,568,471, which was filed as patent application serial no. 09/512,895, attorney docket no. 25791.12.02, filed on 2/24/2000, which claims priority from provisional application 60/121,841, filed on 2/26/99, (55) U.S. patent application serial no. 10/078,922, attorney docket no. 25791.80, filed on 2/20/02, which is a divisional of U.S. patent number 6,568,471, which was filed as patent application serial no. 09/512,895, attorney docket no. 25791.12.02, filed on 2/24/2000, which claims priority from provisional application 60/121,841, filed on 2/26/99, (56) U.S. patent application serial no. 10/078,921, attorney docket no. 25791.81, filed on 2/20/02, which is a divisional of U.S. patent number 6,568,471, which was filed as patent application serial no. 09/512,895, attorney docket no. 25791.12.02, filed on 2/24/2000, which claims priority from provisional application 60/121,841, filed on 2/26/99, (57) U.S. patent application serial no. 10/261,928, attorney docket no. 25791.82, filed on 10/1/02, which is a divisional of U.S. patent number 6,557,640, which was filed as patent application serial no. 09/588,946, attorney docket no. 25791.17.02, filed on 6/7/2000, which claims priority from provisional application 60/137,998, filed on 6/7/99, (58) U.S. patent application serial no. 10/079,276 , attorney docket no.

25791.83, filed on 2/20/02, which is a divisional of U.S. patent number 6,568,471, which was filed as patent application serial no. 09/512,895, attorney docket no. 25791.12.02, filed on 2/24/2000, which claims priority from provisional application 60/121,841, filed on 2/26/99, (59) U.S. patent application serial no. 10/262,009, attorney docket no. 25791.84, filed on 10/1/02, which is a divisional of U.S. patent number 6,557,640, which was filed as patent application serial no. 09/588,946, attorney docket no. 25791.17.02, filed on 6/7/2000, which claims priority from provisional application 60/137,998, filed on 6/7/99, (60) U.S. patent application serial no. 10/092,481, attorney docket no. 25791.85, filed on 3/7/02, which is a divisional of U.S. patent number 6,568,471, which was filed as patent application serial no. 09/512,895, attorney docket no. 25791.12.02, filed on 2/24/2000, which claims priority from provisional application 60/121,841, filed on 2/26/99, (61) U.S. patent application serial no. 10/261,926, attorney docket no. 25791.86, filed on 10/1/02, which is a divisional of U.S. patent number 6,557,640, which was filed as patent application serial no. 09/588,946, attorney docket no. 25791.17.02, filed on 6/7/2000, which claims priority from provisional application 60/137,998, filed on 6/7/99, (62) PCT application US 02/36157, filed on 11/12/02, attorney docket no. 25791.87.02, which claims priority from U.S. provisional patent application serial no. 60/338,996, attorney docket no. 25791.87, filed on 11/12/01, (63) PCT application US 02/36267, filed on 11/12/02, attorney docket no. 25791.88.02, which claims priority from U.S. provisional patent application serial no. 60/339,013, attorney docket no. 25791.88, filed on 11/12/01, (64) PCT application US 03/11765, filed on 4/16/03, attorney docket no. 25791.89.02, which claims priority from U.S. provisional patent application serial no. 60/383,917, attorney docket no. 25791.89, filed on 5/29/02, (65) PCT application US 03/15020, filed on 5/12/03, attorney docket no. 25791.90.02, which claims priority from U.S. provisional patent application serial no. 60/391,703, attorney docket no. 25791.90, filed on 6/26/02, (66) PCT application US 02/39418, filed on 12/10/02, attorney docket no. 25791.92.02, which claims priority from U.S. provisional patent application serial no. 60/346,309, attorney docket no. 25791.92, filed on 1/7/02, (67) PCT application US 03/06544, filed on 3/4/03, attorney docket no. 25791.93.02, which claims priority from U.S. provisional patent application serial no. 60/372,048, attorney docket no. 25791.93, filed on 4/12/02, (68) U.S. patent application serial no. 10/331,718, attorney docket no. 25791.94, filed on 12/30/02, which is a divisional U.S. patent application serial no. 09/679,906, filed on 10/5/00, attorney docket no. 25791.37.02, which claims priority from provisional patent application serial no. 60/159,033, attorney docket no. 25791.37, filed on 10/12/1999, (69) PCT application US 03/04837, filed on 2/29/03, attorney docket no. 25791.95.02, which claims priority from U.S. provisional patent application serial no. 60/363,829, attorney docket no. 25791.95, filed on 3/13/02, (70) U.S. patent application serial no. 10/261,927,

attorney docket no. 25791.97, filed on 10/1/02, which is a divisional of U.S. patent number 6,557,640, which was filed as patent application serial no. 09/588,946, attorney docket no. 25791.17.02, filed on 6/7/2000, which claims priority from provisional application 60/137,998, filed on 6/7/99, (71) U.S. patent application serial no. 10/262,008, attorney docket no. 25791.98, filed on 10/1/02, which is a divisional of U.S. patent number 6,557,640, which was filed as patent application serial no. 09/588,946, attorney docket no. 25791.17.02, filed on 6/7/2000, which claims priority from provisional application 60/137,998, filed on 6/7/99, (72) U.S. patent application serial no. 10/261,925, attorney docket no. 25791.99, filed on 10/1/02, which is a divisional of U.S. patent number 6,557,640, which was filed as patent application serial no. 09/588,946, attorney docket no. 25791.17.02, filed on 6/7/2000, which claims priority from provisional application 60/137,998, filed on 6/7/99, (73) U.S. patent application serial no. 10/199,524, attorney docket no. 25791.100, filed on 7/19/02, which is a continuation of U.S. Patent Number 6,497,289, which was filed as U.S. Patent Application serial no. 09/454,139, attorney docket no. 25791.03.02, filed on 12/3/1999, which claims priority from provisional application 60/111,293, filed on 12/7/98, (74) PCT application US 03/10144, filed on 3/28/03, attorney docket no. 25791.101.02, which claims priority from U.S. provisional patent application serial no. 60/372,632, attorney docket no. 25791.101, filed on 4/15/02, (75) U.S. provisional patent application serial no. 60/412,542, attorney docket no. 25791.102, filed on 9/20/02, (76) PCT application US 03/14153, filed on 5/6/03, attorney docket no. 25791.104.02, which claims priority from U.S. provisional patent application serial no. 60/380,147, attorney docket no. 25791.104, filed on 5/6/02, (77) PCT application US 03/19993, filed on 6/24/03, attorney docket no. 25791.106.02, which claims priority from U.S. provisional patent application serial no. 60/397,284, attorney docket no. 25791.106, filed on 7/19/02, (78) PCT application US 03/13787, filed on 5/5/03, attorney docket no. 25791.107.02, which claims priority from U.S. provisional patent application serial no. 60/387,486, attorney docket no. 25791.107, filed on 6/10/02, (79) PCT application US 03/18530, filed on 6/11/03, attorney docket no. 25791.108.02, which claims priority from U.S. provisional patent application serial no. 60/387,961, attorney docket no. 25791.108, filed on 6/12/02, (80) PCT application US 03/20694, filed on 7/1/03, attorney docket no. 25791.110.02, which claims priority from U.S. provisional patent application serial no. 60/398,061, attorney docket no. 25791.110, filed on 7/24/02, (81) PCT application US 03/20870, filed on 7/2/03, attorney docket no. 25791.111.02, which claims priority from U.S. provisional patent application serial no. 60/399,240, attorney docket no. 25791.111, filed on 7/29/02, (82) U.S. provisional patent application serial no. 60/412,487, attorney docket no. 25791.112, filed on 9/20/02, (83) U.S. provisional patent application serial no. 60/412,488, attorney docket no. 25791.114, filed on 9/20/02, (84) U.S. patent application serial no.

10/280,356, attorney docket no. 25791.115, filed on 10/25/02, which is a continuation of U.S. patent number 6,470,966, which was filed as patent application serial number 09/850,093, filed on 5/7/01, attorney docket no. 25791.55, as a divisional application of U.S. Patent Number 6,497,289, which was filed as U.S. Patent Application serial no. 09/454,139, attorney docket no. 25791.03.02, filed on 12/3/1999, which claims priority from provisional application 60/111,293, filed on 12/7/98, (85) U.S. provisional patent application serial no. 60/412,177, attorney docket no. 25791.117, filed on 9/20/02, (86) U.S. provisional patent application serial no. 60/412,653, attorney docket no. 25791.118, filed on 9/20/02, (87) U.S. provisional patent application serial no. 60/405,610, attorney docket no. 25791.119, filed on 8/23/02, (88) U.S. provisional patent application serial no. 60/405,394, attorney docket no. 25791.120, filed on 8/23/02, (89) U.S. provisional patent application serial no. 60/412,544, attorney docket no. 25791.121, filed on 9/20/02, (90) PCT application US 03/24779, filed on 8/8/03, attorney docket no. 25791.125.02, which claims priority from U.S. provisional patent application serial no. 60/407,442, attorney docket no. 25791.125, filed on 8/30/02, (91) U.S. provisional patent application serial no. 60/423,363, attorney docket no. 25791.126, filed on 12/10/02, (92) U.S. provisional patent application serial no. 60/412,196, attorney docket no. 25791.127, filed on 9/20/02, (93) U.S. provisional patent application serial no. 60/412,187, attorney docket no. 25791.128, filed on 9/20/02, (94) U.S. provisional patent application serial no. 60/412,371, attorney docket no. 25791.129, filed on 9/20/02, (95) U.S. patent application serial no. 10/382,325, attorney docket no. 25791.145, filed on 3/5/03, which is a continuation of U.S. patent number 6,557,640, which was filed as patent application serial no. 09/588,946, attorney docket no. 25791.17.02, filed on 6/7/2000, which claims priority from provisional application 60/137,998, filed on 6/7/99, (96) U.S. patent application serial no. 10/624,842, attorney docket no. 25791.151, filed on 7/22/03, which is a divisional of U.S. patent application serial no. 09/502,350, attorney docket no. 25791.8.02, filed on 2/10/2000, which claims priority from provisional application 60/119,611, filed on 2/11/99, (97) U.S. provisional patent application serial no. 60/431,184, attorney docket no. 25791.157, filed on 12/5/02, (98) U.S. provisional patent application serial no. 60/448,526, attorney docket no. 25791.185, filed on 2/18/03, (99) U.S. provisional patent application serial no. 60/461,539, attorney docket no. 25791.186, filed on 4/9/03, (100) U.S. provisional patent application serial no. 60/462,750, attorney docket no. 25791.193, filed on 4/14/03, (101) U.S. provisional patent application serial no. 60/436,106, attorney docket no. 25791.200, filed on 12/23/02, (102) U.S. provisional patent application serial no. 60/442,942, attorney docket no. 25791.213, filed on 1/27/03, (103) U.S. provisional patent application serial no. 60/442,938, attorney docket no. 25791.225, filed on 1/27/03, (104) U.S. provisional patent application serial no. 60/418,687, attorney docket no. 25791.228, filed on 4/18/03,

(105) U.S. provisional patent application serial no. 60/454,896, attorney docket no. 25791.236, filed on 3/14/03, (106) U.S. provisional patent application serial no. 60/450,504, attorney docket no. 25791.238, filed on 2/26/03, (107) U.S. provisional patent application serial no. 60/451,152, attorney docket no. 25791.239, filed on 3/9/03, (108) U.S. provisional patent application serial no. 60/455,124, attorney docket no. 25791.241, filed on 3/17/03, (109) U.S. provisional patent application serial no. 60/453,678, attorney docket no. 25791.253, filed on 3/11/03, (110) U.S. patent application serial no. 10/421,682, attorney docket no. 25791.256, filed on 4/23/03, which is a continuation of U.S. patent application serial no. 09/523,468, attorney docket no. 25791.11.02, filed on 3/10/2000, which claims priority from provisional application 60/124,042, filed on 3/11/99, (111) U.S. provisional patent application serial no. 60/457,965, attorney docket no. 25791.260, filed on 3/27/03, (112) U.S. provisional patent application serial no. 60/455,718, attorney docket no. 25791.262, filed on 3/18/03, (113) U.S. patent number 6,550,821, which was filed as patent application serial no. 09/811,734, filed on 3/19/01, (114) U.S. patent application serial no. 10/436,467, attorney docket no. 25791.268, filed on 5/12/03, which is a continuation of U.S. patent number 6,604,763, which was filed as application serial no. 09/559,122, attorney docket no. 25791.23.02, filed on 4/26/2000, which claims priority from provisional application 60/131,106, filed on 4/26/99, (115) U.S. provisional patent application serial no. 60/459,776, attorney docket no. 25791.270, filed on 4/2/03, (116) U.S. provisional patent application serial no. 60/461,094, attorney docket no. 25791.272, filed on 4/8/03, (117) U.S. provisional patent application serial no. 60/461,038, attorney docket no. 25791.273, filed on 4/7/03, (118) U.S. provisional patent application serial no. 60/463,586, attorney docket no. 25791.277, filed on 4/17/03, (119) U.S. provisional patent application serial no. 60/472,240, attorney docket no. 25791.286, filed on 5/20/03, (120) U.S. patent application serial no. 10/619,285, attorney docket no. 25791.292, filed on 7/14/03, which is a continuation-in-part of U.S. utility patent application serial no. 09/969,922, attorney docket no. 25791.69, filed on 10/3/2001, which is a continuation-in-part application of U.S. patent no. 6,328,113, which was filed as U.S. Patent Application serial number 09/440,338, attorney docket number 25791.9.02, filed on 11/15/99, which claims priority from provisional application 60/108,558, filed on 11/16/98, (121) U.S. utility patent application serial no. 10/418,688, attorney docket no. 25791.257, which was filed on 4/18/03, as a division of U.S. utility patent application serial no. 09/523,468, attorney docket no. 25791.11.02, filed on 3/10/2000, which claims priority from provisional application 60/124,042, filed on 3/11/99, (122) PCT patent application serial no. PCT/US04/06246, attorney docket no. 25791.238.02, filed on 2/26/2004, (123) PCT patent application serial number PCT/US04/08170, attorney docket number 25791.40.02, filed on 3/15/04, (124) PCT patent application serial number

PCT/US04/08171, attorney docket number 25791.236.02, filed on 3/15/04, (125) PCT patent application serial number PCT/US04/08073, attorney docket number 25791.262.02, filed on 3/18/04, (126) PCT patent application serial number PCT/US04/07711, attorney docket number 25791.253.02, filed on 3/11/2004, (127) PCT patent application serial number PCT/US2004/009434, attorney docket number 25791.260.02, filed on 3/26/2004, (128) PCT patent application serial number PCT/US2004/010317, attorney docket number 25791.270.02, filed on 4/2/2004, (129) PCT patent application serial number PCT/US2004/010712, attorney docket number 25791.272.02, filed on 4/6/2004, (130) PCT patent application serial number PCT/US2004/010762, attorney docket number 25791.273.02, filed on 4/6/2004, (131) PCT patent application serial number PCT/2004/011973, attorney docket number 25791.277.02, filed on 4/15/2004, (132) U.S. provisional patent application serial number 60/495,056, attorney docket number 25791.301, filed on 8/14/2003, and (133) U.S. provisional patent application serial number 60/585,370, attorney docket number 25791.299, filed on 7/2/2004, the disclosures of which are incorporated herein by reference.

Background of the Invention

[004] This invention relates generally to oil and gas exploration, and in particular to forming and repairing wellbore casings to facilitate oil and gas exploration.

Summary Of The Invention

[005] According to another aspect of the present invention, an expandable tubular member is provided that includes a steel alloy including: 0.065 % C, 1.44 % Mn, 0.01 % P, 0.002 % S, 0.24 % Si, 0.01 % Cu, 0.01 % Ni, and 0.02 % Cr.

[006] According to another aspect of the present invention, an expandable tubular member is provided that includes a steel alloy including: 0.18 % C, 1.28 % Mn, 0.017 % P, 0.004 % S, 0.29 % Si, 0.01 % Cu, 0.01 % Ni, and 0.03 % Cr.

[007] According to another aspect of the present invention, an expandable tubular member is provided that includes a steel alloy including: 0.08 % C, 0.82 % Mn, 0.006 % P, 0.003 % S, 0.30 % Si, 0.16 % Cu, 0.05 % Ni, and 0.05 % Cr.

[008] According to another aspect of the present invention, an expandable tubular member is provided that includes a steel alloy including: 0.02 % C, 1.31 % Mn, 0.02 % P, 0.001 % S, 0.45 % Si, 9.1 % Ni, and 18.7 % Cr.

[009] According to another aspect of the present invention, an expandable tubular member is provided, wherein the yield point of the expandable tubular member is at most about 46.9 ksi prior to a radial expansion and plastic deformation; and wherein the yield point of the expandable tubular member is at least about 65.9 ksi after the radial expansion and plastic deformation.

[0010] According to another aspect of the present invention, an expandable tubular member is provided, wherein a yield point of the expandable tubular member after a radial expansion and plastic deformation is at least about 40 % greater than the yield point of the expandable tubular member prior to the radial expansion and plastic deformation.

[0011] According to another aspect of the present invention, an expandable tubular member is provided, wherein the anisotropy of the expandable tubular member, prior to the radial expansion and plastic deformation, is at least about 1.48.

[0012] According to another aspect of the present invention, an expandable tubular member is provided, wherein the yield point of the expandable tubular member is at most about 57.8 ksi prior to the radial expansion and plastic deformation; and wherein the yield point of the expandable tubular member is at least about 74.4 ksi after the radial expansion and plastic deformation.

[0013] According to another aspect of the present invention, an expandable tubular member is provided, wherein the yield point of the expandable tubular member after a radial expansion and plastic deformation is at least about 28 % greater than the yield point of the expandable tubular member prior to the radial expansion and plastic deformation.

[0014] According to another aspect of the present invention, an expandable tubular member is provided, wherein the anisotropy of the expandable tubular member, prior to the radial expansion and plastic deformation, is at least about 1.04.

[0015] According to another aspect of the present invention, an expandable tubular member is provided, wherein the anisotropy of the expandable tubular member, prior to the radial expansion and plastic deformation, is at least about 1.92.

[0016] According to another aspect of the present invention, an expandable tubular member is provided, wherein the anisotropy of the expandable tubular member, prior to the radial expansion and plastic deformation, is at least about 1.34.

[0017] According to another aspect of the present invention, an expandable tubular member is provided, wherein the anisotropy of the expandable tubular member, prior to the radial expansion and plastic deformation, ranges from about 1.04 to about 1.92.

[0018] According to another aspect of the present invention, an expandable tubular member is provided, wherein the yield point of the expandable tubular member, prior to the radial expansion and plastic deformation, ranges from about 47.6 ksi to about 61.7 ksi.

[0019] According to another aspect of the present invention, an expandable tubular member is provided, wherein the expandability coefficient of the expandable tubular member, prior to the radial expansion and plastic deformation, is greater than 0.12.

[0020] According to another aspect of the present invention, an expandable tubular member is provided, wherein the expandability coefficient of the expandable tubular member is

greater than the expandability coefficient of another portion of the expandable tubular member.

[0021] According to another aspect of the present invention, an expandable tubular member is provided, wherein the tubular member has a higher ductility and a lower yield point prior to a radial expansion and plastic deformation than after the radial expansion and plastic deformation.

[0022] According to another aspect of the present invention, an expandable tubular member is provided that includes a tubular body; wherein a yield point of an inner tubular portion of the tubular body is less than a yield point of an outer tubular portion of the tubular body.

Brief Description of the Drawings

[0023] Fig. 1 is a fragmentary cross sectional view of an exemplary embodiment of an expandable tubular member positioned within a preexisting structure.

[0024] Fig. 2 is a fragmentary cross sectional view of the expandable tubular member of Fig. 1 after positioning an expansion device within the expandable tubular member.

[0025] Fig. 3 is a fragmentary cross sectional view of the expandable tubular member of Fig. 2 after operating the expansion device within the expandable tubular member to radially expand and plastically deform a portion of the expandable tubular member.

[0026] Fig. 4 is a fragmentary cross sectional view of the expandable tubular member of Fig. 3 after operating the expansion device within the expandable tubular member to radially expand and plastically deform another portion of the expandable tubular member.

[0027] Fig. 5 is a graphical illustration of exemplary embodiments of the stress/strain curves for several portions of the expandable tubular member of Figs. 1-4.

[0028] Fig. 6 is a graphical illustration of the an exemplary embodiment of the yield strength vs. ductility curve for at least a portion of the expandable tubular member of Figs. 1-4.

[0029] Fig. 7 is a fragmentary cross sectional illustration of an embodiment of a series of overlapping expandable tubular members.

[0030] Fig. 8 is a fragmentary cross sectional view of an exemplary embodiment of an expandable tubular member positioned within a preexisting structure.

[0031] Fig. 9 is a fragmentary cross sectional view of the expandable tubular member of Fig. 8 after positioning an expansion device within the expandable tubular member.

[0032] Fig. 10 is a fragmentary cross sectional view of the expandable tubular member of Fig. 9 after operating the expansion device within the expandable tubular member to radially expand and plastically deform a portion of the expandable tubular member.

[0033] Fig. 11 is a fragmentary cross sectional view of the expandable tubular member of Fig. 10 after operating the expansion device within the expandable tubular member to radially expand and plastically deform another portion of the expandable tubular member.

[0034] Fig. 12 is a graphical illustration of exemplary embodiments of the stress/strain curves for several portions of the expandable tubular member of Figs. 8-11.

[0035] Fig. 13 is a graphical illustration of an exemplary embodiment of the yield strength vs. ductility curve for at least a portion of the expandable tubular member of Figs. 8-11.

[0036] Fig. 14 is a fragmentary cross sectional view of an exemplary embodiment of an expandable tubular member positioned within a preexisting structure.

[0037] Fig. 15 is a fragmentary cross sectional view of the expandable tubular member of Fig. 14 after positioning an expansion device within the expandable tubular member.

[0038] Fig. 16 is a fragmentary cross sectional view of the expandable tubular member of Fig. 15 after operating the expansion device within the expandable tubular member to radially expand and plastically deform a portion of the expandable tubular member.

[0039] Fig. 17 is a fragmentary cross sectional view of the expandable tubular member of Fig. 16 after operating the expansion device within the expandable tubular member to radially expand and plastically deform another portion of the expandable tubular member.

[0040] Fig. 18 is a flow chart illustration of an exemplary embodiment of a method of processing an expandable tubular member.

[0041] Fig. 19 is a graphical illustration of the an exemplary embodiment of the yield strength vs. ductility curve for at least a portion of the expandable tubular member during the operation of the method of Fig. 18.

[0042] Fig. 20 is a graphical illustration of stress/strain curves for an exemplary embodiment of an expandable tubular member.

[0043] Fig. 21 is a graphical illustration of stress/strain curves for an exemplary embodiment of an expandable tubular member.

[0044] Fig. 35a is a fragmentary cross-sectional illustration of an exemplary embodiment of an expandable tubular member.

[0045] Fig. 35b is a graphical illustration of an exemplary embodiment of the variation in the yield point for the expandable tubular member of Fig. 35a.

[0046] Fig. 36a is a flow chart illustration of an exemplary embodiment of a method for processing a tubular member.

[0047] Fig. 36b is an illustration of the microstructure of an exemplary embodiment of a tubular member prior to thermal processing.

[0048] Fig. 36c is an illustration of the microstructure of an exemplary embodiment of a tubular member after thermal processing.

[0049] Fig. 37a is a flow chart illustration of an exemplary embodiment of a method for processing a tubular member.

[0050] Fig. 37b is an illustration of the microstructure of an exemplary embodiment of a tubular member prior to thermal processing.

[0051] Fig. 37c is an illustration of the microstructure of an exemplary embodiment of a tubular member after thermal processing.

[0052] Fig. 38a is a flow chart illustration of an exemplary embodiment of a method for processing a tubular member.

[0053] Fig. 38b is an illustration of the microstructure of an exemplary embodiment of a tubular member prior to thermal processing.

[0054] Fig. 38c is an illustration of the microstructure of an exemplary embodiment of a tubular member after thermal processing.

Detailed Description of the Illustrative Embodiments

[0055] Referring initially to Fig. 1, an exemplary embodiment of an expandable tubular assembly 10 includes a first expandable tubular member 12 coupled to a second expandable tubular member 14. In several exemplary embodiments, the ends of the first and second expandable tubular members, 12 and 14, are coupled using, for example, a conventional mechanical coupling, a welded connection, a brazed connection, a threaded connection, and/or an interference fit connection. In an exemplary embodiment, the first expandable tubular member 12 has a plastic yield point YP_1 , and the second expandable tubular member 14 has a plastic yield point YP_2 . In an exemplary embodiment, the expandable tubular assembly 10 is positioned within a preexisting structure such as, for example, a wellbore 16 that traverses a subterranean formation 18.

[0056] As illustrated in Fig. 2, an expansion device 20 may then be positioned within the second expandable tubular member 14. In several exemplary embodiments, the expansion device 20 may include, for example, one or more of the following conventional expansion devices: a) an expansion cone; b) a rotary expansion device; c) a hydroforming expansion device; d) an impulsive force expansion device; d) any one of the expansion devices commercially available from, or disclosed in any of the published patent applications or issued patents, of Weatherford International, Baker Hughes, Halliburton Energy Services, Shell Oil Co., Schlumberger; and/or Enventure Global Technology L.L.C. In several exemplary embodiments, the expansion device 20 is positioned within the second expandable tubular member 14 before, during, or after the placement of the expandable tubular assembly 10 within the preexisting structure 16.

[0057] As illustrated in Fig. 3, the expansion device 20 may then be operated to radially expand and plastically deform at least a portion of the second expandable tubular member 14 to form a bell-shaped section.

[0058] As illustrated in Fig. 4, the expansion device 20 may then be operated to radially

expand and plastically deform the remaining portion of the second expandable tubular member 14 and at least a portion of the first expandable tubular member 12.

[0059] In an exemplary embodiment, at least a portion of at least a portion of at least one of the first and second expandable tubular members, 12 and 14, are radially expanded into intimate contact with the interior surface of the preexisting structure 16.

[0060] In an exemplary embodiment, as illustrated in Fig. 5, the plastic yield point YP_1 is greater than the plastic yield point YP_2 . In this manner, in an exemplary embodiment, the amount of power and/or energy required to radially expand the second expandable tubular member 14 is less than the amount of power and/or energy required to radially expand the first expandable tubular member 12.

[0061] In an exemplary embodiment, as illustrated in Fig. 6, the first expandable tubular member 12 and/or the second expandable tubular member 14 have a ductility D_{PE} and a yield strength YS_{PE} prior to radial expansion and plastic deformation, and a ductility D_{AE} and a yield strength YS_{AE} after radial expansion and plastic deformation. In an exemplary embodiment, D_{PE} is greater than D_{AE} , and YS_{AE} is greater than YS_{PE} . In this manner, the first expandable tubular member 12 and/or the second expandable tubular member 14 are transformed during the radial expansion and plastic deformation process. Furthermore, in this manner, in an exemplary embodiment, the amount of power and/or energy required to radially expand each unit length of the first and/or second expandable tubular members, 12 and 14, is reduced. Furthermore, because the YS_{AE} is greater than YS_{PE} , the collapse strength of the first expandable tubular member 12 and/or the second expandable tubular member 14 is increased after the radial expansion and plastic deformation process.

[0062] In an exemplary embodiment, as illustrated in Fig. 7, following the completion of the radial expansion and plastic deformation of the expandable tubular assembly 10 described above with reference to Figs. 1-4, at least a portion of the second expandable tubular member 14 has an inside diameter that is greater than at least the inside diameter of the first expandable tubular member 12. In this manner a bell-shaped section is formed using at least a portion of the second expandable tubular member 14. Another expandable tubular assembly 22 that includes a first expandable tubular member 24 and a second expandable tubular member 26 may then be positioned in overlapping relation to the first expandable tubular assembly 10 and radially expanded and plastically deformed using the methods described above with reference to Figs. 1-4. Furthermore, following the completion of the radial expansion and plastic deformation of the expandable tubular assembly 20, in an exemplary embodiment, at least a portion of the second expandable tubular member 26 has an inside diameter that is greater than at least the inside diameter of the first expandable tubular member 24. In this manner a bell-shaped section is formed using at least a portion

of the second expandable tubular member 26. Furthermore, in this manner, a mono-diameter tubular assembly is formed that defines an internal passage 28 having a substantially constant cross-sectional area and/or inside diameter.

[0063] Referring to Fig. 8, an exemplary embodiment of an expandable tubular assembly 100 includes a first expandable tubular member 102 coupled to a tubular coupling 104. The tubular coupling 104 is coupled to a tubular coupling 106. The tubular coupling 106 is coupled to a second expandable tubular member 108. In several exemplary embodiments, the tubular couplings, 104 and 106, provide a tubular coupling assembly for coupling the first and second expandable tubular members, 102 and 108, together that may include, for example, a conventional mechanical coupling, a welded connection, a brazed connection, a threaded connection, and/or an interference fit connection. In an exemplary embodiment, the first and second expandable tubular members 12 have a plastic yield point YP_1 , and the tubular couplings, 104 and 106, have a plastic yield point YP_2 . In an exemplary embodiment, the expandable tubular assembly 100 is positioned within a preexisting structure such as, for example, a wellbore 110 that traverses a subterranean formation 112.

[0064] As illustrated in Fig. 9, an expansion device 114 may then be positioned within the second expandable tubular member 108. In several exemplary embodiments, the expansion device 114 may include, for example, one or more of the following conventional expansion devices: a) an expansion cone; b) a rotary expansion device; c) a hydroforming expansion device; d) an impulsive force expansion device; d) any one of the expansion devices commercially available from, or disclosed in any of the published patent applications or issued patents, of Weatherford International, Baker Hughes, Halliburton Energy Services, Shell Oil Co., Schlumberger, and/or Enventure Global Technology L.L.C. In several exemplary embodiments, the expansion device 114 is positioned within the second expandable tubular member 108 before, during, or after the placement of the expandable tubular assembly 100 within the preexisting structure 110.

[0065] As illustrated in Fig. 10, the expansion device 114 may then be operated to radially expand and plastically deform at least a portion of the second expandable tubular member 108 to form a bell-shaped section.

[0066] As illustrated in Fig. 11, the expansion device 114 may then be operated to radially expand and plastically deform the remaining portion of the second expandable tubular member 108, the tubular couplings, 104 and 106, and at least a portion of the first expandable tubular member 102.

[0067] In an exemplary embodiment, at least a portion of at least a portion of at least one of the first and second expandable tubular members, 102 and 108, are radially expanded into intimate contact with the interior surface of the preexisting structure 110.

[0068] In an exemplary embodiment, as illustrated in Fig. 12, the plastic yield point YP_1 is less than the plastic yield point YP_2 . In this manner, in an exemplary embodiment, the amount of power and/or energy required to radially expand each unit length of the first and second expandable tubular members, 102 and 108, is less than the amount of power and/or energy required to radially expand each unit length of the tubular couplings, 104 and 106.

[0069] In an exemplary embodiment, as illustrated in Fig. 13, the first expandable tubular member 12 and/or the second expandable tubular member 14 have a ductility D_{PE} and a yield strength YS_{PE} prior to radial expansion and plastic deformation, and a ductility D_{AE} and a yield strength YS_{AE} after radial expansion and plastic deformation. In an exemplary embodiment, D_{PE} is greater than D_{AE} , and YS_{AE} is greater than YS_{PE} . In this manner, the first expandable tubular member 12 and/or the second expandable tubular member 14 are transformed during the radial expansion and plastic deformation process. Furthermore, in this manner, in an exemplary embodiment, the amount of power and/or energy required to radially expand each unit length of the first and/or second expandable tubular members, 12 and 14, is reduced. Furthermore, because the YS_{AE} is greater than YS_{PE} , the collapse strength of the first expandable tubular member 12 and/or the second expandable tubular member 14 is increased after the radial expansion and plastic deformation process.

[0070] Referring to Fig. 14, an exemplary embodiment of an expandable tubular assembly 200 includes a first expandable tubular member 202 coupled to a second expandable tubular member 204 that defines radial openings 204a, 204b, 204c, and 204d. In several exemplary embodiments, the ends of the first and second expandable tubular members, 202 and 204, are coupled using, for example, a conventional mechanical coupling, a welded connection, a brazed connection, a threaded connection, and/or an interference fit connection. In an exemplary embodiment, one or more of the radial openings, 204a, 204b, 204c, and 204d, have circular, oval, square, and/or irregular cross sections and/or include portions that extend to and interrupt either end of the second expandable tubular member 204. In an exemplary embodiment, the expandable tubular assembly 200 is positioned within a preexisting structure such as, for example, a wellbore 206 that traverses a subterranean formation 208.

[0071] As illustrated in Fig. 15, an expansion device 210 may then be positioned within the second expandable tubular member 204. In several exemplary embodiments, the expansion device 210 may include, for example, one or more of the following conventional expansion devices: a) an expansion cone; b) a rotary expansion device; c) a hydroforming expansion device; d) an impulsive force expansion device; d) any one of the expansion devices commercially available from, or disclosed in any of the published patent applications or issued patents, of Weatherford International, Baker Hughes, Halliburton Energy Services,

Shell Oil Co., Schlumberger, and/or Enventure Global Technology L.L.C. In several exemplary embodiments, the expansion device 210 is positioned within the second expandable tubular member 204 before, during, or after the placement of the expandable tubular assembly 200 within the preexisting structure 206.

[0072] As illustrated in Fig. 16, the expansion device 210 may then be operated to radially expand and plastically deform at least a portion of the second expandable tubular member 204 to form a bell-shaped section.

[0073] As illustrated in Fig. 16, the expansion device 20 may then be operated to radially expand and plastically deform the remaining portion of the second expandable tubular member 204 and at least a portion of the first expandable tubular member 202.

[0074] In an exemplary embodiment, the anisotropy ratio AR for the first and second expandable tubular members is defined by the following equation:

$$AR = \ln (WT_f/WT_o) / \ln (D_f/D_o);$$

where AR = anisotropy ratio;

where WT_f = final wall thickness of the expandable tubular member following the radial expansion and plastic deformation of the expandable tubular member;

where WT_i = initial wall thickness of the expandable tubular member prior to the radial expansion and plastic deformation of the expandable tubular member;

where D_f = final inside diameter of the expandable tubular member following the radial expansion and plastic deformation of the expandable tubular member; and

where D_i = initial inside diameter of the expandable tubular member prior to the radial expansion and plastic deformation of the expandable tubular member.

[0075] In an exemplary embodiment, the anisotropy ratio AR for the first and/or second expandable tubular members, 202 and 204, is greater than 1.

[0076] In an exemplary experimental embodiment, the second expandable tubular member 204 had an anisotropy ratio AR greater than 1, and the radial expansion and plastic deformation of the second expandable tubular member did not result in any of the openings, 204a, 204b, 204c, and 204d, splitting or otherwise fracturing the remaining portions of the second expandable tubular member. This was an unexpected result.

[0077] Referring to Fig. 18, in an exemplary embodiment, one or more of the expandable tubular members, 12, 14, 24, 26, 102, 104, 106, 108, 202 and/or 204 are processed using a method 300 in which a tubular member in an initial state is thermo-mechanically processed in step 302. In an exemplary embodiment, the thermo-mechanical processing 302 includes one or more heat treating and/or mechanical forming processes. As a result, of the thermo-mechanical processing 302, the tubular member is transformed to an intermediate state. The tubular member is then further thermo-mechanically processed in step 304. In an

exemplary embodiment, the thermo-mechanical processing 304 includes one or more heat treating and/or mechanical forming processes. As a result, of the thermo-mechanical processing 304, the tubular member is transformed to a final state.

[0078] In an exemplary embodiment, as illustrated in Fig. 19, during the operation of the method 300, the tubular member has a ductility D_{PE} and a yield strength YS_{PE} prior to the final thermo-mechanical processing in step 304, and a ductility D_{AE} and a yield strength YS_{AE} after final thermo-mechanical processing. In an exemplary embodiment, D_{PE} is greater than D_{AE} , and YS_{AE} is greater than YS_{PE} . In this manner, the amount of energy and/or power required to transform the tubular member, using mechanical forming processes, during the final thermo-mechanical processing in step 304 is reduced. Furthermore, in this manner, because the YS_{AE} is greater than YS_{PE} , the collapse strength of the tubular member is increased after the final thermo-mechanical processing in step 304.

[0079] In an exemplary embodiment, one or more of the expandable tubular members, 12, 14, 24, 26, 102, 104, 106, 108, 202 and/or 204, have the following characteristics:

Characteristic	Value
Tensile Strength	60 to 120 ksi
Yield Strength	50 to 100 ksi
Y/T Ratio	Maximum of 50/85 %
Elongation During Radial Expansion and Plastic Deformation	Minimum of 35 %
Width Reduction During Radial Expansion and Plastic Deformation	Minimum of 40 %
Wall Thickness Reduction During Radial Expansion and Plastic Deformation	Minimum of 30 %
Anisotropy	Minimum of 1.5
Minimum Absorbed Energy at -4 F (-20 C) in the Longitudinal Direction	80 ft-lb
Minimum Absorbed Energy at -4 F (-20 C) in the Transverse Direction	60 ft-lb

Characteristic	Value
Minimum Absorbed Energy at -4 F (-20 C) Transverse To A Weld Area	60 ft-lb
Flare Expansion Testing	Minimum of 75% Without A Failure
Increase in Yield Strength Due To Radial Expansion and Plastic Deformation	Greater than 5.4 %

[0080] In an exemplary embodiment, one or more of the expandable tubular members, 12, 14, 24, 26, 102, 104, 106, 108, 202 and/or 204, are characterized by an expandability coefficient f :

- i. $f = r \times n$
- ii. where f = expandability coefficient;
 1. r = anisotropy coefficient; and
 2. n = strain hardening exponent.

[0081] In an exemplary embodiment, the anisotropy coefficient for one or more of the expandable tubular members, 12, 14, 24, 26, 102, 104, 106, 108, 202 and/or 204 is greater than 1. In an exemplary embodiment, the strain hardening exponent for one or more of the expandable tubular members, 12, 14, 24, 26, 102, 104, 106, 108, 202 and/or 204 is greater than 0.12. In an exemplary embodiment, the expandability coefficient for one or more of the expandable tubular members, 12, 14, 24, 26, 102, 104, 106, 108, 202 and/or 204 is greater than 0.12.

[0082] In an exemplary embodiment, a tubular member having a higher expandability coefficient requires less power and/or energy to radially expand and plastically deform each unit length than a tubular member having a lower expandability coefficient. In an exemplary embodiment, a tubular member having a higher expandability coefficient requires less power and/or energy per unit length to radially expand and plastically deform than a tubular member having a lower expandability coefficient.

[0083] In several exemplary experimental embodiments, one or more of the expandable tubular members, 12, 14, 24, 26, 102, 104, 106, 108, 202 and/or 204, are steel alloys having one of the following compositions:

Steel Alloy	Element and Percentage By Weight							
	C	Mn	P	S	Si	Cu	Ni	Cr
A	0.065	1.44	0.01	0.002	0.24	0.01	0.01	0.02

B	0.18	1.28	0.017	0.004	0.29	0.01	0.01	0.03
C	0.08	0.82	0.006	0.003	0.30	0.16	0.05	0.05
D	0.02	1.31	0.02	0.001	0.45	-	9.1	18.7

[0084] In exemplary experimental embodiment, as illustrated in Fig. 20, a sample of an expandable tubular member composed of Alloy A exhibited a yield point before radial expansion and plastic deformation $Y_{P_{BE}}$, a yield point after radial expansion and plastic deformation of about 16 % $Y_{P_{AE16\%}}$, and a yield point after radial expansion and plastic deformation of about 24 % $Y_{P_{AE24\%}}$. In an exemplary experimental embodiment, $Y_{P_{AE24\%}} > Y_{P_{AE16\%}} > Y_{P_{BE}}$. Furthermore, in an exemplary experimental embodiment, the ductility of the sample of the expandable tubular member composed of Alloy A also exhibited a higher ductility prior to radial expansion and plastic deformation than after radial expansion and plastic deformation. These were unexpected results.

[0085] In an exemplary experimental embodiment, a sample of an expandable tubular member composed of Alloy A exhibited the following tensile characteristics before and after radial expansion and plastic deformation:

	Yield Point ksi	Yield Ratio	Elongation %	Width Reduction %	Wall Thickness Reduction %	Anisotropy
Before Radial Expansion and Plastic Deformation	46.9	0.69	53	-52	55	0.93
After 16% Radial Expansion	65.9	0.83	17	42	51	0.78
After 24% Radial Expansion	68.5	0.83	5	44	54	0.76

	Yield Point ksi	Yield Ratio	Elongation %	Width Reduction %	Wall Thickness Reduction %	Anisotropy
% Increase	40% for 16% radial expansion 46% for 24% radial expansion					

[0086] In exemplary experimental embodiment, as illustrated in Fig. 21, a sample of an expandable tubular member composed of Alloy B exhibited a yield point before radial expansion and plastic deformation $Y_{P_{BE}}$, a yield point after radial expansion and plastic deformation of about 16 % $Y_{P_{AE16\%}}$, and a yield point after radial expansion and plastic deformation of about 24 % $Y_{P_{AE24\%}}$. In an exemplary embodiment, $Y_{P_{AE24\%}} > Y_{P_{AE16\%}} > Y_{P_{BE}}$. Furthermore, in an exemplary experimental embodiment, the ductility of the sample of the expandable tubular member composed of Alloy B also exhibited a higher ductility prior to radial expansion and plastic deformation than after radial expansion and plastic deformation. These were unexpected results.

[0087] In an exemplary experimental embodiment, a sample of an expandable tubular member composed of Alloy B exhibited the following tensile characteristics before and after radial expansion and plastic deformation:

	Yield Point ksi	Yield Ratio	Elongation %	Width Reduction %	Wall Thickness Reduction %	Anisotropy
Before Radial Expansion and Plastic Deformation	57.8	0.71	44	43	46	0.93
After 16% Radial	74.4	0.84	16	38	42	0.87

	Yield Point ksi	Yield Ratio	Elongation %	Width Reduction %	Wall Thickness Reduction %	Anisotropy
Expansion						
After 24% Radial Expansion	79.8	0.86	20	36	42	0.81
% Increase	28.7% increase for 16% radial expansion 38% increase for 24% radial expansion					

[0088] In an exemplary experimental embodiment, samples of expandable tubulars composed of Alloys A, B, C, and D exhibited the following tensile characteristics prior to radial expansion and plastic deformation:

Steel Alloy	Yield ksi	Yield Ratio	Elongation %	Anisotropy	Absorbed Energy ft-lb	Expandability Coefficient
A	47.6	0.71	44	1.48	145	
B	57.8	0.71	44	1.04	62.2	
C	61.7	0.80	39	1.92	268	
D	48	0.55	56	1.34	-	

[0089] In an exemplary embodiment, one or more of the expandable tubular members, 12, 14, 24, 26, 102, 104, 106, 108, 202 and/or 204 have a strain hardening exponent greater than 0.12, and a yield ratio is less than 0.85.

[0090] In an exemplary embodiment, the carbon equivalent C_e , for tubular members having a carbon content (by weight percentage) less than or equal to 0.12%, is given by the following expression:

$$C_e = C + Mn/6 + (Cr + Mo + V + Ti + Nb)/5 + (Ni + Cu)/15$$

- where C_e = carbon equivalent value;
- a. C = carbon percentage by weight;
 - b. Mn = manganese percentage by weight;
 - c. Cr = chromium percentage by weight;
 - d. Mo = molybdenum percentage by weight;
 - e. V = vanadium percentage by weight;
 - f. Ti = titanium percentage by weight;
 - g. Nb = niobium percentage by weight;
 - h. Ni = nickel percentage by weight; and
 - i. Cu = copper percentage by weight.

[0091] In an exemplary embodiment, the carbon equivalent value C_e , for tubular members having a carbon content less than or equal to 0.12% (by weight), for one or more of the expandable tubular members, 12, 14, 24, 26, 102, 104, 106, 108, 202 and/or 204 is less than 0.21.

[0092] In an exemplary embodiment, the carbon equivalent C_e , for tubular members having more than 0.12% carbon content (by weight), is given by the following expression:

$$C_e = C + Si/30 + (Mn + Cu + Cr)/20 + Ni/60 + Mo/15 + V/10 + 5 * B$$

- where C_e = carbon equivalent value;
- a. C = carbon percentage by weight;
 - b. Si = silicon percentage by weight;
 - c. Mn = manganese percentage by weight;
 - d. Cu = copper percentage by weight;
 - e. Cr = chromium percentage by weight;
 - f. Ni = nickel percentage by weight;
 - g. Mo = molybdenum percentage by weight;
 - h. V = vanadium percentage by weight; and
 - i. B = boron percentage by weight.

[0093] In an exemplary embodiment, the carbon equivalent value C_e , for tubular members having greater than 0.12% carbon content (by weight), for one or more of the expandable tubular members, 12, 14, 24, 26, 102, 104, 106, 108, 202 and/or 204 is less than 0.36.

[0094] In several exemplary embodiments, the first and second tubular members described above with reference to Figs. 1 to 21 are radially expanded and plastically deformed using the expansion device in a conventional manner and/or using one or more of the methods and apparatus disclosed in one or more of the following: The present application is related to the following: (1) U.S. patent application serial no. 09/454,139, attorney docket no.

25791.03.02, filed on 12/3/1999, (2) U.S. patent application serial no. 09/510,913, attorney docket no. 25791.7.02, filed on 2/23/2000, (3) U.S. patent application serial no. 09/502,350, attorney docket no. 25791.8.02, filed on 2/10/2000, (4) U.S. patent application serial no. 09/440,338, attorney docket no. 25791.9.02, filed on 11/15/1999, (5) U.S. patent application serial no. 09/523,460, attorney docket no. 25791.11.02, filed on 3/10/2000, (6) U.S. patent application serial no. 09/512,895, attorney docket no. 25791.12.02, filed on 2/24/2000, (7) U.S. patent application serial no. 09/511,941, attorney docket no. 25791.16.02, filed on 2/24/2000, (8) U.S. patent application serial no. 09/588,946, attorney docket no. 25791.17.02, filed on 6/7/2000, (9) U.S. patent application serial no. 09/559,122, attorney docket no. 25791.23.02, filed on 4/26/2000, (10) PCT patent application serial no. PCT/US00/18635, attorney docket no. 25791.25.02, filed on 7/9/2000, (11) U.S. provisional patent application serial no. 60/162,671, attorney docket no. 25791.27, filed on 11/1/1999, (12) U.S. provisional patent application serial no. 60/154,047, attorney docket no. 25791.29, filed on 9/16/1999, (13) U.S. provisional patent application serial no. 60/159,082, attorney docket no. 25791.34, filed on 10/12/1999, (14) U.S. provisional patent application serial no. 60/159,039, attorney docket no. 25791.36, filed on 10/12/1999, (15) U.S. provisional patent application serial no. 60/159,033, attorney docket no. 25791.37, filed on 10/12/1999, (16) U.S. provisional patent application serial no. 60/212,359, attorney docket no. 25791.38, filed on 6/19/2000, (17) U.S. provisional patent application serial no. 60/165,228, attorney docket no. 25791.39, filed on 11/12/1999, (18) U.S. provisional patent application serial no. 60/221,443, attorney docket no. 25791.45, filed on 7/28/2000, (19) U.S. provisional patent application serial no. 60/221,645, attorney docket no. 25791.46, filed on 7/28/2000, (20) U.S. provisional patent application serial no. 60/233,638, attorney docket no. 25791.47, filed on 9/18/2000, (21) U.S. provisional patent application serial no. 60/237,334, attorney docket no. 25791.48, filed on 10/2/2000, (22) U.S. provisional patent application serial no. 60/270,007, attorney docket no. 25791.50, filed on 2/20/2001, (23) U.S. provisional patent application serial no. 60/262,434, attorney docket no. 25791.51, filed on 1/17/2001, (24) U.S. provisional patent application serial no. 60/259,486, attorney docket no. 25791.52, filed on 1/3/2001, (25) U.S. provisional patent application serial no. 60/303,740, attorney docket no. 25791.61, filed on 7/6/2001, (26) U.S. provisional patent application serial no. 60/313,453, attorney docket no. 25791.59, filed on 8/20/2001, (27) U.S. provisional patent application serial no. 60/317,985, attorney docket no. 25791.67, filed on 9/6/2001, (28) U.S. provisional patent application serial no. 60/3318,386, attorney docket no. 25791.67.02, filed on 9/10/2001, (29) U.S. utility patent application serial no. 09/969,922, attorney docket no. 25791.69, filed on 10/3/2001, (30) U.S. utility patent application serial no. 10/016,467, attorney docket no. 25791.70, filed on December 10, 2001, (31) U.S. provisional patent application serial no.

60/343,674, attorney docket no. 25791.68, filed on 12/27/2001; and (32) U.S. provisional patent application serial no. 60/346,309, attorney docket no. 25791.92, filed on 01/07/02, the disclosures of which are incorporated herein by reference.

[0095] Referring to Fig. 35a an exemplary embodiment of an expandable tubular member 3500 includes a first tubular region 3502 and a second tubular portion 3504. In an exemplary embodiment, the material properties of the first and second tubular regions, 3502 and 3504, are different. In an exemplary embodiment, the yield points of the first and second tubular regions, 3502 and 3504, are different. In an exemplary embodiment, the yield point of the first tubular region 3502 is less than the yield point of the second tubular region 3504. In several exemplary embodiments, one or more of the expandable tubular members, 12, 14, 24, 26, 102, 104, 106, 108, 202 and/or 204 incorporate the tubular member 3500.

[0096] Referring to Fig. 35b, in an exemplary embodiment, the yield point within the first and second tubular regions, 3502a and 3502b, of the expandable tubular member 3502 vary as a function of the radial position within the expandable tubular member. In an exemplary embodiment, the yield point increases as a function of the radial position within the expandable tubular member 3502. In an exemplary embodiment, the relationship between the yield point and the radial position within the expandable tubular member 3502 is a linear relationship. In an exemplary embodiment, the relationship between the yield point and the radial position within the expandable tubular member 3502 is a non-linear relationship. In an exemplary embodiment, the yield point increases at different rates within the first and second tubular regions, 3502a and 3502b, as a function of the radial position within the expandable tubular member 3502. In an exemplary embodiment, the functional relationship, and value, of the yield points within the first and second tubular regions, 3502a and 3502b, of the expandable tubular member 3502 are modified by the radial expansion and plastic deformation of the expandable tubular member.

[0097] In several exemplary embodiments, one or more of the expandable tubular members, 12, 14, 24, 26, 102, 104, 106, 108, 202, 204 and/or 3502, prior to a radial expansion and plastic deformation, include a microstructure that is a combination of a hard phase, such as martensite, a soft phase, such as ferrite, and a transitional phase, such as retained austenite. In this manner, the hard phase provides high strength, the soft phase provides ductility, and the transitional phase transitions to a hard phase, such as martensite, during a radial expansion and plastic deformation. Furthermore, in this manner, the yield point of the tubular member increases as a result of the radial expansion and plastic deformation. Further, in this manner, the tubular member is ductile, prior to the radial expansion and plastic deformation, thereby facilitating the radial expansion and plastic deformation. In an

exemplary embodiment, the composition of a dual-phase expandable tubular member includes (weight percentages): about 0.1% C, 1.2% Mn, and 0.3% Si.

[0098] In an exemplary experimental embodiment, as illustrated in Figs. 36a-36c, one or more of the expandable tubular members, 12, 14, 24, 26, 102, 104, 106, 108, 202, 204 and/or 3502 are processed in accordance with a method 3600, in which, in step 3602, an expandable tubular member 3602a is provided that is a steel alloy having following material composition (by weight percentage): 0.065% C, 1.44% Mn, 0.01% P, 0.002% S, 0.24% Si, 0.01% Cu, 0.01% Ni, 0.02% Cr, 0.05% V, 0.01%Mo, 0.01% Nb, and 0.01% Ti. In an exemplary experimental embodiment, the expandable tubular member 3602a provided in step 3602 has a yield strength of 45 ksi, and a tensile strength of 69 ksi.

[0099] In an exemplary experimental embodiment, as illustrated in Fig. 36b, in step 3602, the expandable tubular member 3602a includes a microstructure that includes martensite, pearlite, and V, Ni, and/or Ti carbides.

[00100] In an exemplary embodiment, the expandable tubular member 3602a is then heated at a temperature of 790 °C for about 10 minutes in step 3604.

[00101] In an exemplary embodiment, the expandable tubular member 3602a is then quenched in water in step 3606.

[00102] In an exemplary experimental embodiment, as illustrated in Fig. 36c, following the completion of step 3606, the expandable tubular member 3602a includes a microstructure that includes new ferrite, grain pearlite, martensite, and ferrite. In an exemplary experimental embodiment, following the completion of step 3606, the expandable tubular member 3602a has a yield strength of 67 ksi, and a tensile strength of 95 ksi.

[00103] In an exemplary embodiment, the expandable tubular member 3602a is then radially expanded and plastically deformed using one or more of the methods and apparatus described above. In an exemplary embodiment, following the radial expansion and plastic deformation of the expandable tubular member 3602a, the yield strength of the expandable tubular member is about 95 ksi.

[00104] In an exemplary experimental embodiment, as illustrated in Figs. 37a-37c, one or more of the expandable tubular members, 12, 14, 24, 26, 102, 104, 106, 108, 202, 204 and/or 3502 are processed in accordance with a method 3700, in which, in step 3702, an expandable tubular member 3702a is provided that is a steel alloy having following material composition (by weight percentage): 0.18% C, 1.28% Mn, 0.017% P, 0.004% S, 0.29% Si, 0.01% Cu, 0.01% Ni, 0.03% Cr, 0.04% V, 0.01%Mo, 0.03% Nb, and 0.01% Ti. In an exemplary experimental embodiment, the expandable tubular member 3702a provided in step 3702 has a yield strength of 60 ksi, and a tensile strength of 80 ksi.

[00105] In an exemplary experimental embodiment, as illustrated in Fig. 37b, in step 3702, the expandable tubular member 3702a includes a microstructure that includes pearlite and pearlite striation.

[00106] In an exemplary embodiment, the expandable tubular member 3702a is then heated at a temperature of 790 °C for about 10 minutes in step 3704.

[00107] In an exemplary embodiment, the expandable tubular member 3702a is then quenched in water in step 3706.

[00108] In an exemplary experimental embodiment, as illustrated in Fig. 37c, following the completion of step 3706, the expandable tubular member 3702a includes a microstructure that includes ferrite, martensite, and bainite. In an exemplary experimental embodiment, following the completion of step 3706, the expandable tubular member 3702a has a yield strength of 82 ksi, and a tensile strength of 130 ksi.

[00109] In an exemplary embodiment, the expandable tubular member 3702a is then radially expanded and plastically deformed using one or more of the methods and apparatus described above. In an exemplary embodiment, following the radial expansion and plastic deformation of the expandable tubular member 3702a, the yield strength of the expandable tubular member is about 130 ksi.

[00110] In an exemplary experimental embodiment, as illustrated in Figs. 38a-38c, one or more of the expandable tubular members, 12, 14, 24, 26, 102, 104, 106, 108, 202, 204 and/or 3502 are processed in accordance with a method 3800, in which, in step 3802, an expandable tubular member 3802a is provided that is a steel alloy having following material composition (by weight percentage): 0.08% C, 0.82% Mn, 0.006% P, 0.003% S, 0.30% Si, 0.06% Cu, 0.05% Ni, 0.05% Cr, 0.03% V, 0.03% Mo, 0.01% Nb, and 0.01% Ti. In an exemplary experimental embodiment, the expandable tubular member 3802a provided in step 3802 has a yield strength of 56 ksi, and a tensile strength of 75 ksi.

[00111] In an exemplary experimental embodiment, as illustrated in Fig. 38b, in step 3802, the expandable tubular member 3802a includes a microstructure that includes grain pearlite, widmanstatten martensite and carbides of V, Ni, and/or Ti.

[00112] In an exemplary embodiment, the expandable tubular member 3802a is then heated at a temperature of 790 °C for about 10 minutes in step 3804.

[00113] In an exemplary embodiment, the expandable tubular member 3802a is then quenched in water in step 3806.

[00114] In an exemplary experimental embodiment, as illustrated in Fig. 38c, following the completion of step 3806, the expandable tubular member 3802a includes a microstructure that includes bainite, pearlite, and new ferrite. In an exemplary experimental

embodiment, following the completion of step 3806, the expandable tubular member 3802a has a yield strength of 60 ksi, and a tensile strength of 97 ksi.

[00115] In an exemplary embodiment, the expandable tubular member 3802a is then radially expanded and plastically deformed using one or more of the methods and apparatus described above. In an exemplary embodiment, following the radial expansion and plastic deformation of the expandable tubular member 3802a, the yield strength of the expandable tubular member is about 97 ksi.

[00116] In several exemplary embodiments, the teachings of the present disclosure are combined with one or more of the teachings disclosed in FR 2 841 626, filed on 6/28/2002, and published on 1/2/2004, the disclosure of which is incorporated herein by reference.

[00117] An expandable tubular member has been described that includes a steel alloy including: 0.065 % C, 1.44 % Mn, 0.01 % P, 0.002 % S, 0.24 % Si, 0.01 % Cu, 0.01 % Ni, and 0.02 % Cr. In an exemplary embodiment, a yield point of the tubular member is at most about 46.9 ksi prior to a radial expansion and plastic deformation; and a yield point of the tubular member is at least about 65.9 ksi after the radial expansion and plastic deformation. In an exemplary embodiment, the yield point of the tubular member after the radial expansion and plastic deformation is at least about 40 % greater than the yield point of the tubular member prior to the radial expansion and plastic deformation. In an exemplary embodiment, the anisotropy of the tubular member, prior to a radial expansion and plastic deformation, is about 1.48. In an exemplary embodiment, the tubular member includes a wellbore casing, a pipeline, or a structural support.

[00118] An expandable tubular member has been described that includes a steel alloy including: 0.18 % C, 1.28 % Mn, 0.017 % P, 0.004 % S, 0.29 % Si, 0.01 % Cu, 0.01 % Ni, and 0.03 % Cr. In an exemplary embodiment, a yield point of the tubular member is at most about 57.8 ksi prior to a radial expansion and plastic deformation; and the yield point of the tubular member is at least about 74.4 ksi after the radial expansion and plastic deformation. In an exemplary embodiment, a yield point of the of the tubular member after a radial expansion and plastic deformation is at least about 28 % greater than the yield point of the tubular member prior to the radial expansion and plastic deformation. In an exemplary embodiment, the anisotropy of the tubular member, prior to a radial expansion and plastic deformation, is about 1.04. In an exemplary embodiment, the tubular member includes a wellbore casing, a pipeline, or a structural support.

[00119] An expandable tubular member has been described that includes a steel alloy including: 0.08 % C, 0.82 % Mn, 0.006 % P, 0.003 % S, 0.30 % Si, 0.16 % Cu, 0.05 % Ni, and 0.05 % Cr. In an exemplary embodiment, the anisotropy of the tubular member, prior to

a radial expansion and plastic deformation, is about 1.92. In an exemplary embodiment, the tubular member includes a wellbore casing, a pipeline, or a structural support.

[00120] An expandable tubular member has been described that includes a steel alloy including: 0.02 % C, 1.31 % Mn, 0.02 % P, 0.001 % S, 0.45 % Si, 9.1 % Ni, and 18.7 % Cr. In an exemplary embodiment, the anisotropy of the tubular member, prior to a radial expansion and plastic deformation, is about 1.34. In an exemplary embodiment, the tubular member includes a wellbore casing, a pipeline, or a structural support.

[00121] An expandable tubular member has been described, wherein the yield point of the expandable tubular member is at most about 46.9 ksi prior to a radial expansion and plastic deformation; and wherein the yield point of the expandable tubular member is at least about 65.9 ksi after the radial expansion and plastic deformation. In an exemplary embodiment, the tubular member includes a wellbore casing, a pipeline, or a structural support.

[00122] An expandable tubular member has been described, wherein a yield point of the expandable tubular member after a radial expansion and plastic deformation is at least about 40 % greater than the yield point of the expandable tubular member prior to the radial expansion and plastic deformation. In an exemplary embodiment, the tubular member includes a wellbore casing, a pipeline, or a structural support.

[00123] An expandable tubular member has been described, wherein the anisotropy of the expandable tubular member, prior to the radial expansion and plastic deformation, is at least about 1.48. In an exemplary embodiment, the tubular member includes a wellbore casing, a pipeline, or a structural support.

[00124] An expandable tubular member has been described, wherein the yield point of the expandable tubular member is at most about 57.8 ksi prior to the radial expansion and plastic deformation; and wherein the yield point of the expandable tubular member is at least about 74.4 ksi after the radial expansion and plastic deformation. In an exemplary embodiment, the tubular member includes a wellbore casing, a pipeline, or a structural support.

[00125] An expandable tubular member has been described, wherein the yield point of the expandable tubular member after a radial expansion and plastic deformation is at least about 28 % greater than the yield point of the expandable tubular member prior to the radial expansion and plastic deformation. In an exemplary embodiment, the tubular member includes a wellbore casing, a pipeline, or a structural support.

[00126] An expandable tubular member has been described, wherein the anisotropy of the expandable tubular member, prior to the radial expansion and plastic deformation, is at least about 1.04. In an exemplary embodiment, the tubular member includes a wellbore

casing, a pipeline, or a structural support.

[00127] An expandable tubular member has been described, wherein the anisotropy of the expandable tubular member, prior to the radial expansion and plastic deformation, is at least about 1.92. In an exemplary embodiment, the tubular member includes a wellbore casing, a pipeline, or a structural support.

[00128] An expandable tubular member has been described, wherein the anisotropy of the expandable tubular member, prior to the radial expansion and plastic deformation, is at least about 1.34. In an exemplary embodiment, the tubular member includes a wellbore casing, a pipeline, or a structural support.

[00129] An expandable tubular member has been described, wherein the anisotropy of the expandable tubular member, prior to the radial expansion and plastic deformation, ranges from about 1.04 to about 1.92. In an exemplary embodiment, the tubular member includes a wellbore casing, a pipeline, or a structural support.

[00130] An expandable tubular member has been described, wherein the yield point of the expandable tubular member, prior to the radial expansion and plastic deformation, ranges from about 47.6 ksi to about 61.7 ksi. In an exemplary embodiment, the tubular member includes a wellbore casing, a pipeline, or a structural support.

[00131] An expandable tubular member has been described, wherein the expandability coefficient of the expandable tubular member, prior to the radial expansion and plastic deformation, is greater than 0.12. In an exemplary embodiment, the tubular member includes a wellbore casing, a pipeline, or a structural support.

[00132] An expandable tubular member has been described, wherein the expandability coefficient of the expandable tubular member is greater than the expandability coefficient of another portion of the expandable tubular member. In an exemplary embodiment, the tubular member includes a wellbore casing, a pipeline, or a structural support.

[00133] An expandable tubular member has been described, wherein the tubular member has a higher ductility and a lower yield point prior to a radial expansion and plastic deformation than after the radial expansion and plastic deformation. In an exemplary embodiment, the tubular member includes a wellbore casing, a pipeline, or a structural support.

[00134] An expandable tubular member has been described, wherein a yield point of the expandable tubular member after a radial expansion and plastic deformation is at least about 5.8 % greater than the yield point of the expandable tubular member prior to the radial expansion and plastic deformation. In an exemplary embodiment, the tubular member includes a wellbore casing, a pipeline, or a structural support.

[00135] An expandable tubular member has been described that includes: a tubular body; wherein a yield point of an inner tubular portion of the tubular body is less than a yield point of an outer tubular portion of the tubular body. In an exemplary embodiment, the yield point of the inner tubular portion of the tubular body varies as a function of the radial position within the tubular body. In an exemplary embodiment, the yield point of the inner tubular portion of the tubular body varies in a linear fashion as a function of the radial position within the tubular body. In an exemplary embodiment, the yield point of the inner tubular portion of the tubular body varies in a non-linear fashion as a function of the radial position within the tubular body. In an exemplary embodiment, the yield point of the outer tubular portion of the tubular body varies as a function of the radial position within the tubular body. In an exemplary embodiment, the yield point of the outer tubular portion of the tubular body varies in a linear fashion as a function of the radial position within the tubular body. In an exemplary embodiment, the yield point of the outer tubular portion of the tubular body varies in a non-linear fashion as a function of the radial position within the tubular body. In an exemplary embodiment, the yield point of the inner tubular portion of the tubular body varies as a function of the radial position within the tubular body; and wherein the yield point of the outer tubular portion of the tubular body varies as a function of the radial position within the tubular body. In an exemplary embodiment, the yield point of the inner tubular portion of the tubular body varies in a linear fashion as a function of the radial position within the tubular body; and wherein the yield point of the outer tubular portion of the tubular body varies in a linear fashion as a function of the radial position within the tubular body. In an exemplary embodiment, the yield point of the inner tubular portion of the tubular body varies in a linear fashion as a function of the radial position within the tubular body; and wherein the yield point of the outer tubular portion of the tubular body varies in a non-linear fashion as a function of the radial position within the tubular body. In an exemplary embodiment, the yield point of the inner tubular portion of the tubular body varies in a non-linear fashion as a function of the radial position within the tubular body; and wherein the yield point of the outer tubular portion of the tubular body varies in a linear fashion as a function of the radial position within the tubular body. In an exemplary embodiment, the yield point of the inner tubular portion of the tubular body varies in a non-linear fashion as a function of the radial position within the tubular body; and wherein the yield point of the outer tubular portion of the tubular body varies in a non-linear fashion as a function of the radial position within the tubular body. In an exemplary embodiment, the rate of change of the yield point of the inner tubular portion of the tubular body is different than the rate of change of the yield point of the outer tubular portion of the tubular body. In an exemplary embodiment, the rate of change of

the yield point of the inner tubular portion of the tubular body is different than the rate of change of the yield point of the outer tubular portion of the tubular body.

[00136] It is understood that variations may be made in the foregoing without departing from the scope of the invention. For example, the teachings of the present illustrative embodiments may be used to provide a wellbore casing, a pipeline, or a structural support. Furthermore, the elements and teachings of the various illustrative embodiments may be combined in whole or in part in some or all of the illustrative embodiments. In addition, one or more of the elements and teachings of the various illustrative embodiments may be omitted, at least in part, and/or combined, at least in part, with one or more of the other elements and teachings of the various illustrative embodiments.

[00137] Although illustrative embodiments of the invention have been shown and described, a wide range of modification, changes and substitution is contemplated in the foregoing disclosure. In some instances, some features of the present invention may be employed without a corresponding use of the other features. Accordingly, it is appropriate that the appended claims be construed broadly and in a manner consistent with the scope of the invention.

What is claimed is:

1. An expandable tubular member comprising a steel alloy comprising: 0.065 % C, 1.44 % Mn, 0.01 % P, 0.002 % S, 0.24 % Si, 0.01 % Cu, 0.01 % Ni, and 0.02 % Cr.
2. The tubular member of claim 1, wherein a yield point of the tubular member is at most about 46.9 ksi prior to a radial expansion and plastic deformation; and wherein a yield point of the tubular member is at least about 65.9 ksi after the radial expansion and plastic deformation.
3. The tubular member of claim 1, wherein the yield point of the tubular member after the radial expansion and plastic deformation is at least about 40 % greater than the yield point of the tubular member prior to the radial expansion and plastic deformation.
4. The tubular member of claim 1, wherein the anisotropy of the tubular member, prior to a radial expansion and plastic deformation, is about 1.48.
5. The tubular member of claim 1, wherein the tubular member comprises a wellbore casing.
6. The tubular member of claim 1, wherein the tubular member comprises a pipeline.
7. The tubular member of claim 1, wherein the tubular member comprises a structural support.
8. An expandable tubular member comprising a steel alloy comprising: 0.18 % C, 1.28 % Mn, 0.017 % P, 0.004 % S, 0.29 % Si, 0.01 % Cu, 0.01 % Ni, and 0.03 % Cr.
9. The tubular member of claim 8, wherein a yield point of the tubular member is at most about 57.8 ksi prior to a radial expansion and plastic deformation; and wherein the yield point of the tubular member is at least about 74.4 ksi after the radial expansion and plastic deformation.
10. The tubular member of claim 8, wherein a yield point of the of the tubular member after a radial expansion and plastic deformation is at least about 28 % greater than the yield point of the tubular member prior to the radial expansion and plastic deformation.

11. The tubular member of claim 8, wherein the anisotropy of the tubular member, prior to a radial expansion and plastic deformation, is about 1.04.
12. The tubular member of claim 8, wherein the tubular member comprises a wellbore casing.
13. The tubular member of claim 8, wherein the tubular member comprises a pipeline.
14. The tubular member of claim 8, wherein the tubular member comprises a structural support.
15. An expandable tubular member comprising a steel alloy comprising: 0.08 % C, 0.82 % Mn, 0.006 % P, 0.003 % S, 0.30 % Si, 0.16 % Cu, 0.05 % Ni, and 0.05 % Cr.
16. The tubular member of claim 15, wherein the anisotropy of the tubular member, prior to a radial expansion and plastic deformation, is about 1.92.
17. The tubular member of claim 15, wherein the tubular member comprises a wellbore casing.
18. The tubular member of claim 15, wherein the tubular member comprises a pipeline.
19. The tubular member of claim 15, wherein the tubular member comprises a structural support.
20. An expandable tubular member comprising a steel alloy comprising: 0.02 % C, 1.31 % Mn, 0.02 % P, 0.001 % S, 0.45 % Si, 9.1 % Ni, and 18.7 % Cr.
21. The tubular member of claim 20, wherein the anisotropy of the tubular member, prior to a radial expansion and plastic deformation, is about 1.34.
22. The tubular member of claim 20, wherein the tubular member comprises a wellbore casing.
23. The tubular member of claim 20, wherein the tubular member comprises a pipeline.

24. The tubular member of claim 20, wherein the tubular member comprises a structural support.
25. An expandable tubular member, wherein the yield point of the expandable tubular member is at most about 46.9 ksi prior to a radial expansion and plastic deformation; and wherein the yield point of the expandable tubular member is at least about 65.9 ksi after the radial expansion and plastic deformation.
26. The tubular member of claim 25, wherein the tubular member comprises a wellbore casing.
27. The tubular member of claim 25, wherein the tubular member comprises a pipeline.
28. The tubular member of claim 25, wherein the tubular member comprises a structural support.
29. An expandable tubular member, wherein a yield point of the expandable tubular member after a radial expansion and plastic deformation is at least about 40% greater than the yield point of the expandable tubular member prior to the radial expansion and plastic deformation.
30. The tubular member of claim 29, wherein the tubular member comprises a wellbore casing.
31. The tubular member of claim 29, wherein the tubular member comprises a pipeline.
32. The tubular member of claim 29, wherein the tubular member comprises a structural support.
33. An expandable tubular member, wherein the anisotropy of the expandable tubular member, prior to the radial expansion and plastic deformation, is at least about 1.48.
34. The tubular member of claim 33, wherein the tubular member comprises a wellbore casing.

35. The tubular member of claim 33, wherein the tubular member comprises a pipeline.
36. The tubular member of claim 33, wherein the tubular member comprises a structural support.
37. An expandable tubular member, wherein the yield point of the expandable tubular member is at most about 57.8 ksi prior to the radial expansion and plastic deformation; and wherein the yield point of the expandable tubular member is at least about 74.4 ksi after the radial expansion and plastic deformation.
38. The tubular member of claim 37, wherein the tubular member comprises a wellbore casing.
39. The tubular member of claim 37, wherein the tubular member comprises a pipeline.
40. The tubular member of claim 37, wherein the tubular member comprises a structural support.
41. An expandable tubular member, wherein the yield point of the expandable tubular member after a radial expansion and plastic deformation is at least about 28 % greater than the yield point of the expandable tubular member prior to the radial expansion and plastic deformation.
42. The tubular member of claim 41, wherein the tubular member comprises a wellbore casing.
43. The tubular member of claim 41, wherein the tubular member comprises a pipeline.
44. The tubular member of claim 41, wherein the tubular member comprises a structural support.
45. An expandable tubular member, wherein the anisotropy of the expandable tubular member, prior to the radial expansion and plastic deformation, is at least about 1.04.
46. The tubular member of claim 45, wherein the tubular member comprises a wellbore casing.

47. The tubular member of claim 45, wherein the tubular member comprises a pipeline.
48. The tubular member of claim 45, wherein the tubular member comprises a structural support.
49. An expandable tubular member, wherein the anisotropy of the expandable tubular member, prior to the radial expansion and plastic deformation, is at least about 1.92.
50. The tubular member of claim 49, wherein the tubular member comprises a wellbore casing.
51. The tubular member of claim 49, wherein the tubular member comprises a pipeline.
52. The tubular member of claim 49, wherein the tubular member comprises a structural support.
53. An expandable tubular member, wherein the anisotropy of the expandable tubular member, prior to the radial expansion and plastic deformation, is at least about 1.34.
54. The tubular member of claim 53, wherein the tubular member comprises a wellbore casing.
55. The tubular member of claim 53, wherein the tubular member comprises a pipeline.
56. The tubular member of claim 53, wherein the tubular member comprises a structural support.
57. An expandable tubular member, wherein the anisotropy of the expandable tubular member, prior to the radial expansion and plastic deformation, ranges from about 1.04 to about 1.92.
58. The tubular member of claim 57, wherein the tubular member comprises a wellbore casing.
59. The tubular member of claim 57, wherein the tubular member comprises a pipeline.

60. The tubular member of claim 57, wherein the tubular member comprises a structural support.
61. An expandable tubular member, wherein the yield point of the expandable tubular member, prior to the radial expansion and plastic deformation, ranges from about 47.6 ksi to about 61.7 ksi.
62. The tubular member of claim 61, wherein the tubular member comprises a wellbore casing.
63. The tubular member of claim 61, wherein the tubular member comprises a pipeline.
64. The tubular member of claim 61, wherein the tubular member comprises a structural support.
65. An expandable tubular member, wherein the expandability coefficient of the expandable tubular member, prior to the radial expansion and plastic deformation, is greater than 0.12.
66. The tubular member of claim 65, wherein the tubular member comprises a wellbore casing.
67. The tubular member of claim 65, wherein the tubular member comprises a pipeline.
68. The tubular member of claim 65, wherein the tubular member comprises a structural support.
69. An expandable tubular member, wherein the expandability coefficient of the expandable tubular member is greater than the expandability coefficient of another portion of the expandable tubular member.
70. The tubular member of claim 69, wherein the tubular member comprises a wellbore casing.
71. The tubular member of claim 69, wherein the tubular member comprises a pipeline.

72. The tubular member of claim 69, wherein the tubular member comprises a structural support.
73. An expandable tubular member, wherein the tubular member has a higher ductility and a lower yield point prior to a radial expansion and plastic deformation than after the radial expansion and plastic deformation.
74. The tubular member of claim 73, wherein the tubular member comprises a wellbore casing.
75. The tubular member of claim 73, wherein the tubular member comprises a pipeline.
76. The tubular member of claim 73, wherein the tubular member comprises a structural support.
77. An expandable tubular member, wherein a yield point of the expandable tubular member after a radial expansion and plastic deformation is at least about 5.8 % greater than the yield point of the expandable tubular member prior to the radial expansion and plastic deformation.
78. The tubular member of claim 77, wherein the tubular member comprises a wellbore casing.
79. The tubular member of claim 77, wherein the tubular member comprises a pipeline.
80. The tubular member of claim 77, wherein the tubular member comprises a structural support.
81. An expandable tubular member, comprising:
a tubular body;
wherein a yield point of an inner tubular portion of the tubular body is less than a yield point of an outer tubular portion of the tubular body.

82. The expandable tubular member of claim 81, wherein the yield point of the inner tubular portion of the tubular body varies as a function of the radial position within the tubular body.

83. The expandable tubular member of claim 82, wherein the yield point of the inner tubular portion of the tubular body varies in a linear fashion as a function of the radial position within the tubular body.

84. The expandable tubular member of claim 82, wherein the yield point of the inner tubular portion of the tubular body varies in a non-linear fashion as a function of the radial position within the tubular body.

85. The expandable tubular member of claim 81, wherein the yield point of the outer tubular portion of the tubular body varies as a function of the radial position within the tubular body.

86. The expandable tubular member of claim 85, wherein the yield point of the outer tubular portion of the tubular body varies in a linear fashion as a function of the radial position within the tubular body.

87. The expandable tubular member of claim 85, wherein the yield point of the outer tubular portion of the tubular body varies in a non-linear fashion as a function of the radial position within the tubular body.

88. The expandable tubular member of claim 81,
wherein the yield point of the inner tubular portion of the tubular body varies as a function of the radial position within the tubular body; and
wherein the yield point of the outer tubular portion of the tubular body varies as a function of the radial position within the tubular body.

89. The expandable tubular member of claim 88, wherein the yield point of the inner tubular portion of the tubular body varies in a linear fashion as a function of the radial position within the tubular body; and wherein the yield point of the outer tubular portion of the tubular body varies in a linear fashion as a function of the radial position within the tubular body.

90. The expandable tubular member of claim 88, wherein the yield point of the inner tubular portion of the tubular body varies in a linear fashion as a function of the radial position within the tubular body; and wherein the yield point of the outer tubular portion of the tubular body varies in a non-linear fashion as a function of the radial position within the tubular body.

91. The expandable tubular member of claim 88, wherein the yield point of the inner tubular portion of the tubular body varies in a non-linear fashion as a function of the radial position within the tubular body; and wherein the yield point of the outer tubular portion of the tubular body varies in a linear fashion as a function of the radial position within the tubular body.

92. The expandable tubular member of claim 88, wherein the yield point of the inner tubular portion of the tubular body varies in a non-linear fashion as a function of the radial position within the tubular body; and wherein the yield point of the outer tubular portion of the tubular body varies in a non-linear fashion as a function of the radial position within the tubular body.

93. The expandable tubular member of claim 88, wherein the rate of change of the yield point of the inner tubular portion of the tubular body is different than the rate of change of the yield point of the outer tubular portion of the tubular body.

94. The expandable tubular member of claim 88, wherein the rate of change of the yield point of the inner tubular portion of the tubular body is different than the rate of change of the yield point of the outer tubular portion of the tubular body.

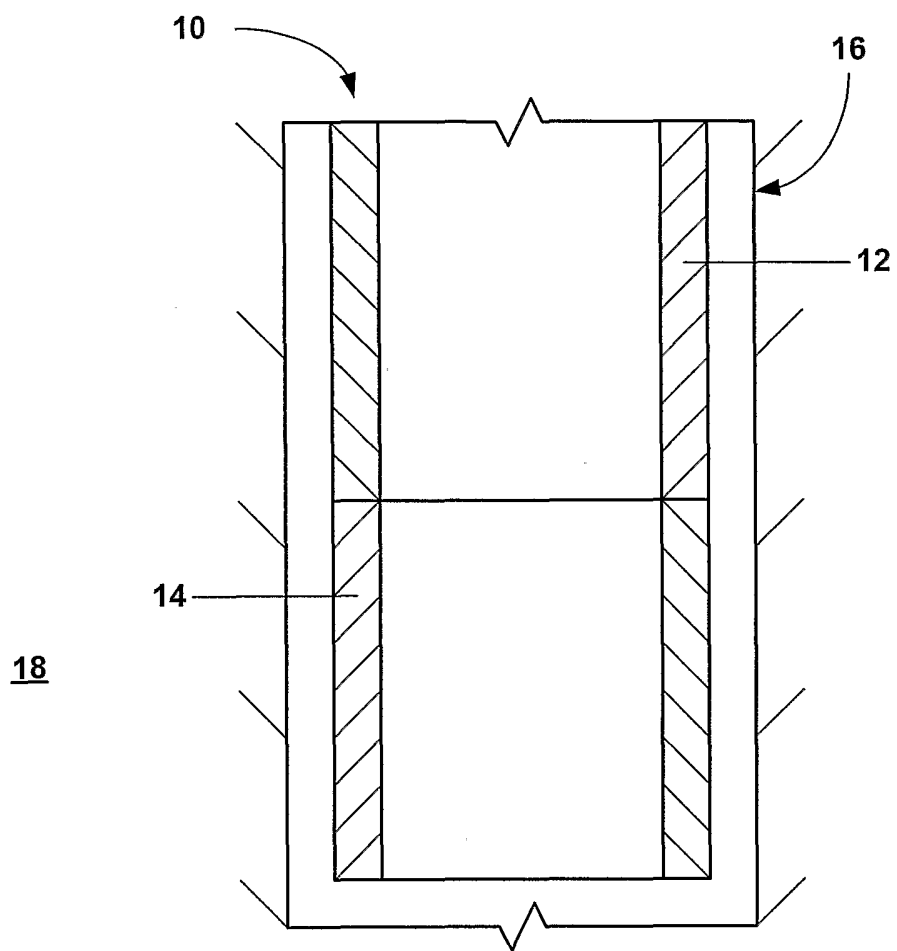

FIG. 1

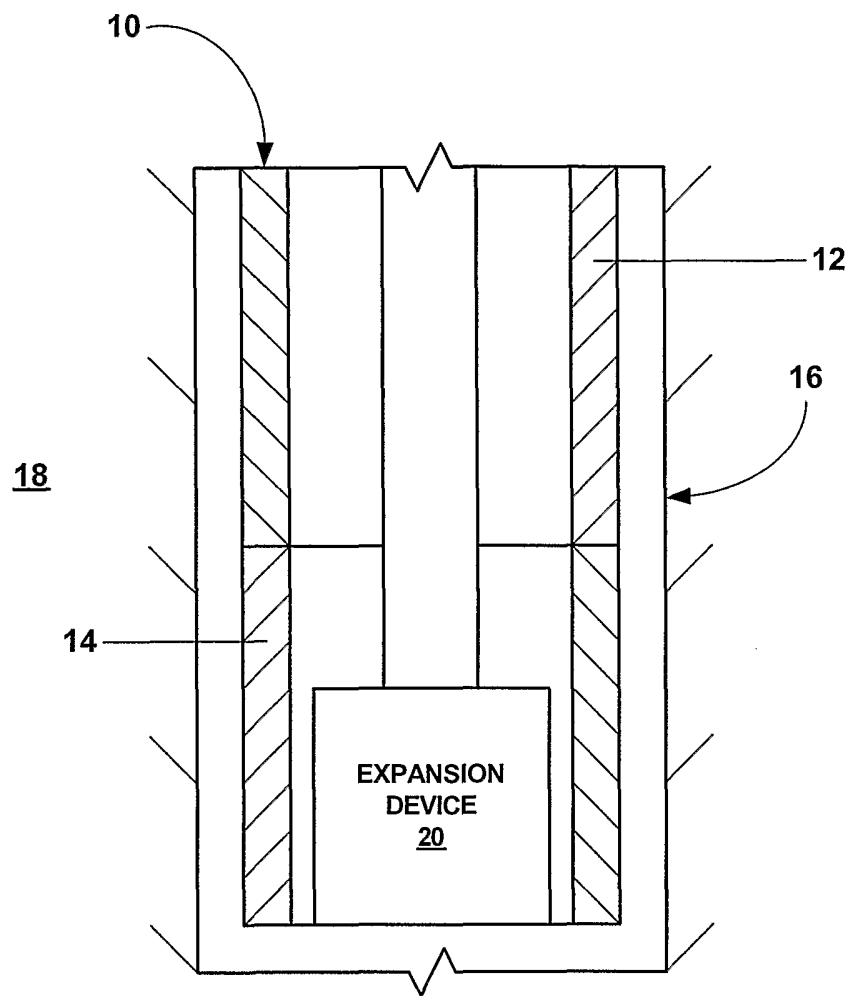

FIG. 2

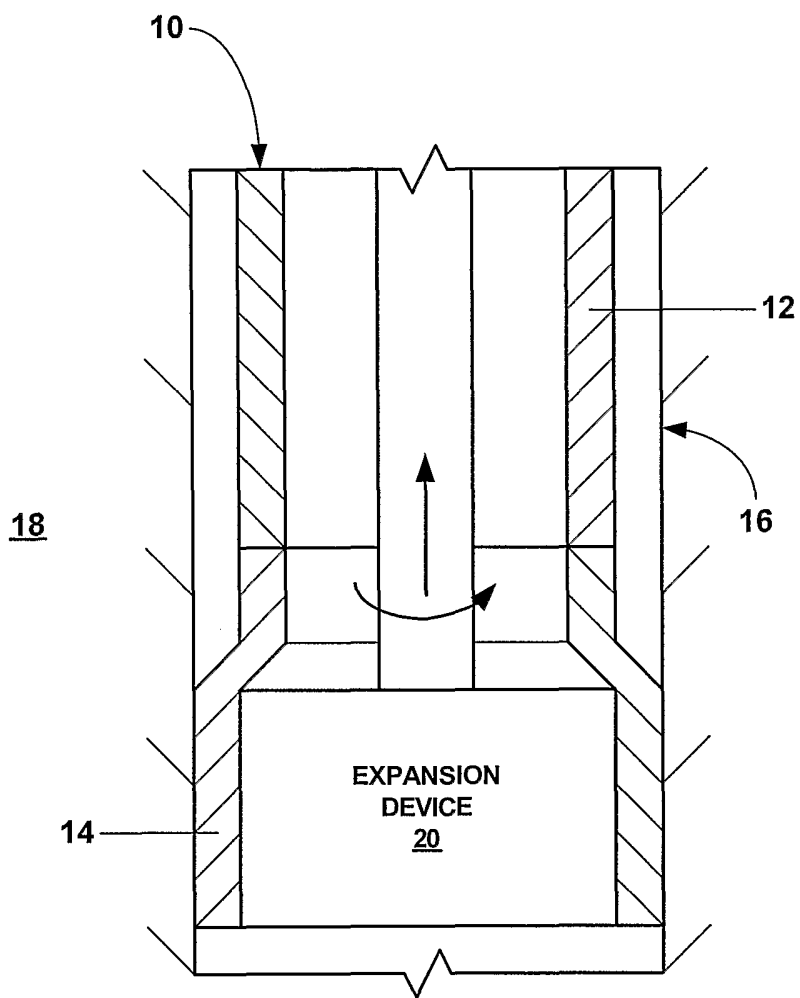

FIG. 3

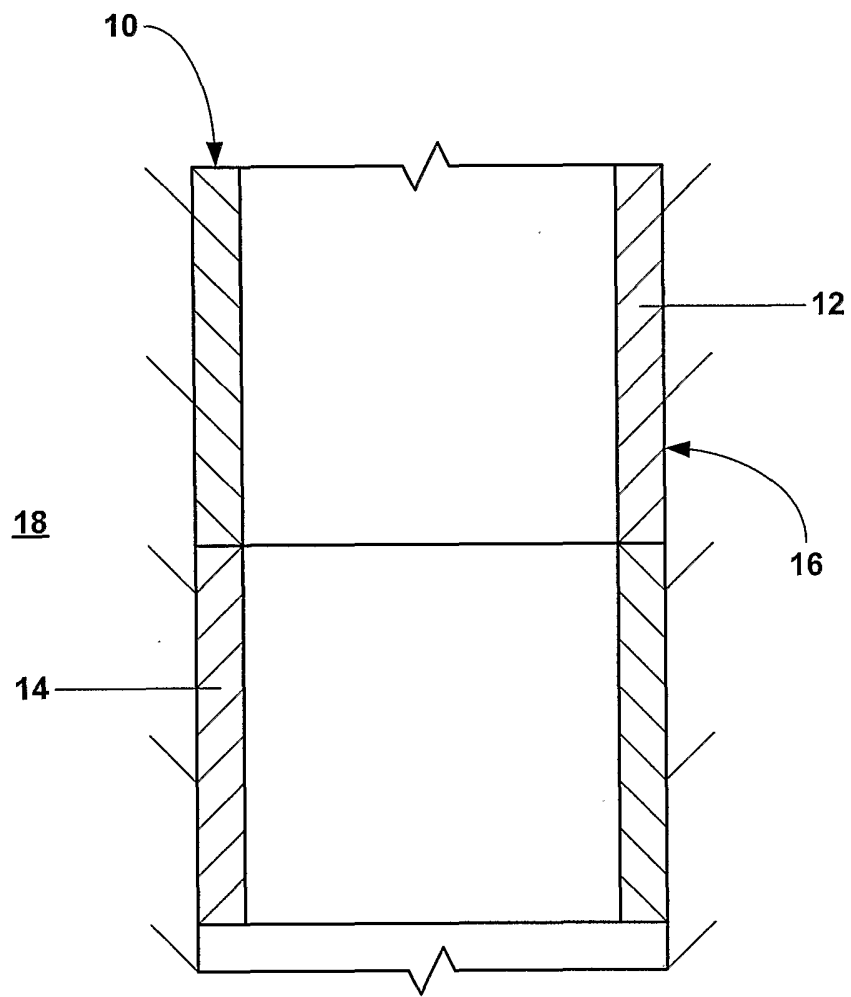

FIG. 4

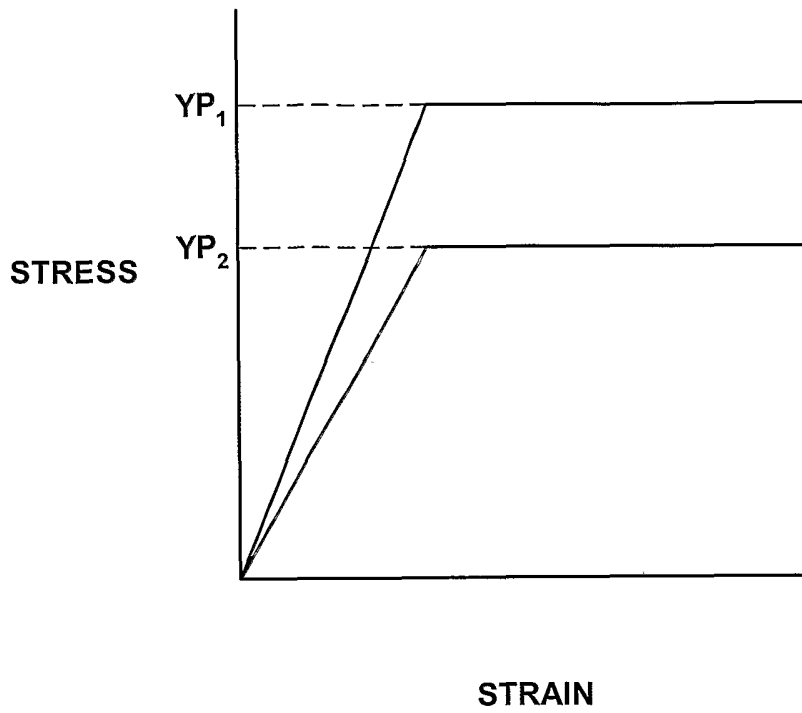

FIG. 5

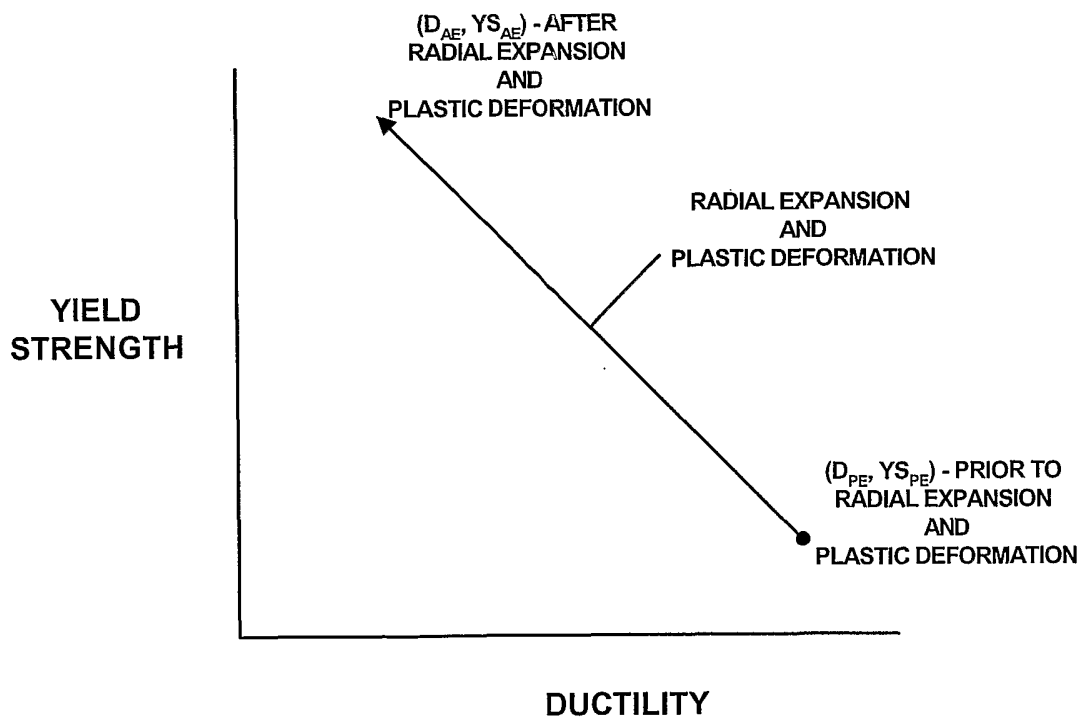

FIG. 6

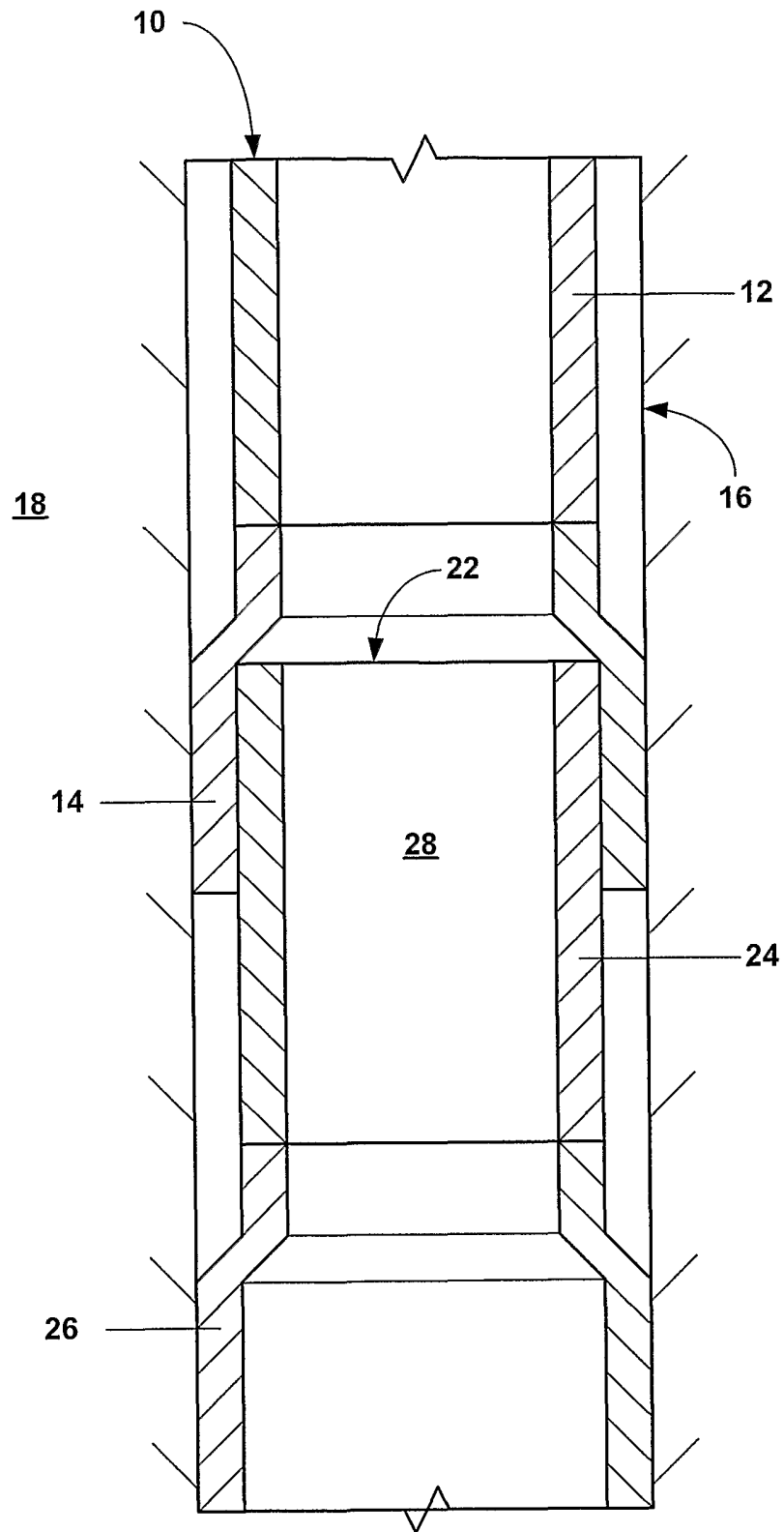

FIG. 7

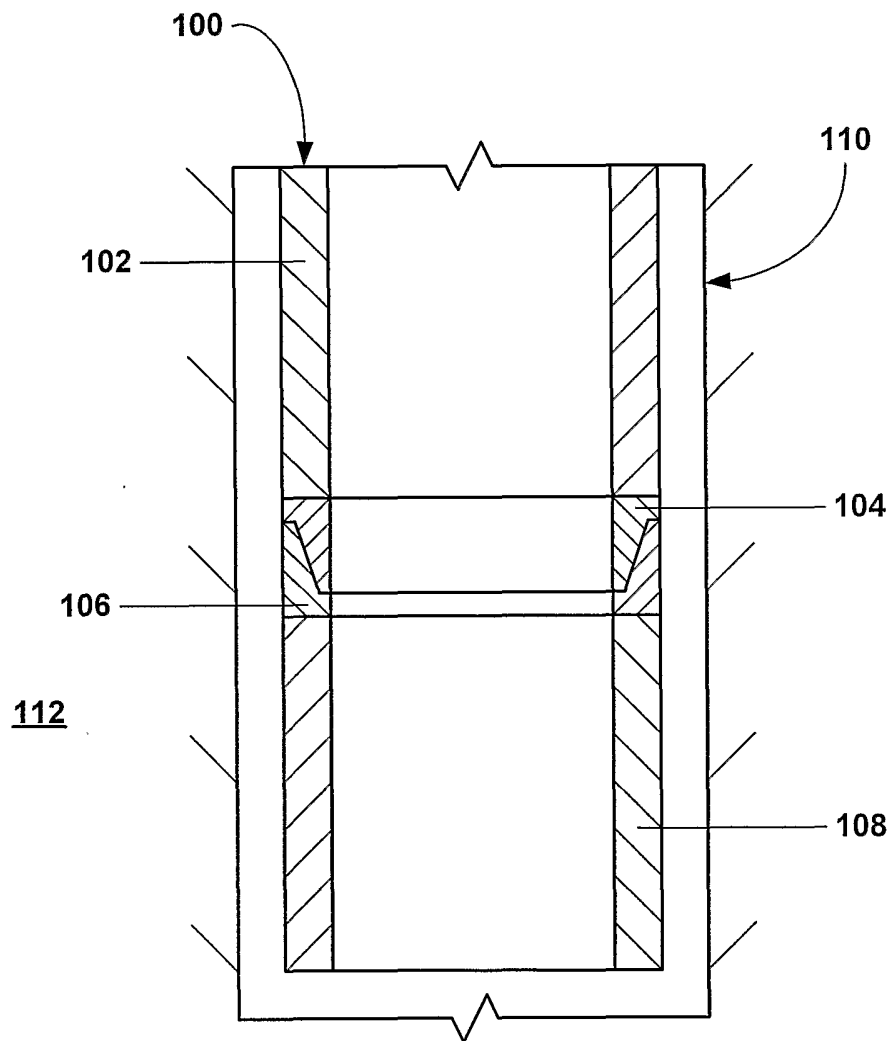

FIG. 8

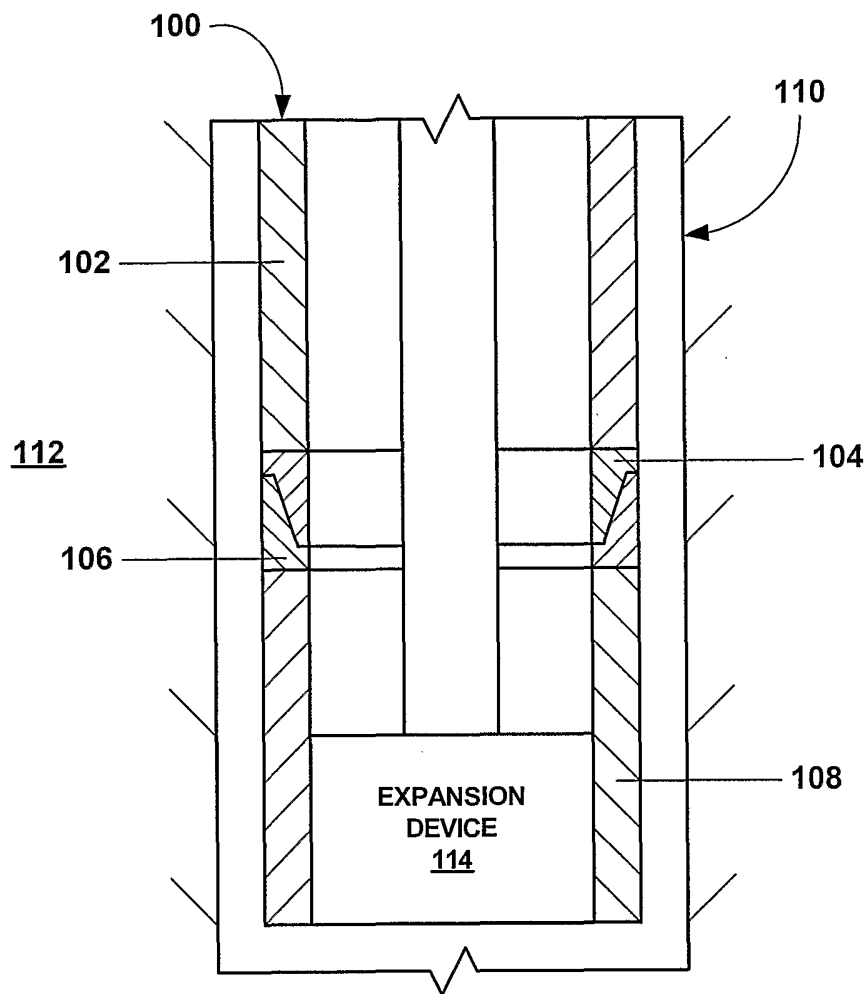

FIG. 9

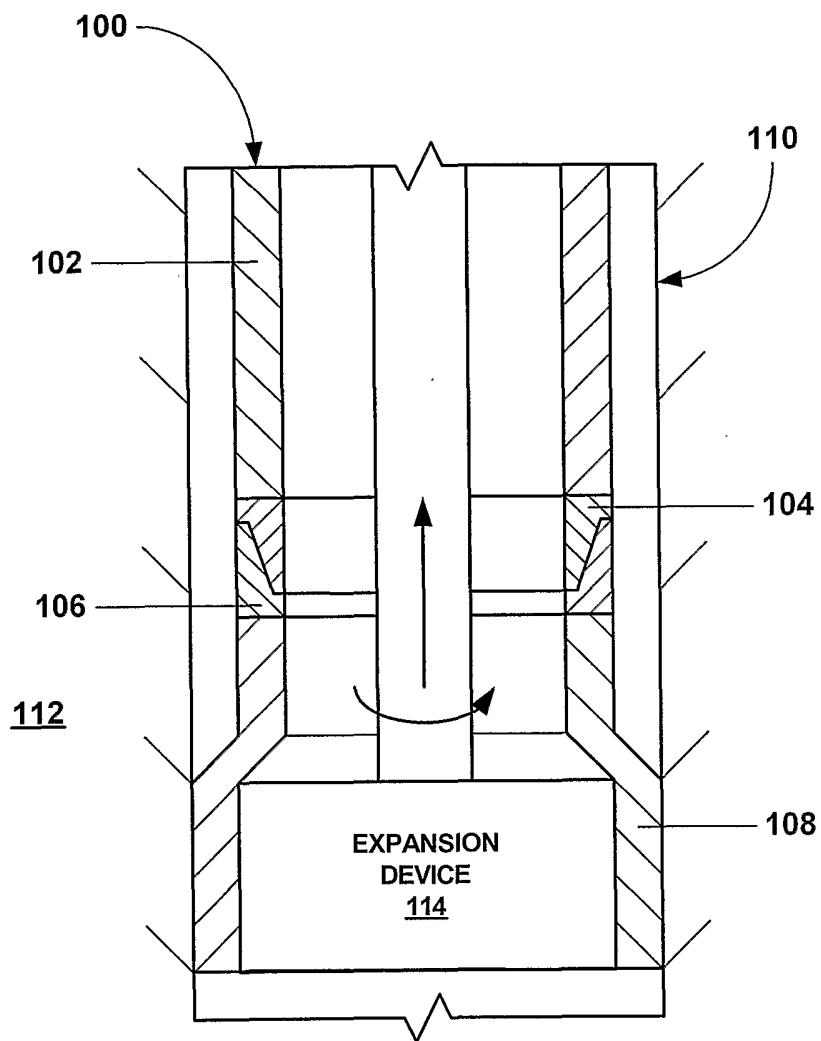

FIG. 10

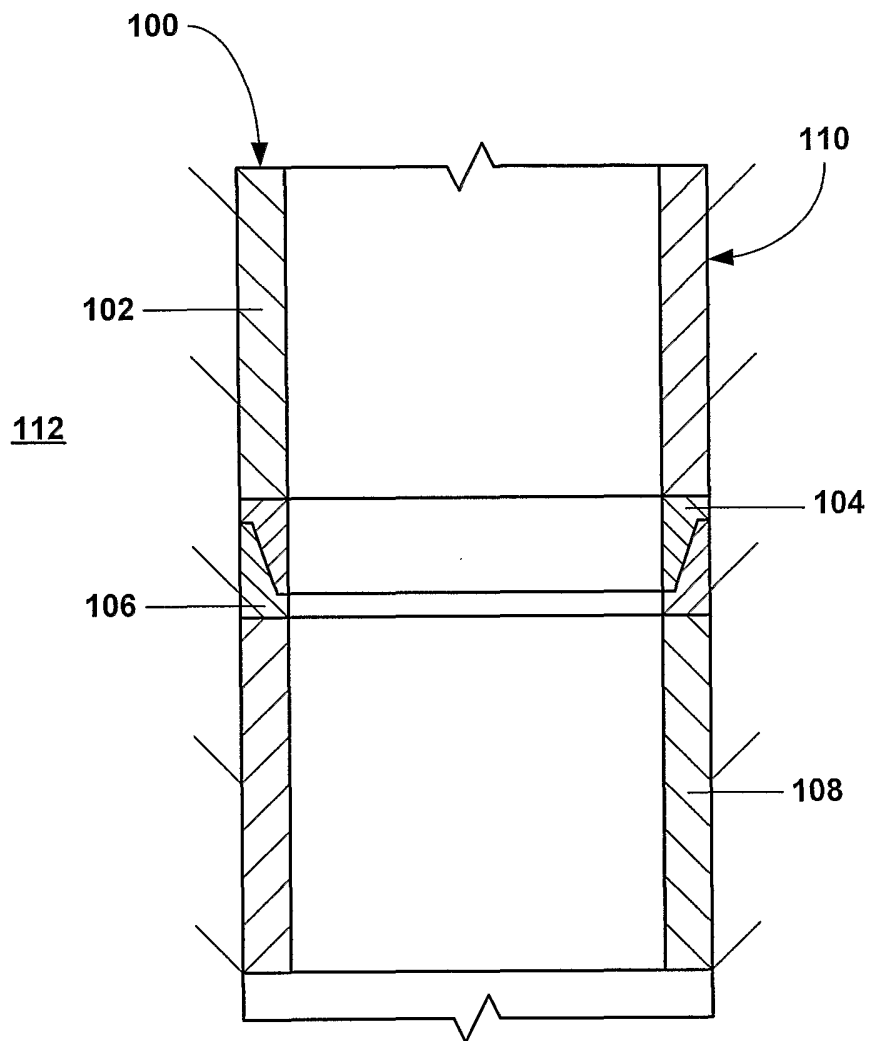

FIG. 11

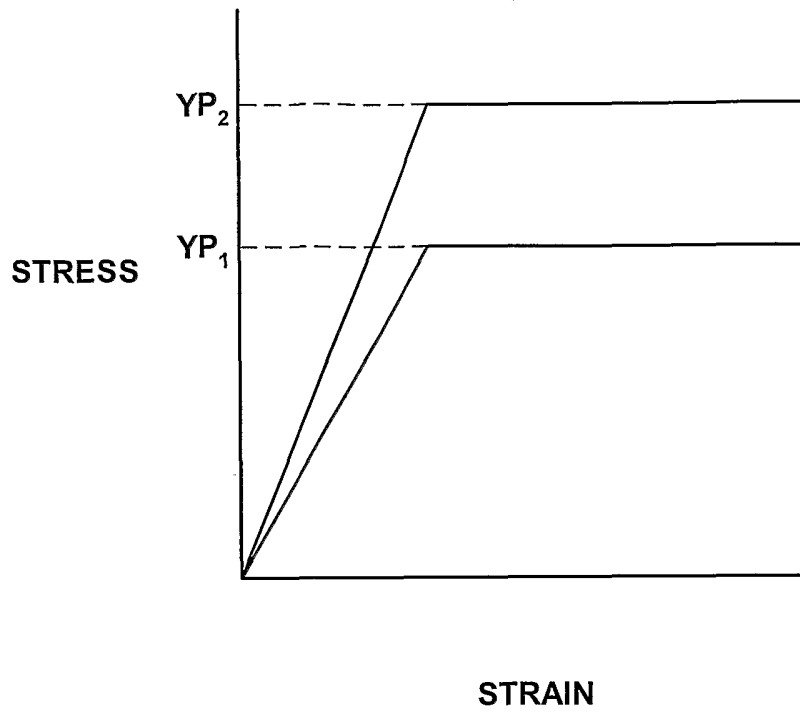

FIG. 12

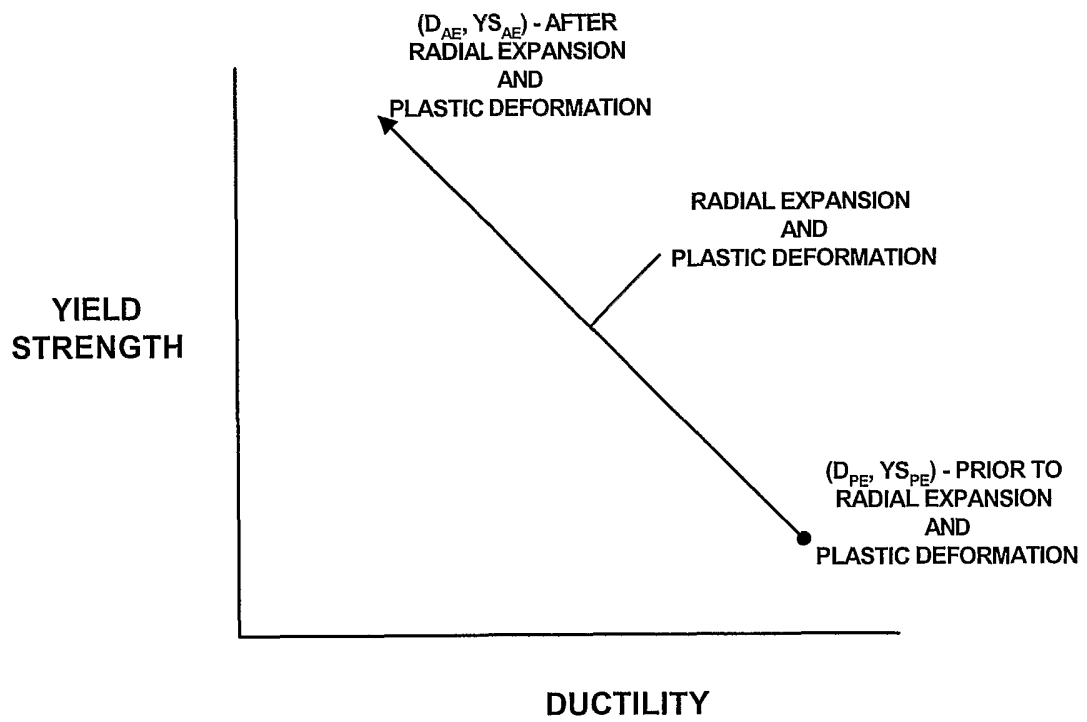

FIG. 13

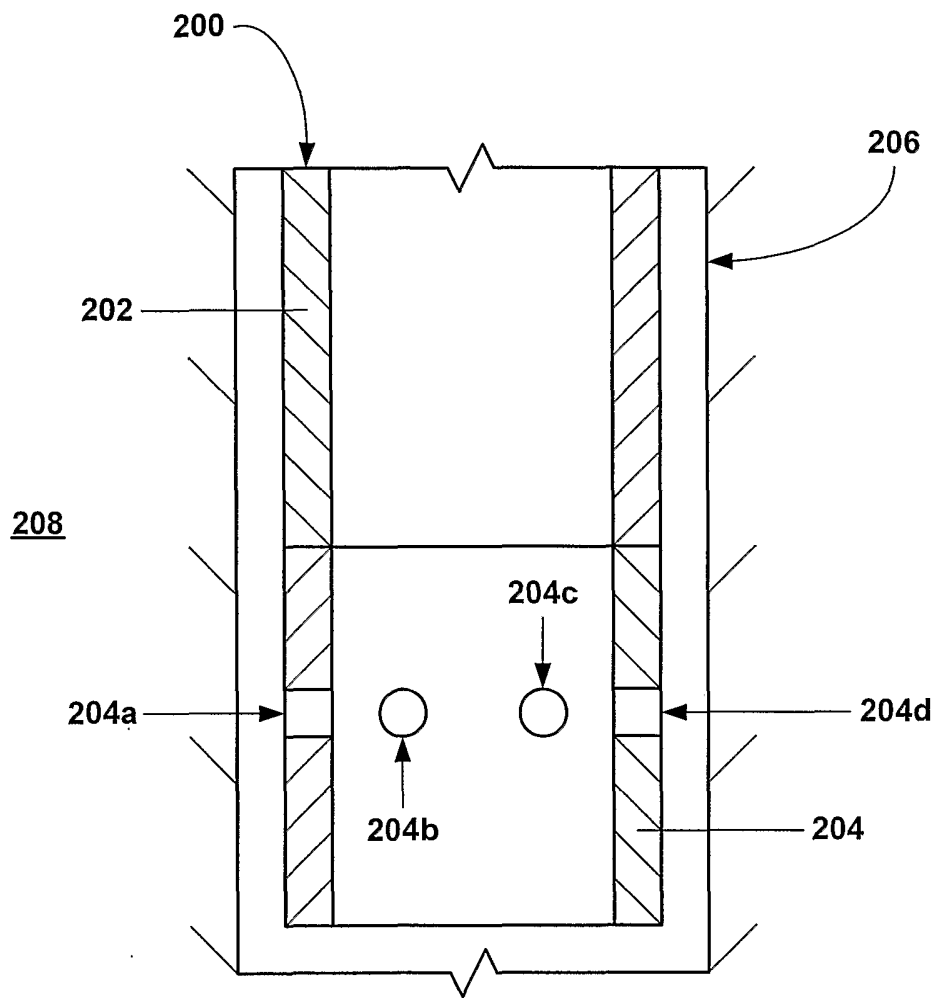

FIG. 14

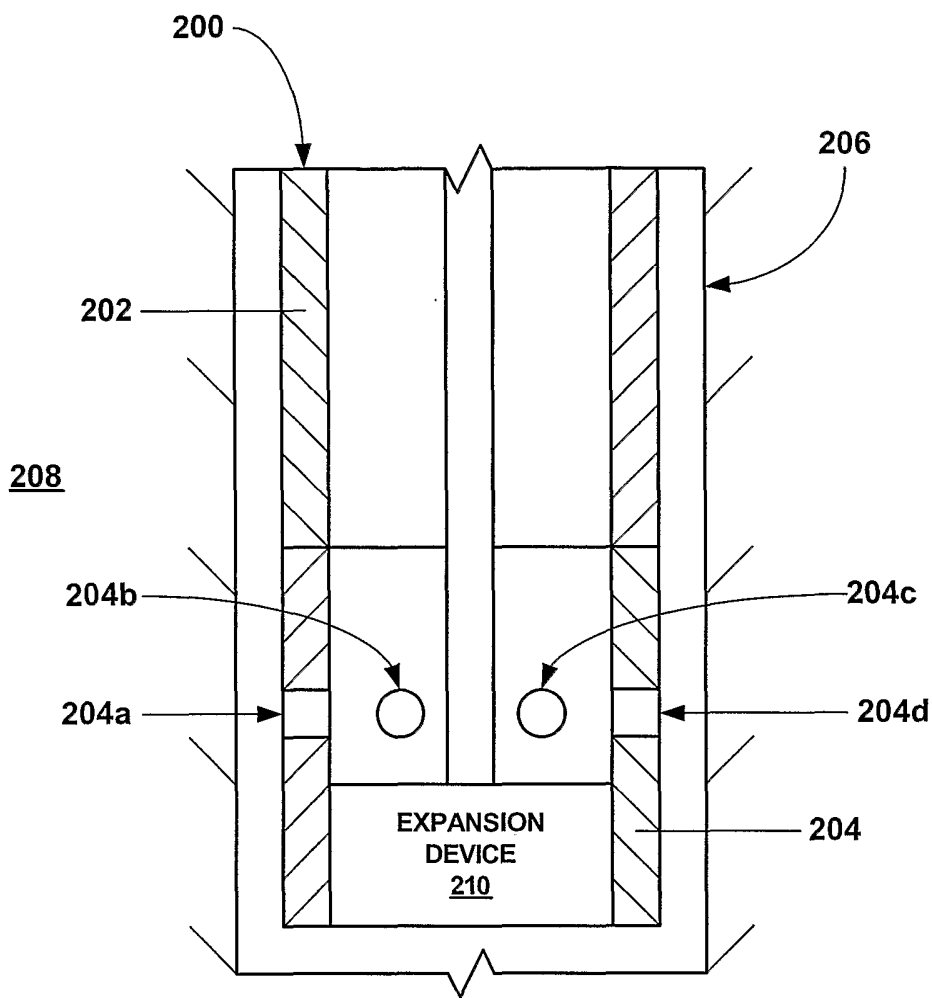

FIG. 15

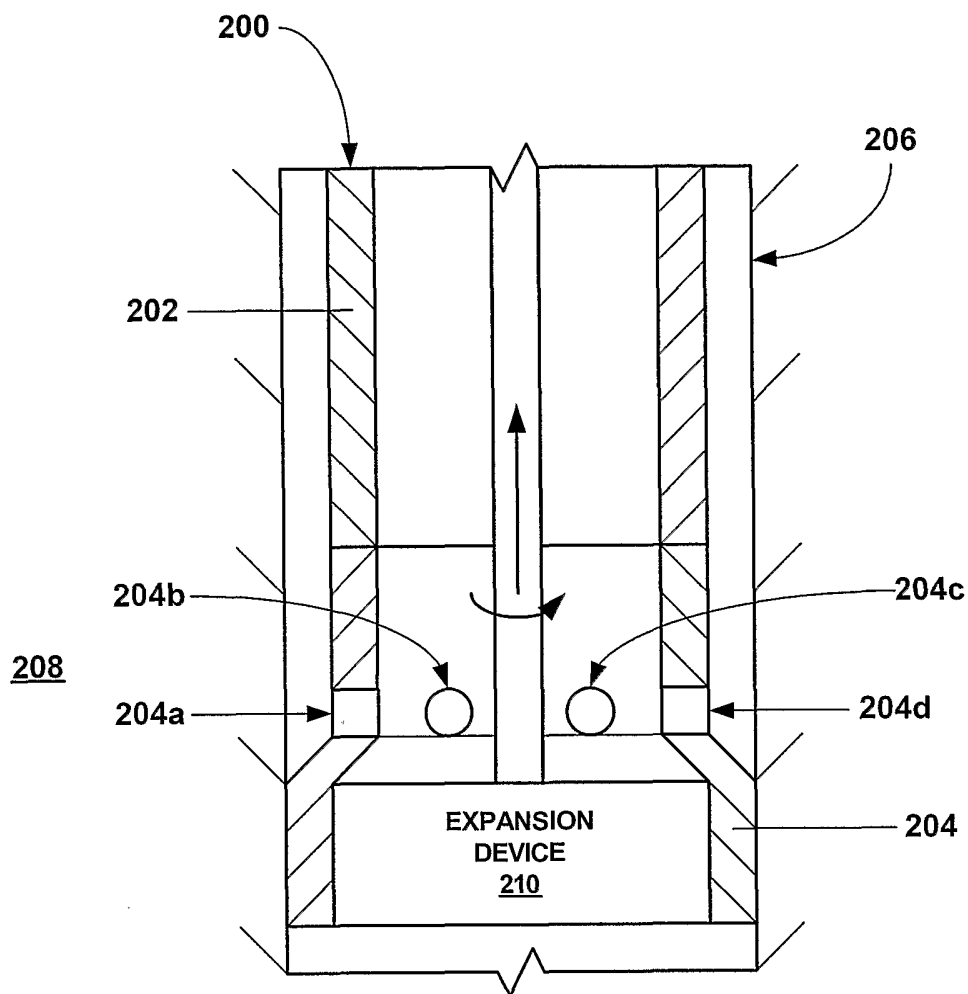

FIG. 16

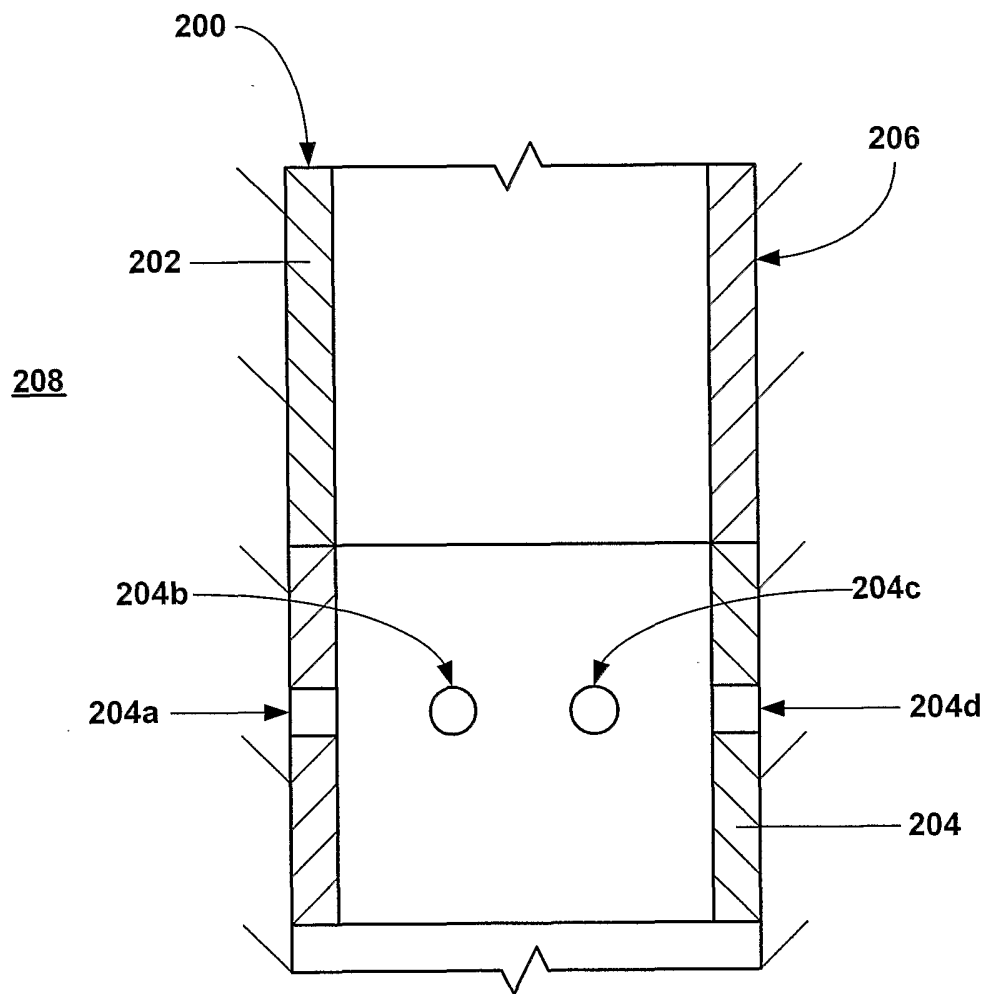

FIG. 17

300
↘

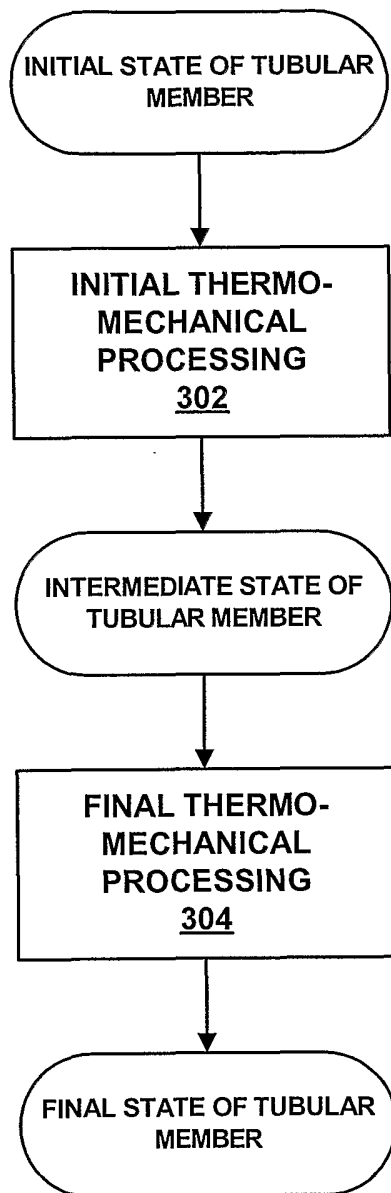

Fig. 18

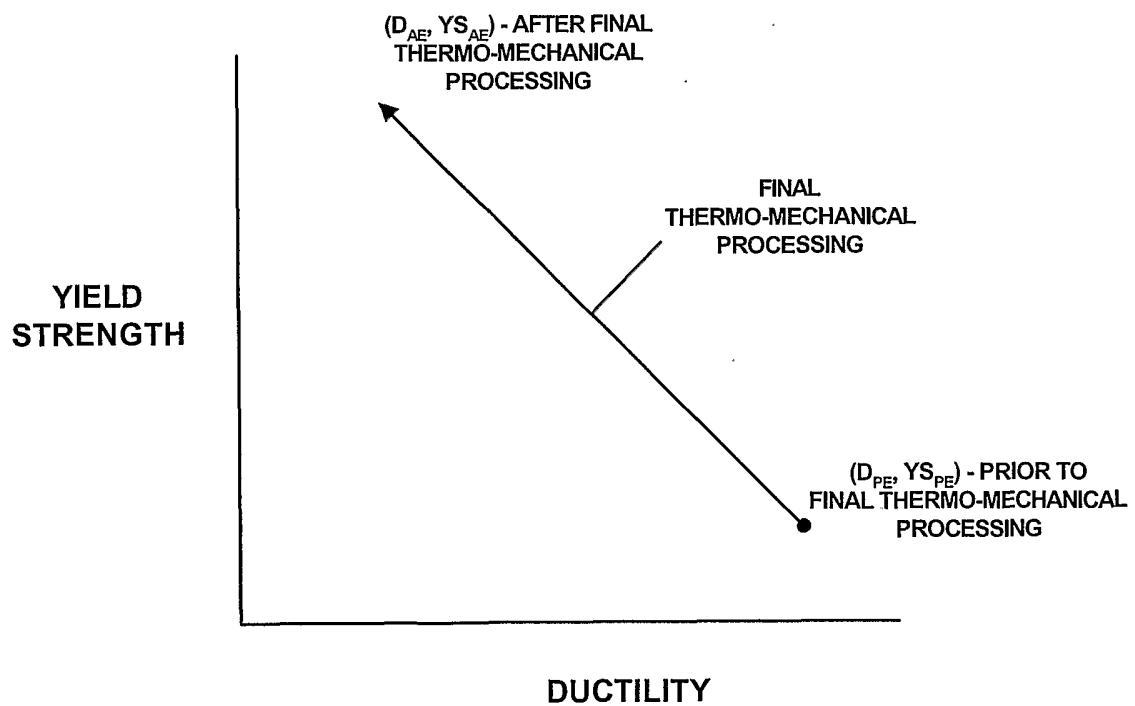

FIG. 19

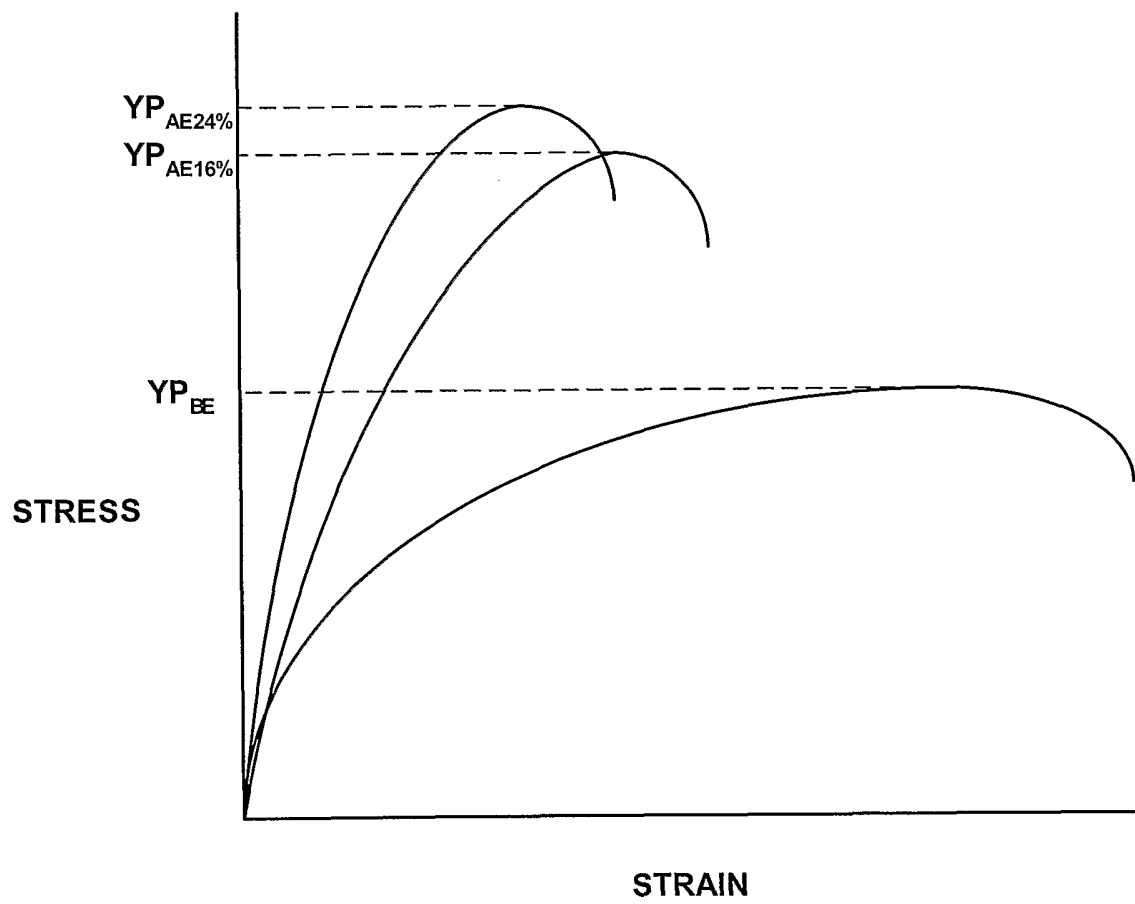

FIG. 20

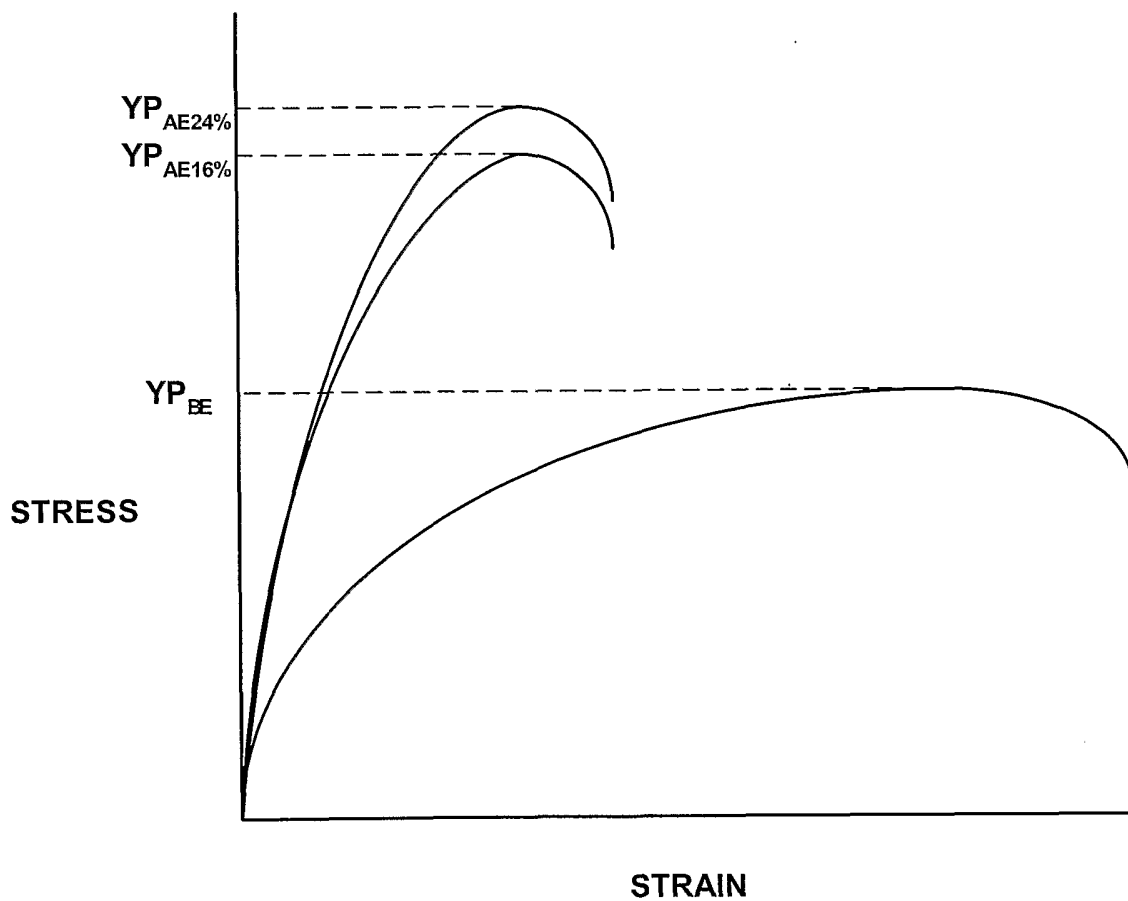

FIG. 21

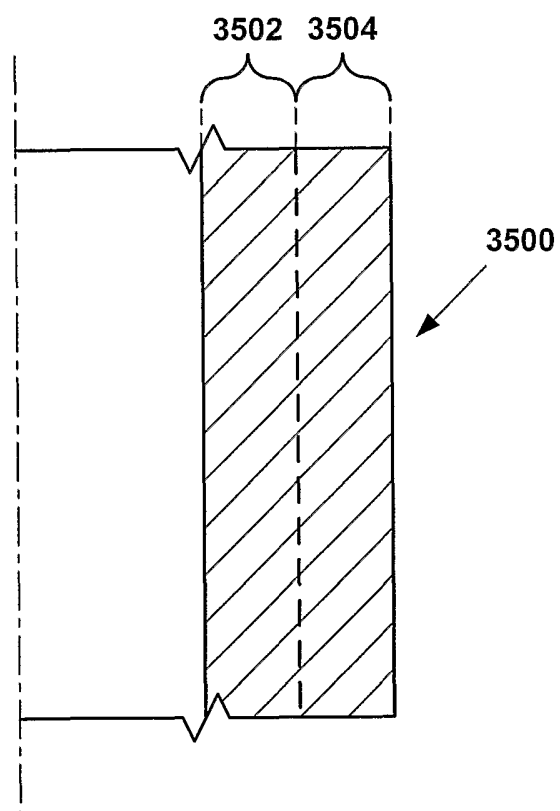

FIG. 35a

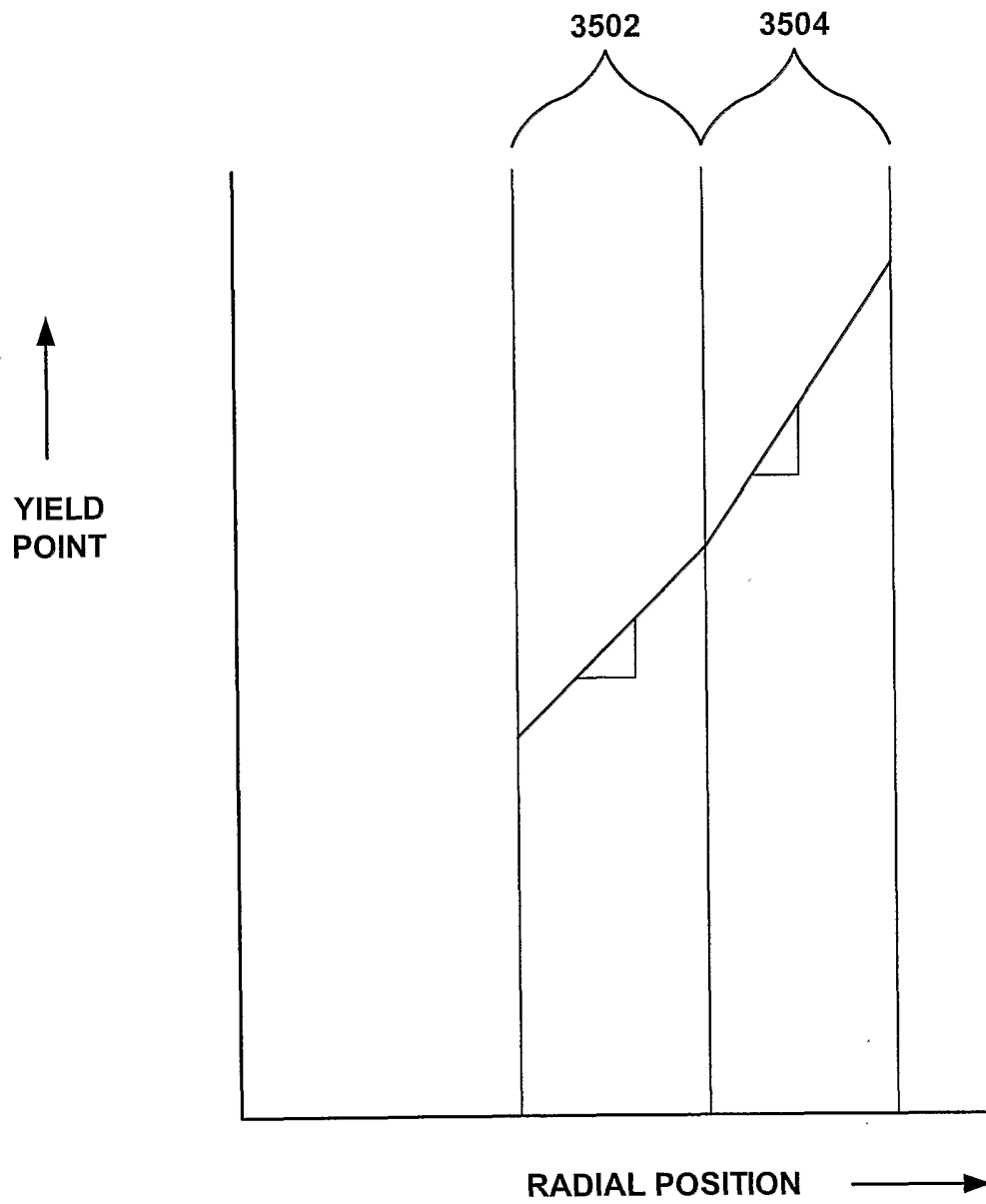

FIG. 35b

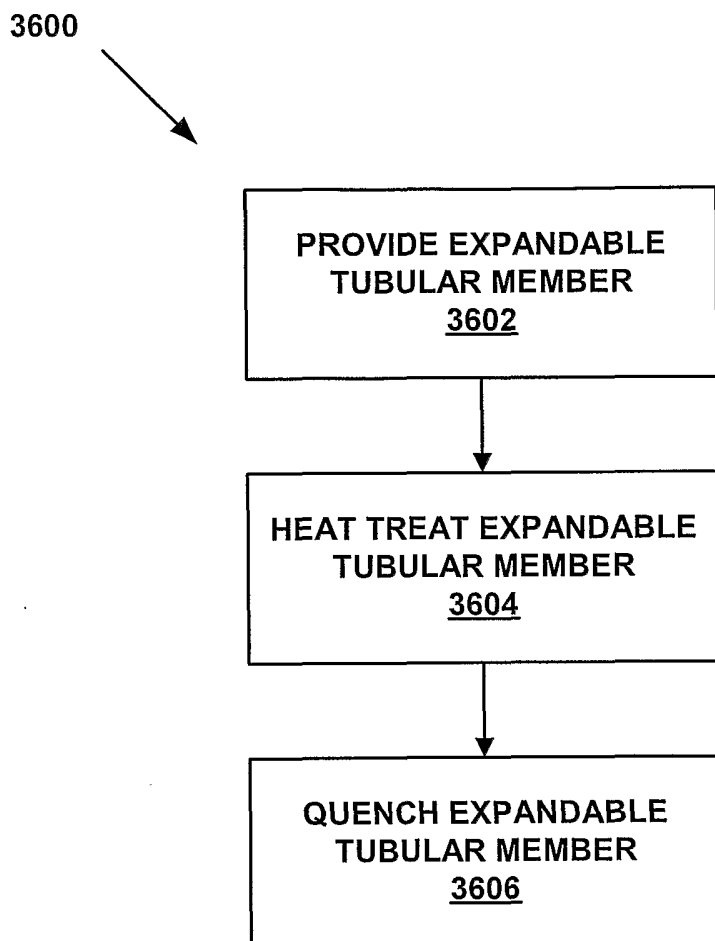

FIG. 36a

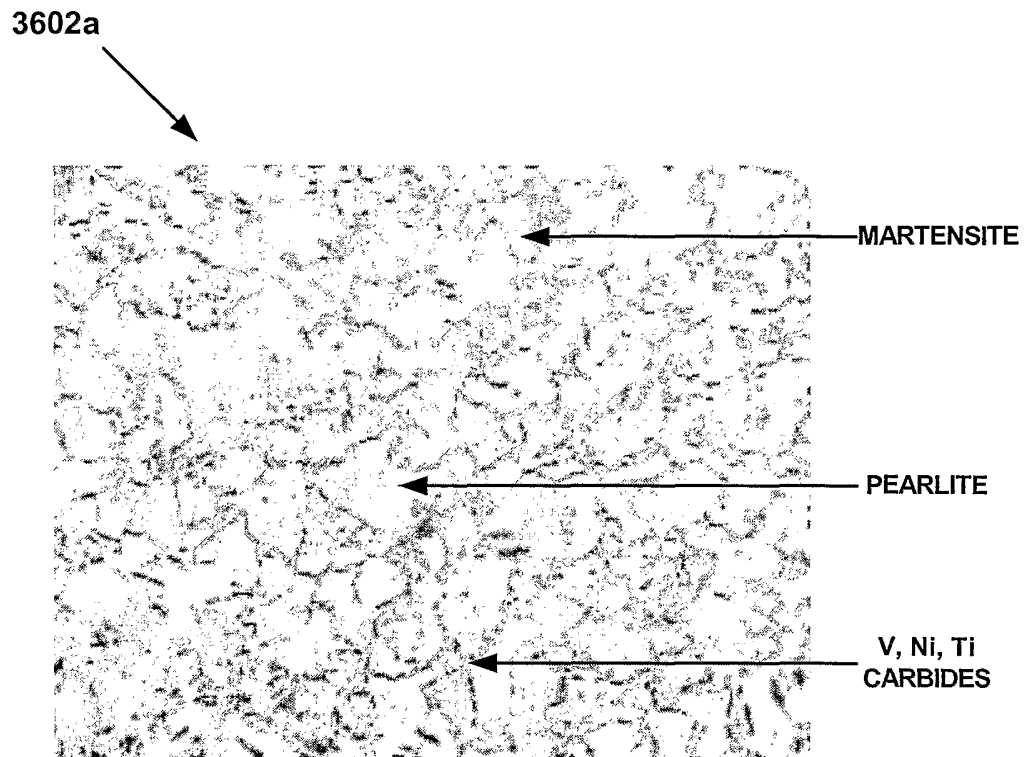

Fig. 36b

3602a

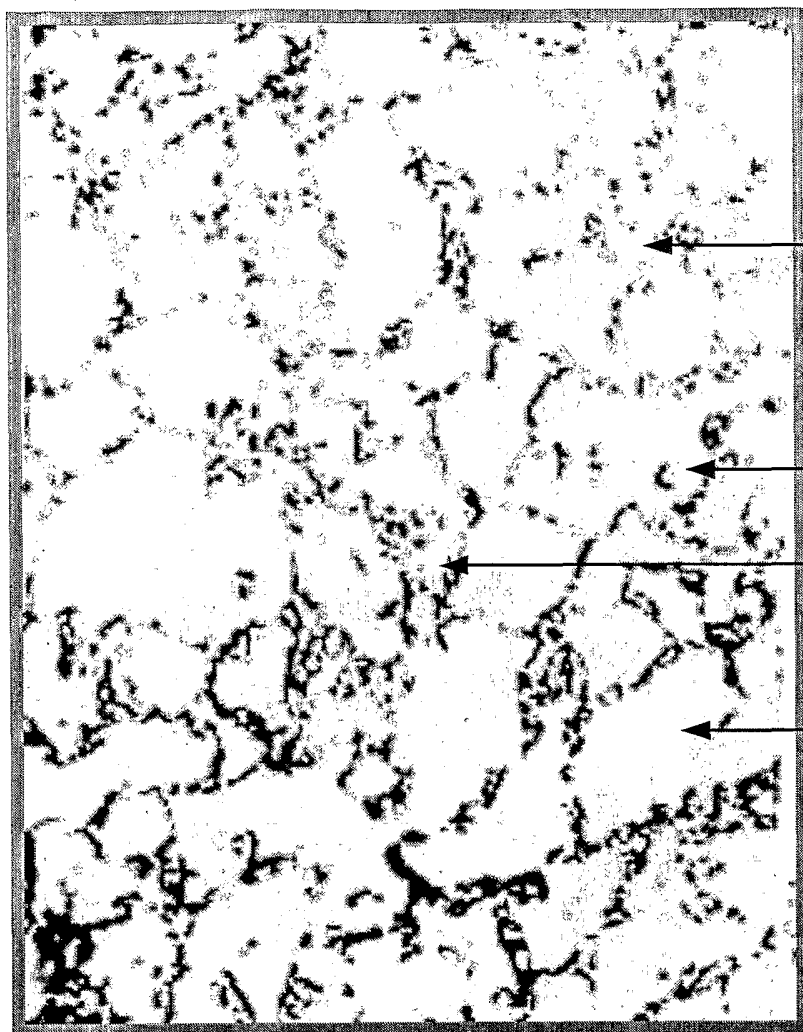

Fig. 36c

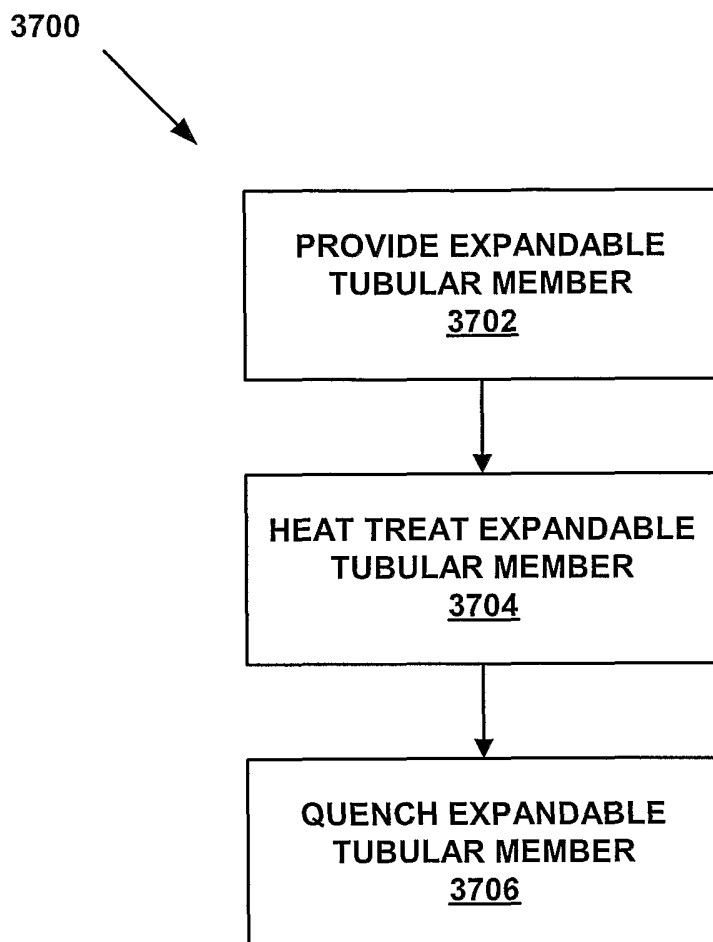

FIG. 37a

3702a

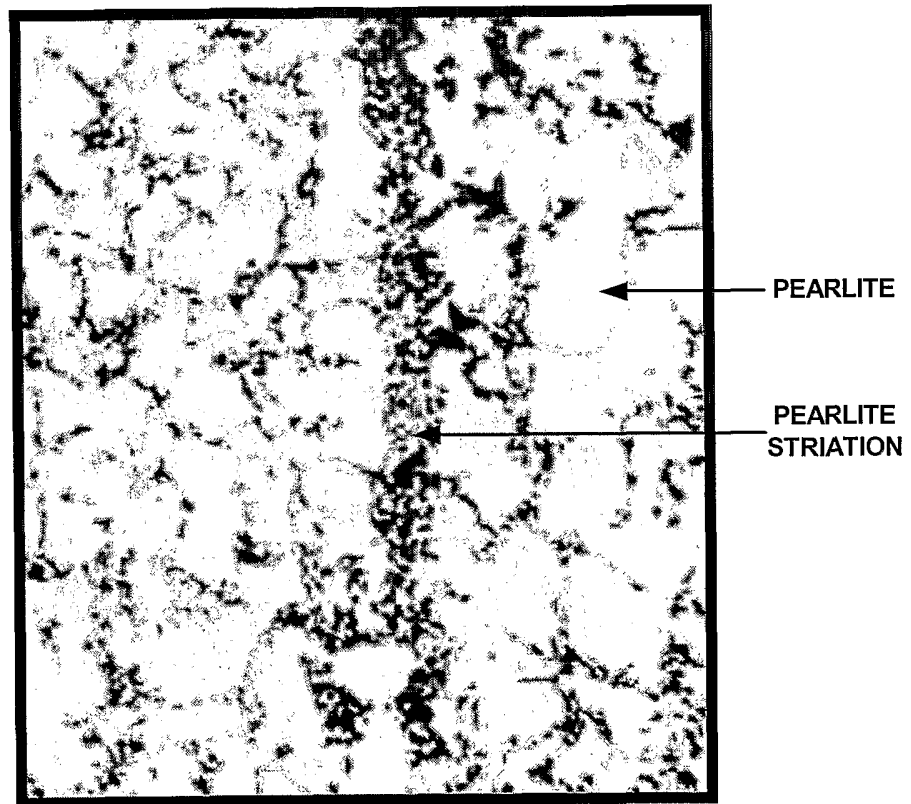

Fig. 37b

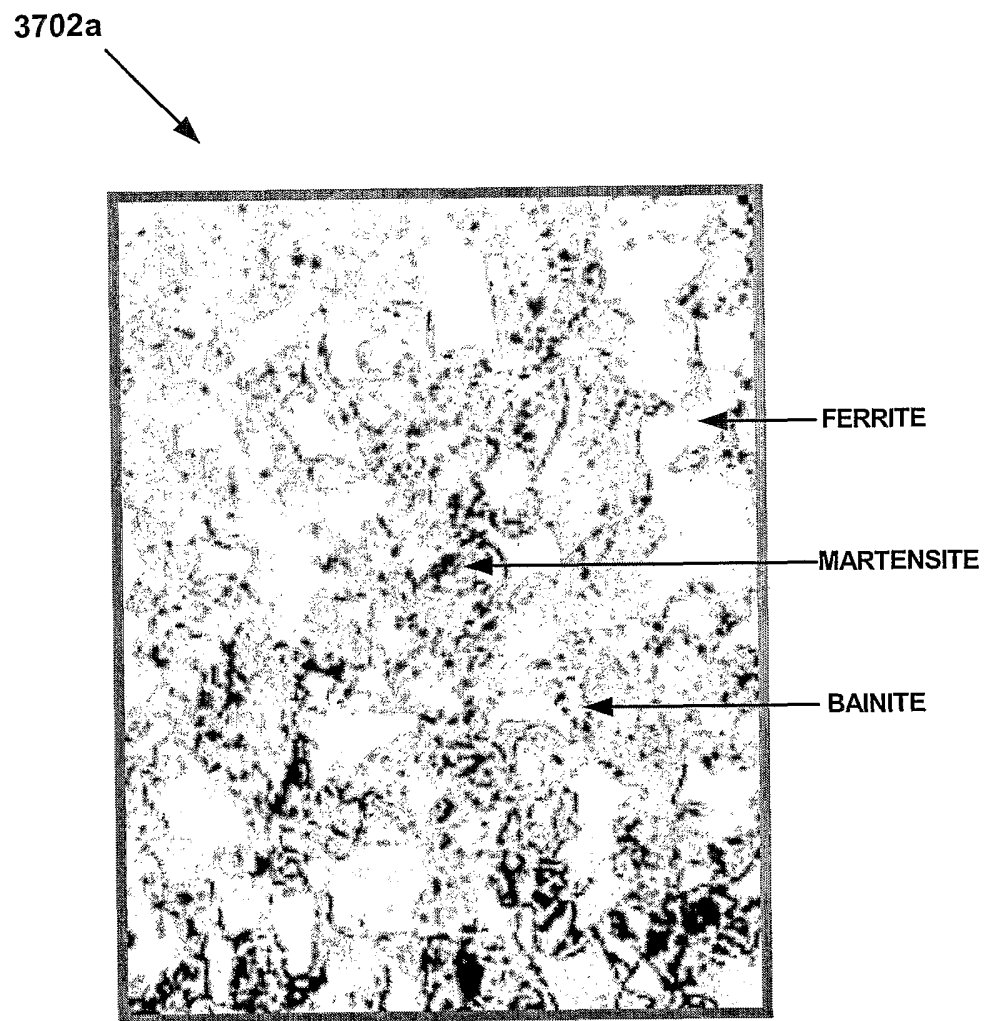

Fig. 37c

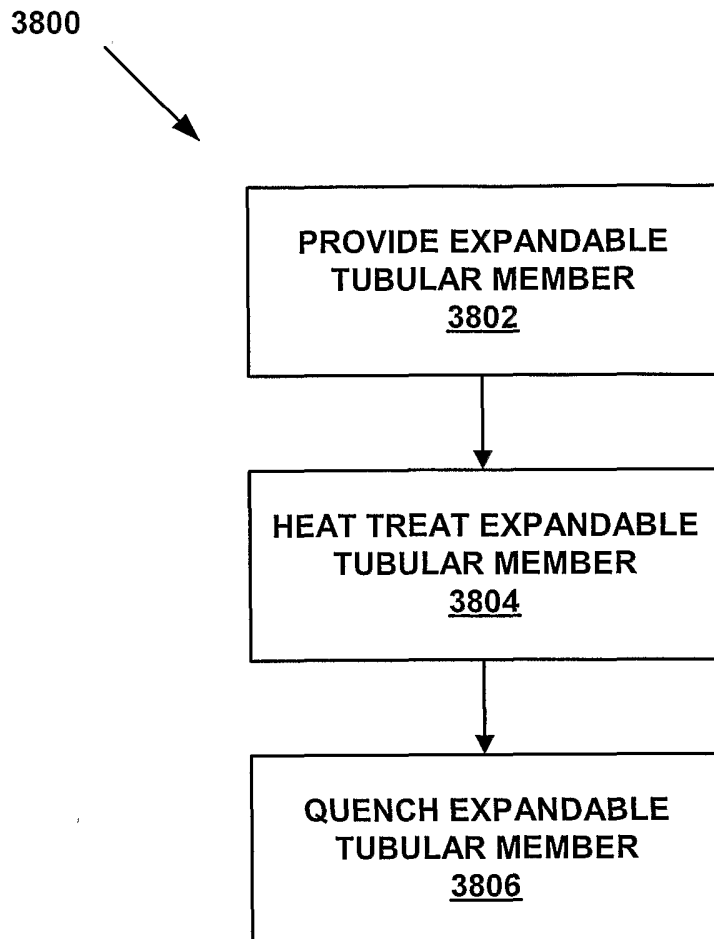

FIG. 38a

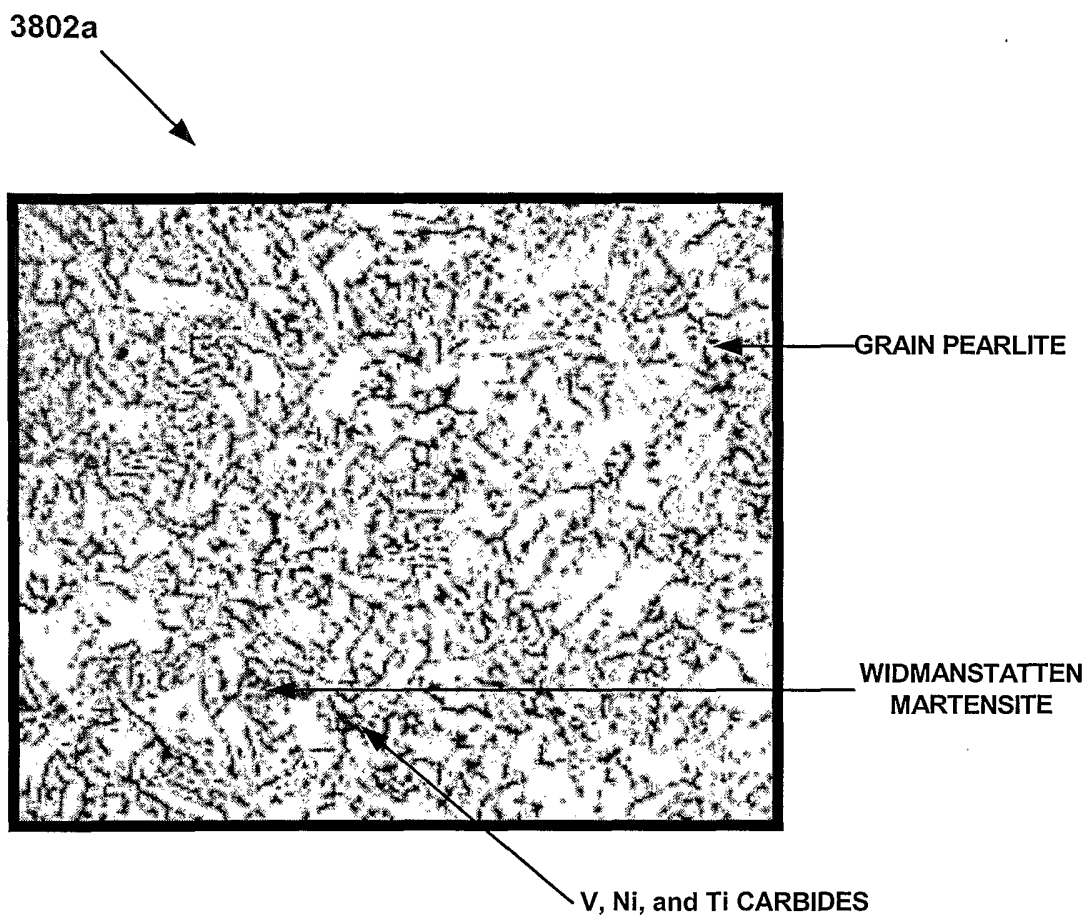
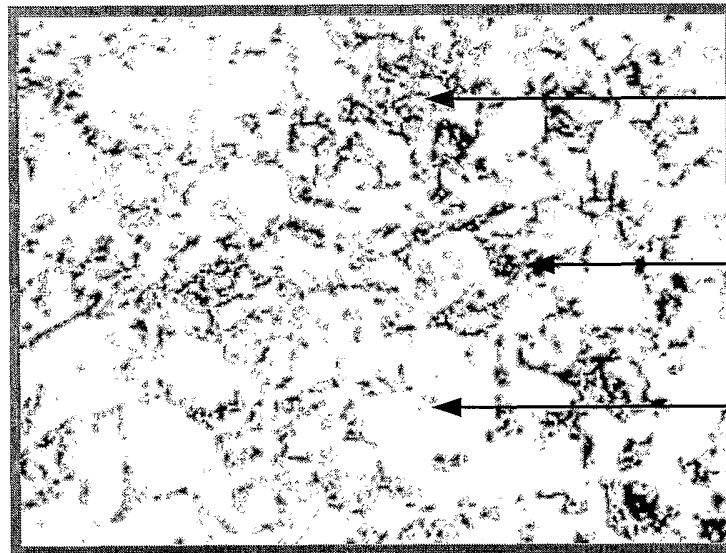

Fig. 38b

3802a



BAINITE

PEARLITE

NEW FERRITE

Fig. 38c