

(19) World Intellectual Property Organization  
International Bureau



(43) International Publication Date  
14 June 2001 (14.06.2001)

PCT

(10) International Publication Number  
WO 01/43467 A1

- (51) International Patent Classification<sup>7</sup>: H04Q 7/24
- (21) International Application Number: PCT/US00/33170
- (22) International Filing Date: 7 December 2000 (07.12.2000)
- (25) Filing Language: English
- (26) Publication Language: English
- (30) Priority Data:  
09/457,624 8 December 1999 (08.12.1999) US
- (71) Applicant: PROXIM, INC. [US/US]; 510 DeGuine Drive, Sunnyvale, CA 94086 (US).
- (72) Inventors: GRAU, Juan; 18 Woodleaf Avenue, Redwood City, CA 94061 (US). REYNOLDS, Russell R.; 950 Oak Ridge Road, Los Gatos, CA 95033 (US). MIM, Reiner; 3475 Granada Avenue, #387, Santa Clara, CA 95051 (US).
- (74) Agent: KREBS, Robert E.; Burns, Doane, Swecker & Mathis, LLP, P.O. Box 1404, Alexandria, VA 22313 (US).

(81) Designated States (national): AE, AG, AL, AM, AT, AU, AZ, BA, BB, BG, BR, BY, BZ, CA, CH, CN, CR, CU, CZ, DE, DK, DM, DZ, EE, ES, FI, GB, GD, GE, GH, GM, HR, HU, ID, IL, IN, IS, JP, KE, KG, KP, KR, KZ, LC, LK, LR, LS, LT, LU, LV, MA, MD, MG, MK, MN, MW, MX, MZ, NO, NZ, PL, PT, RO, RU, SD, SE, SG, SI, SK, SL, TJ, TM, TR, TT, TZ, UA, UG, UZ, VN, YU, ZA, ZW.

(84) Designated States (regional): ARIPO patent (GH, GM, KE, LS, MW, MZ, SD, SL, SZ, TZ, UG, ZW), Eurasian patent (AM, AZ, BY, KG, KZ, MD, RU, TJ, TM), European patent (AT, BE, CH, CY, DE, DK, ES, FI, FR, GB, GR, IE, IT, LU, MC, NL, PT, SE, TR), OAPI patent (BF, BJ, CF, CG, CI, CM, GA, GN, GW, ML, MR, NE, SN, TD, TG).

Published:  
— With international search report.

For two-letter codes and other abbreviations, refer to the "Guidance Notes on Codes and Abbreviations" appearing at the beginning of each regular issue of the PCT Gazette.

(54) Title: FLEXIBLE WIRELESS LAN ARCHITECTURE BASED ON A COMMUNICATION SERVER

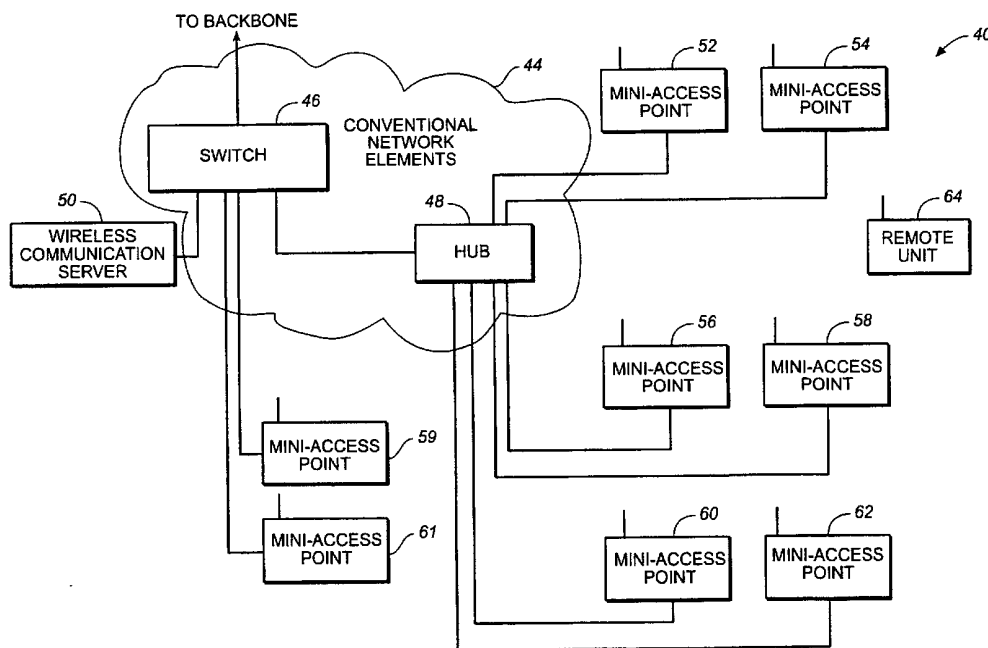

(57) Abstract: A wireless communication server (50) is provided in a wireless LAN system (40). The wireless communication server (50) controls the operation of multiple access points (52, 54, 56, 58-62). In this way, the cost of the access points can be reduced. The wireless communication server provides centralized data traffic filtering, and direction, and other functions.



WO 01/43467 A1

## FLEXIBLE WIRELESS LAN ARCHITECTURE BASED ON A COMMUNICATION SERVER

**BACKGROUND OF THE INVENTION**

5           The present invention relates to wireless Local Area Network (LAN) systems. LANs are typically used to interconnect personal computers or workstations within an office. Computers connected to the LAN communicate among each other and to specialized devices such as file servers and printers.

10           Wired LAN systems can present problems due to wire routing difficulties, installation time and mobility requirements. Wireless LANs have been devised to allow for a wireless interconnection to computer devices and peripherals.

15           Wireless LAN systems can fully replace or extend a wired LAN. In the latter case, access points are typically used to create the interconnection between the wireless and the wired portion of the LAN. Between the remote devices and access points, radio frequency transmissions are typically used. These transmissions are often done using an unlicensed radio frequency band, such as 2.4 GHz - 2.4835 GHz, 5.15 GHz - 5.35 GHz or 5.725 GHz - 5.825 GHz. Relatively weak transmissions on the unlicensed frequency bands are sufficient to communicate between the remote devices and the access points since the wireless LANs are geographically limited.

20

          Although a single access point can support a relatively large group of remote devices, it functions only within a finite range of typically several hundred feet. Extended coverage areas can be accomplished by installing multiple access points with overlapping coverage cells, so that remote devices can roam throughout the area without ever losing network contact. A typical wireless LAN can use up to hundreds of access points, and thus the cost of the access points can strongly influence the cost of the entire system.

25

-2-

Figure 1 illustrates a prior art system for a wireless LAN using access points. A backbone 21 comprising conventional network elements such as hubs and switches is connected to the access points 26 and 28. Data coming from devices such as file server 25 on the backbone 21 goes to the access points 26 and 28. The correct access point then transmits the data to the desired remote unit 34 or 35. Such a wireless LAN arrangement requires a relatively complex and expensive access point, since many functions are duplicated in all of the access points.

In order to provide transparent connectivity between the computers on the wired LAN and the remote units, an access point processes all packets on its backbone interface. Access points usually look at the destination address of each data packet, and consult internal tables to determine whether the packet should be received and forwarded out its wireless interface. Data that is not forwarded is, in effect, filtered out. As fast data backbones such as 100Mbit Fast Ethernet become more common, the ability to process and filter data packets at the appropriate wire speed requires a relatively complex access point. This is despite the fact that the access point's effective throughput may remain limited by the slower wireless link connection.

Other operations typically placed in the access points, such as management and security functions, further drive up the memory size and processing power requirements of the access points. Typically, a security table is stored in each access point indicating the remote units which are authorized to transmit data through to the LAN. Since many table entries (and a variety of other data) are typically duplicated on each access point, some of the electronics in the access points is utilized inefficiently, further driving up the total cost of the wireless infrastructure.

The majority of access points on the market today are fixed-configuration single-radio systems. Another type of prior art system is based on modular multi-

-3-

slot access points. Multi-slot access points use multiple radio card slots that allow for multiple radio transceivers. The use of more than one radio transceiver can increase the access point's bandwidth or provide increased radio flexibility. In particular, since multi-slot access points are modular, the transceiver units can be  
5 upgraded with future technology allowing for higher data rates. Unfortunately different transceiver unit implementations vary widely not only in terms of performance, but also coverage range. To compensate for the significant range loss that usually ensues with a higher data rate transceiver, additional access points need to be installed to avoid coverage holes. In most cases, a completely new site  
10 survey will be required to determine the ideal location of both the additional and the existing access points. The other downside of the modular multi-slot access points is that they tend to be bulky and expensive. In many cases, the access points' locations for optimal wireless LAN coverage are in areas that are hard to reach, such as roof rafters. To allow for maintenance of these complex access  
15 points, they are typically placed in an easy to reach location and a coaxial antenna cable is used to connect the respective antenna to the access point. This allows the antenna to be placed in the optimal - but hard to access - location while minimizing maintenance concerns. Due to the close proximity of the individual radio transceivers in a multi-slot access point, it may be necessary to install external  
20 antennas with additional separation between the antennas to avoid undesired interference effects, even if the access point itself can be positioned in the ideal location. In both cases, expensive, stiff, and relatively uncommon co-axial antenna cable extensions are required.

#### SUMMARY OF THE PRESENT INVENTION

25 The present invention, in one embodiment, comprises a wireless LAN system including a wireless communication server and one or more access points operably connected to the wireless communication server. The access points are

adapted to wirelessly transmit and receive data to and from remote units using radio frequency communications such that the remote units form part of a wireless LAN. The wireless communication server is physically separate from the access points. The wireless communication server maintains centralized filtering and forwarding of data to be transmitted to the remote units.

In another embodiment the present invention comprises a method of directing data to a remote unit in a wireless LAN. In a wireless communication server, network data is analyzed to determine, from a remote unit identification, a desired access point to transmit the data. The wireless communication server is adapted to select the desired access point from a number of possible access points. In the wireless communication server, the data is redirected to the correct access point. In an access point, data is wirelessly transmitted to the remote unit using a radio frequency communication link. The wireless communication server is physically separate from the access point.

#### **BRIEF DESCRIPTION OF THE DRAWINGS**

Figure 1 is a diagram of a prior art wireless LAN system.

Figure 2 is a diagram illustrating one embodiment of a wireless communication server and mini-access points connected to a wired LAN backbone.

Figure 3 is a diagram of the wireless LAN system of one embodiment of the present invention.

Figure 4 is a diagram that illustrates the operation of data transfer between the external network and a remote unit in one embodiment of the present invention.

Figure 5 is a diagram of one embodiment of a wireless communication server connected to access points through dedicated connection elements.

-5-

Figure 6 is a diagram of one embodiment of a wireless communication server directly connected to access points (built-in hub).

Figure 7 is a diagram illustrating a wireless communication server of one embodiment of the present invention.

5 Figure 8 is a diagram illustrating a mini-access point of one embodiment of the present invention.

Figure 9 is a diagram illustrating a wireless LAN system of one embodiment of the present invention connected to use multiple wireless communication servers as backup systems or to achieve higher mini-access point  
10 densities.

## DETAILED DESCRIPTION OF THE PREFERRED EMBODIMENT

### Overview

One embodiment of the present invention is a wireless LAN architecture where functionality previously provided by a single prior art access point device is  
15 divided into two separate devices. The first device is an apparatus with the main purpose to convert the wired medium information into a wireless medium. This device is called an access point (or mini-access point) and it converts information between the wired Ethernet medium and a radio frequency medium, although other  
wired and wireless media options are possible. The second device performs most  
20 of the networking functions, including certain processing-intensive functions commonly placed into access points in prior art wireless LAN systems. In a preferred embodiment of this invention, this device is called a wireless communication server. The core functions of the wireless communication server are the centralized filtering of unnecessary data and the forwarding of the relevant  
25 data to the correct mini-access point. Additional functions that can be placed in the

wireless communication server include mini-access point management, security, quality of service (QoS), load balancing, and others.

Generally speaking, the wireless communication server centralizes in one device certain common functions found in multiple access points in prior art, 5 freeing one or multiple mini-access points from having to perform these functions. A relatively large number of the mini-access points can be controlled by a single wireless communication server. This way, the hardware and software necessary to perform these functions no longer needs to be duplicated in all the access points of an installation. Consequently, the use of a wireless communication server allows 10 for the mini-access points to be made less complex, less power consumptive, and smaller, significantly reducing the total system cost. The reduced power consumption of the mini-access points makes it possible to supply DC power to the mini-access points remotely over a few of the wires of a data wire bundle. Eliminating the AC power outlet dependency combined with its reduced form 15 factor allows the mini-access point to be positioned at the optimal location for the antenna, removing the need for an additional co-axial antenna extension.

The mini-access point and the wireless communication server are typically physically connected together by an interconnection system comprised of conventional network elements such as hubs, switches, routers, and the like. 20 Some of these elements, such as hubs, can be integrated into the wireless communication server, or alternatively, external network elements can be leveraged. In a preferred embodiment, the wireless communication server can be implemented as a cost-effective single-port solution that connects to a backbone. The mini-access points may also be connected to the backbone, or to the wireless 25 communication server via a dedicated LAN segment. The existing conventional wired network elements provide a two-way communications path between the mini-access points and the wireless communication server and between the wireless communication server and the backbone. The interconnection system can also use

a variety of physical media standards such as Ethernet, Fast Ethernet, Asynchronous Transfer Mode (ATM), Fiber Distributed Data Interface (FDDI), Token-Ring, and other present and future local area physical and link layer standards. By leveraging industry-standard interconnection components,  
5 installation complexity can be greatly reduced.

The wireless communication server logically communicates with the mini-access points via standard data networking protocols. Information exchanged between the wireless communication server and the mini-access points can be categorized as management information or data information. Management  
10 information is information generated at either the wireless communication server or the mini-access point and destined to either the wireless communication server or mini-access points. Data information is information generated elsewhere in the network, passing through the wireless communication server and eventually a mini-access point and destined to devices elsewhere in the network. Data  
15 information travelling between the wireless communication server and the mini-access point may, for example, be encapsulated in Transmission Control Protocol/Internet Protocol (TCP/IP) or Sub-Network Access Protocol/ Service Access Point (SNAP/SAP) frames. This alleviates the need for expensive filtering functionality on the mini-access points. Also, using standards-based transport mechanisms  
20 allows management or data information to flow through a wide range of standards-based interconnection systems. Once again, this greatly reduces the complexity of the installation process as well as its cost since the interconnection system is usually already in place in many installations or is readily available from a wide range of component suppliers.

25 In a preferred embodiment, the wireless communication server monitors all the data information passing through the network. If it determines that some of the data is destined to a device on the wireless network, it will receive such data and re-transmit it directly to the most appropriate mini-access point. That mini-access



-8-

point will then convert the data to the wireless medium and deliver it to the destination device. Data that is not directed to the wireless network is filtered out by the wireless communication server. In a preferred embodiment, the mini-access point is only required to receive data or management information directed to it. It is not required to monitor the wired network for data destined to other devices on the wireless or wired network. On the other hand, data transmitted by a wireless device will be received by the most appropriate mini-access point which will convert the data to the wired medium and direct it to the wireless communication server. Once again, it is not required that the mini-access point examines the data to determine where to send it. In this preferred embodiment, the mini-access point will always send this data to the wireless communication server. The wireless communication server will then receive that data from the mini-access point and forward it to the proper destination.

As stated above, in a preferred embodiment of the present invention the filtering is done in a centralized manner in the wireless communication server. The wireless communication server examines the data on the network for data to be sent to a remote unit. The filtering in the wireless communication server is preferably done based on a remote unit identification. In a preferred embodiment, the layer 2 (data link layer) address of the remote unit is used as the remote unit identification.

The data for the remote unit is forwarded to the correct mini-access point. In one embodiment, the data is encapsulated in a frame that adds the correct mini-access point address to the data. The mini-access point wirelessly transmits the forwarded data to the remote unit without needing to examine the data for a remote unit identification. Although different remote units are associated with the mini-access point at different times, the mini-access point needs only look for the unchanging mini-access point address in the frame encapsulating the data. The

filtering function is thus centralized in the wireless communication server rather than at the mini-access points.

Typically, a wireless communication server is first installed by connecting it to the existing LAN infrastructure. Then mini-access points are added by also  
5 connecting them to the LAN infrastructure. In a preferred embodiment, the wireless communication server automatically detects the appearance of a mini-access point on the network and takes control over it. However, it is also possible to first deploy mini-access points, and to install the wireless communication server at a later time. Once installed, the wireless communication server can discover  
10 mini-access points present on the network and take control over them. In a preferred embodiment, the process of taking control minimally encompasses forcing all or most data traffic to and from the mini-access point to come from the wireless communication server, or to be directed to the wireless communication server. In addition, management information for the mini-access point would  
15 come from or go to the wireless communication server.

Multiple wireless communication servers can preferably be operational on a wireless LAN at the same time. In a preferred embodiment, a mechanism exists to allow one wireless communication server to back-up another and to take over in a failure situation.

Another aspect of the wireless communication server is to provide a  
20 platform that allows the integration of multiple different wireless media technologies, for example complying with different vendors' wireless media standards, into a unified wireless network. By centralizing most of the networking and management features, it is possible to have mini-access points with different  
25 wireless media capabilities attached to a single wireless communication server. For example, there could be one particular area of an installation using applications that require higher data rates. It would then be possible to install higher performance, but more costly mini-access points on an as-needed basis

-10-

only, and allow these to share a wireless communication server with any existing, legacy performance mini-access points. Other than the data rate differences, in a preferred embodiment the user would see equivalent functionality from the legacy and the high performance mini-access point. This is because most of the

5 intelligence functions reside in the wireless communication server. Such an integration provides a great benefit to network administrators by allowing them to maintain one common look and feel of the wireless network, regardless of the type of mini-access point and wireless media standard used. Furthermore, it makes it easy for users to expand the wireless network with additional mini-access points

10 without requiring special training and lengthy qualification, which is again due to the fact that most of the relevant functionality – from a network administrators perspective – resides in the wireless communication server. Because of these characteristics, the present invention also provides a clean and simple migration path from the wireless media technologies of today to new, potentially more

15 powerful wireless media technologies of tomorrow. The user can simply add mini-access points to those areas where the new technology is desired, while leaving the existing legacy mini-access points in operation and without disrupting the existing wireless network.

Figure 2 is a diagram illustrating a wireless communication server 110, and

20 mini-access points 118 and 120 connected to a wired backbone 112. The LAN backbone 112 may include hubs, switches and the like. Also shown are file server 114, personal computer 116, and printer 119. The wireless communication server 110 and mini-access points, 118 and 120, can be placed anywhere on the wired LAN backbone. The example of Fig. 2 uses a single-port wireless

25 communication server in which the wireless communication server 110 both receives data from the wired infrastructure and sends data to the mini-access points using the same port.

-11-

Figure 3 illustrates a wireless LAN system 40 of the present invention. Conventional network elements 44, which in this example include switch 46 and hub 48, connect to a LAN backbone. A variety of conventional wired network elements can be used with the present invention. Typically, these wired network elements are OSI model level 3 or below. The wireless communication server 50 is connected to these conventional network elements 44. Mini-access points 52, 54, 56, 58, 59, 60, 61 and 62 are also connected to the conventional network elements. A remote unit such as remote unit 64 can wirelessly communicate with the mini-access points. As described in Figure 4 below, data from the backbone is sent to the switch 46, which directs all data traffic destined for the remote units to the wireless communication server 50. The wireless communication server 50 uses a destination table to determine which mini-access point the desired remote unit is associated with, and then redirects the data to that mini-access point. In this embodiment, the data is sent from the wireless communication server 50 to the switch 46, hub 48 and the mini-access point. The mini-access point can then transmit the data to the remote unit without requiring a table lookup to determine whether to forward the data. Since the mini-access point does not need to process a table, its complexity is reduced significantly. The wireless communication server 50 preferably also contains the security tables for the system since all the data coming to and from the remote units is sent to the wireless communication server.

One manner of forwarding the data by the wireless communication server is by repackaging the data (frame encapsulation). Alternately, frame translation or any other redirecting method can be used.

The conventional wired network elements 44 allow for great flexibility in connecting a relatively large number of mini-access points to the wireless communication server, as well as for the setting up of additional wireless communication servers.

-12-

Note that the system in Figure 3 can be arranged such that the connection to the mini-access point is done at a lower connection speed than the connection to the wireless communication server. This allows for an even less expensive wireless access point.

5           Figure 4 illustrates a diagram showing an example of the data transfer for one embodiment of the system of Figure 2. Data coming from the backbone is sent to the conventional network devices. The data is sent from the switch 46' to the wireless communication server 50'. The wireless communication server 50' processes the incoming packet. The wireless communication server 50' examines  
10 the remote unit address and determines whether to forward or filter the packet. If the packet is to be forwarded, it determines from the remote unit address the correct mini-access point to be sent the data. In one embodiment, the data is repackaged to be transmitted to the mini-access point. The data is sent from the wireless communication server 50' to the switch 46' to the hub 48' and then data is  
15 propagated by the hub 48' to all of the mini-access points 52', 54', 56' and 58'. The mini-access points examine the redirected packet data for the mini-access point address. The mini-access point address is fixed for each mini-access point so this check does not require a table look-up. The mini-access point then transmits the data to the remote unit using a conventional wireless protocol. The remote unit 64  
20 receives the data from the mini-access point. Data can be sent back to the backbone by transmitting from the remote unit to the mini-access point, hub 48', switch 46', to the wireless communication server 50'. If so, the wireless communication server 50' checks to see whether the data should be transmitted to the wired network or to another remote unit. If the data is destined for the wired  
25 network, it then transmits the data to the switch 46', and from there to the backbone. If the data is destined to a remote unit, it repackages the data and sends it to the appropriate mini-access point.

-13-

Figure 5 is a diagram of a wireless communication server 122 connected by using dedicated connection elements 124 to mini-access points 126, 128 and 130. The wireless communication server 122 is connected to the wired infrastructure along line 132. The dedicated connection elements 124 may be conventional connection elements including switches, hubs and the like or they can be specially designed connecting units. The example of Fig. 5 uses a two-port wireless communication server in which data is received from a wired infrastructure using one port and data sent to the mini-access points using another port.

Figure 6 is a diagram of a wireless communication server 134 directly connected to mini-access points 136, 138 and 140. The wireless communication server 134 is a multi-port wireless communication server in which more than one port is used to connect to the mini-access points. The wireless communication server 134 has an internal, built-in hub or switch that allows this multiple port connection system.

One advantage of the system of Figs. 5 and 6 is, that in those systems the wireless communication server can supply power to the mini-access points using otherwise unused wires in the data wire bundle between the wireless communication server and the mini-access points. This arrangement helps in positioning the mini-access point to create optimum wireless coverage independent of the availability of AC power sockets.

Figure 7 illustrates a diagram of one embodiment of a wireless communication server 90 for use with the present invention. Port 92 is connected to a network interface 94. Network interface 94 loads data into and from buffer 96. The processor 98 uses instructions stored in memory 100 to control the packet processing operations. The memory 100 stores the functional library code for doing the core functions (filtering and data redirecting) as well as any optional implemented functions (security, QoS, load balancing, access point management). The optional network management interface code allows for user control and

configuration of the wireless communication server using a Web server, Simple Network Management Protocol (SNMP), a serial controller protocol or other protocol. A system state memory section in memory 100 stores the required network state information, such as destination tables, authorization and security tables and the like.

The wireless communication server of Figure 7 shows a single network port 92. A multi-port wireless communication server can be produced by adding a built-in hub to the wireless communication server.

Figure 8 illustrates a diagram of one embodiment of a mini-access point of the present invention. A LAN controller 102 is connected to a radio 104, central processing unit (CPU) 108, and memory 109. A relatively inexpensive CPU 108 connected to a relatively small memory 109 can do the reduced functions of the mini-access point. These functions can include checking the data packets to see if the data packet addresses the mini-access point for transmission; the wireless communication server auto-detect function and the reduced-function stand-alone operation. The CPU need not be able to do the computationally intense filtering operations using a destination table that stores which remote units are associated with the mini-access point.

One important advantage of the system of Figs. 7 and 8 is, that in a preferred embodiment the wireless communication server can support a mix of mini-access points with different types of radios 104. Since the mini-access point controls the wireless protocol, the wireless communication server can be flexible enough to allow future upgrades of the wireless infrastructure to higher data rate radio technology. Furthermore, the flexibility provided by the conventional interconnection system allows to create a new high data rate capable infrastructure in a design specifically suited to the range of the high data rate transceiver units and antennas.

-15-

Figure 9 illustrates a wireless LAN of the present invention using multiple wireless communication servers 212, 214, and 216. These wireless communication servers can receive duplicate data from the system such that each wireless communication server stores the destination and security tables for the entire system. Each wireless communication server is responsible for a subset of the mini-access points. For example, wireless communication server 212 is responsible for mini-access points 218 and 220 and wireless communication server 214 is responsible for mini-access points 222 and 224. If one of the wireless communication servers such as wireless communication server 214 fails, another wireless communication server, such as wireless communication server 212 can take over responsibility for the transmitting of data to and from the mini-access points 222 and 224. The arrangement of Figure 9 with multiple wireless communication servers connected into the conventional network allows for an easy duplication of the functions of the wireless communication server. By using a backup wireless communication server, the reliability of the entire system is improved.

It will be appreciated by those of ordinary skill in the art that the invention can be implemented in other specific forms without departing from the spirit or central character thereof. For example, the conventional wire protocol can be Ethernet, Fast Ethernet, Gigabit Ethernet, Token Ring, ATM or any other conventional network protocol including other IEEE 802 standards. The wired network can also use converters which can convert the wired protocol during signaling between the wired communication server and the mini-access point. The presently disclosed embodiments are therefore considered in all respects to be illustrative and not restrictive. The scope of the invention is illustrated by the appended claims rather than the foregoing description, and all changes which come within the meaning and range for equivalence thereof are intended to be embraced herein.



Claims:

1. A wireless Local Area Network system comprising:  
a wireless communication server; and  
one or more access points operably connected to the wireless  
5 communication server, the access points adapted to wirelessly transmit and receive  
data to and from remote units using a radio frequency communications such that  
the remote units form part of a wireless Local Area Network, wherein the wireless  
communication server is physically separate from the access points, the wireless  
communication server maintaining centralized filtering and forwarding of data to  
10 be transmitted to the remote units.
2. The wireless Local Area Network system of Claim 1 wherein the  
wireless communication server is connected through conventional network  
elements to the access points.
3. The wireless Local Area Network system of Claim 1 wherein the  
15 wireless communication server and the one or multiple access points are connected  
to an existing wired network.
4. The wireless Local Area Network system of Claim 3 wherein the  
existing wired network is an Ethernet network or a network that adheres to other  
IEEE 802 standards.
- 20 5. The wireless Local Area Network system of Claim 2 wherein at  
least one network element includes a hub.
6. The wireless Local Area Network system of Claim 2 wherein the at  
least one network element includes a switch.

-17-

7. The wireless Local Area Network system of Claim 2 wherein the at least one network element includes a router.

8. The wireless Local Area Network system of Claim 1 wherein the wireless communication server is connected to the one or multiple access points through a direct cable connection.

9. The wireless Local Area Network system of Claim 1 wherein the wireless communication server has a built-in interconnection unit to allow for multiple ports to connect to the multiple access points.

10. The wireless Local Area Network system of Claim 1, wherein the wireless communication server is adapted to provide a centralized security system for the access points.

11. The wireless Local Area Network system of Claim 1, wherein the wireless communication server acts as a centralized management system for the access points.

12. The wireless Local Area Network system of Claim 1, wherein the wireless communication server can concurrently operate with multiple access points utilizing different wireless media types and/or data rates.

13. The wireless Local Area Network system of Claim 1, wherein the access points are adapted to provide some data filtering and forwarding upon failure of the wireless communication server.

-18-

14. The wireless Local Area Network system of Claim 1, wherein the wireless communication server includes one or multiple security tables.

15. The wireless Local Area Network system of Claim 1, wherein the wireless communication server includes at least one destination table relating  
5 remote units to access points.

16. The wireless Local Area Network system of Claim 15, wherein a centralized management system maintains the destination table or tables.

17. The wireless Local Area Network system of Claim 1, wherein the wireless communication server forwards data to the access points using frame  
10 translation or encapsulation.

18. The wireless Local Area Network system of Claim 1, wherein the at least one access point comprises a mini-access point.

19. The wireless Local Area Network system of Claim 1, wherein the  
15 access points are powered by the wireless communication server or a dedicated device such as a power hub through at least two wires in a data-wire bundle.

20. The wireless Local Area Network system of Claim 1 further comprising at least one additional wireless communication server.

21. The wireless Local Area Network system of Claim 20, wherein said  
20 at least one additional wireless communication server provides services for additional access points.

22. The wireless Local Area Network system of Claim 20, wherein the at least one additional wireless communication server acts as a backup for the first wireless communication server.

5 23. The wireless Local Area Network system of Claim 1, wherein the wireless communication server has a single data transfer port which connects the wireless communication server to at least one network element.

24. The wireless Local Area Network system of Claim 1, wherein at least one network element provides a path excluding the wireless communication server between the external network and the access point.

10 25. The wireless Local Area Network system of Claim 1, wherein the access points transmit the radio frequency wireless signals using an unlicensed frequency band.

15 26. The wireless Local Area Network system of Claim 1, wherein the system provides the automatic association of the access points and the wireless communication server.

27. The wireless Local Area Network system of Claim 1, wherein the wireless communication server filters network data based on a remote unit identification.

20 28. The wireless Local Area Network system of Claim 27, wherein the remote unit identification is a level 2 layer address of the remote unit.

-20-

29. A wireless Local Area Network system comprising:

at least one wired-network element;

a wireless communication server operably connected to the  
at least one wired-network element; and

5 one or multiple access points operably connected to the  
wireless communication server through the wired-network element, the access  
points adapted to wirelessly transmit and receive data to and from remote units  
using a radio frequency communications such that the remote units form part of a  
wireless Local Area Network, wherein the wireless communication server is  
10 physically separate from the access points, the wireless communication server  
maintaining centralized filtering and forwarding of data to be transmitted to the  
remote units.

30. The wireless Local Area Network system of Claim 29, wherein the  
wireless communication server acts as a centralized security system for the access  
15 points.

31. The wireless Local Area Network system of Claim 29, wherein the  
wireless communication server acts as a centralized management system for the  
access points.

32. The wireless Local Area Network system of Claim 29, wherein the  
20 wireless communication server can concurrently operate with multiple access  
points utilizing different wireless media types and/or data rates.

33. The wireless Local Area Network system of Claim 29 further  
comprising at least one additional wireless communication server.

34. The wireless Local Area Network system of Claim 29, wherein at least one network element includes a hub.

35. The wireless Local Area Network system of Claim 29, wherein at least one network element includes a switch.

5 36. The wireless Local Area Network system of Claim 29, wherein at least one network element includes a router.

37. A wireless Local Area Network system comprising:  
a wireless communication server; and  
one or more access points functionally connected to the  
10 wireless communication server, the access points adapted to wirelessly transmit  
and receive data to and from remote units using a radio frequency communications  
such that the remote units form part of a wireless Local Area Network, wherein  
the wireless communication server is physically separate from the access points,  
the wireless communication server maintaining at least one centralized function for  
15 the one or more access points.

38. The wireless communication system of claim 37, wherein the at least one centralized function includes the centralized filtering and forwarding of data to be transmitted to the remote units.

39. The wireless communication system of claim 37, wherein the at least  
20 one centralized function includes centralized network management for the access  
points.

-22-

40. The wireless communication system of claim 37, wherein the at least one centralized function includes centralized authorization services for the access points.

5 41. The wireless communication system of claim 37, wherein the at least one centralized function includes centralized security services for the access points.

42. A wireless Local Area Network system comprising:  
a wireless communication server; and  
two or more access points operably connected to the wireless communication server, the access points adapted to wirelessly transmit and receive  
10 data to and from remote units using a radio frequency communications such that the remote units form part of a wireless Local Area Network, wherein the wireless communication server is physically separate from the access points, the wireless communication server maintaining centralized filtering and forwarding of data to be transmitted to the remote units.

15 43. The wireless Local Area Network system of Claim 1 wherein the wireless communication server is operably connected through conventional network elements to the access points.

-23-

44. A method of directing data to a remote unit in a wireless Local Area Network using access points and remote units, comprising:

5 in a wireless communication server which is physically separate from the access point, analyzing network data to determine, from a remote unit identification, a desired access point to transmit the data, the wireless communication server being adapted to select the desired access point from a number of possible access points;

10 in the wireless communication server, forwarding the data to the correct access point;

in an access point, wirelessly transmitting the data to the remote unit using a radio frequency communication link, wherein the network data is filtered by the wireless communication server such that the access point needs not examine the remote unit identification to determine whether to transmit the data.

45. The method of Claim 44 further comprising the step of, in the wireless communication server, examining the data to determine whether the remote unit is authorized to receive data from the Local Area Network.

46. The method of Claim 44 further comprising, in the access point, sensing whether a wireless communication server is associated with the network.

47. The method of Claim 44 further comprising, in the wireless communication server, sensing whether an access point is associated with the network.

48. The method of Claim 44 wherein the wireless communication server uses a destination table to associate a remote unit with an access point.



-24-

49. The method of Claim 44 wherein the forwarding step comprises frame translation or encapsulation.

50. The method of Claim 44 further comprising providing at least one additional wireless communication server.

5 51. The method of Claim 50 wherein the at least one additional wireless communication server is associated with additional access points.

52. The method of Claim 50, wherein the at least one additional wireless communication server takes control for the access points upon failure of the first wireless communication server.

10 53. The method of Claim 44, further comprising transmitting data from the remote unit to the access point, from the access point to the wireless communication server and from the wireless communication server to the external network.

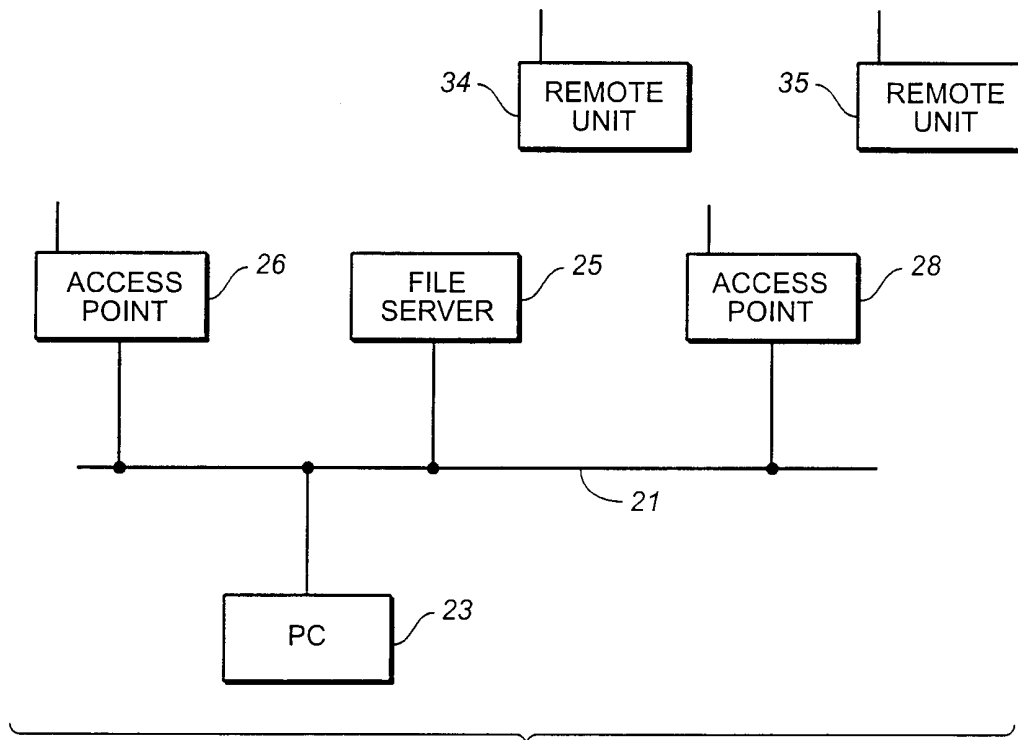

**FIG.\_1**  
(PRIOR ART)

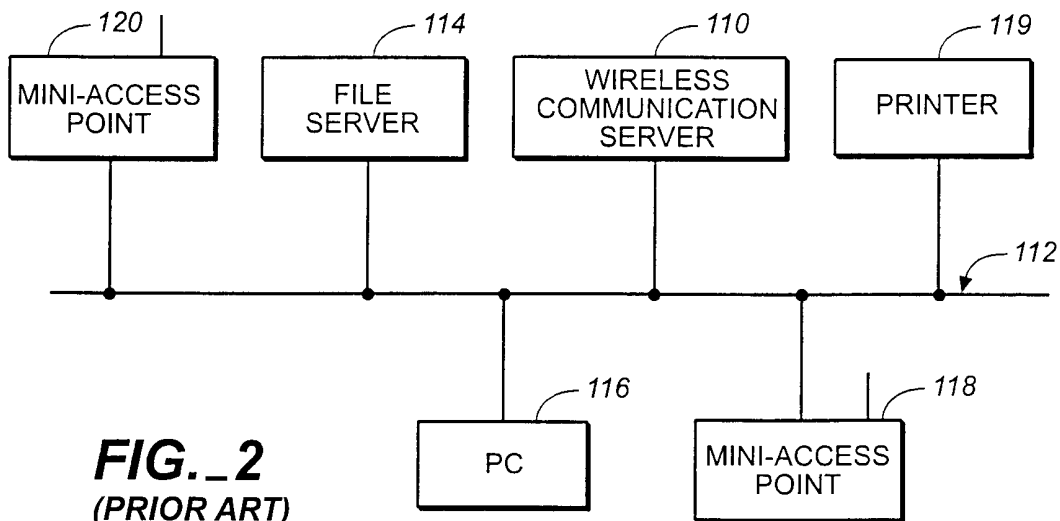

**FIG.\_2**  
(PRIOR ART)

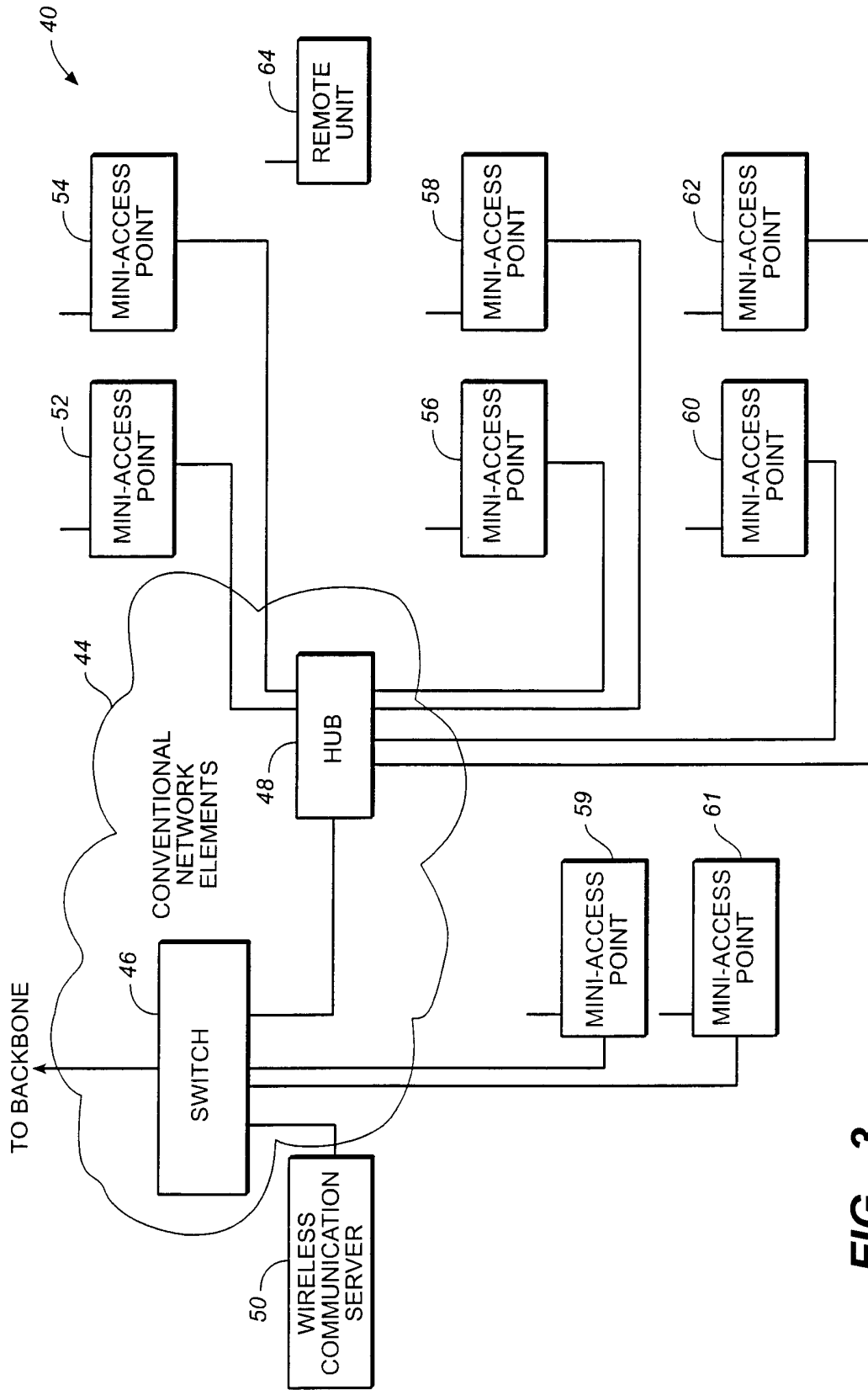
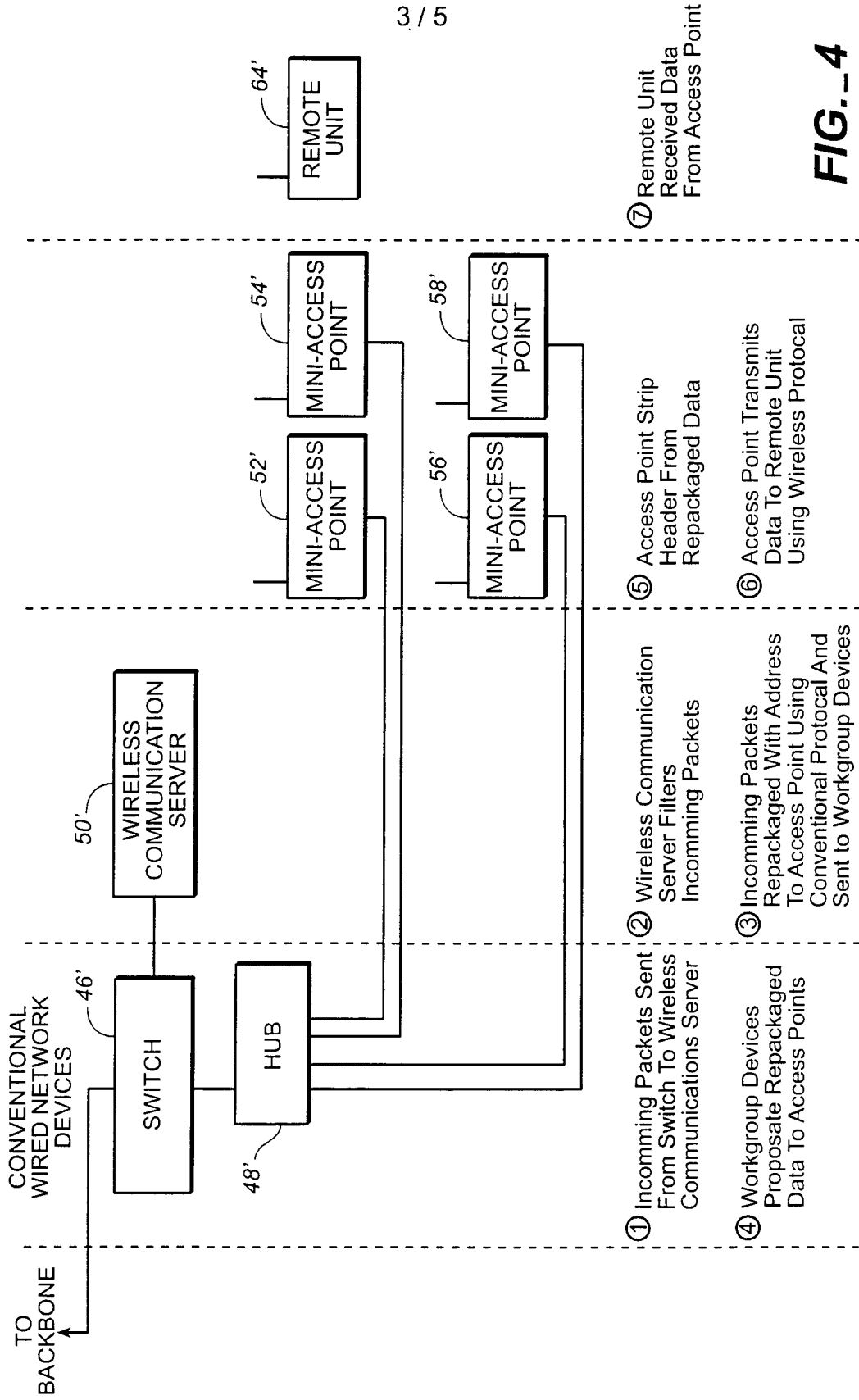
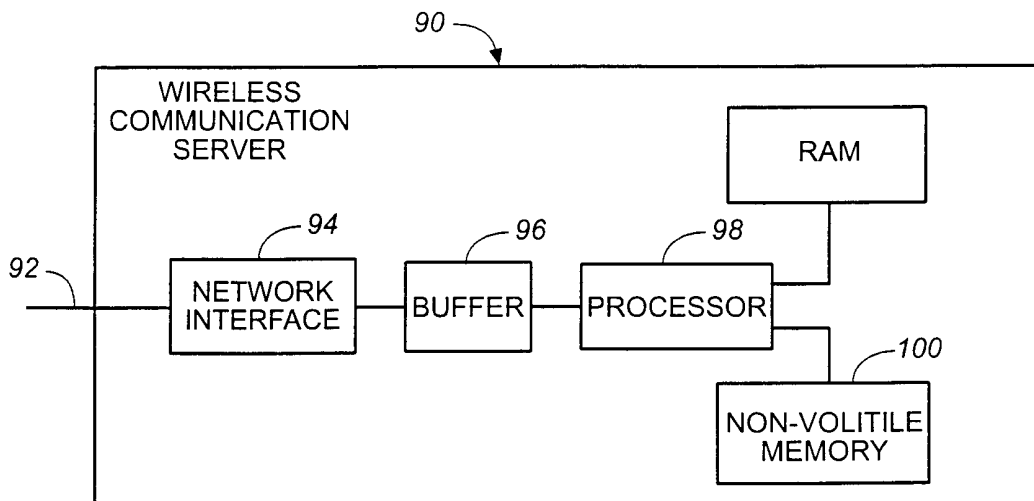
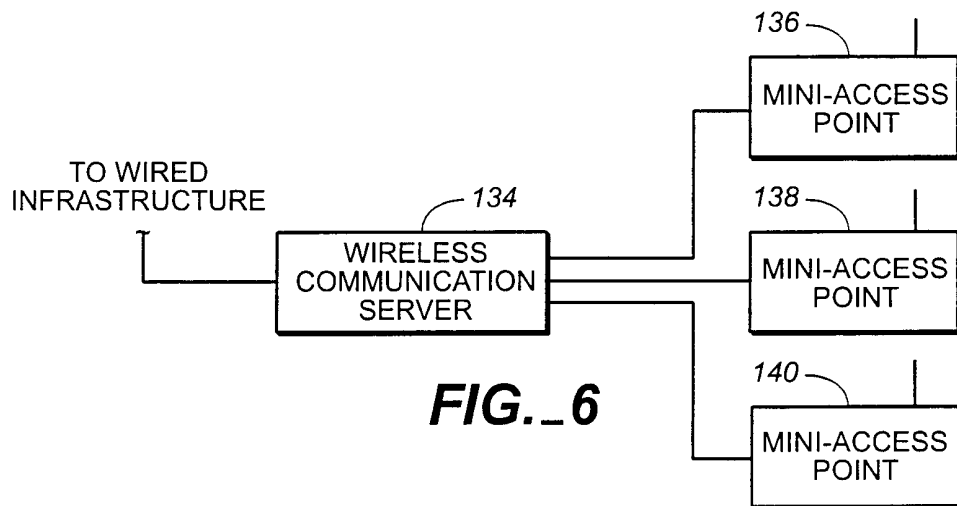
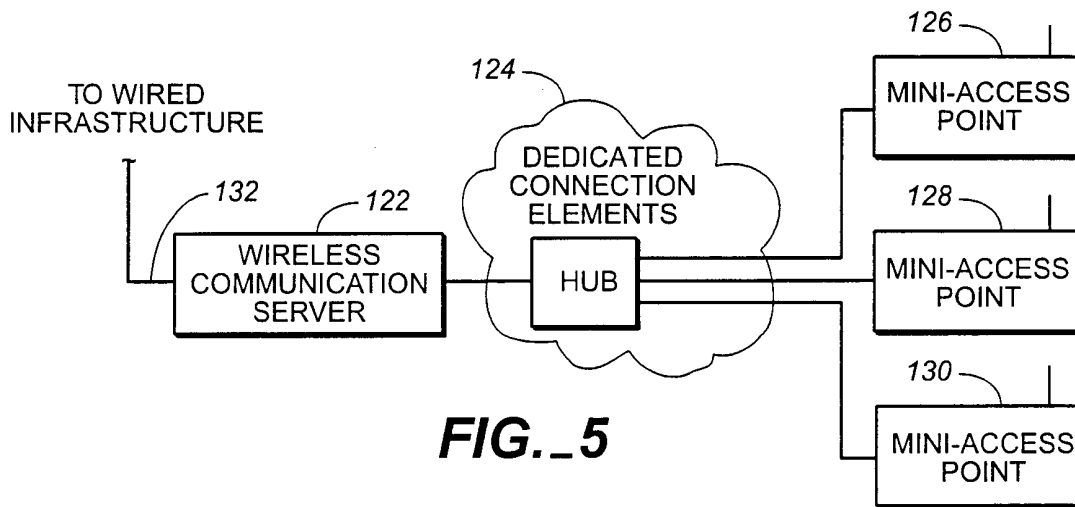

FIG.-3



**FIG. 4**

4 / 5



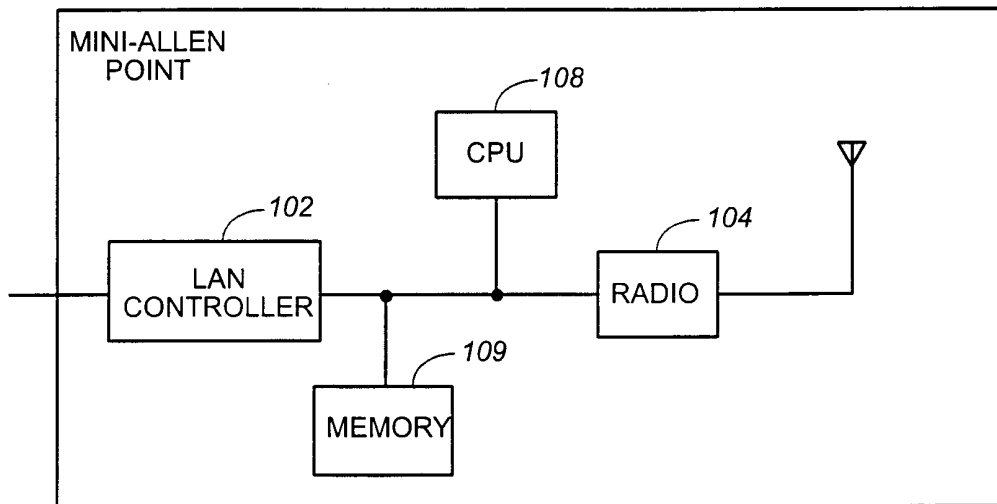

FIG. 8

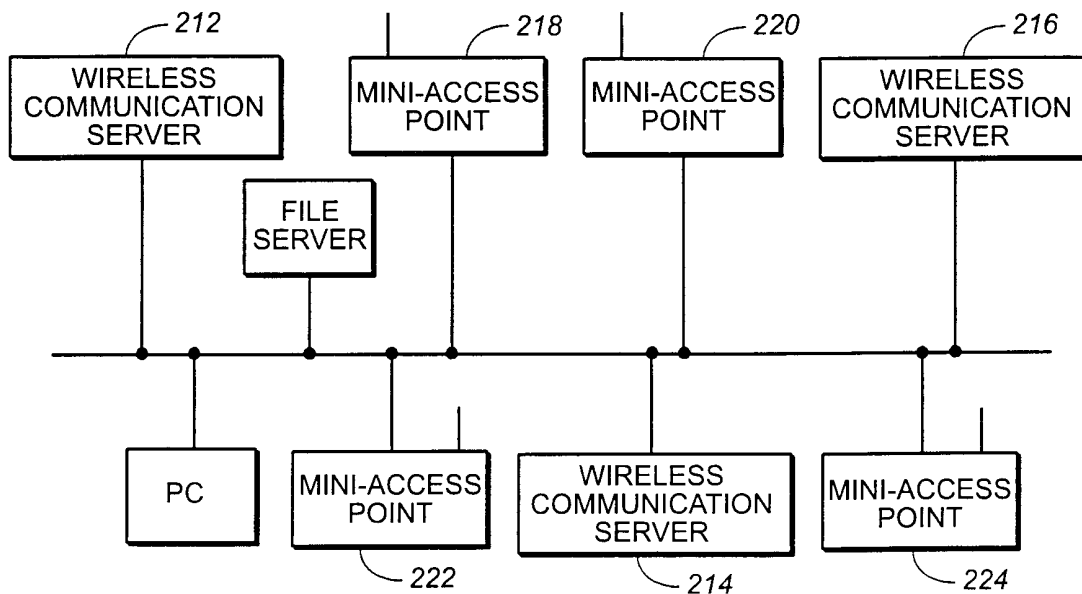

FIG. 9

# INTERNATIONAL SEARCH REPORT

International application No.

PCT/US00/33170

**A. CLASSIFICATION OF SUBJECT MATTER**

IPC(7) : H04Q 7/24  
 US CL : 370/338, 328

According to International Patent Classification (IPC) or to both national classification and IPC

**B. FIELDS SEARCHED**

Minimum documentation searched (classification system followed by classification symbols)  
 U.S. : 370/338, 328, 343, 345, 349, 389, 391, 392, 400

Documentation searched other than minimum documentation to the extent that such documents are included in the fields searched

Electronic data base consulted during the international search (name of data base and, where practicable, search terms used)  
 EAST, IEEE

**C. DOCUMENTS CONSIDERED TO BE RELEVANT**

Category *	Citation of document, with indication, where appropriate, of the relevant passages	Relevant to claim No.
Y	US 5,991,287 A (DIEPSTRATEN et al) 23 November 1999 (23.11.1999), Figure 1, column 3, lines 57-67, column 4, lines 1-67, column 5, lines 1-67, column 6, lines 1-35.	1-4, 6-9, 17, 25, 27, 29, 35-38, 42-49
Y	US 5,958,006 A (EGGLESTON et al) 28 September 1999 (28.9.1999), column 2, lines 50-67, column 3, lines 1-15, column 4, lines 51-67, column 5, lines 1-15, column 8, lines 56-67, column 10, lines 10-9.	1-4, 6-9, 17, 25, 27, 29, 35-38, 42-49
A, P	US 6,006,090 A (COLEMAN et al) 21 December 1999 (21.12.1999), entire document	1-53
A, P	US 6,101,531 A (EGGLESTON et al) 08 August 2000 (08.8.2000), entire document	1-53
A, P	US 6,067,291 A (KAMERMAN et al) 23 May 2000 (23.5.2000), entire document	1-53
A	US 5,339,316 A (DIEPSTRATEN) 16 August 1994 (16.8.1994), entire document	1-53

Further documents are listed in the continuation of Box C.

See patent family annex.

\* Special categories of cited documents:

"A" document defining the general state of the art which is not considered to be of particular relevance	"T" later document published after the international filing date or priority date and not in conflict with the application but cited to understand the principle or theory underlying the invention
"E" earlier application or patent published on or after the international filing date	"X" document of particular relevance; the claimed invention cannot be considered novel or cannot be considered to involve an inventive step when the document is taken alone
"L" document which may throw doubts on priority claim(s) or which is cited to establish the publication date of another citation or other special reason (as specified)	"Y" document of particular relevance; the claimed invention cannot be considered to involve an inventive step when the document is combined with one or more other such documents, such combination being obvious to a person skilled in the art
"O" document referring to an oral disclosure, use, exhibition or other means	"&" document member of the same patent family
"P" document published prior to the international filing date but later than the priority date claimed	

Date of the actual completion of the international search

09 February 2001 (09.02.2001)

Date of mailing of the international search report

**30 MAR 2001**

Name and mailing address of the ISA/US

Commissioner of Patents and Trademarks  
 Box PCT  
 Washington, D.C. 20231  
 Facsimile No. (703)305-3230

Authorized officer

Kizou Hassan

Telephone No. (703) 305-4700

