

- (21) Application No 7925177
- (22) Date of filing 19 Jul 1979
- (23) Claims filed 19 Jul 1979
- (30) Priority data
- (31) 24757/78
- (32) 31 May 1978
- (33) United Kingdom (GB)
- (43) Application published 16 Jan 1980
- (51) INT CL³
E06B 5/10
- (52) Domestic classification
E1J GM GN
- (56) Documents cited
GB 1514134
GB 1432687
GB 1342190
GB 1110601
GB 1101503
- (58) Field of search
E1J
- (71) Applicants
William Miller Hutchison,
Woodside Cottage,
Auchenblae,
Kincardineshire, Scotland,
Andrew Lewis Broadley, 2
High Street, Edzell,
Angus, Scotland
- (72) Inventors
William Miller Hutchison,
Andrew Lewis Broadley
- (74) Agents
Cruikshank & Fairweather

(54) A structure for and a method of substantially preventing the passage of a liquid e.g. flood water through an opening e.g. a doorway

(57) A structure for the prevention of liquid ingress through openings especially windows and doors comprises an elongate channel 6 formed in a wall (3) and a sill 1 with a

first, fluid-inflatable bead 11 on one elongate side and a second resilient bead 12 on the opposed side and a barrier member 13 disposable so that part of the edge of the barrier enters the channel 6 between the first and second beads.

A method of protecting an opening against liquid ingress comprising forming the above structure is described.

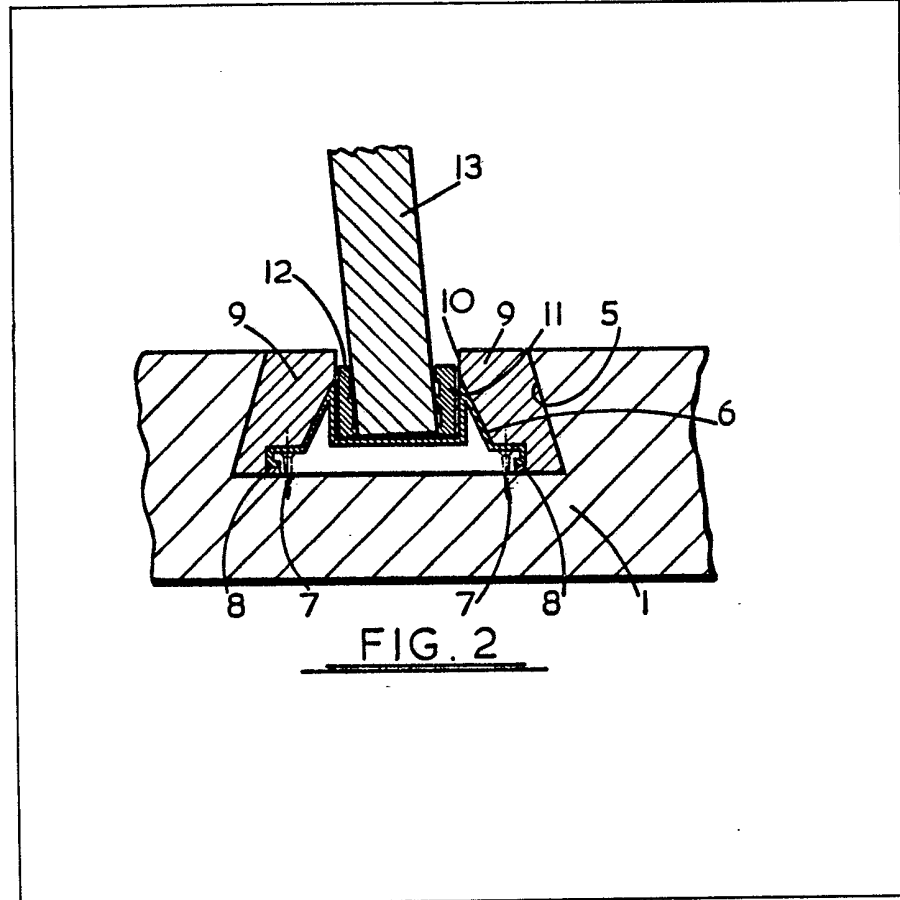

SPECIFICATION

A method of substantially preventing the passage of a liquid through an opening and a structure for use in said method

5 The invention relates to a method of substantially preventing the passage of a liquid through an opening, the term "opening" being used herein to denote not only a permanent opening, but also an opening provided with a closure member (for example a door) and an opening which is normally closed but which can be opened by the fracture of a fragile member (for example a window pane) by the pressure of the liquid or by solids carried by the liquid. The invention also relates to a structure for use in said method.

10 The invention provides a method of substantially preventing the passage of liquid through an opening (as hereinbefore defined) which method comprises:
 20 forming in members defining at least the lowest portion of said opening an elongate channel;
 providing a first, fluid-inflatable bead within said channel on one elongate side thereof;
 25 providing a second bead within said channel on the opposed side thereof; and
 providing a barrier member substantially impervious to said liquid, and disposable within said opening with part of the edge of the barrier member in the channel and disposed between the first and second beads;
 the arrangement being such that when fluid is passed into the first bead, the first bead is inflated causing the first and second beads to engage the said part of the edge of the barrier and form along the said part of the edge a substantially liquid-tight seal.

30 The invention also provides a structure comprising:
 40 at least one member having a wall defining an opening, at least part of said wall being provided with an elongate channel;
 a first, fluid-inflatable bead disposed with said channel on one elongate side thereof;
 45 a second bead disposed within said channel on the opposed side thereof; and
 a barrier member disposable within said opening so that part of the edge of the barrier enters the channel and is disposed between the first and second beads said barrier member being substantially impervious to said liquid;
 the first bead being such that, when the said part of the edge of the barrier is disposed between the first and second beads inflation of the first bead will cause the first and second beads to engage the said part of the edge of the barrier and form along the said part of the edge a substantially liquid-tight seal.

50 A preferred embodiment of the invention will now be described, though by way of illustration only, with reference to the accompanying drawings, in which:

Figure 1 is an isometric view of a structure of the invention having the form of a doorway; and

65 Figure 2 is a section through the base of the doorway shown in Figure 1.

70 The doorway shown in the accompanying drawings comprises a slipstep 1, a lintel 2 and two vertical walls 3 which together define a rectangular opening which can be closed by means of a door 4. Across the entire width of the slipstep 1 and up approximately two-thirds of the height of the edge of each wall 3 defining the opening is cut an elongate recess 5 of trapezoidal cross-section (as best seen in Figure 2), the recess sloping outwardly from the closed door 4 as it extends up the walls 3. Within the recess is disposed an extruded channel section 6 which is secured to the base of the recess by means of screws 7 and which is bedded on butyl mastic 8. A dense mortar infill 9 is disposed on either side of the channel section 6 and helps to retain the channel section 6 in position. As shown in Figure 2, the channel section 6 and the infill 9 together define an elongate channel 10 of rectangular cross-section. On the elongate side of the channel 10 nearer the door 4 is fixedly secured a pneumatically-inflatable first bead 11, whilst on the opposed elongate side of the channel 10 is fixedly secured a second bead 12 formed of a cellular synthetic resin.

80 A rectangular glass-fibre barrier 13 can be disposed within the doorway so that its lower edge and its side edges enter the channel 10. Subsequent inflation of the first bead 11 with a pump or a compressed gas cartridge causes the first and second beads to engage the lower and side edges of the barrier 13 and form therewith a water-tight seal. Thus by disposing the barrier 13 within the doorway between the first and second beads and inflating the first bead, the barrier 13 can be made to act as a flood barrier preventing the passage of flood water which may be present outside the doorway through the doorway.

95 The pneumatically-inflatable bead used in the preferred embodiment of the invention just described may be replaced by a hydraulically-inflatable one.

100 The method of the present invention may be used to prevent the passage of flood water not only through doorways but also through windows, ventilators and other openings in buildings, and may also be used to provide sluice gates in watercourses. In the latter case, preferably a plurality of structures of the invention are disposed side-by-side to form a dam across the watercourse, flow through the dam being regulated by removing one or more of the barriers of the structures. It is believed that other applications of the method and structure of the invention will be apparent to those skilled in the art.

115 In a further aspect the present invention provides a method of protecting an opening as hereinbefore defined against the passage of liquid through the opening which method comprises:
 120 forming in members defining at least the lowest portion of said opening an elongate channel;
 providing a first, fluid-inflatable bead within

said channel on one elongate side thereof;
 providing a second bead within said channel on
 the opposed side thereof; and

5 providing a barrier member substantially
 impervious to said liquid, and disposable within
 said opening with part of the edge of the barrier
 member in the channel and disposed between the
 first and second beads;

10 the arrangement being such that when fluid is
 passed into the first bead, the first bead is inflated
 causing the first and second beads to engage the
 said part of the edge of the barrier and form along
 the said part of the edge a substantially liquid-
 tight seal.

15 It will of course be appreciated that in some
 cases, especially with regard to door openings, the
 wall defining the opening does not exist as such
 below the base of the opening, said base being
 defined by a floor extending from one side of the
 20 wall and opening to the other side thereof which
 could conceivably be considered not to form part
 of the wall. Such openings are nevertheless to be
 considered as being defined by the wall and
 included within the scope of the present invention,
 25 that part of the floor extending directly between
 the wall at either side of the opening being
 considered as part of said wall defining the
 opening.

CLAIMS

30 1. A structure having an opening with a liquid-
 resistant barrier which structure comprises
 at least one member having a wall defining an
 opening, at least part of said wall being provided
 with an elongate channel;

35 a first, fluid-inflatable bead disposed with said
 channel on one elongate side thereof;
 a second bead disposed within said channel on
 the opposed side thereof; and

40 a barrier member disposable within said
 opening so that part of the edge of the barrier
 enters the channel and is disposed between the
 first and second beads said barrier member being
 substantially impervious to said liquid;

45 the first bead being such that, when the said part
 of the edge of the barrier is disposed between the
 first and second beads inflation of the first bead
 will cause the first and second beads to engage
 the said part of the edge of the barrier and form
 along the said part of the edge a substantially
 50 liquid-tight seal.

2. A method as claimed in Claim 1, wherein
 said channel is trapezoidal in cross-section being
 broader towards its base.

55 3. A structure as claimed in Claim 1 or Claim 2,
 wherein said opening in the wall extends in a
 substantially vertical plane and said channel
 extends along the base of said opening and along
 at least the lower sides of the opening.

60 4. A structure as claimed in Claim 3, wherein
 the portions of the elongate channel in the sides
 are inclined outwardly with respect to the main
 plane of the opening towards the top of the
 opening.

5. A structure as claimed in any one of Claims 1

65 to 4, wherein the liquid impervious barrier
 member comprises a rigid or semi-rigid sheet of a
 water-impervious material.

6. A structure as claimed in Claim 5, wherein
 the barrier member is of glass-fibre.

70 7. A structure as claimed in any one of Claims 1
 to 6, wherein the first bead is pneumatically
 inflatable.

8. A structure as claimed in Claim 7 which
 includes pneumatic inflation means arranged to be
 75 automatically operable in response to a rising
 liquid level in proximity to the opening, so as to
 inflate said first bead.

9. A structure as claimed in Claim 7 or Claim 8,
 which includes pneumatic inflation means
 80 arranged to be automatically operable in response
 to insertion of the barrier member into said
 channel, so as to inflate said first bead.

10. A structure as claimed in any one of the
 preceding claims wherein the opening is a door or
 85 window opening.

11. A structure as claimed in any one of the
 Claims 1 to 9 which is a sluice gate.

12. A structure as claimed in Claim 11, wherein
 is provided a plurality of said openings each
 90 having an independently operable barrier member
 and first bead.

13. A structure having an opening with a liquid
 resistant barrier according to Claim 1, substantially
 as described hereinbefore with particular
 95 reference to the accompanying drawings.

14. A method of protecting an opening as
 hereinbefore defined against the passage of liquid
 through the opening, which method comprises:

100 forming in members defining at least the lowest
 portion of said opening an elongate channel;
 providing a first, fluid-inflatable bead within
 said channel on one elongate side thereof;
 providing a second bead within said channel on
 the opposed side thereof; and

105 providing a barrier member substantially
 impervious to said liquid, and disposable within
 said opening with part of the edge of the barrier
 member in the channel and disposed between the
 first and second beads;

110 the arrangement being such that when fluid is
 passed into the first bead, the first bead is inflated
 causing the first and second beads to engage the
 said part of the edge of the barrier and form along
 the said part of the edge a substantially liquid-
 115 tight seal.

15. A method as claimed in Claim 14, in which
 the elongate channel is formed so as to extend up
 at least the lower part of each side of the opening.

120 16. A method as claimed in Claim 15, in which
 the opening in the wall extends in a substantially
 vertical plane and said channel is formed in the
 sides of the opening so as to incline outwardly
 with respect to the main plane of the opening
 towards the top of the opening.

125 17. A method as claimed in any one of Claims
 14 to 16, in which the elongate channel is formed
 with a trapezoidal cross-section being broader
 towards its base.

18. A method as claimed in any one of Claims

14 to 17, wherein the opening is a door or window opening.

5 19. A method as claimed in any one of Claims 14 to 18, which includes the steps of disposing the barrier member with said part of the edge thereof in the channel and between the first and

second beads and passing fluid into the first bead.

10 20. A method of protecting an opening against the passage of liquid according to Claim 14, substantially as described hereinbefore with particular reference to the accompanying drawings.