



- (51) International Patent Classification:  
C07F 13/00 (2006.01)
- (21) International Application Number:  
PCT/US2012/056173
- (22) International Filing Date:  
20 September 2012 (20.09.2012)
- (25) Filing Language: English
- (26) Publication Language: English
- (30) Priority Data:  
61/536,799 20 September 2011 (20.09.2011) US
- (71) Applicant: **DOW CORNING CORPORATION**  
[US/US]; 2200 West Salzburg Road, Midland, MI 48686-0994 (US).
- (72) Inventors: **BRANDSTADT, Kurt**; 5818 Wimbledon Court, Midland, MI 48642 (US). **COOK, Simon**; 1601 Settlers Passage, Midland, MI 48642 (US). **NGUYEN, Binh, Thanh**; 108 Hunters Ridge, Midland, MI 48640 (US). **SURGENOR, Avril**; Avenue Du Champ De Mai 29, Waterloo, Belgium 1410 (GB). **TAYLOR, Richard**; 140 South Road, Sully, Penarth CF64 5SP (GB). **TZOU, Ming-Shin**; 2611 Walden Woods Court, Midland, MI 48640 (US).
- (74) Agent: **BROWN, Catherine, U.**; Dow Corning Corporation, Patent Department - Mail Co1232, 2200 West Salzburg Road, Midland, MI 48686-0994 (US).

(81) Designated States (unless otherwise indicated, for every kind of national protection available): AE, AG, AL, AM, AO, AT, AU, AZ, BA, BB, BG, BH, BN, BR, BW, BY, BZ, CA, CH, CL, CN, CO, CR, CU, CZ, DE, DK, DM, DO, DZ, EC, EE, EG, ES, FI, GB, GD, GE, GH, GM, GT, HN, HR, HU, ID, IL, IN, IS, JP, KE, KG, KM, KN, KP, KR, KZ, LA, LC, LK, LR, LS, LT, LU, LY, MA, MD, ME, MG, MK, MN, MW, MX, MY, MZ, NA, NG, NI, NO, NZ, OM, PA, PE, PG, PH, PL, PT, QA, RO, RS, RU, RW, SC, SD, SE, SG, SK, SL, SM, ST, SV, SY, TH, TJ, TM, TN, TR, TT, TZ, UA, UG, US, UZ, VC, VN, ZA, ZM, ZW.

(84) Designated States (unless otherwise indicated, for every kind of regional protection available): ARIPO (BW, GH, GM, KE, LR, LS, MW, MZ, NA, RW, SD, SL, SZ, TZ, UG, ZM, ZW), Eurasian (AM, AZ, BY, KG, KZ, RU, TJ, TM), European (AL, AT, BE, BG, CH, CY, CZ, DE, DK, EE, ES, FI, FR, GB, GR, HR, HU, IE, IS, IT, LT, LU, LV, MC, MK, MT, NL, NO, PL, PT, RO, RS, SE, SI, SK, SM, TR), OAPI (BF, BJ, CF, CG, CI, CM, GA, GN, GQ, GW, ML, MR, NE, SN, TD, TG).

**Published:**

— without international search report and to be republished upon receipt of that report (Rule 48.2(g))



WO 2013/043767 A2

(54) Title: RHENIUM CONTAINING HYDROSILYLATION CATALYSTS AND COMPOSITIONS CONTAINING THE CATALYSTS

(57) Abstract: A composition contains (A) a hydrosilylation reaction catalyst and (B) an aliphatically unsaturated compound having an average, per molecule, of one or more aliphatically unsaturated organic groups capable of undergoing hydrosilylation reaction. The composition is capable of reacting via hydrosilylation reaction to form a reaction product, such as a silane, a gum, a gel, a rubber, or a resin. Ingredient (A) contains a metal-ligand complex that can be prepared by a method including reacting a metal precursor and a ligand.

## RHENIUM CONTAINING HYDROSILYLATION CATALYSTS AND COMPOSITIONS CONTAINING THE CATALYSTS

**[0001]** Catalysts for catalyzing hydrosilylation reaction are known in the art and are commercially available. Such conventional hydrosilylation catalysts can be a metal selected from platinum, rhodium, ruthenium, palladium, osmium, and iridium. Alternatively, the hydrosilylation catalyst may be a compound of such a metal, for example, chloroplatinic acid, chloroplatinic acid hexahydrate, platinum dichloride, and complexes of said compounds with low molecular weight organopolysiloxanes or platinum compounds microencapsulated in a matrix or core/shell type structure. Complexes of platinum with low molecular weight organopolysiloxanes include 1,3-diethenyl-1,1,3,3-tetramethyldisiloxane complexes with platinum. These complexes may be microencapsulated in a resin matrix. Exemplary hydrosilylation catalysts are described in U.S. Patents 3,159,601; 3,220,972; 3,296,291; 3,419,593; 3,516,946; 3,814,730; 3,989,668; 4,784,879; 5,036,117; and 5,175,325 and EP 0 347 895 B. Microencapsulated hydrosilylation catalysts and methods of preparing them are known in the art, as exemplified in U.S. Patents 4,766,176 and 5,017,654.

**[0002]** These hydrosilylation catalysts suffer from the drawback of being extremely costly. Some of the metals in these hydrosilylation catalysts may also be difficult to obtain, and some of these hydrosilylation catalysts may be difficult to prepare. There is a need in industry to replace the conventional hydrosilylation catalysts described above with a less expensive and/or more readily available alternative.

### BRIEF SUMMARY OF THE INVENTION

**[0003]** A reaction product of ingredients comprising a Rhenium precursor (Re precursor) and a ligand, and methods for preparation of the reaction product are disclosed. A composition, which is capable of forming a reaction product via hydrosilylation reaction, comprises the reaction product and an aliphatically unsaturated compound having an average, per molecule, of one or more aliphatically unsaturated organic groups capable of undergoing hydrosilylation reaction. When the aliphatically unsaturated compound lacks a silicon bonded hydrogen atom, then the composition further comprises an SiH functional compound having an average, per molecule, of one or more silicon bonded hydrogen atoms.

### DETAILED DESCRIPTION OF THE INVENTION

**[0004]** All amounts, ratios, and percentages are by weight unless otherwise indicated. The articles 'a', 'an', and 'the' each refer to one or more, unless otherwise indicated by the context of specification. The disclosure of ranges includes the range itself and also anything subsumed therein, as well as endpoints. For example, disclosure of a range of 2.0 to 4.0 includes not only the range of 2.0 to 4.0, but also 2.1, 2.3, 3.4, 3.5, and 4.0 individually, as well as any other number subsumed in the range. Furthermore, disclosure of a range of, for example, 2.0 to 4.0

includes the subsets of, for example, 2.1 to 3.5, 2.3 to 3.4, 2.6 to 3.7, and 3.8 to 4.0, as well as any other subset subsumed in the range. Similarly, the disclosure of Markush groups includes the entire group and also any individual members and subgroups subsumed therein. For example, disclosure of the Markush group a hydrogen atom, an alkyl group, an aryl group, or an aralkyl group includes the member alkyl individually; the subgroup alkyl and aryl; and any other individual member and subgroup subsumed therein.

**[0005]** "Alkyl" means an acyclic, branched or unbranched, saturated monovalent hydrocarbon group. Alkyl is exemplified by, but not limited to, methyl, ethyl, propyl (*e.g.*, iso-propyl and/or n-propyl), butyl (*e.g.*, isobutyl, n-butyl, tert-butyl, and/or sec-butyl), pentyl (*e.g.*, isopentyl, neopentyl, and/or tert-pentyl), hexyl, heptyl, octyl, nonyl, and decyl, as well as branched saturated monovalent hydrocarbon groups of 6 or more carbon atoms.

**[0006]** "Aryl" means a cyclic, fully unsaturated, hydrocarbon group. Aryl is exemplified by, but not limited to, cyclopentadienyl, phenyl, anthracenyl, and naphthyl. Monocyclic aryl groups may have 5 to 9 carbon atoms, alternatively 6 to 7 carbon atoms, and alternatively 5 to 6 carbon atoms. Polycyclic aryl groups may have 10 to 17 carbon atoms, alternatively 10 to 14 carbon atoms, and alternatively 12 to 14 carbon atoms.

**[0007]** "Aralkyl" means an alkyl group having a pendant and/or terminal aryl group or an aryl group having a pendant alkyl group. Exemplary aralkyl groups include tolyl, xylyl, benzyl, phenylethyl, phenyl propyl, and phenyl butyl.

**[0008]** "Carbocycle" and "carbocyclic" each mean a hydrocarbon ring. Carbocycles may be monocyclic or alternatively may be fused, bridged, or spiro polycyclic rings. Monocyclic carbocycles may have 3 to 9 carbon atoms, alternatively 4 to 7 carbon atoms, and alternatively 5 to 6 carbon atoms. Polycyclic carbocycles may have 7 to 17 carbon atoms, alternatively 7 to 14 carbon atoms, and alternatively 9 to 10 carbon atoms. Carbocycles may be saturated or partially unsaturated.

**[0009]** "Cycloalkyl" means saturated carbocycle. Monocyclic cycloalkyl groups are exemplified by cyclobutyl, cyclopentyl, and cyclohexyl.

**[0010]** "Halogenated hydrocarbon" means a hydrocarbon where one or more hydrogen atoms bonded to a carbon atom have been formally replaced with a halogen atom. Halogenated hydrocarbon groups include haloalkyl groups, halogenated carbocyclic groups, and haloalkenyl groups. Haloalkyl groups include fluorinated alkyl groups such as trifluoromethyl (CF<sub>3</sub>), fluoromethyl, trifluoroethyl, 2-fluoropropyl, 3,3,3-trifluoropropyl, 4,4,4-trifluorobutyl, 4,4,4,3,3-pentafluorobutyl, 5,5,5,4,4,3,3-heptafluoropentyl, 6,6,6,5,5,4,4,3,3-nonafluorohexyl, and 8,8,8,7,7-pentafluorooctyl; and chlorinated alkyl groups such as chloromethyl and 3-chloropropyl. Halogenated carbocyclic groups include fluorinated cycloalkyl groups such as 2,2-difluorocyclopropyl, 2,3-difluorocyclobutyl, 3,4-difluorocyclohexyl, and 3,4-difluoro-5-

methylcycloheptyl; and chlorinated cycloalkyl groups such as 2,2-dichlorocyclopropyl, 2,3-dichlorocyclopentyl. Haloalkenyl groups include allyl chloride.

**[0011]** “Heteroatom” means any of the Group 13-17 elements of the IUPAC Periodic Table of the Elements at [http://www.iupac.org/fileadmin/user\\_upload/news/IUPAC\\_Periodic\\_Table-1Jun12.pdf](http://www.iupac.org/fileadmin/user_upload/news/IUPAC_Periodic_Table-1Jun12.pdf), except carbon. “Heteroatom” include, for example, N, O, P, S, Br, Cl, F, and I.

**[0012]** “Heteroatom containing group” means an organic group comprised of a carbon atom and that also includes at least one heteroatom. Heteroatom containing groups may include, for example, one or more of acyl, amide, amine, carboxyl, cyano, epoxy, hydrocarboxy, imino, ketone, ketoxime, mercapto, oxime, and/or thiol. For example, when the heteroatom containing group contains one or more halogen atoms, then the heteroatom containing group may be a halogenated hydrocarbon group as defined above. Alternatively, when the heteroatom is oxygen, then the heteroatom containing group may be a hydrocarboxy group such as an alkoxy group or an alkylalkoxy group.

**[0013]** “Inorganic heteroatom containing group” means group comprised of at least 1 heteroatom and at least 1 of hydrogen or a different heteroatoms. Heteroatom containing groups may include, for example, one or more of amine, hydroxyl, imino, nitro, oxo, sulfonyl, and/or thiol.

**[0014]** “Heteroalkyl” group means an acyclic, branched or unbranched, saturated monovalent hydrocarbon group that also includes at least one heteroatom. “Heteroalkyl” includes haloalkyl groups and alkyl groups in which at least one carbon atom has been replaced with a heteroatom such as N, O, P, or S, *e.g.*, when the heteroatom is O, the heteroalkyl group may be an alkoxy group.

**[0015]** “Heterocycle” and “heterocyclic” each mean a ring group comprised of carbon atoms and one or more heteroatoms in the ring. The heteroatom in the heterocycle may be N, O, P, S, or a combination thereof. Heterocycles may be monocyclic or alternatively may be fused, bridged, or spiro polycyclic rings. Monocyclic heterocycles may have 3 to 9 member atoms in the ring, alternatively 4 to 7 member atoms, and alternatively 5 to 6 member atoms. Polycyclic heterocycles may have 7 to 17 member atoms, alternatively 7 to 14 member atoms, and alternatively 9 to 10 member atoms. Heterocycles may be saturated or partially unsaturated.

**[0016]** “Heteroaromatic” means a fully unsaturated ring containing group comprised of carbon atoms and one or more heteroatoms in the ring. Monocyclic heteroaromatic groups may have 5 to 9 member atoms, alternatively 6 to 7 member atoms, and alternatively 5 to 6 member atoms. Polycyclic heteroaromatic groups may have 10 to 17 member atoms, alternatively 10 to 14 member atoms, and alternatively 12 to 14 member atoms.

Heteroaromatic includes heteroaryl groups such as pyridyl. Heteroaromatic includes heteroalkyl, *i.e.*, an alkyl group having a pendant and/or terminal heteroaryl group or a

heteroaryl group having a pendant alkyl group. Exemplary heteroaralkyl groups include methylpyridyl and dimethylpyridyl.

**[0017]** Abbreviations used herein are defined as follows. The abbreviation "cP" means centiPoise, and "cSt" means centiStokes. "DP" means the degree of polymerization. "FTIR" means Fourier transform infrared spectroscopy. "GC" means gas chromatography. "GPC" means gel permeation chromatography. "Mn" means number average molecular weight. Mn may be measured using GPC. "Mw" means weight average molecular weight. "NMR" means nuclear magnetic resonance. "Pa·s" means Pascal seconds, and "ppm" means parts per million. "COD" means cyclooctadienyl. "Et" means ethyl. "Me" means methyl. "Ph" means phenyl. "Pr" means propyl and includes various structures such as iPr and nPr. "iPr" means isopropyl. "nPr" means normal propyl. "Bu" means butyl and includes various structures including nBu, sec-butyl, tBu, and iBu. "iBu" means isobutyl. "nBu" means normal butyl. "tBu" means tert-butyl. "AcAc" means acetyl acetate. "2-EHA" means 2-ethylhexanoate. "OAc" means acetate. "Hex" means hexenyl. "THF" means tetrahydrofuran. "Vi" means vinyl.

**[0018]** "M-unit" means a siloxane unit having formula  $R_3SiO_{1/2}$ , where each R independently represents a monovalent atom or organic group. "D-unit" means a siloxane unit having formula  $R_2SiO_{2/2}$ , where each R independently represents a monovalent atom or group. "T-unit" means a siloxane unit having formula  $RSiO_{3/2}$ , where each R independently represents a monovalent atom or group. "Q-unit" means a siloxane unit having formula  $SiO_{4/2}$ .

**[0019]** "Non-functional" means that the ingredient does not have either an aliphatically unsaturated substituent or a silicon bonded hydrogen atom that participates in a hydrosilylation reaction.

**[0020]** "Free of" means that the composition contains a non-detectable amount of the ingredient, or the composition contains an amount of the ingredient insufficient to change the GC measurement measured as described in the Examples section, as compared to the same composition with the ingredient omitted. For example, the composition described herein may be free of platinum catalysts. "Free of platinum catalysts" means that the composition contains a non-detectable amount of a platinum catalyst capable of catalyzing a hydrosilylation reaction with the unsaturated groups on other ingredients in the composition, or the composition contains an amount of a platinum catalyst insufficient to change the GC measurement measured as described in the Examples section, as compared to the same composition with the platinum catalyst omitted. The composition may be free of conventional metal catalysts. "Free of conventional metal catalysts" means that the composition contains a non-detectable amount of a the metal selected from Pt, Rh, Ru, Pd, Os, and Ir, or the compound of such a metal capable of catalyzing a hydrosilylation reaction with the unsaturated groups on other ingredients in the composition, or the composition contains an amount of the conventional

metal catalyst insufficient to change the GC measurement measured as described in the Examples section, as compared to the same composition with the conventional metal catalyst omitted. Alternatively, the composition described herein may be free of hydrosilylation reaction catalysts (*i.e.*, free of any ingredient capable of catalyzing a hydrosilylation reaction of the aliphatically unsaturated groups on ingredient (B), described below, other than ingredient (A) described herein).

**[0021]** The composition, which has at least one ingredient capable of reacting by hydrosilylation reaction (composition), comprises:

(A) a Re containing hydrosilylation reaction catalyst, and

(B) an aliphatically unsaturated compound having an average, per molecule, of one or more aliphatically unsaturated organic groups capable of undergoing hydrosilylation reaction.

Without wishing to be bound by theory, it is thought that the Re containing hydrosilylation reaction catalyst is characterizable as being effective for catalyzing the hydrosilylation reaction of the composition. The hydrosilylation reaction of the composition prepares a reaction product.

The reaction product may have a form selected from the group consisting of a silane, a gum, a gel, a rubber, and a resin.

**[0022]** When ingredient (B) does not contain a silicon bonded hydrogen atom, then the composition further comprises ingredient (C), an SiH functional compound having an average, per molecule, of one or more silicon bonded hydrogen atoms, which is distinct from ingredients

(A) and (B).

**[0023]** The composition may optionally further comprise one or more additional ingredients, which are distinct from ingredient (A), ingredient (B), and ingredient (C) described above.

Suitable additional ingredients are exemplified by (D) a spacer; (E) an extender, a plasticizer, or a combination thereof; (F) a filler; (G) a filler treating agent; (H) a biocide; (I) a stabilizer, (J) a flame retardant; (K) a surface modifier; (L) a chain lengthener; (M) an endblocker; (N) a flux agent; (O) an anti-aging additive; (P) a pigment; (Q) an acid acceptor (R) a rheological additive; (S) a vehicle; (T) a surfactant; (U) a corrosion inhibitor; and a combination thereof.

**[0024]** Ingredient (A) is an Re containing hydrosilylation reaction catalyst. The Re containing hydrosilylation reaction catalyst comprises, or is prepared with, the reaction product of the Re precursor and the ligand. Without wishing to be bound by theory, it is thought that this reaction product comprises a Re-ligand complex. The Re precursor is distinct from the Re-ligand complex. The Re precursor is distinct from the reaction product of the Re precursor and the ligand.

**[0025]** The Re precursor may be a metal compound having general formula (i):  $\text{Re-A}_x$ , where each A is independently a displaceable substituent; and

subscript  $x$  is an integer with a value ranging from 1 to the maximum valence number of the metal atom selected for Re. Subscript  $x$  may be 3 to 5. Without wishing to be bound by theory, it is thought that one or more instances of A can be displaced from Re by the ligand to form the Re-ligand complex. Without wishing to be bound by theory, it is thought that one or more instances of group A are displaced by a complexation reaction between the Re precursor and the ligand to form the Re-ligand complex. Each instance of A in general formula (i) may be the same or different. Examples for A include halogen atoms and monovalent organic groups. The monovalent organic group may be a monovalent hydrocarbon group or a monovalent heteroatom containing group. The monovalent heteroatom containing group is exemplified by amino groups, halogenated hydrocarbon groups, silazane groups, carboxylate groups, carboxylic ester groups, carbonyl groups, hydrocarbonoxy groups, sulfonate ester groups, sulfonylimide groups, acetate groups, and cyano groups.

**[0026]** Examples of halogen atoms for A in general formula (i) include Br, Cl, or I. Examples of monovalent halogenated hydrocarbon groups for A include haloalkyl groups, *e.g.*, fluorinated alkyl groups such as CF<sub>3</sub>, fluoromethyl, trifluoroethyl, 2-fluoropropyl, 3,3,3-trifluoropropyl, 4,4,4-trifluorobutyl, 4,4,4,3,3-pentafluorobutyl, 5,5,5,4,4,3,3-heptafluoropentyl, 6,6,6,5,5,4,4,3,3-nonafluorohexyl, and 8,8,8,7,7-pentafluorooctyl; and chlorinated alkyl groups such as chloromethyl and 3-chloropropyl; halogenated carbocyclic groups such as fluorinated cycloalkyl groups such as 2,2-difluorocyclopropyl, 2,3-difluorocyclobutyl, 3,4-difluorocyclohexyl, and 3,4-difluoro-5-methylcycloheptyl; and chlorinated cycloalkyl groups such as 2,2-dichlorocyclopropyl, 2,3-dichlorocyclopentyl; and haloalkenyl groups such as allyl chloride.

**[0027]** Examples of monovalent hydrocarbon groups for A in general formula (i) include, but are not limited to, alkyl, alkenyl, carbocyclic, aryl, and aralkyl. Alkyl groups are exemplified by Me, Et, Pr, Bu, pentyl, hexyl, heptyl, ethylhexyl, octyl, decyl, dodecyl, undecyl, and octadecyl. Alkenyl groups are exemplified by Vi, allyl, propenyl, and Hex. Carbocyclic groups are exemplified by saturated carbocyclic groups, *e.g.*, cycloalkyl such as cyclopentyl and cyclohexyl, or unsaturated carbocyclic groups, *e.g.*, cycloalkenyl such as cyclopentadienyl, cyclohexenyl, or cyclooctadienyl. Aryl groups are exemplified by Ph, tolyl, xylyl, mesityl, and naphthyl. Aralkyl groups are exemplified by benzyl and 2-phenylethyl.

**[0028]** Examples of amino groups for A in general formula (i) have formula -NA'<sub>2</sub>, where each A' is independently a hydrogen atom or a monovalent hydrocarbon group. Exemplary monovalent hydrocarbon groups for A' include, but are not limited to, alkyl such as Me, Et, Pr, Bu, pentyl, hexyl, heptyl, ethylhexyl, octyl, decyl, dodecyl, undecyl, and octadecyl; alkenyl such as vinyl, allyl, propenyl, and Hex; carbocyclic groups exemplified by saturated carbocyclic groups, *e.g.*, cycloalkyl such as cyclopentyl and cyclohexyl, or unsaturated carbocyclic groups such as cyclopentadienyl or cyclooctadienyl; aryl such as Ph, tolyl, xylyl, mesityl, and naphthyl;

and aralkyl such as benzyl or 2-phenylethyl. Alternatively, each A' may be a hydrogen atom or an alkyl group of 1 to 4 carbon atoms, such as Me or Et.

**[0029]** Alternatively, each A in general formula (i) may be a silazane group.

**[0030]** Alternatively, each A in general formula (i) may be a carboxylic ester group. Examples of suitable carboxylic ester groups for A include, but are not limited to OAc, ethylhexanoate (such as 2-EHA), neodecanoate, octanoate, and stearate.

**[0031]** Examples of monovalent hydrocarboxy groups for A in general formula (i) may have formula -O-A", where A" is a monovalent hydrocarbon group. Examples of monovalent hydrocarbon groups for A" include, but are not limited to, alkyl such as Me, Et, Pr, Bu, pentyl, hexyl, heptyl, ethylhexyl, octyl, decyl, dodecyl, undecyl, and octadecyl; alkenyl such as Vi, allyl, propenyl, and Hex; cycloalkyl such as cyclopentyl and cyclohexyl; aryl such as Ph, tolyl, xylyl, and naphthyl; aralkyl such as benzyl or 2-phenylethyl. Alternatively, each A" may be an alkyl group, such as Me, Et, nPr, iPr, nBu, iBu, or tBu. Alternatively, each A" may be an alkyl group, and alternatively each A" may be Et, Pr such as iPr or nPr, or Bu.

**[0032]** Alternatively, each A in general formula (i) may be an alkyl group, such as Me, Et, nPr, iPr, nBu, iBu, or tBu. Alternatively, each A may be independently selected from the group consisting of Et, benzyl, mesityl, Ph, NEt<sub>2</sub>, NMe<sub>2</sub>, cyclooctadiene, ethoxide, iPr, Bu, 2-EHA, ethoxy, propoxy, methoxy, and carbonyl.

**[0033]** Alternatively, the Re precursor may be a commercially available compound, such as those shown below in Table 1.

Table 1

Precursor	Commercial Source
Re(III) Chloride	Sigma-Aldrich
Re(V) Chloride	Strem

**[0034]** In Table 1, "Sigma-Aldrich" refers to Sigma-Aldrich, Inc. of St. Louis, Missouri, U.S.A., and "Strem" refers to Strem Chemicals Inc. of Newburyport, Massachusetts, U.S.A.

**[0035]** The ligand is an organic compound that coordinates with Re. The ligand may have one of general formulae (ii) – (xx), below. In general formulae (ii) – (v),  $\equiv$  represents a single bond or a double bond, and  $\text{---}$  represents a covalent bond between a carbon atom in a ring and a substituent. The monovalent organic groups may be monovalent hydrocarbon groups or monovalent heteroatom containing groups. Examples of monovalent hydrocarbon groups include, but are not limited to, alkyl such as Me, Et, Pr, Bu, pentyl, or hexyl; alkenyl such as vinyl, allyl, propenyl, and hexenyl; carbocyclic groups exemplified by saturated carbocyclic groups, e.g., cycloalkyl such as cyclopentyl and cyclohexyl, or unsaturated carbocyclic groups

such as cyclopentadienyl or cyclooctadienyl; aryl such as Ph and naphthyl; aralkyl such as benzyl, tolyl, xylyl, mesityl, or 2-phenylethyl.

**[0036]** Examples of monovalent heteroatom containing groups in the general formulae include a halogenated hydrocarbon group or a hydrocarbonoxy group. Examples of monovalent

- 5 halogenated hydrocarbon groups include haloalkyl groups such as fluorinated alkyl groups, *e.g.*, CF<sub>3</sub>, fluoromethyl, trifluoroethyl, 2-fluoropropyl, 3,3,3-trifluoropropyl, and 4,4,4-trifluorobutyl; and chlorinated alkyl groups such as chloromethyl. Examples of hydrocarbonoxy groups for include alkoxy and aralkyloxy. Alkoxy groups are exemplified by OMe, OEt, OPr, and OBu; alternatively OMe. Aralkyloxy groups are exemplified by phenylmethoxy and
- 10 phenylethoxy. Alternatively, the monovalent heteroatom containing group may be an aryl group or an aralkyl group having one or more substituents bonded to a carbon atom in the ring, where one or more of the substituents contains a heteroatom, *e.g.*, aralkyloxy described above, or halogenated hydrocarbon groups such as

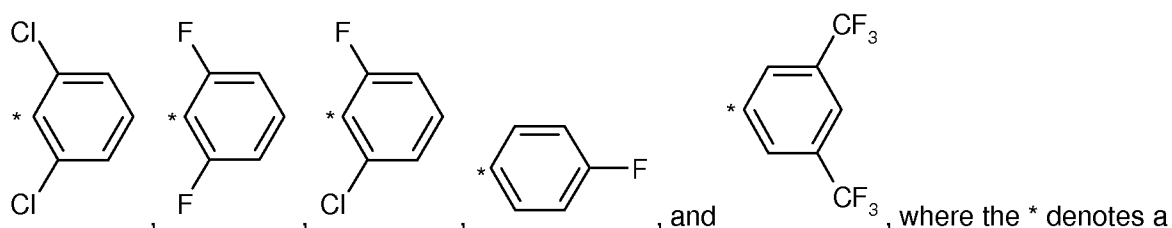

- 15 point of attachment.

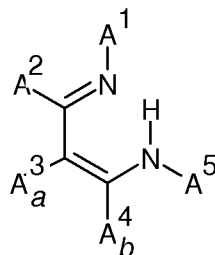

**[0037]** The ligand may have general formula (ii):

- [0038]** In general formula (ii), A<sup>1</sup>, A<sup>2</sup>, each A<sup>3</sup>, each A<sup>4</sup>, and A<sup>5</sup> are each independently selected from H and a monovalent organic group. Subscript *a* is 1 or 2 and subscript *b* is 1 or 2, depending on whether there is a single bond or a double bond between the two carbon
- 20 atoms bonded to A<sup>3</sup> and A<sup>4</sup>. Alternatively, A<sup>1</sup> and A<sup>5</sup> may each be independently selected from an aryl group such as Ph, an aralkyl group such as tolyl, xylyl, or mesityl, a heteroaromatic group, aralkyloxy such as phenylmethoxy or methoxyphenyl, and a halogenated hydrocarbon group such as

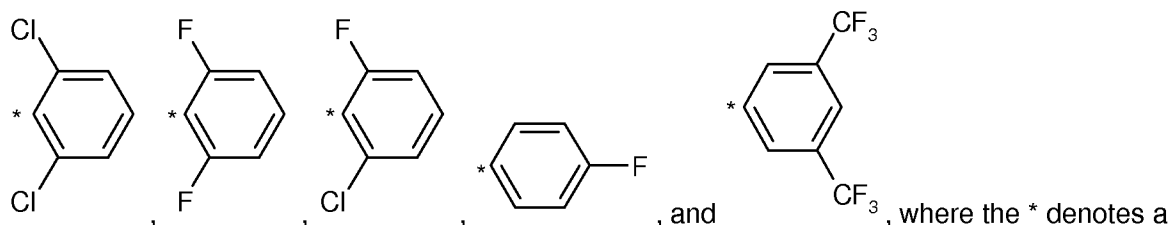

where the \* denotes a point of attachment. Alternatively,  $A^2$  and  $A^4$  may each independently be a monovalent hydrocarbon group, such as an alkyl group. The alkyl group for  $A^2$  and/or  $A^4$  may be selected from Me, Et, Pr, and Bu; alternatively Me. Alternatively,  $A^3$  may be H. Examples of ligands of general formula (ii) include ligand 1769.

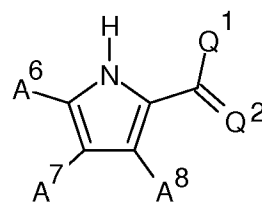

[0039] Alternatively, the ligand may have general formula (iii):

[0040] In general formula (iii),  $Q^1$  is selected from OH and SH.  $Q^2$  is selected from O and S. Alternatively,  $Q^1$  may be OH. Alternatively,  $Q^2$  may be O.  $A^6$ ,  $A^7$ , and  $A^8$  are each independently H and a monovalent organic group, with the provisos that  $A^6$  and/or  $A^7$  contain at least one carbon atom and  $A^6$  and  $A^7$  may be bonded together to form an aryl group fused with the 5 membered ring. Alternatively,  $A^6$  and  $A^7$  may be bonded together to form Ph, and  $A^8$  may be H. Examples of ligands of general formula (iii) include ligand 2806.

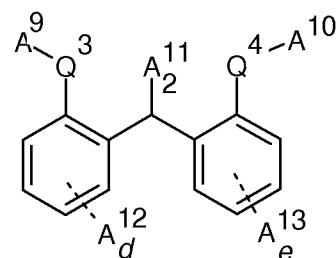

[0041] Alternatively, the ligand may have general formula (iv):

[0042] In general formula (iv), subscript  $d$  is an integer from 0 to 4, alternatively 0 to 3, alternatively 0 to 2, and alternatively 0 to 1. Subscript  $e$  is an integer from 0 to 4, alternatively 0 to 3, alternatively 0 to 2, and alternatively 0 to 1.

[0043] In general formula (iv),  $Q^3$  and  $Q^4$  are each independently selected from O and S. Alternatively,  $Q^3$  may be O. Alternatively,  $Q^4$  may be O.  $A^9$ ,  $A^{10}$ , and each  $A^{11}$  are each independently selected from H and a monovalent organic group. Each  $A^{12}$  and each  $A^{13}$  are independently selected from a halogen atom and a monovalent organic group. Alternatively  $A^9$  may be H. Alternatively  $A^{10}$  may be H. Alternatively, each  $A^{11}$  may be H or a monovalent

hydrocarbon group such an alkyl group selected from Me, Et, Pr, and Bu. The monovalent organic group for A<sup>12</sup> and/or A<sup>13</sup> may alternatively be an alkyl group, such as Me, Et, Pr, or Bu; or a halogen atom, such as Cl. Examples of ligands of general formula (iv) include ligand 4548.

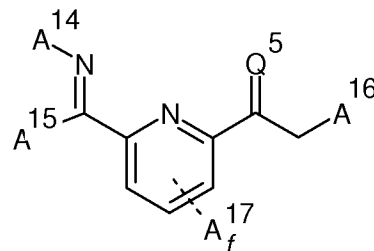

5 [0044] Alternatively, the ligand may have general formula (v):

[0045] In general formula (v), subscript *f* is an integer from 0 to 3, alternatively 0 to 2, and alternatively 0 to 1. Q<sup>5</sup> is selected from O and S, alternatively O. A<sup>14</sup>, A<sup>15</sup>, and each A<sup>16</sup> are each independently a monovalent organic group. Each A<sup>17</sup> is independently a halogen atom or a monovalent organic group. Alternatively, A<sup>14</sup> may be selected from an aryl group such as Ph, an aralkyl group such as tolyl, xylyl, or mesityl, a heteroaromatic group, aralkyloxy such as phenylmethoxy or methoxyphenyl, and a halogenated hydrocarbon group such as

10

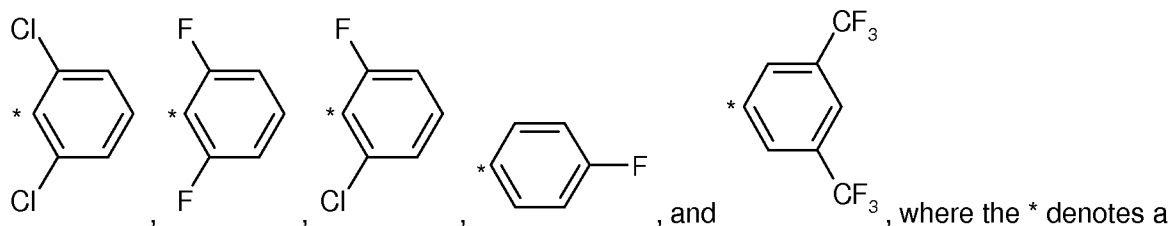

where the \* denotes a point of attachment. Alternatively, A<sup>15</sup> and/or A<sup>16</sup> may be a monovalent hydrocarbon group, such as an alkyl group. The alkyl group for A<sup>15</sup> and/or A<sup>16</sup> may be Me, Et, Pr, or Bu.

15

Alternatively, A<sup>17</sup> may be a halogen atom or a monovalent hydrocarbon group, such as an alkyl group. The halogen atom for A<sup>17</sup> may be Cl. The alkyl group for A<sup>17</sup> may be Me, Et, Pr, or Bu. Examples of ligands of general formula (v) include ligand 8945.

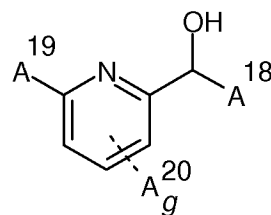

[0046] Alternatively, the ligand may have general formula (vi):

[0047] In general formula (vi), subscript *g* is an integer from 0 to 3, alternatively 0 to 2, and alternatively 0 to 1. A<sup>18</sup> and A<sup>19</sup> are each independently a monovalent organic group.

20

Alternatively, A<sup>18</sup> and/or A<sup>19</sup> may be selected from an aryl group such as Ph, an aralkyl group

such as tolyl, xylyl, or mesityl, a heteroaromatic group, aralkyloxy such as phenylmethoxy or methoxyphenyl, and a halogenated hydrocarbon group such as

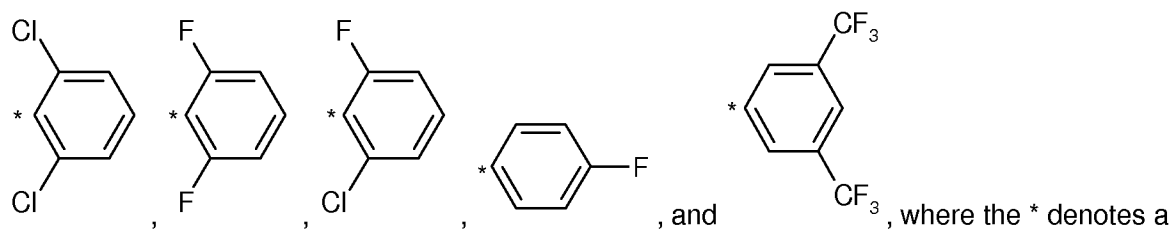

point of attachment. Each  $A^{20}$  is independently a halogen atom or a monovalent organic

- 5 group. Alternatively,  $A^{20}$  may be a halogen atom or a monovalent hydrocarbon group, such as an alkyl group. The halogen atom for  $A^{20}$  may be Cl. The alkyl group for  $A^{20}$  may be Me, Et, Pr, or Bu. Examples of ligands of general formula (vi) include ligand 7496.

**[0048]** The neutral forms exemplary ligands are shown in Tables 2 and 3. Alternatively, the ligand used to prepare ingredient (A) may be one of the ligands shown in Table 2.

- 10 Alternatively, the ligand used to prepare ingredient (A) may be one of the ligands shown in Table 3.

Table 2 – Ligands used with Re (V) Precursor, Rhenium (V) Chloride

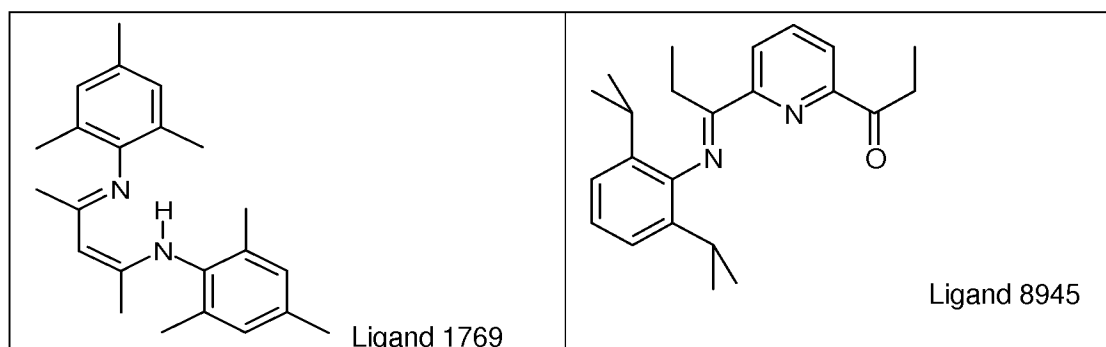

- 15 Table 3 – Ligands used with Re (III) Precursor, Rhenium (III) Chloride

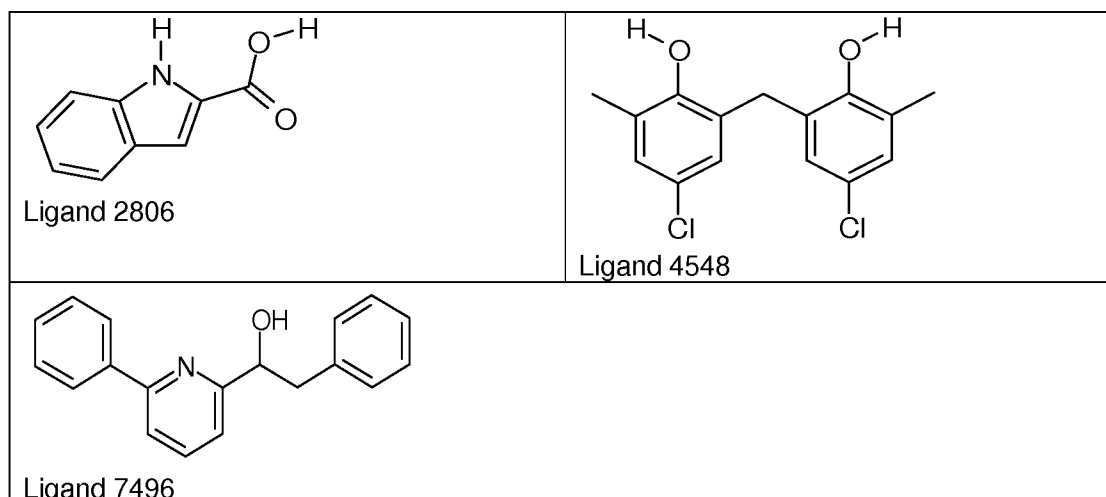

**[0049]** Various ligands useful herein and in the tables above are commercially available (*e.g.*, from vendors such as American Custom Chemical Corporation of San Diego, California, U.S.A., Alfa Aesar of Ward Hill, Massachusetts, U.S.A., Ambinter of Paris, France, Anthem

5 Pharmaceutical Research LLC of Newington, Connecticut, U.S.A., ChemBridge Corporation of San Diego, California, U.S.A., Combi-Blocks of San Diego, California, U.S.A., Gelest, Inc. of Morrisville, Pennsylvania, U.S.A., Interchim, Inc. of San Pedro, California, U.S.A., Maybridge Chemical Co., Ltd. of Belgium, Princeton Biomolecular Research, Inc. of Princeton, New Jersey, U.S.A., Sigma-Aldrich, Inc. of St. Louis, Missouri, U.S.A., Strem Chemicals, Inc. of  
10 Newburyport, Massachusetts, U.S.A., TCI America of Portland, Oregon, U.S.A., and from VWR International, LLC, of Radnor, Pennsylvania, U.S.A.) and/or can be prepared using conventional synthetic methods in organic chemistry.

**[0050]** Ingredient (A) may be prepared by a method comprising combining a ligand and a Re precursor, described above. The method may optionally further comprise a step of dissolving  
15 either the Re precursor, or the ligand, or both, in a solvent before combining the Re precursor and the ligand. Suitable solvents are exemplified by those described below for ingredient (S). Alternatively, the ligand may be dissolved in a solvent in a container, and the solvent may thereafter be removed before adding the Re precursor to the container with the ligand. The amounts of ligand and Re precursor are selected such that the mole ratio of ligand to Re  
20 precursor (Metal: Ligand Ratio) may range from 10:1 to 1:10, alternatively 2:1 to 1:2, alternatively 1:1 to 1:4, and alternatively 1:1 to 1:2. Combining the Re precursor and the ligand may be performed by any convenient means, such as mixing them together in or shaking the container.

**[0051]** Reacting the Re precursor and ligand may be performed by under any convenient  
25 conditions such as allowing the Re precursor and ligand prepared as described above to react at -80 °C to 200 °C, alternatively room temperature (RT) of 25 °C for a period of time, by heating, or a combination thereof. Heating may be performed at, for example greater than 25 °C to 200 °C, alternatively greater than 25 °C to 75 °C. Heating may be performed by any convenient means, such as via a heating mantle, heating coil, or placing the container in an oven. The  
30 complexation reaction temperature depends on various factors including the reactivities of the specific Re precursor and ligand selected and the Metal : Ligand Ratio, however, temperature may range from 25 °C to 200 °C, alternatively 25 °C to 75 °C. Complexation reaction time depends on various factors including the reaction temperature selected, however, complexation reaction time may typically range from 1 second (s) to 48 hours (h), alternatively 1 minute (min)  
35 to 30 hours (h), and alternatively 45 min to 15 h. The ligand and Re precursor may be combined and heated sequentially. Alternatively, the ligand and Re precursor may be combined and heated concurrently.

**[0052]** The method of preparing the catalytically active reaction product of ingredient (A) may further comprise activating the reaction product prepared as described above. Activating the reaction product can be performed by reducing the formal oxidation state of the metal atom in the Re-ligand complex by combining the reaction product described above with a reducing agent. Examples of reducing agents that may be combined with the reaction product include an alkalimetal amalgam; hydrogen, a metal hydride such as lithium aluminum hydride (LiAlH<sub>4</sub>) or sodium naphthalenide; a silyl hydride (which may be in addition to, or instead of, all or a portion of a silane crosslinker, described below); or a metal borohydride such as sodium triethylborohydride (NaEt<sub>3</sub>BH), lithium triethylborohydride (LiEt<sub>3</sub>BH), or sodium borohydride (NaBH<sub>4</sub>). Suitable reducing agents include those described in Chem. Rev. 1996, 96, 877-910.

**[0053]** Alternatively, the reaction product described above can be activated by a process comprising combining the reaction product described above with an ionic activator. Examples of ionic activators for use in this process include carboranes, such as Li<sup>+</sup>[CB<sub>11</sub>H<sub>6</sub>Br<sub>6</sub>]<sup>-</sup>, Li<sup>+</sup>[CB<sub>9</sub>H<sub>5</sub>Br<sub>5</sub>]<sup>-</sup>, Li<sup>+</sup>[CB<sub>11</sub>H<sub>10</sub>Br<sub>2</sub>]<sup>-</sup>, and Li<sup>+</sup>[CB<sub>9</sub>H<sub>8</sub>Br<sub>2</sub>]<sup>-</sup>, NH<sub>4</sub><sup>+</sup>[CB<sub>11</sub>H<sub>6</sub>Br<sub>6</sub>]<sup>-</sup>, NH<sub>4</sub><sup>+</sup>[CB<sub>9</sub>H<sub>5</sub>Br<sub>5</sub>]<sup>-</sup>, NH<sub>4</sub><sup>+</sup>[CB<sub>11</sub>H<sub>10</sub>Br<sub>2</sub>]<sup>-</sup>, NH<sub>4</sub><sup>+</sup>[CB<sub>9</sub>H<sub>8</sub>Br<sub>2</sub>]<sup>-</sup>, Na<sup>+</sup>[CB<sub>11</sub>H<sub>6</sub>Br<sub>6</sub>]<sup>-</sup>, Na<sup>+</sup>[CB<sub>9</sub>H<sub>5</sub>Br<sub>5</sub>]<sup>-</sup>, Na<sup>+</sup>[CB<sub>11</sub>H<sub>10</sub>Br<sub>2</sub>]<sup>-</sup>, and Na<sup>+</sup>[CB<sub>9</sub>H<sub>8</sub>Br<sub>2</sub>]<sup>-</sup>; or metal borates such as lithium tetrakis(pentafluorophenyl)borate (LiBARf), lithium tetrakis(3,5-trifluoromethyl)phenylborate, sodium tetrakis(3,5-trifluoromethyl)phenylborate, or a mixture thereof.

**[0054]** Alternatively, the reduction product described above can be activated by a method comprising combining the reaction product described above with a neutral activator. Examples of neutral activators for use in this method include tris(pentafluorophenyl)borane and tris(pentafluorophenyl)allane.

**[0055]** The method of preparing the catalytically active reaction product of ingredient (A) may optionally further comprise adding a solvent after the reaction. Suitable solvents are exemplified by those described below for ingredient (S). Alternatively, the method may optionally further comprise removing a reaction by-product and/or the solvent, if the solvent is present (e.g., used to facilitate combination of the Re precursor and the ligand before or during the complexation reaction. By-products include, for example, H-A (where A is as defined above in general formula (i)) or any species resulting from reacting a displaceable substituent off the Re precursor when the ligand reacts with the Re precursor. By-products may be removed by any convenient means, such as stripping or distillation, with heating or under vacuum, and/or filtration, crystallization, or a combination thereof. The resulting isolated Re-ligand complex may be used as the catalytically active reaction product of ingredient (A).

**[0056]** Alternatively, the reaction by-products are not removed before using the catalytically active reaction product as ingredient (A). For example, the ligand and Re precursor may be

reacted as described above, with or without solvent removal, and with or without activation, and the resulting reaction product (comprising the Re-ligand complex and the reaction by-product and optionally a solvent or diluent) may be used as ingredient (A). Without wishing to be bound by theory, it is thought that a by-product may act as a hydrosilylation reaction catalyst, or as a  
5 co-catalyst or an activator, in addition to the Re-ligand complex. Therefore, the reaction product may catalyze a hydrosilylation reaction.

**[0057]** The composition may contain one single catalyst. Alternatively, the composition may comprise two or more catalysts described above as ingredient (A), where the two or more catalysts differ in at least one property such as selection of ligand, selection of precursor, Metal:  
10 Ligand Ratio, and definitions for group A in general formula (i). The composition may be free of platinum catalysts. Alternatively, the composition may be free of conventional metal catalysts. Alternatively, the composition may be free of any Re compound that would catalyze the hydrosilylation reaction of the unsaturated groups on ingredient (B) other than the ingredient (A). Alternatively, the composition may be free of hydrosilylation reaction catalysts other than  
15 ingredient (A). Alternatively, the composition may be free of any ingredient that would catalyze the hydrosilylation reaction of the unsaturated groups on ingredient (B) other than ingredient (A).

**[0058]** Ingredient (A) is present in the composition in a catalytically effective amount. The exact amount depends on various factors including reactivity of ingredient (A), the type and  
20 amount of ingredient (B), and the type and amount of any additional ingredient, if present. However, the amount of ingredient (A) in the composition may range from 1 part per million (ppm) to 5 %, alternatively 0.1 % to 2 %, and alternatively 1 ppm to 1 %, based on total weight of all ingredients in the composition.

**[0059]** Ingredient (B) is an aliphatically unsaturated compound having an average, per  
25 molecule, of one or more aliphatically unsaturated organic groups capable of undergoing hydrosilylation reaction. Alternatively, ingredient (B) may have an average of two or more aliphatically unsaturated organic groups per molecule. The aliphatically unsaturated organic groups may be alkenyl exemplified by, but not limited to, vinyl, allyl, propenyl, butenyl, and hexenyl. The unsaturated organic groups may be alkynyl groups exemplified by, but not limited  
30 to, ethynyl, propynyl, and butynyl.

**[0060]** Ingredient (B) of the composition may be an unsaturated hydrocarbon, where the unsaturated group is capable of reacting via hydrosilylation reaction. Ingredient (B) may be monomeric. For example, suitable aliphatically unsaturated organic compounds for ingredient (B) include, but are not limited to alkenes such as ethylene, propene, 1-butene, 2-butene, 1-  
35 pentene, 1-hexene, 1-heptene; halogenated alkenes, such as allyl chloride; diolefins such as

divinylbenzene, butadiene, 1,5-hexadiene, and 1-buten-3-yne; cycloolefins such as cyclohexene and cycloheptene; and alkynes such as acetylene, propyne, and 1-hexyne.

**[0061]** Oxygen-containing aliphatically unsaturated compounds can also be used for ingredient (B), for example, where the unsaturation is ethylenic, such as vinylcyclohexyl

5 epoxide, allyl glycidyl ether, methylvinyl ether, divinylether, phenylvinyl ether, monoallyl ether of ethylene glycol, allyl aldehyde, methylvinyl ketone, phenylvinyl ketone, acrylic acid, methacrylic acid, methyl acrylate, allyl acrylate, methyl methacrylate, allyl methacrylate, vinylacetic acid, vinyl acetate, and linolenic acid.

**[0062]** Heterocyclic compounds containing aliphatic unsaturation in the ring, such as

10 dihydrofuran, and dihydropyran, are also suitable as ingredient (B). Unsaturated compounds containing nitrogen substituents such as acrylonitrile, N-vinylpyrrolidone, alkyl cyanide, nitroethylene are also suitable as ingredient (B).

**[0063]** Alternatively, ingredient (B) of the composition comprise a polymer. Ingredient (B)

15 may comprise a base polymer having an average of one or more aliphatically unsaturated organic groups, capable of undergoing a hydrosilylation reaction, per molecule. Ingredient (B) may comprise a polymer (*e.g.*, copolymers or terpolymers) of the various compounds described above, provided there is at least one aliphatic unsaturation capable of undergoing a hydrosilylation reaction. Examples include polymers derived from olefinic monomers having 2 to 20 carbon atoms and dienes having 4 to 20 carbon atoms; polymers of monoolefin, 20 isomonoolefin and vinyl aromatic monomers, such as monoolefins having 2 to 20 carbon groups, isomonoolefins having 4 to 20 carbon groups, and vinyl aromatic monomers including styrene, para-alkylstyrene, para-methylstyrene. Alternatively, the compounds can be poly(dienes). Most polymers derived from dienes usually contain unsaturated ethylenic units on backbone or side-chains. Representative examples include polybutadiene, polyisoprene, 25 polybutenylene, poly(alkyl-butenylene) where alkyl includes alkyl groups having 1 to 20 carbon atoms, poly(phenyl-butenylene), polypentenylene, natural rubber (a form of polyisoprene); and butyl rubber (copolymer of isobutylene and isoprene).

**[0064]** Alternatively, ingredient (B) may comprise a halogenated olefin polymer having aliphatic unsaturation. Representative examples of a halogenated olefin polymer having

30 aliphatic unsaturation include polymers resulting from the bromination of a copolymer of isomonoolefin with para-methylstyrene to introduce benzylic halogen, halogenated polybutadienes, halogenated polyisobutylene, poly(2-chloro-1,3-butadiene), polychloroprene (85% trans), poly(1-chloro-1-butenylene) (Neoprene®), and chlorosulfonated polyethylene.

**[0065]** Alternatively, ingredient (B) may comprise polymers containing other compounds

35 described above such as vinyl ether groups, acrylate groups, methacrylate groups, and epoxy-functional groups.

**[0066]** Alternatively, ingredient (B) may comprise a silane having aliphatic unsaturation. Alternatively the silane may have a general formula of  $R^{35}_{xx}SiR^{36}_{(4-xx)}$  where subscript xx is an integer from 1 to 4, alternatively 1 to 3, and alternatively 1.  $R^{35}$  is an aliphatically unsaturated organic group, and  $R^{36}$  is selected from H, a halogen atom, and a monovalent organic group.

**[0067]** Alternatively, ingredient (B) may comprise a silicon containing base polymer having a linear, branched, cyclic, or resinous structure having aliphatic unsaturation. Alternatively, the base polymer may have a linear and/or branched structure. Alternatively, the base polymer may have a resinous structure. The base polymer may be a homopolymer or a copolymer.

Ingredient (B) may be one base polymer. Alternatively, ingredient (B) may comprise two or more base polymers differing in at least one of the following properties: structure, viscosity, average molecular weight, siloxane units, and sequence. The aliphatically unsaturated organic groups in the base polymer may be located at terminal, pendant, or both terminal and pendant positions.

**[0068]** The remaining silicon-bonded organic groups in the base polymer for ingredient (B) may be monovalent organic groups free of aliphatic unsaturation. Examples of monovalent hydrocarbon groups include, but are not limited to, alkyl such as Me, Et, Pr, Bu, pentyl, hexyl, heptyl, octyl, decyl, dodecyl, undecyl, and octadecyl; cycloalkyl such as cyclopentyl and cyclohexyl; aryl such as Ph, tolyl, xylyl, and naphthyl; and aralkyl such as benzyl, 1-phenylethyl and 2-phenylethyl. Examples of monovalent halogenated hydrocarbon groups include, but are not limited to, chlorinated alkyl groups such as chloromethyl and chloropropyl groups; fluorinated alkyl groups such as fluoromethyl, 2-fluoropropyl, 3,3,3-trifluoropropyl, 4,4,4-trifluorobutyl, 4,4,4,3,3-pentafluorobutyl, 5,5,5,4,4,3,3-heptafluoropentyl, 6,6,6,5,5,4,4,3,3-nonafluorohexyl, and 8,8,8,7,7-pentafluorooctyl; chlorinated cycloalkyl groups such as 2,2-dichlorocyclopropyl, 2,3-dichlorocyclopentyl; and fluorinated cycloalkyl groups such as 2,2-difluorocyclopropyl, 2,3-difluorocyclobutyl, 3,4-difluorocyclohexyl, and 3,4-difluoro-5-methylcycloheptyl. Examples of other monovalent organic groups include, but are not limited to, hydrocarbon groups substituted with oxygen atoms such as glycidoxyalkyl, and hydrocarbon groups substituted with nitrogen atoms such as aminoalkyl and cyano-functional groups such as cyanoethyl and cyanopropyl.

**[0069]** Ingredient (B) may comprise a polydiorganosiloxane of

Formula (I):  $R^1_2R^2SiO(R^1_2SiO)_a(R^1R^2SiO)_bSiR^1_2R^2$ ,

Formula (II):  $R^1_3SiO(R^1_2SiO)_c(R^1R^2SiO)_dSiR^1_3$ ,

or a combination thereof.

**[0070]** In formulae (I) and (II), each  $R^1$  is independently a hydrogen atom or a monovalent organic group free of aliphatic unsaturation and each  $R^2$  is independently an aliphatically unsaturated organic group, exemplified by those described above. Subscript a may be 0 or a positive number. Alternatively, subscript a has an average value of at least 2. Alternatively,

5

subscript a may have a value ranging from 2 to 2000. Subscript b may be 0 or a positive number. Alternatively, subscript b may have an average value ranging from 0 to 2000. Subscript c may be 0 or a positive number. Alternatively, subscript c may have an average value ranging from 0 to 2000. Subscript d has an average value of at least 2. Alternatively

10

subscript d may have an average value ranging from 2 to 2000. Suitable monovalent organic groups for  $R^1$  are as described above for ingredient (B). Alternatively, each  $R^1$  is a monovalent hydrocarbon group exemplified by alkyl such as Me and aryl such as Ph. Each  $R^2$  is independently an aliphatically unsaturated monovalent organic group as described above for ingredient (B). Alternatively,  $R^2$  is exemplified by alkenyl groups such as vinyl, allyl, butenyl, and hexenyl; and alkynyl groups such as ethynyl and propynyl.

15

**[0071]** Ingredient (B) may comprise a polydiorganosiloxane such as

i) dimethylvinylsiloxy-terminated polydimethylsiloxane,

ii) dimethylvinylsiloxy-terminated poly(dimethylsiloxane/methylvinylsiloxane),

iii) dimethylvinylsiloxy-terminated polymethylvinylsiloxane,

iv) trimethylsiloxy-terminated poly(dimethylsiloxane/methylvinylsiloxane),

20

v) trimethylsiloxy-terminated polymethylvinylsiloxane,

vi) dimethylvinylsiloxy-terminated poly(dimethylsiloxane/methylvinylsiloxane),

vii) dimethylvinylsiloxy-terminated poly(dimethylsiloxane/methylphenylsiloxane),

viii) dimethylvinylsiloxy-terminated poly(dimethylsiloxane/diphenylsiloxane),

ix) phenyl,methyl,vinyl-siloxy-terminated polydimethylsiloxane,

25

x) dimethylhexenylsiloxy-terminated polydimethylsiloxane,

xi) dimethylhexenylsiloxy-terminated poly(dimethylsiloxane/methylhexenylsiloxane),

xii) dimethylhexenylsiloxy-terminated polymethylhexenylsiloxane,

xiii) trimethylsiloxy-terminated poly(dimethylsiloxane/methylhexenylsiloxane),

xiv) trimethylsiloxy-terminated polymethylhexenylsiloxane

30

xv) dimethylhexenyl-siloxy terminated poly(dimethylsiloxane/methylhexenylsiloxane),

xvi) dimethylvinylsiloxy-terminated poly(dimethylsiloxane/methylhexenylsiloxane)

xvii) a combination thereof.

**[0072]** Methods of preparing polydiorganosiloxane fluids suitable for use as ingredient (B), such as hydrolysis and condensation of the corresponding organohalosilanes or equilibration of cyclic polydiorganosiloxanes, are well known in the art.

35

[0073] In addition to, or instead of, the polydiorganosiloxane described above, ingredient (B) may further comprise a resin such as an MQ resin consisting essentially of  $R^3_3SiO_{1/2}$  units and  $SiO_{4/2}$  units, a TD resin consisting essentially of  $R^3SiO_{3/2}$  units and  $R^3_2SiO_{2/2}$  units, an MT resin consisting essentially of  $R^3_3SiO_{1/2}$  units and  $R^3SiO_{3/2}$  units, an MTD resin  
5 consisting essentially of  $R^3_3SiO_{1/2}$  units,  $R^3SiO_{3/2}$  units, and  $R^3_2SiO_{2/2}$  units, or a combination thereof.

[0074] Each  $R^3$  is a monovalent organic group exemplified by those described above for ingredient (B). Alternatively, the monovalent organic groups represented by  $R^3$  may have 1 to 20 carbon atoms. Alternatively, examples of monovalent organic groups for  $R^3$  include, but are  
10 not limited to, monovalent hydrocarbon groups and monovalent halogenated hydrocarbon groups.

[0075] The resin may contain an average of 3 to 30 mole percent of aliphatically unsaturated organic groups, alternatively 0.1 to 30 mole percent, alternatively 0.1 to 5 mole percent, alternatively 3 to 100 mole percent. The aliphatically unsaturated organic groups may be  
15 alkenyl groups, alkynyl groups, or a combination thereof. The mole percent of aliphatically unsaturated organic groups in the resin is the ratio of the number of moles of unsaturated group-containing siloxane units in the resin to the total number of moles of siloxane units in the resin, multiplied by 100.

[0076] Methods of preparing resins are well known in the art. For example, resin may be  
20 prepared by treating a resin copolymer produced by the silica hydrosol capping process of Daudt, *et al.* with at least an alkenyl-containing endblocking reagent. The method of Daudt *et al.*, is disclosed in U.S. Patent 2,676,182.

[0077] The method of Daudt, *et al.* involves reacting a silica hydrosol under acidic conditions with a hydrolyzable triorganosilane such as trimethylchlorosilane, a siloxane such as  
25 hexamethyldisiloxane, or mixtures thereof, and recovering a copolymer having M-units and Q-units. The resulting copolymers generally contain from 2 to 5 percent by weight of hydroxyl groups.

[0078] The resin, which typically contains less than 2 % of silicon-bonded hydroxyl groups, may be prepared by reacting the product of Daudt, *et al.* with an unsaturated organic group-  
30 containing endblocking agent and an endblocking agent free of aliphatic unsaturation, in an amount sufficient to provide from 3 to 30 mole percent of unsaturated organic groups in the final product. Examples of endblocking agents include, but are not limited to, silazanes, siloxanes, and silanes. Suitable endblocking agents are known in the art and exemplified in U.S. Patents

4,584,355; 4,591,622; and 4,585,836. A single endblocking agent or a mixture of such agents may be used to prepare the resin.

**[0079]** Alternatively, ingredient (B) may comprise a silicon containing base polymer other than the polyorganosiloxanes described above. For example, other compounds suitable for

ingredient (B) include silazanes and/or polymeric materials containing silicon atoms joined together by hydrocarbyl groups such as alkylene or polyalkylene groups or arylene groups.

The silicon-modified organic compounds useful as ingredient (B) include organic polymers having at least one silicon atom attached as a silane or a siloxane segment. The silicon-

containing units can contain aliphatic unsaturation and can be attached at the terminal and/or

pendant positions on the organic polymer chain or as a copolymer. Other representative

silicon-modified organic polymers for ingredient (B) are exemplified by, but not limited to

alkenylsiloxyl-functional polymers such as vinylsiloxyl-, allylsiloxyl-, and hexenylsiloxyl- organic polymers and siloxane-organic block copolymers. Examples of silane-modified organic

polymers are silylated polymers derived from olefins, isomonoolefin, dienes, ethylene or

propylene oxides, and vinyl aromatic monomers having 2 to 20 carbon atoms such as the silane-grafted copolymers of isomonoolefin and vinyl aromatic monomers.

**[0080]** Examples of silicon-modified organic polymers described by above include vinylsiloxyl-terminated or hexenylsiloxyl-terminated poly(dimethylsiloxane/hydrocarbyl)

copolymers, vinylsiloxyl-terminated or hexenylsiloxyl-terminated

poly(dimethylsiloxane/polyoxyalkylene) block copolymers, alkenyloxydimethylsiloxyl-terminated polyisobutylene and alkenyloxydimethylsiloxyl-terminated polydimethylsiloxane/polyisobutylene

block copolymers. Examples of suitable compounds for ingredient (B) may be found, for example, in WO 2003/093369.

**[0081]** The amount of ingredient (B) in the composition depends on various factors including

the desired form of the reaction product of the composition, the quantity and hydrosilylation

reactivity of the aliphatically unsaturated groups of ingredient (B), the type and amount of

ingredient (A), and the content of silicon bonded hydrogen atoms of, ingredient (B) and/or

ingredient (C). However, the amount of ingredient (B) may range from 0.1 % to 99.9 % based on the weight of all ingredients in the composition.

**[0082]** Ingredient (C) in the composition is a SiH functional compound, *i.e.*, a compound

having an average, per molecule, of one or more silicon bonded hydrogen atoms. Ingredient

(C) may comprise a silane and/or an organohydrogensilicon compound. Alternatively,

ingredient (C) may have an average, per molecule, of at least two silicon-bonded hydrogen

atoms. The amount of ingredient (C) in the composition depends on various factors including

the SiH content of ingredient (C), the unsaturated group content of ingredient (B), and the

properties of the reaction product of the composition desired, however, the amount of ingredient

(C) may be sufficient to provide a molar ratio of SiH groups in ingredient (C) to aliphatically unsaturated organic groups in ingredient (B) (commonly referred to as the SiH:Vi ratio) ranging from 0.3:1 to 5:1, alternatively 0.1:10 to 10:1. Ingredient (C) can have a monomeric or polymeric structure. When ingredient (C) has a polymeric structure, the polymeric structure may be linear, branched, cyclic, or resinous structure. When ingredient (C) is polymeric, then ingredient (C) can be a homopolymer or a copolymer. The silicon-bonded hydrogen atoms in ingredient (C) can be located at terminal, pendant, or at both terminal and pendant positions. Ingredient (C) may be one SiH functional compound. Alternatively, ingredient (C) may comprise a combination of two or more SiH functional compounds. Ingredient (C) may be two or more organohydrogenpolysiloxanes that differ in at least one of the following properties: structure, average molecular weight, viscosity, siloxane units, and sequence.

**[0083]** Ingredient (C) may comprise a silane of formula  $R^4_eSiH_f$ , where subscript e is 0, 1, 2, or 3; subscript f is 1, 2, 3, or 4, with the proviso that a sum of (e + f) is 4. Each  $R^4$  is independently a halogen atom or a monovalent organic group. Suitable halogen atoms for  $R^4$  are exemplified by chlorine, fluorine, bromine, and iodine; alternatively chlorine. Suitable monovalent organic groups for  $R^4$  include, but are not limited to, monovalent hydrocarbon and monovalent halogenated hydrocarbon groups. Monovalent hydrocarbon groups include, but are not limited to, alkyl such as Me, Et, Pr, Bu, pentyl, hexyl, heptyl, octyl, decyl, dodecyl, undecyl, and octadecyl; cycloalkyl such as cyclopentyl and cyclohexyl; aryl such as Ph, tolyl, xylyl, and naphthyl; and aralkyl such as benzyl, 1-phenylethyl and 2-phenylethyl. Examples of monovalent halogenated hydrocarbon groups include, but are not limited to, chlorinated alkyl groups such as chloromethyl and chloropropyl groups; fluorinated alkyl groups such as fluoromethyl, 2-fluoropropyl, 3,3,3-trifluoropropyl, 4,4,4-trifluorobutyl, 4,4,4,3,3-pentafluorobutyl, 5,5,5,4,4,3,3-heptafluoropentyl, 6,6,6,5,5,4,4,3,3-nonafluorohexyl, and 8,8,8,7,7-pentafluorooctyl; chlorinated cycloalkyl groups such as 2,2-dichlorocyclopropyl, 2,3-dichlorocyclopentyl; and fluorinated cycloalkyl groups such as 2,2-difluorocyclopropyl, 2,3-difluorocyclobutyl, 3,4-difluorocyclohexyl, and 3,4-difluoro-5-methylcycloheptyl. Examples of other monovalent organic groups include, but are not limited to, hydrocarbon groups substituted with oxygen atoms such as glycidoxyalkyl, and alkoxy groups such as methoxy, ethoxy, propoxy, and butoxy; and hydrocarbon groups substituted with nitrogen atoms such as aminoalkyl and cyano-functional groups such as cyanoethyl and cyanopropyl. Examples of suitable silanes for ingredient (C) are exemplified by trichlorosilane ( $HSiCl_3$ ),  $Me_2HSiCl$ , or  $MeHSi(OMe)_2$ .

**[0084]** Alternatively, the organohydrogensilicon compound of ingredient (C) may comprise a polyorganohydrogensiloxane comprising siloxane units including, but not limited to,

HR<sup>5</sup><sub>2</sub>SiO<sub>1/2</sub>, R<sup>5</sup><sub>3</sub>SiO<sub>1/2</sub>, HR<sup>5</sup>SiO<sub>2/2</sub>, R<sup>5</sup><sub>2</sub>SiO<sub>2/2</sub>, R<sup>5</sup>SiO<sub>3/2</sub>, HSiO<sub>3/2</sub> and SiO<sub>4/2</sub> units. In the preceding formulae, each R<sup>5</sup> is independently selected from the monovalent organic groups free of aliphatic unsaturation described above.

[0085] Ingredient (C) may comprise a polyorganohydrogensiloxane of

5 Formula (III): R<sup>5</sup><sub>3</sub>SiO(R<sup>5</sup><sub>2</sub>SiO)<sub>g</sub>(R<sup>5</sup>HSiO)<sub>h</sub>SiR<sup>5</sup><sub>3</sub>,

Formula (IV): R<sup>5</sup><sub>2</sub>HSiO(R<sup>5</sup><sub>2</sub>SiO)<sub>i</sub>(R<sup>5</sup>HSiO)<sub>j</sub>SiR<sup>5</sup><sub>2</sub>H, or

a combination thereof.

[0086] In formulae (III) and (IV) above, subscript g has an average value ranging from 0 to 2000, subscript h has an average value ranging from 2 to 2000, subscript i has an average value ranging from 0 to 2000, and subscript j has an average value ranging from 0 to 2000.

Each R<sup>5</sup> is independently a monovalent organic group, as described above.

[0087] Polyorganohydrogensiloxanes for ingredient (C) are exemplified by:

- a) dimethylhydrogensiloxy-terminated polydimethylsiloxane,
- b) dimethylhydrogensiloxy-terminated poly(dimethylsiloxane/methylhydrogensiloxane),
- 15 c) dimethylhydrogensiloxy-terminated polymethylhydrogensiloxane,
- d) trimethylsiloxy-terminated poly(dimethylsiloxane/methylhydrogensiloxane),
- e) trimethylsiloxy-terminated polymethylhydrogensiloxane,
- f) a resin consisting essentially of H(CH<sub>3</sub>)<sub>2</sub>SiO<sub>1/2</sub> units and SiO<sub>4/2</sub> units, and
- g) a combination thereof.

[0088] Methods of preparing linear, branched, and cyclic organohydrogenpolysiloxanes suitable for use as ingredient (C), such as hydrolysis and condensation of organohalosilanes, are well known in the art. Methods of preparing organohydrogenpolysiloxane resins suitable for use as ingredient (C) are also well known as exemplified in U.S. Patents 5,310,843; 4,370,358; and 4,707,531.

[0089] Alternatively, the organohydrogensilicon compound of ingredient (C) may comprise a compound of formula (V):

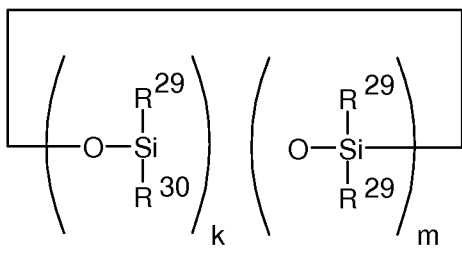

where each R<sup>29</sup> is independently selected from a hydrogen atom and a monovalent organic group comprising 1 to 20 member atoms, subscript k is an integer with a value ranging from 4 to 18, subscript m is an integer with a value ranging from 0 to 19, k + m is an integer with a

value ranging from 3 to 20, alternatively 3 to 40. Each R<sup>30</sup> is independently selected from a monovalent organic group a halogen atom or a siloxane unit as described in the sections above. Alternatively each R<sup>30</sup> is a functional group independently selected from a halogen atom, an ether group, an alkoxy group, an alkoxyether group, an acyl group, an epoxy group, an amino group, a silyl group, or a -Z-R<sup>31</sup> group, where each Z is independently selected from an oxygen atom and a divalent hydrocarbon group comprising 2 to 20 carbon atoms, each R<sup>31</sup> group is independently selected from -BR<sup>29</sup><sub>u</sub> R<sup>32</sup><sub>2-u</sub>, -Si R<sup>29</sup><sub>v</sub> R<sup>32</sup><sub>3-v</sub>, or a group described by formula (VI):

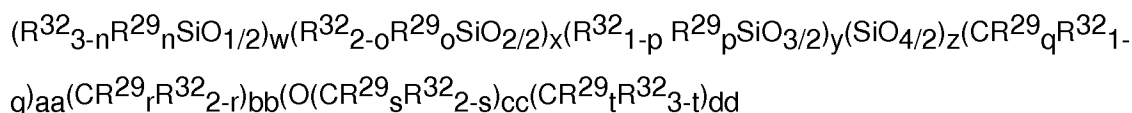

where B refers to boron, each R<sup>29</sup> is as described above, the sum of w+x+y+z+aa+bb+cc+dd is at least 2, subscript n is an integer with a value ranging from 0 to 3, subscript o is an integer with a value ranging from 0 to 2, subscript p is an integer with a value ranging from 0 to 1, subscript q is an integer with a value ranging from 0 to 1, subscript r is an integer with a value ranging from 0 to 2, subscript s is an integer with a value ranging from 0 to 2, subscript t is an integer with a value ranging from 0 to 3, subscript u is an integer with a value ranging from 0 to 2, subscript v is an integer with a value ranging from 0 to 3, each R<sup>32</sup> is a functional group independently selected from a halogen atom, an ether group, an alkoxy group, an alkoxyether group, an acyl group, an epoxy group, an amino group, a silyl group, or a Z-G group, where Z is as described above, each G is a cyclosiloxane described by formula (VII):

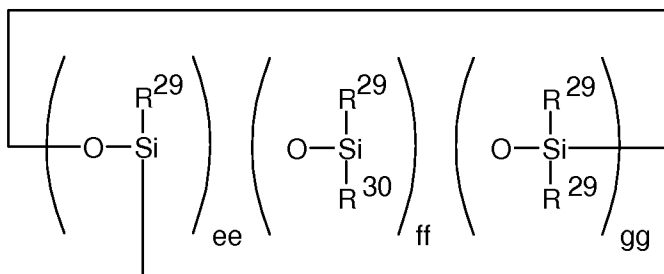

where R<sup>29</sup> and R<sup>30</sup> are as described above, subscript ee is 1, subscript ff is an integer with a value ranging from 0 to 18, subscript gg is an integer with a value ranging from 0 to 18, ff+gg is an integer with a value ranging from 2 to 20, provided in formula (VII) that one of the R<sup>32</sup> groups is replaced by the Z group bonding the R<sup>31</sup> group to the cyclosiloxane of formula (VII), and provided further if aa+bb+cc+dd>0 then w+x+y+z>0.

**[0090]** Such organohydrogensilicon compounds are commercially available and include, SYL-OFF® SL2 CROSSLINKER and SYL-OFF® SL12 CROSSLINKER, both of which are commercially available from Dow Corning Corporation of Midland, Michigan, U.S.A. The organohydrogensilicon compounds described above and methods for their preparation are exemplified in WO2003/093349 and WO2003/093369. An exemplary organohydrogensilicon compound may have the general formula:

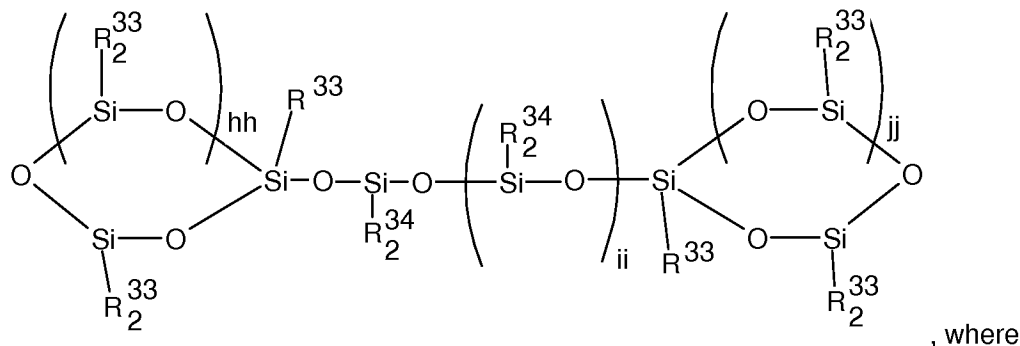

each R<sup>33</sup> is independently selected from a hydrogen atom and a monovalent organic group; each R<sup>34</sup> is independently selected from a hydrogen atom, a monovalent organic group, and a

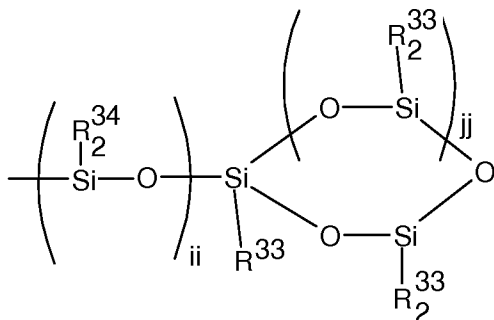

group of formula ; subscript hh is an integer with a value of at least 1; subscript jj is an integer with a value of at least 1; and subscript ii is an integer with a minimum value of 0. In the general formula, at least one instance of R<sup>33</sup> is a hydrogen atom. Suitable monovalent organic groups for R<sup>33</sup> and/or R<sup>34</sup> are exemplified by those groups described above for R<sup>29</sup>.

**[0091]** The exact amount of ingredient (C) in the composition depends on various factors including reactivity of ingredient (A), the type and amount of ingredient (B), whether ingredient (B) contains a silicon bonded hydrogen atom, and the type and amount of any additional ingredient (other than ingredient (C)), if present. However, the amount of ingredient (C) in the composition may range from 0 % to 25 %, alternatively 0.1 % to 15 %, and alternatively 1 % to 5 %, based on total weight of all ingredients in the composition.

**[0092]** Ingredient (D) is a spacer. Spacers can comprise organic particles, inorganic particles, or a combination thereof. Spacers can be thermally conductive, electrically

conductive, or both. Spacers can have a desired particle size, for example, particle size may range from 25 micrometers ( $\mu\text{m}$ ) to 125  $\mu\text{m}$ . Spacers can comprise monodisperse beads, such as glass or polymer (e.g., polystyrene) beads. Spacers can comprise thermally conductive fillers such as alumina, aluminum nitride, atomized metal powders, boron nitride, copper, and silver. The amount of ingredient (D) depends on various factors including the particle size distribution, pressure to be applied during use of the composition or the cured product prepared therefrom, temperature during use, and desired thickness of the composition or the cured product prepared therefrom. However, the composition may contain an amount of ingredient (D) ranging from 0.05 % to 2 %, alternatively 0.1 % to 1 %.

- 10 **[0093]** Ingredient (E) is an extender and/or a plasticizer. An extender comprising a non-functional polyorganosiloxane may be used in the composition. For example, the non-functional polyorganosiloxane may comprise difunctional units of the formula  $\text{R}^6_2\text{SiO}_{2/2}$  and terminal units of the formula  $\text{R}^7_3\text{SiR}^{28}$ , where each  $\text{R}^6$  and each  $\text{R}^7$  are independently a monovalent organic group such as a monovalent hydrocarbon group exemplified by alkyl such as methyl, ethyl, propyl, and butyl; alkenyl such as vinyl, allyl, and hexenyl; aryl such as Ph, tolyl, xylyl, and naphthyl; and aralkyl groups such as phenylethyl; and  $\text{R}^{28}$  is an oxygen atom or a divalent group linking the silicon atom of the terminal unit with another silicon atom. The divalent linking group for  $\text{R}^{28}$  may be a divalent organic group, a silicone organic group, or a combination of a divalent hydrocarbon group and a divalent siloxane group. Alternatively, each  $\text{R}^{28}$  may be independently selected from an oxygen atom and a divalent hydrocarbon group. Alternatively, each  $\text{R}^{28}$  may be an oxygen atom. Alternatively, each  $\text{R}^{28}$  may be a divalent hydrocarbon group exemplified by an alkylene group such as ethylene, propylene, butylene, or hexylene; an arylene group such as phenylene, or an alkylarylene group such as:

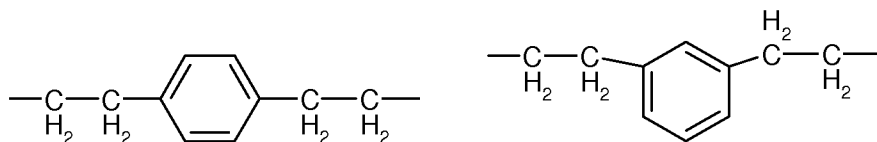

. Alternatively, an

- 25 instance of  $\text{R}^{28}$  may be an oxygen atom while a different instance of  $\text{R}^{28}$  is a divalent hydrocarbon group. Non-functional polyorganosiloxanes are known in the art and are commercially available. Suitable non-functional polyorganosiloxanes are exemplified by, but not limited to, polydimethylsiloxanes. Such polydimethylsiloxanes include DOW CORNING® 200 Fluids, which are commercially available from Dow Corning Corporation of Midland, Michigan, U.S.A. and may have viscosity ranging from 50 cSt to 100,000 cSt, alternatively 50 cSt to 50,000 cSt, and alternatively 12,500 cSt to 60,000 cSt.

**[0094]** An organic plasticizer may be used in addition to, or instead of, the non-functional polyorganosiloxane extender described above. Organic plasticizers are known in the art and are commercially available. The organic plasticizer may comprise a phthalate, a carboxylate, a carboxylic acid ester, an adipate or a combination thereof. The organic plasticizer may be selected from the group consisting of: bis(2-ethylhexyl) terephthalate; bis(2-ethylhexyl)-1,4-benzenedicarboxylate; 2-ethylhexyl methyl-1,4-benzenedicarboxylate; 1,2-cyclohexanedicarboxylic acid, dinonyl ester, branched and linear; bis(2-propylheptyl) phthalate; diisononyl adipate; and a combination thereof.

**[0095]** The organic plasticizer may have an average, per molecule, of at least one group of

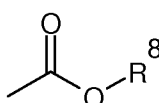
formula , where R<sup>8</sup> represents a hydrogen atom or a monovalent organic group.

Alternatively, R<sup>8</sup> may represent a branched or linear monovalent hydrocarbon group. The monovalent organic group may be a branched or linear monovalent hydrocarbon group such as an alkyl group of 4 to 15 carbon atoms, alternatively 9 to 12 carbon atoms. Suitable plasticizers may be selected from the group consisting of adipates, carboxylates, phthalates, and a combination thereof.

**[0096]** Alternatively, the organic plasticizer may have an average, per molecule, of at least two groups of the formula above bonded to carbon atoms in a cyclic hydrocarbon. The organic plasticizer may have general formula:

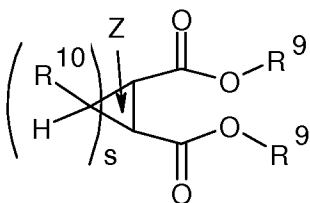

In this formula, group Z represents a cyclic hydrocarbon group having 3 or more carbon atoms, alternatively 3 to 15 carbon atoms. Subscript k may have a value ranging from 1 to 12. Group Z may be saturated or aromatic. Each R<sup>10</sup> is independently a hydrogen atom or a branched or linear monovalent organic group. The monovalent organic group for R<sup>9</sup> may be an alkyl group such as Me, Et, or Bu. Alternatively, the monovalent organic group for R<sup>10</sup> may be an ester functional group. Each R<sup>9</sup> is independently a branched or linear monovalent hydrocarbon group, such as an alkyl group of 4 to 15 carbon atoms.

**[0097]** Suitable organic plasticizers are known in the art and are commercially available. The plasticizer may comprise a phthalate, such as: a dialkyl phthalate such as dibutyl phthalate (Eastman™ DBP Plasticizer), diheptyl phthalate, di(2-ethylhexyl) phthalate, or diisodecyl phthalate (DIDP), bis(2-propylheptyl) phthalate (BASF Palatino® DPHP), di(2-ethylhexyl)

phthalate (Eastman™ DOP Plasticizer), dimethyl phthalate (Eastman™ DMP Plasticizer); diethyl phthalate (Eastman™ DMP Plasticizer); butyl benzyl phthalate, and bis(2-ethylhexyl) terephthalate (Eastman™ 425 Plasticizer); a dicarboxylate such as Benzyl, C7-C9 linear and branched alkyl esters, 1, 2, benzene dicarboxylic acid (Ferro SANTICIZER® 261A), 1,2,4-  
5 benzenetricarboxylic acid (BASF Palatinol® TOTM-I), bis(2-ethylhexyl)-1,4-benzenedicarboxylate (Eastman™ 168 Plasticizer); 2-ethylhexyl methyl-1,4-benzenedicarboxylate; 1,2 cyclohexanedicarboxylic acid, dinonyl ester, branched and linear (BASF Hexamoll \*DINCH); diisononyl adipate; trimellitates such as trioctyl trimellitate (Eastman™ TOTM Plasticizer); triethylene glycol bis(2-ethylhexanoate) (Eastman™ TEG-EH  
10 Plasticizer); triacetin (Eastman™ Triacetin); nonaromatic dibasic acid esters such as dioctyl adipate, bis(2-ethylhexyl) adipate (Eastman™ DOA Plasticizer and Eastman™ DOA Plasticizer, Kosher), di-2-ethylhexyladipate (BASF Plastomoll® DOA), dioctyl sebacate, dibutyl sebacate and diisodecyl succinate; aliphatic esters such as butyl oleate and methyl acetyl recinolate; phosphates such as tricresyl phosphate and tributyl phosphate; chlorinated paraffins;  
15 hydrocarbon oils such as alkylidiphenyls and partially hydrogenated terphenyls; process oils; epoxy plasticizers such as epoxidized soybean oil and benzyl epoxystearate; tris(2-ethylhexyl) ester; a fatty acid ester; and a combination thereof. Examples of other suitable plasticizers and their commercial sources include BASF Palamoll® 652 and Eastman 168 Xtreme™ Plasticizer.

**[0098]** Alternatively, a polymer plasticizer can be used. Examples of the polymer plasticizer  
20 include alkenyl polymers obtained by polymerizing vinyl or allyl monomers by means of various methods; polyalkylene glycol esters such as diethylene glycol dibenzoate, triethylene glycol dibenzoate and pentaerythritol ester; polyester plasticizers obtained from dibasic acids such as sebacic acid, adipic acid, azelaic acid and phthalic acid and dihydric alcohols such as ethylene glycol, diethylene glycol, triethylene glycol, propylene glycol and dipropylene glycol; polyethers  
25 including polyether polyols each having a molecular weight of not less than 500 such as polyethylene glycol, polypropylene glycol and polytetramethylene glycol, polystyrenes such as polystyrene and poly-alpha-methylstyrene; and polybutadiene, polybutene, polyisobutylene, butadiene acrylonitrile, and polychloroprene.

**[0099]** The polyorganosiloxane extenders and organic plasticizers described above for  
30 ingredient (E) may be used either each alone or in combinations of two or more thereof. A low molecular weight organic plasticizer and a higher molecular weight polymer plasticizer may be used in combination. The exact amount of ingredient (E) used in the composition will depend on various factors including the desired end use of the composition and the cured product thereof. However, the amount of ingredient (E) may range from 0.1 % to 10 % based on the  
35 combined weights of all ingredients in the composition.

**[0100]** Ingredient (F) is a filler. The filler may comprise a reinforcing filler, an extending filler, a conductive filler, or a combination thereof. For example, the composition may optionally further comprise ingredient (f1), a reinforcing filler, which when present may be added in an amount ranging from 0.1 % to 95 %, alternatively 1 % to 60 %, based on the weight of the composition. The exact amount of ingredient (f1) depends on various factors including the form of the reaction product of the composition (*e.g.*, gel or rubber) and whether any other fillers are added. Examples of suitable reinforcing fillers include chopped fiber such as chopped KEVLAR®, and/or reinforcing silica fillers such as fume silica, silica aerogel, silica xerogel, and precipitated silica. Fumed silicas are known in the art and commercially available; *e.g.*, fumed silica sold under the name CAB-O-SIL by Cabot Corporation of Massachusetts, U.S.A.

**[0101]** The composition may optionally further comprise ingredient (f2) an extending filler in an amount ranging from 0.1 % to 95 %, alternatively 1 % to 60 %, and alternatively 1 % to 20 %, based on the weight of the composition. Examples of extending fillers include crushed quartz, aluminum oxide, magnesium oxide, calcium carbonate such as precipitated calcium carbonate, zinc oxide, talc, diatomaceous earth, iron oxide, clays, mica, titanium dioxide, zirconia, sand, carbon black, graphite, or a combination thereof. Extending fillers are known in the art and commercially available; such as a ground silica sold under the name MIN-U-SIL by U.S. Silica of Berkeley Springs, WV. Suitable precipitated calcium carbonates included Winnofil® SPM from Solvay and Ultrapflex® and Ultrapflex® 100 from SMI.

**[0102]** The composition may optionally further comprise ingredient (f3) a conductive filler. Ingredient (F) may be both thermally conductive and electrically conductive. Alternatively, ingredient (F) may be thermally conductive and electrically insulating. Ingredient (F) may be selected from the group consisting of aluminum nitride, aluminum oxide, aluminum trihydrate, barium titanate, beryllium oxide, boron nitride, carbon fibers, diamond, graphite, magnesium hydroxide, magnesium oxide, metal particulate, onyx, silicon carbide, tungsten carbide, zinc oxide, and a combination thereof. Ingredient (F) may comprise a metallic filler, an inorganic filler, a meltable filler, or a combination thereof. Metallic fillers include particles of metals and particles of metals having layers on the surfaces of the particles. These layers may be, for example, metal nitride layers or metal oxide layers on the surfaces of the particles. Suitable metallic fillers are exemplified by particles of metals selected from the group consisting of aluminum, copper, gold, nickel, silver, and combinations thereof, and alternatively aluminum. Suitable metallic fillers are further exemplified by particles of the metals listed above having layers on their surfaces selected from the group consisting of aluminum nitride, aluminum oxide, copper oxide, nickel oxide, silver oxide, and combinations thereof. For example, the metallic filler may comprise aluminum particles having aluminum oxide layers on their surfaces.

**[0103]** Inorganic conductive fillers are exemplified by onyx; aluminum trihydrate, metal oxides such as aluminum oxide, beryllium oxide, magnesium oxide, and zinc oxide; nitrides such as aluminum nitride and boron nitride; carbides such as silicon carbide and tungsten carbide; and combinations thereof. Alternatively, inorganic conductive fillers are exemplified by aluminum  
5 oxide, zinc oxide, and combinations thereof. Meltable fillers may comprise Bi, Ga, In, Sn, or an alloy thereof. The meltable filler may optionally further comprise Ag, Au, Cd, Cu, Pb, Sb, Zn, or a combination thereof. Examples of suitable meltable fillers include Ga, In-Bi-Sn alloys, Sn-In-Zn alloys, Sn-In-Ag alloys, Sn-Ag-Bi alloys, Sn-Bi-Cu-Ag alloys, Sn-Ag-Cu-Sb alloys, Sn-Ag-Cu alloys, Sn-Ag alloys, Sn-Ag-Cu-Zn alloys, and combinations thereof. The meltable filler may  
10 have a melting point ranging from 50 °C to 250 °C, alternatively 150 °C to 225 °C. The meltable filler may be a eutectic alloy, a non-eutectic alloy, or a pure metal. Meltable fillers are commercially available.

**[0104]** For example, meltable fillers may be obtained from Indium Corporation of America, Utica, N.Y., U.S.A.; Arconium, Providence, R.I., U.S.A.; and AIM Solder, Cranston, R.I., U.S.A.  
15 Aluminum fillers are commercially available, for example, from Toyal America, Inc. of Naperville, Illinois, U.S.A. and Valimet Inc., of Stockton, California, U.S.A. Silver filler is commercially available from Metalor Technologies U.S.A. Corp. of Attleboro, Massachusetts, U.S.A.

**[0105]** Thermally conductive fillers are known in the art and commercially available. For  
20 example, CB-A20S and AI-43-Me are aluminum oxide fillers of differing particle sizes commercially available from Showa-Denko, and AA-04, AA-2, and AA18 are aluminum oxide fillers commercially available from Sumitomo Chemical Company. Zinc oxides, such as zinc oxides having trademarks KADOX® and XX®, are commercially available from Zinc Corporation of America of Monaca, Pennsylvania, U.S.A.

**[0106]** The shape of the filler particles is not specifically restricted, however, rounded or  
25 spherical particles may prevent viscosity increase to an undesirable level upon high loading of the filler in the composition.

**[0107]** Ingredient (F) may be a single filler or a combination of two or more fillers that differ in  
30 at least one property such as particle shape, average particle size, particle size distribution, and type of filler. For example, it may be desirable to use a combination of fillers, such as a first filler having a larger average particle size and a second filler having a smaller average particle size. Use of a first filler having a larger average particle size and a second filler having a smaller average particle size than the first filler may improve packing efficiency and/or may  
35 reduce viscosity of the composition as compared to a composition without such a combination of fillers.

[0108] The average particle size of the filler will depend on various factors including the type of the filler selected for ingredient (F) and the exact amount added to the composition, as well as the end use for the reaction product of the composition. However, the filler may have an average particle size ranging from 0.1 to 80  $\mu\text{m}$ , alternatively 0.1 to 50  $\mu\text{m}$ , and alternatively 0.1 to 10  $\mu\text{m}$ .

[0109] The amount of ingredient (F) in the composition depends on various factors including the end use selected for the composition and the reaction product of the composition, the type and amount of ingredient (B), and the type and amount of the filler selected for ingredient (F). However, the amount of ingredient (F) may range from 0 vol % to 80 vol %, alternatively 50 vol % to 75 vol %, and alternatively 30 % to 80 %, by volume of the composition. Without wishing to be bound by theory, it is thought that when the amount of filler is greater than 80 vol %, the composition may react to form a reaction product with insufficient dimensional integrity for some applications.

[0110] The composition may optionally further comprise ingredient (G) a treating agent. The amount of ingredient (G) will vary depending on factors such as the type of treating agent selected and the type and amount of particulates (such as ingredients (F) and/or (D)) to be treated, and whether the particulates are treated before being added to the composition, or whether the particulates are treated *in situ*. However, ingredient (G) may be used in an amount ranging from 0.01 % to 20 %, alternatively 0.1 % to 15 %, and alternatively 0.5 % to 5 %, based on the weight of all ingredients in the composition. Particulates, such as the filler, the physical drying agent, certain flame retardants, and/or certain pigments, when present, may optionally be surface treated with ingredient (G). Particulates may be treated with ingredient (G) before being added to the composition, or *in situ*. Ingredient (G) may comprise an alkoxysilane, an alkoxy-functional oligosiloxane, a cyclic polyorganosiloxane, a hydroxyl-functional oligosiloxane such as a dimethyl siloxane or methyl phenyl siloxane, or a fatty acid. Examples of fatty acids include stearates such as calcium stearate.

[0111] Some representative organosilicon filler treating agents that can be used as ingredient (G) include compositions normally used to treat silica fillers such as organochlorosilanes, organosiloxanes, organodisilazanes such as hexaalkyl disilazane, and organoalkoxysilanes such as  $\text{C}_6\text{H}_{13}\text{Si}(\text{OCH}_3)_3$ ,  $\text{C}_8\text{H}_{17}\text{Si}(\text{OC}_2\text{H}_5)_3$ ,  $\text{C}_{10}\text{H}_{21}\text{Si}(\text{OCH}_3)_3$ ,  $\text{C}_{12}\text{H}_{25}\text{Si}(\text{OCH}_3)_3$ ,  $\text{C}_{14}\text{H}_{29}\text{Si}(\text{OC}_2\text{H}_5)_3$ , and  $\text{C}_6\text{H}_5\text{CH}_2\text{CH}_2\text{Si}(\text{OCH}_3)_3$ . Other treating agents that can be used include alkylthiols, fatty acids, titanates, titanate coupling agents, zirconate coupling agents, and combinations thereof.

[0112] Alternatively, ingredient (G) may comprise an alkoxysilane having the formula:

$\text{R}^{11}_m\text{Si}(\text{OR}^{12})_{(4-m)}$ , where subscript  $m$  may have a value ranging from 1 to 3, alternatively

subscript m is 3. Each R<sup>11</sup> is independently a monovalent organic group, such as a monovalent hydrocarbon group of 1 to 50 carbon atoms, alternatively 8 to 30 carbon atoms, alternatively 8 to 18 carbon atoms. R<sup>11</sup> is exemplified by alkyl groups such as hexyl, octyl, dodecyl, tetradecyl, hexadecyl, and octadecyl; and aromatic groups such as benzyl and phenylethyl. R<sup>11</sup> may be saturated or unsaturated, and branched or unbranched.

Alternatively, R<sup>11</sup> may be saturated and unbranched.

**[0113]** Each R<sup>12</sup> is independently a saturated hydrocarbon group of 1 to 4 carbon atoms, alternatively 1 to 2 carbon atoms. Alkoxysilanes suitable for use as ingredient (G) are exemplified by hexyltrimethoxysilane, octyltriethoxysilane, decyltrimethoxysilane, dodecyltrimethoxysilane, tetradecyltrimethoxysilane, phenylethyltrimethoxysilane, octadecyltrimethoxysilane, octadecyltriethoxysilane, and combinations thereof.

**[0114]** Alkoxy-functional oligosiloxanes may also be used as treating agents. For example, suitable alkoxy-functional oligosiloxanes include those of the formula (V):

(R<sup>13</sup>O)<sub>n</sub>Si(OSiR<sup>14</sup><sub>2</sub>R<sup>15</sup>)<sub>(4-n)</sub>. In this formula, subscript n is 1, 2 or 3, alternatively subscript n

is 3. Each R<sup>13</sup> may be an alkyl group. Each R<sup>14</sup> may be an unsaturated monovalent hydrocarbon group of 1 to 10 carbon atoms. Each R<sup>15</sup> may be an unsaturated monovalent hydrocarbon group having at least 10 carbon atoms.

**[0115]** Certain particulates, such as metal fillers may be treated with alkylthiols such as octadecyl mercaptan; fatty acids such as oleic acid and stearic acid; and a combination thereof.

**[0116]** Treatment agents for alumina or passivated aluminum nitride may include alkoxysilyl functional alkylmethyl polysiloxanes (e.g., partial hydrolysis condensate of R<sup>16</sup><sub>o</sub>R<sup>17</sup><sub>p</sub>Si(OR<sup>18</sup>)<sub>(4-o-p)</sub> or cohydrolysis condensates or mixtures), or similar materials where the hydrolyzable group may comprise silazane, acyloxy or oximo. In all of these, a group tethered to Si, such as R<sup>16</sup> in the formula above, is a long chain unsaturated monovalent hydrocarbon or monovalent aromatic-functional hydrocarbon. Each R<sup>17</sup> is independently a monovalent hydrocarbon group, and each R<sup>18</sup> is independently a monovalent hydrocarbon group of 1 to 4 carbon atoms. In the formula above, subscript o is 1, 2, or 3 and subscript p is 0, 1, or 2, with the proviso that a sum (o + p) is 1, 2, or 3.

**[0117]** Other treating agents include alkenyl functional polyorganosiloxanes. Suitable alkenyl functional polyorganosiloxanes include, but are not limited to:

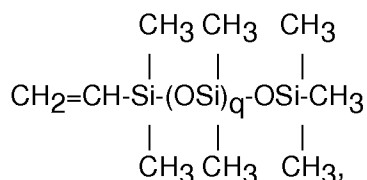

where subscript q has a value up to 1,500. Other treating agents include mono-encapped alkoxy functional polydiorganosiloxanes, *i.e.*, polydiorganosiloxanes having an alkoxy group at one end. Such treating agents are exemplified by the formula:

$R^{25}R^{26}_2SiO(R^{26}_2SiO)_uSi(OR^{27})_3$ , where subscript u has a value of 0 to 100, alternatively 1

5 to 50, alternatively 1 to 10, and alternatively 3 to 6. Each  $R^{25}$  is independently selected from an alkyl group, such as Me, Et, Pr, Bu, hexyl, and octyl; and an alkenyl group, such as Vi, allyl, butenyl, and Hex. Each  $R^{26}$  is independently an alkyl group such as Me, Et, Pr, Bu, hexyl, and octyl. Each  $R^{27}$  is independently an alkyl group such as Me, Et, Pr, and Bu. Alternatively, each  $R^{25}$ , each  $R^{26}$ , and each  $R^{27}$  is Me. Alternatively, each  $R^{25}$  is Vi. Alternatively, each  
10  $R^{26}$  and each  $R^{27}$  is Me.

**[0118]** Alternative, a polyorganosiloxane capable of hydrogen bonding is useful as a treating agent. This strategy to treating surface of a filler takes advantage of multiple hydrogen bonds, either clustered or dispersed or both, as the means to tether the compatibilization moiety to the filler surface. The polyorganosiloxane capable of hydrogen bonding has an average, per  
15 molecule, of at least one silicon-bonded group capable of hydrogen bonding. The group may be selected from: an organic group having multiple hydroxyl functionalities or an organic group having at least one amino functional group. The polyorganosiloxane capable of hydrogen bonding means that hydrogen bonding is the primary mode of attachment for the polyorganosiloxane to a filler. The polyorganosiloxane may be incapable of forming covalent  
20 bonds with the filler. The polyorganosiloxane capable of hydrogen bonding may be selected from the group consisting of a saccharide-siloxane polymer, an amino-functional polyorganosiloxane, and a combination thereof. Alternatively, the polyorganosiloxane capable of hydrogen bonding may be a saccharide-siloxane polymer.

**[0119]** Ingredient (H) is a biocide. The amount of ingredient (H) will vary depending on  
25 factors including the type of biocide selected and the benefit desired. However, the amount of ingredient (H) may range from greater than 0 % to 5 % based on the weight of all ingredients in the composition. Ingredient (H) is exemplified by (h1) a fungicide, (h2) an herbicide, (h3) a pesticide, (h4) an antimicrobial agent, or a combination thereof.

**[0120]** Ingredient (h1) is a fungicide, for example, these include N-substituted benzimidazole  
30 carbamate, benzimidazolyl carbamate such as methyl 2-benzimidazolylcarbamate, ethyl 2-benzimidazolylcarbamate, isopropyl 2-benzimidazolylcarbamate, methyl N-{2-[1-(N,N-dimethylcarbamoyl)benzimidazolyl]}carbamate, methyl N-{2-[1-(N,N-dimethylcarbamoyl)-6-methylbenzimidazolyl]}carbamate, methyl N-{2-[1-(N,N-dimethylcarbamoyl)-5-methylbenzimidazolyl]}carbamate, methyl N-{2-[1-(N-methylcarbamoyl)benzimidazolyl]}  
35 }carbamate, methyl N-{2-[1-(N-methylcarbamoyl)-6-methylbenzimidazolyl]}carbamate, methyl

N-{2-[1-(N-methylcarbamoyl)-5-methylbenzimidazolyl]}carbamate, ethyl N-{2-[1-(N,N-dimethylcarbamoyl)benzimidazolyl]}carbamate, ethyl N-{2-[2-(N-methylcarbamoyl)benzimidazolyl]}carbamate, ethyl N-{2-[1-(N,N-dimethylcarbamoyl)-6-methylbenzimidazolyl]}carbamate, ethyl N-{2-[1-(N-methylcarbamoyl)-6-methylbenzimidazolyl]}carbamate, isopropyl N-{2-[1-(N,N-dimethylcarbamoyl)benzimidazolyl]}carbamate, isopropyl N-{2-[1-(N-methylcarbamoyl)benzimidazolyl]}carbamate, methyl N-{2-[1-(N-propylcarbamoyl)benzimidazolyl]}carbamate, methyl N-{2-[1-(N-butylcarbamoyl)benzimidazolyl]}carbamate, methoxyethyl N-{2-[1-(N-propylcarbamoyl)benzimidazolyl]}carbamate, methoxyethyl N-{2-[1-(N-butylcarbamoyl)benzimidazolyl]}carbamate, ethoxyethyl N-{2-[1-(N-propylcarbamoyl)benzimidazolyl]}carbamate, ethoxyethyl N-{2-[1-(N-butylcarbamoyl)benzimidazolyl]}carbamate, methyl N-{1-(N,N-dimethylcarbamoyloxy)benzimidazolyl]}carbamate, methyl N-{2-[N-methylcarbamoyloxy)benzimidazolyl]}carbamate, methyl N-{2-[1-(N-butylcarbamoyloxy)benzimidazolyl]}carbamate, ethoxyethyl N-{2-[1-(N-propylcarbamoyl)benzimidazolyl]}carbamate, ethoxyethyl N-{2-[1-(N-butylcarbamoyloxy)benzimidazolyl]}carbamate, methyl N-{2-[1-(N,N-dimethylcarbamoyl)-6-chlorobenzimidazolyl]}carbamate, and methyl N-{2-[1-(N,N-dimethylcarbamoyl)-6-nitrobenzimidazolyl]}carbamate; 10, 10'-oxybisphenoxarsine (which has trade name Vinyzene, OBPA), di-iodomethyl-para-tolylsulfone, benzothiophene-2-cyclohexylcarboxamide-S,S-dioxide, N-(fluordichloridemethylthio)phthalimide (which has trade names Fluor-Folper, and Preventol A3); methyl-benzimideazol-2-ylcarbamate (which has trade names Carbendazim, and Preventol BCM), zinc-bis(2-pyridylthio-1-oxide) (zinc pyrithion) 2-(4-thiazolyl)-benzimidazol, N-phenyl-iodpropargylcarbamate, N-octyl-4-isothiazolin-3-on, 4,5-dichloride-2-n-octyl-4-isothiazolin-3-on, N-butyl-1,2-benzisothiazolin-3-on and/or triazolyl-compounds, such as tebuconazol in combination with zeolites containing silver.

**[0121]** Ingredient (h2) is an herbicide, for example, suitable herbicides include amide herbicides such as allidochlor *N,N*-diallyl-2-chloroacetamide; CDEA 2-chloro-*N,N*-diethylacetamide; etnipromid (*RS*)-2-[5-(2,4-dichlorophenoxy)-2-nitrophenoxy]-*N*-ethylpropionamide; anilide herbicides such as cisanilide *cis*-2,5-dimethylpyrrolidine-1-carboxanilide; flufenacet 4'-fluoro-*N*-isopropyl-2-[5-(trifluoromethyl)-1,3,4-thiadiazol-2-yloxy]acetanilide; naproanilide (*RS*)- $\alpha$ -2-naphthoxypropionanilide; arylalanine herbicides such as benzoylprop *N*-benzoyl-*N*-(3,4-dichlorophenyl)-DL-alanine; flamprop-M *N*-benzoyl-*N*-(3-chloro-4-fluorophenyl)-D-alanine; chloroacetanilide herbicides such as butachlor *N*-butoxymethyl-2-chloro-2',6'-diethylacetanilide; metazachlor 2-chloro-*N*-(pyrazol-1-ylmethyl)acet-

2',6'-xylylidide; prynachlor (*RS*)-2-chloro-*N*-(1-methylprop-2-ynyl)acetanilide; sulphonanilide herbicides such as cloransulam 3-chloro-2-(5-ethoxy-7-fluoro[1,2,4]triazolo[1,5-*c*]pyrimidin-2-ylsulphonamido)benzoic acid; metosulam 2',6'-dichloro-5,7-dimethoxy-3'-methyl[1,2,4]triazolo[1,5-*a*]pyrimidine-2-sulphonanilide; antibiotic herbicides such as bilanafos 5 4-[hydroxy(methyl)phosphinoyl]-*L*-homoalanyl-*L*-alanyl-*L*-alanine; benzoic acid herbicides such as chloramben 3-amino-2,5-dichlorobenzoic acid; 2,3,6-TBA 2,3,6-trichlorobenzoic acid; pyrimidinyloxybenzoic acid herbicides such as bispyribac 2,6-bis(4,6-dimethoxypyrimidin-2-ylloxy)benzoic acid; pyrimidinylthiobenzoic acid herbicides such as pyriothiobac 2-chloro-6-(4,6-dimethoxypyrimidin-2-ylthio)benzoic acid; phthalic acid herbicides such as chlorthal 10 tetrachloroterephthalic acid; picolinic acid herbicides such as aminopyralid 4-amino-3,6-dichloropyridine-2-carboxylic acid; quinolinecarboxylic acid herbicides such as quinclorac 3,7-dichloroquinoline-8-carboxylic acid; arsenical herbicides such as CMA calcium bis(hydrogen methylarsonate); MAMA ammonium hydrogen methylarsonate; sodium arsenite; benzoylcyclohexanedione herbicides such as mesotrione 2-(4-mesy-2-15 nitrobenzoyl)cyclohexane-1,3-dione; benzofuranyl alkylsulphonate herbicides such as benfuresate 2,3-dihydro-3,3-dimethylbenzofuran-5-yl ethanesulphonate; carbamate herbicides such as carboxazole methyl 5-*tert*-butyl-1,2-oxazol-3-ylcarbamate; fenasulam methyl 4-[2-(4-chloro-*o*-tolylloxy)acetamido]phenylsulphonylcarbamate; carbanilate herbicides such as BCPC (*RS*)-*sec*-butyl 3-chlorocarbanilate; desmedipham ethyl 3-20 phenylcarbamoyloxyphenylcarbamate; swep methyl 3,4-dichlorocarbanilate; cyclohexene oxime herbicides such as butoxydim (*RS*)-(*EZ*)-5-(3-butyryl-2,4,6-trimethylphenyl)-2-(1-ethoxyiminopropyl)-3-hydroxycyclohex-2-en-1-one; tepraloxym (*RS*)-(*EZ*)-2-{1-[(2*E*)-3-chloroallyloxymino]propyl}-3-hydroxy-5-perhydropyran-4-ylcyclohex-2-en-1-one; cyclopropylisoxazole herbicides such as isoxachlortole 4-chloro-2-mesyphenyl 5-cyclopropyl-25 1,2-oxazol-4-yl ketone; dicarboximide herbicides such as flumezin 2-methyl-4-( $\alpha,\alpha,\alpha$ -trifluoro-*m*-tolyl)-1,2,4-oxadiazinane-3,5-dione; dinitroaniline herbicides such as ethalfuralin *N*-ethyl- $\alpha,\alpha,\alpha$ -trifluoro-*N*-(2-methylallyl)-2,6-dinitro-*p*-toluidine; prodiamine 5-dipropylamino- $\alpha,\alpha,\alpha$ -trifluoro-4,6-dinitro-*o*-toluidine; dinitrophenol herbicides such as dinoprop 4,6-dinitro-*o*-cymen-3-ol; etinofen  $\alpha$ -ethoxy-4,6-dinitro-*o*-cresol; diphenyl ether herbicides such as ethoxyfen *O*-[2-chloro-5-(2-30 chloro- $\alpha,\alpha,\alpha$ -trifluoro-*p*-tolylloxy)benzoyl]-*L*-lactic acid; nitrophenyl ether herbicides such as aclonifen 2-chloro-6-nitro-3-phenoxyaniline; nitrofen 2,4-dichlorophenyl 4-nitrophenyl ether; dithiocarbamate herbicides such as dazomet 3,5-dimethyl-1,3,5-thiadiazinane-2-thione; halogenated aliphatic herbicides such as dalapon 2,2-dichloropropionic acid; chloroacetic acid; imidazolinone herbicides such as imazapyr (*RS*)-2-(4-isopropyl-4-methyl-5-oxo-2-imidazolin-2-35 yl)nicotinic acid; inorganic herbicides such as disodium tetraborate decahydrate; sodium azide; nitrile herbicides such as chloroxynil 3,5-dichloro-4-hydroxybenzotrile; ioxynil 4-hydroxy-3,5-

di-iodobenzonitrile; organophosphorus herbicides such as anilofos *S*-4-chloro-*N*-isopropylcarbaniloylmethyl *O,O*-dimethyl phosphorodithioate; glufosinate 4-[hydroxy(methyl)phosphinoyl]-DL-homoalanine; phenoxy herbicides such as clomeprop (*RS*)-2-(2,4-dichloro-*m*-tolylloxy)propionanilide; fenteracol 2-(2,4,5-trichlorophenoxy)ethanol;

5 phenoxyacetic herbicides such as MCPA (4-chloro-2-methylphenoxy)acetic acid; phenoxybutyric herbicides such as MCPB 4-(4-chloro-*o*-tolylloxy)butyric acid; phenoxypropionic herbicides such as fenoprop (*RS*)-2-(2,4,5-trichlorophenoxy)propionic acid; aryloxyphenoxypropionic herbicides such as isoxapyrifop (*RS*)-2-[2-[4-(3,5-dichloro-2-pyridyloxy)phenoxy]propionyl]isoxazolidine; phenylenediamine herbicides such as dinitramine

10 *N*<sup>1</sup>,*N*<sup>1</sup>-diethyl-2,6-dinitro-4-trifluoromethyl-*m*-phenylenediamine, pyrazolyloxyacetophenone herbicides such as pyrazoxyfen 2-[4-(2,4-dichlorobenzoyl)-1,3-dimethylpyrazol-5-yloxy]acetophenone; pyrazolylphenyl herbicides such as pyraflufen 2-chloro-5-(4-chloro-5-difluoromethoxy-1-methylpyrazol-3-yl)-4-fluorophenoxyacetic acid; pyridazine herbicides such as pyridafol 6-chloro-3-phenylpyridazin-4-ol; pyridazinone herbicides such as chloridazon 5-amino-4-chloro-2-phenylpyridazin-3(2*H*)-one; oxapyrazon 5-bromo-1,6-dihydro-6-oxo-1-

15 phenylpyridazin-4-yloxamic acid; pyridine herbicides such as fluroxypyr 4-amino-3,5-dichloro-6-fluoro-2-pyridyloxyacetic acid; thiazopyr methyl 2-difluoromethyl-5-(4,5-dihydro-1,3-thiazol-2-yl)-4-isobutyl-6-trifluoromethylnicotinate; pyrimidinediamine herbicides such as iprymidam 6-chloro-*N*<sup>4</sup>-isopropylpyrimidine-2,4-diamine; quaternary ammonium herbicides such as

20 diethamquat 1,1'-bis(diethylcarbamoylmethyl)-4,4'-bipyridinium; paraquat 1,1'-dimethyl-4,4'-bipyridinium; thiocarbamate herbicides such as cycloate *S*-ethyl cyclohexyl(ethyl)thiocarbamate; tiocarbazil *S*-benzyl di-*sec*-butylthiocarbamate; thiocarbonate herbicides such as EXD *O,O*-diethyl dithiobis(thioformate); thiourea herbicides such as methiuron 1,1-dimethyl-3-*m*-tolyl-2-thiourea; triazine herbicides such as triaziflam (*RS*)-*N*-[2-

25 (3,5-dimethylphenoxy)-1-methylethyl]-6-(1-fluoro-1-methylethyl)-1,3,5-triazine-2,4-diamine; chlorotriazine herbicides such as cyprazine 6-chloro-*N*<sup>2</sup>-cyclopropyl-*N*<sup>4</sup>-isopropyl-1,3,5-triazine-2,4-diamine; propazine 6-chloro-*N*<sup>2</sup>,*N*<sup>4</sup>-di-isopropyl-1,3,5-triazine-2,4-diamine; methoxytriazine herbicides such as prometon *N*<sup>2</sup>,*N*<sup>4</sup>-di-isopropyl-6-methoxy-1,3,5-triazine-2,4-diamine; methylthiotriazine herbicides such as cyanatryn 2-(4-ethylamino-6-methylthio-1,3,5-triazin-2-ylamino)-2-methylpropionitrile; triazinone herbicides such as hexazinone 3-cyclohexyl-6-dimethylamino-1-methyl-1,3,5-triazine-2,4(1*H*,3*H*)-dione; triazole herbicides such as epronaz *N*-ethyl-*N*-propyl-3-propylsulphonyl-1*H*-1,2,4-triazole-1-carboxamide; triazolone herbicides such as

30 carfentrazone (*RS*)-2-chloro-3-[2-chloro-5-[4-(difluoromethyl)-4,5-dihydro-3-methyl-5-oxo-1*H*-1,2,4-triazol-1-yl]-4-fluorophenyl]propionic acid; triazolopyrimidine herbicides such as

35 florasulam 2',6',8-trifluoro-5-methoxy[1,2,4]triazolo[1,5-*c*]pyrimidine-2-sulphonanilide; uracil

herbicides such as fluproacil isopropyl 2-chloro-5-(1,2,3,6-tetrahydro-3-methyl-2,6-dioxo-4-trifluoromethylpyrimidin-1-yl)benzoate; urea herbicides such as cycluron 3-cyclo-octyl-1,1-dimethylurea; monisouron 1-(5-*tert*-butyl-1,2-oxazol-3-yl)-3-methylurea; phenylurea herbicides such as chloroxuron 3-[4-(4-chlorophenoxy)phenyl]-1,1-dimethylurea; siduron 1-(2-methylcyclohexyl)-3-phenylurea; pyrimidinylsulphonylurea herbicides such as flazasulphuron 1-(4,6-dimethoxypyrimidin-2-yl)-3-(3-trifluoromethyl-2-pyridylsulphonyl)urea; pyrazosulphuron 5-[(4,6-dimethoxypyrimidin-2-ylcarbamoyl)sulphamoyl]-1-methylpyrazole-4-carboxylic acid; triazinylsulphonylurea herbicides such as thifensulphuron 3-(4-methoxy-6-methyl-1,3,5-triazin-2-ylcarbamoylsulphamoyl)thiophene-2-carboxylic acid; thiadiazolylurea herbicides such as tebuthiuron 1-(5-*tert*-butyl-1,3,4-thiadiazol-2-yl)-1,3-dimethylurea; and/or unclassified herbicides such as chlorfenac (2,3,6-trichlorophenyl)acetic acid; methazole 2-(3,4-dichlorophenyl)-4-methyl-1,2,4-oxadiazolidine-3,5-dione; tritac (*RS*)-1-(2,3,6-trichlorobenzyloxy)propan-2-ol; 2,4-D, chlorimuron, and fenoxaprop; and combinations thereof.

**[0122]** Ingredient (h3) is a pesticide. Suitable pesticides are exemplified by atrazine, diazinon, and chlorpyrifos. For purposes of this application, pesticide includes insect repellents such as N,N-diethyl-meta-toluamide and pyrethroids such as pyrethrin.

**[0123]** Ingredient (h4) is an antimicrobial agent. Suitable antimicrobials are commercially available, such as DOW CORNING® 5700 and DOW CORNING® 5772, which are from Dow Corning Corporation of Midland, Michigan, U.S.A.

**[0124]** Alternatively, ingredient (H) may comprise a boron containing material, e.g., boric anhydride, borax, or disodium octaborate tetrahydrate; which may function as a pesticide, fungicide, and/or flame retardant.

**[0125]** Ingredient (I) is a stabilizer that may be used for altering the reaction rate of the composition, as compared to a composition containing the same ingredients but with the stabilizer omitted. Stabilizers for hydrosilylation curable compositions are exemplified by acetylenic alcohols such as methyl butynol, ethynyl cyclohexanol, dimethyl hexynol, and 3,5-dimethyl-1-hexyn-3-ol, 1-butyn-3-ol, 1-propyn-3-ol, 2-methyl-3-butyn-2-ol, 3-methyl-1-butyn-3-ol, 3-methyl-1-pentyn-3-ol, 3-phenyl-1-butyn-3-ol, 4-ethyl-1-octyn-3-ol, 3,5-dimethyl-1-hexyn-3-ol, and 1-ethynyl-1-cyclohexanol, and a combination thereof; cycloalkenylsiloxanes such as methylvinylcyclosiloxanes exemplified by 1,3,5,7-tetramethyl-1,3,5,7-tetravinylcyclotetrasiloxane, 1,3,5,7-tetramethyl-1,3,5,7-tetrahexenylcyclotetrasiloxane, and a combination thereof; ene-yne compounds such as 3-methyl-3-penten-1-yne, 3,5-dimethyl-3-hexen-1-yne; triazoles such as benzotriazole; phosphines; mercaptans; hydrazines; amines, such as tetramethyl ethylenediamine, dialkyl fumarates, dialkenyl fumarates, dialkoxyalkyl fumarates, maleates such as diallyl maleate; nitriles; ethers; carbon monoxide; alkenes such as

cyclo-octadiene, divinyltetramethyldisiloxane; alcohols such as benzyl alcohol; and a combination thereof.

**[0126]** Alternatively, ingredient (I) in the composition may be a silylated acetylenic compound. Without wishing to be bound by theory, it is thought that adding a silylated acetylenic compound  
5 reduces yellowing of the reaction product prepared from hydrosilylation reaction of the composition as compared to a reaction product from hydrosilylation of a composition that does not contain a silylated acetylenic compound or that contains an organic acetylenic alcohol stabilizer, such as those described above.

**[0127]** The silylated acetylenic compound is exemplified by (3-methyl-1-butyn-3-  
10 oxy)trimethylsilane, ((1,1-dimethyl-2-propynyl)oxy)trimethylsilane, bis(3-methyl-1-butyn-3-oxy)dimethylsilane, bis(3-methyl-1-butyn-3-oxy)silanemethylvinylsilane, bis((1,1-dimethyl-2-propynyl)oxy)dimethylsilane, methyl(tris(1,1-dimethyl-2-propynyloxy))silane, methyl(tris(3-methyl-1-butyn-3-oxy))silane, (3-methyl-1-butyn-3-oxy)dimethylphenylsilane, (3-methyl-1-butyn-3-oxy)dimethylhexenylsilane, (3-methyl-1-butyn-3-oxy)triethylsilane, bis(3-methyl-1-butyn-3-  
15 oxy)methyltrifluoropropylsilane, (3,5-dimethyl-1-hexyn-3-oxy)trimethylsilane, (3-phenyl-1-butyn-3-oxy)diphenylmethylsilane, (3-phenyl-1-butyn-3-oxy)dimethylphenylsilane, (3-phenyl-1-butyn-3-oxy)dimethylvinylsilane, (3-phenyl-1-butyn-3-oxy)dimethylhexenylsilane, (cyclohexyl-1-ethyn-1-oxy)dimethylhexenylsilane, (cyclohexyl-1-ethyn-1-oxy)dimethylvinylsilane, (cyclohexyl-1-ethyn-1-oxy)diphenylmethylsilane, (cyclohexyl-1-ethyn-1-oxy)trimethylsilane, and combinations  
20 thereof. Alternatively, ingredient (I) is exemplified by methyl(tris(1,1-dimethyl-2-propynyloxy))silane, ((1,1-dimethyl-2-propynyl)oxy)trimethylsilane, or a combination thereof. The silylated acetylenic compound useful as ingredient (I) may be prepared by methods known in the art, such as silylating an acetylenic alcohol described above by reacting it with a chlorosilane in the presence of an acid receptor.

**[0128]** The amount of stabilizer added to the composition will depend on various factors including the desired pot life of the composition, whether the composition will be a one part composition or a multiple part composition, the particular stabilizer used, and the selection and amount of ingredient (C), if present. However, when present, the amount of stabilizer may range from 0 % to 1 %, alternatively 0% to 5%, alternatively 0.001 % to 1 %, alternatively 0.01  
30 % to 0.5 %, and alternatively 0.0025 % to 0.025 %, based on the weight of all ingredients in the composition.

**[0129]** Ingredient (J) is a flame retardant. Suitable flame retardants may include, for example, carbon black, hydrated aluminum hydroxide, and silicates such as wollastonite, platinum and platinum compounds. Alternatively, the flame retardant may be selected from  
35 halogen based flame-retardants such as decabromodiphenyloxide, octabromodiphenyl oxide, hexabromocyclododecane, decabromobiphenyl oxide, diphenyloxybenzene, ethylene bis-

tetrabromophthalamide, pentabromoethyl benzene, pentabromobenzyl acrylate, tribromophenyl maleic imide, tetrabromobisphenyl A, bis-(tribromophenoxy) ethane, bis-(pentabromophenoxy) ethane, polydibromophenylene oxide, tribromophenylallyl ether, bis-dibromopropyl ether, tetrabromophthalic anhydride, dibromoneopentyl glycol, dibromoethyl dibromocyclohexane, pentabromodiphenyl oxide, tribromostyrene, pentabromochlorocyclohexane, tetrabromoxylene, hexabromocyclododecane, brominated polystyrene, tetradecabromodiphenoxybenzene, trifluoropropene and PVC. Alternatively, the flame retardant may be selected from phosphorus based flame-retardants such as (2,3-dibromopropyl)-phosphate, phosphorus, cyclic phosphates, triaryl phosphate, bis-melaminium pentate, pentaerythritol bicyclic phosphate, dimethyl methyl phosphate, phosphine oxide diol, triphenyl phosphate, tris- (2-chloroethyl) phosphate, phosphate esters such as tricreyl, trixylenyl, isodecyl diphenyl, ethylhexyl diphenyl, phosphate salts of various amines such as ammonium phosphate, trioctyl, tributyl or tris-butoxyethyl phosphate ester. Other flame retardants may include tetraalkyl lead compounds such as tetraethyl lead, iron pentacarbonyl, manganese methyl cyclopentadienyl tricarbonyl, melamine and derivatives such as melamine salts, guanidine, dicyandiamide, ammonium sulphamate, alumina trihydrate, and magnesium hydroxide alumina trihydrate.

**[0130]** The amount of flame retardant will vary depending on factors such as the flame retardant selected and whether solvent is present. However, the amount of flame retardant in the composition may range from greater than 0 % to 10 % based on the weight of all ingredients in the composition.

**[0131]** Ingredient (K) is a surface modifier. Suitable surface modifiers are exemplified by (k1) an adhesion promoter and (k2) a release agent. Suitable adhesion promoters for ingredient (k1) may comprise a transition metal chelate, a hydrocarbonoxysilane such as an alkoxysilane, a combination of an alkoxysilane and a hydroxy-functional polyorganosiloxane, an aminofunctional silane, or a combination thereof. Adhesion promoters are known in the art and may comprise silanes having the formula  $R^{19}_r R^{20}_s Si(OR^{21})_{4-(r+s)}$  where each  $R^{19}$  is independently a monovalent organic group having at least 3 carbon atoms;  $R^{20}$  contains at least one SiC bonded substituent having an adhesion-promoting group, such as amino, epoxy, mercapto or acrylate groups; subscript r has a value ranging from 0 to 2; subscript s is either 1 or 2; and the sum of (r + s) is not greater than 3. Alternatively, the adhesion promoter may comprise a partial condensate of the above silane. Alternatively, the adhesion promoter may comprise a combination of an alkoxysilane and a hydroxy-functional polyorganosiloxane.

**[0132]** Alternatively, the adhesion promoter may comprise an unsaturated or epoxy-functional compound. The adhesion promoter may comprise an unsaturated or epoxy-functional alkoxysilane. For example, the functional alkoxysilane can have the formula  $R^{22}_t Si(OR^{23})_{(4-t)}$ ,

where subscript t is 1, 2, or 3, alternatively subscript t is 1. Each R<sup>22</sup> is independently a monovalent organic group with the proviso that at least one R<sup>22</sup> is an unsaturated organic group or an epoxy-functional organic group. Epoxy-functional organic groups for R<sup>22</sup> are exemplified by 3-glycidoxypropyl and (epoxycyclohexyl)ethyl. Unsaturated organic groups for R<sup>22</sup> are exemplified by 3-methacryloyloxypropyl, 3-acryloyloxypropyl, and unsaturated monovalent hydrocarbon groups such as vinyl, allyl, hexenyl, undecylenyl. Each R<sup>23</sup> is independently a saturated hydrocarbon group of 1 to 4 carbon atoms, alternatively 1 to 2 carbon atoms. R<sup>23</sup> is exemplified by Me, Et, Pr, and Bu.

**[0133]** Examples of suitable epoxy-functional alkoxy silanes include 3-

glycidoxypropyltrimethoxysilane, 3-glycidoxypropyltriethoxysilane, (epoxycyclohexyl)ethyldimethoxysilane, (epoxycyclohexyl)ethyldiethoxysilane and combinations thereof. Examples of suitable unsaturated alkoxy silanes include vinyltrimethoxysilane, allyltrimethoxysilane, allyltriethoxysilane, hexenyltrimethoxysilane, undecylenyltrimethoxysilane, 3-methacryloyloxypropyl trimethoxysilane, 3-methacryloyloxypropyl triethoxysilane, 3-acryloyloxypropyl trimethoxysilane, 3-acryloyloxypropyl triethoxysilane, and combinations thereof.

**[0134]** Alternatively, the adhesion promoter may comprise an epoxy-functional siloxane such as a reaction product of a hydroxy-terminated polyorganosiloxane with an epoxy-functional alkoxy silane, as described above, or a physical blend of the hydroxy-terminated

polyorganosiloxane with the epoxy-functional alkoxy silane. The adhesion promoter may comprise a combination of an epoxy-functional alkoxy silane and an epoxy-functional siloxane.

For example, the adhesion promoter is exemplified by a mixture of 3-glycidoxypropyltrimethoxysilane and a reaction product of hydroxy-terminated

methylvinylsiloxane with 3-glycidoxypropyltrimethoxysilane, or a mixture of 3-

glycidoxypropyltrimethoxysilane and a hydroxy-terminated methylvinylsiloxane, or a mixture of 3-glycidoxypropyltrimethoxysilane and a hydroxy-terminated methylvinyl/dimethylsiloxane copolymer.

**[0135]** Alternatively, the adhesion promoter may comprise an aminofunctional silane, such as an aminofunctional alkoxy silane exemplified by H<sub>2</sub>N(CH<sub>2</sub>)<sub>2</sub>Si(OCH<sub>3</sub>)<sub>3</sub>,

H<sub>2</sub>N(CH<sub>2</sub>)<sub>2</sub>Si(OCH<sub>2</sub>CH<sub>3</sub>)<sub>3</sub>, H<sub>2</sub>N(CH<sub>2</sub>)<sub>3</sub>Si(OCH<sub>3</sub>)<sub>3</sub>, H<sub>2</sub>N(CH<sub>2</sub>)<sub>3</sub>Si(OCH<sub>2</sub>CH<sub>3</sub>)<sub>3</sub>,

CH<sub>3</sub>NH(CH<sub>2</sub>)<sub>3</sub>Si(OCH<sub>3</sub>)<sub>3</sub>, CH<sub>3</sub>NH(CH<sub>2</sub>)<sub>3</sub>Si(OCH<sub>2</sub>CH<sub>3</sub>)<sub>3</sub>, CH<sub>3</sub>NH(CH<sub>2</sub>)<sub>5</sub>Si(OCH<sub>3</sub>)<sub>3</sub>,

CH<sub>3</sub>NH(CH<sub>2</sub>)<sub>5</sub>Si(OCH<sub>2</sub>CH<sub>3</sub>)<sub>3</sub>, H<sub>2</sub>N(CH<sub>2</sub>)<sub>2</sub>NH(CH<sub>2</sub>)<sub>3</sub>Si(OCH<sub>3</sub>)<sub>3</sub>,

H<sub>2</sub>N(CH<sub>2</sub>)<sub>2</sub>NH(CH<sub>2</sub>)<sub>3</sub>Si(OCH<sub>2</sub>CH<sub>3</sub>)<sub>3</sub>, CH<sub>3</sub>NH(CH<sub>2</sub>)<sub>2</sub>NH(CH<sub>2</sub>)<sub>3</sub>Si(OCH<sub>3</sub>)<sub>3</sub>,

CH<sub>3</sub>NH(CH<sub>2</sub>)<sub>2</sub>NH(CH<sub>2</sub>)<sub>3</sub>Si(OCH<sub>2</sub>CH<sub>3</sub>)<sub>3</sub>, C<sub>4</sub>H<sub>9</sub>NH(CH<sub>2</sub>)<sub>2</sub>NH(CH<sub>2</sub>)<sub>3</sub>Si(OCH<sub>3</sub>)<sub>3</sub>,

C<sub>4</sub>H<sub>9</sub>NH(CH<sub>2</sub>)<sub>2</sub>NH(CH<sub>2</sub>)<sub>3</sub>Si(OCH<sub>2</sub>CH<sub>3</sub>)<sub>3</sub>, H<sub>2</sub>N(CH<sub>2</sub>)<sub>2</sub>SiCH<sub>3</sub>(OCH<sub>3</sub>)<sub>2</sub>,  
 H<sub>2</sub>N(CH<sub>2</sub>)<sub>2</sub>SiCH<sub>3</sub>(OCH<sub>2</sub>CH<sub>3</sub>)<sub>2</sub>, H<sub>2</sub>N(CH<sub>2</sub>)<sub>3</sub>SiCH<sub>3</sub>(OCH<sub>3</sub>)<sub>2</sub>, H<sub>2</sub>N(CH<sub>2</sub>)<sub>3</sub>SiCH<sub>3</sub>(OCH<sub>2</sub>CH<sub>3</sub>)<sub>2</sub>,  
 CH<sub>3</sub>NH(CH<sub>2</sub>)<sub>3</sub>SiCH<sub>3</sub>(OCH<sub>3</sub>)<sub>2</sub>, CH<sub>3</sub>NH(CH<sub>2</sub>)<sub>3</sub>SiCH<sub>3</sub>(OCH<sub>2</sub>CH<sub>3</sub>)<sub>2</sub>,  
 CH<sub>3</sub>NH(CH<sub>2</sub>)<sub>5</sub>SiCH<sub>3</sub>(OCH<sub>3</sub>)<sub>2</sub>, CH<sub>3</sub>NH(CH<sub>2</sub>)<sub>5</sub>SiCH<sub>3</sub>(OCH<sub>2</sub>CH<sub>3</sub>)<sub>2</sub>,  
 5 H<sub>2</sub>N(CH<sub>2</sub>)<sub>2</sub>NH(CH<sub>2</sub>)<sub>3</sub>SiCH<sub>3</sub>(OCH<sub>3</sub>)<sub>2</sub>, H<sub>2</sub>N(CH<sub>2</sub>)<sub>2</sub>NH(CH<sub>2</sub>)<sub>3</sub>SiCH<sub>3</sub>(OCH<sub>2</sub>CH<sub>3</sub>)<sub>2</sub>,  
 CH<sub>3</sub>NH(CH<sub>2</sub>)<sub>2</sub>NH(CH<sub>2</sub>)<sub>3</sub>SiCH<sub>3</sub>(OCH<sub>3</sub>)<sub>2</sub>, CH<sub>3</sub>NH(CH<sub>2</sub>)<sub>2</sub>NH(CH<sub>2</sub>)<sub>3</sub>SiCH<sub>3</sub>(OCH<sub>2</sub>CH<sub>3</sub>)<sub>2</sub>,  
 C<sub>4</sub>H<sub>9</sub>NH(CH<sub>2</sub>)<sub>2</sub>NH(CH<sub>2</sub>)<sub>3</sub>SiCH<sub>3</sub>(OCH<sub>3</sub>)<sub>2</sub>, C<sub>4</sub>H<sub>9</sub>NH(CH<sub>2</sub>)<sub>2</sub>NH(CH<sub>2</sub>)<sub>3</sub>SiCH<sub>3</sub>(OCH<sub>2</sub>CH<sub>3</sub>)<sub>2</sub>, and  
 a combination thereof.

**[0136]** Alternatively, the adhesion promoter may comprise a transition metal chelate.

10 Suitable transition metal chelates include titanates, zirconates such as zirconium acetylacetonate, aluminum chelates such as aluminum acetylacetonate, and combinations thereof. Alternatively, the adhesion promoter may comprise a combination of a transition metal chelate with an alkoxysilane, such as a combination of glycidoxypropyltrimethoxysilane with an aluminum chelate or a zirconium chelate.

15 **[0137]** Ingredient (k2) is a release agent. Suitable release agents are exemplified by fluorinated compounds, such as fluoro-functional silicones, or fluoro-functional organic compounds.

**[0138]** Alternatively, the surface modifier for ingredient (K) may be used to change the appearance of the surface of a reaction product of the composition. For example, surface  
 20 modifier may be used to increase gloss of the surface of a reaction product of the composition. Such a surface modifier may comprise a polydiorganosiloxane with alkyl and aryl groups. For example, DOW CORNING® 550 Fluid is a trimethylsiloxy-terminated poly(dimethyl/methylphenyl)siloxane with a viscosity of 125 cSt that is commercially available from Dow Corning Corporation of Midland, Michigan, U.S.A.

25 **[0139]** Alternatively, ingredient (K) may be a natural oil obtained from a plant or animal source, such as linseed oil, tung oil, soybean oil, castor oil, fish oil, hempseed oil, cottonseed oil, oiticica oil, or rapeseed oil.

**[0140]** The exact amount of ingredient (K) depends on various factors including the type of surface modifier selected as ingredient (K) and the end use of the composition and its reaction  
 30 product. However, ingredient (K), when present, may be added to the composition in an amount ranging from 0.01 to 50 weight parts based on the weight of the composition, alternatively 0.01 to 10 weight parts, and alternatively 0.01 to 5 weight parts. Ingredient (K) may be one adhesion promoter. Alternatively, ingredient (K) may comprise two or more different surface modifiers that differ in at least one of the following properties: structure,  
 35 viscosity, average molecular weight, polymer units, and sequence.

**[0141]** Chain lengtheners may include difunctional silanes and difunctional siloxanes, which extend the length of polyorganosiloxane chains before crosslinking occurs. Chain lengtheners may be used to reduce the modulus of elongation of the cured product. Chain lengtheners compete in their reactions with aliphatically unsaturated groups and/or silicon bonded hydrogen atoms in other ingredients of the composition, *e.g.*, ingredients (B) and/or ingredient (C), when present. Dimethylhydrogensiloxy-terminated polydimethylsiloxanes having relatively low degrees of polymerization (*e.g.*, DP ranging from 3 to 50) may be used as ingredient (L). Ingredient (L) may be one chain lengthener. Alternatively, ingredient (L) may comprise two or more different chain lengtheners that differ in at least one of the following properties: structure, viscosity, average molecular weight, polymer units, and sequence

**[0142]** Ingredient (M) is an endblocker comprising an M-unit, *i.e.*, a siloxane unit of formula  $R^{24}_3SiO_{1/2}$ , where each  $R^{24}$  independently represents a monovalent, non-functional, organic group, such as a monovalent hydrocarbon group free of aliphatic unsaturation. Ingredient (M) may comprise polyorganosiloxanes endblocked on one terminal end by a triorganosilyl group, *e.g.*,  $(CH_3)_3SiO-$ , and on the other end by a silicon bonded hydrogen atom and/or an aliphatically unsaturated organic group. Ingredient (M) may be a polydiorganosiloxane such as a polydimethylsiloxane. The polydiorganosiloxanes having both silicon bonded hydrogen terminals and triorganosilyl end groups, may have more than 50 %, alternatively more than 75 %, of the total end groups as silicon bonded hydrogen atoms. The amount of triorganosilyl group in the polydimethylsiloxane may be used to regulate the modulus of a cured product prepared by curing the composition. Without wishing to be bound by theory, it is thought that higher concentrations of triorganosilyl end groups may provide a lower modulus in cured products. Ingredient (M) may be one endblocker. Alternatively, ingredient (M) may comprise two or more different endblockers that differ in at least one of the following properties: structure, viscosity, average molecular weight, polymer units, and sequence.

**[0143]** Ingredient (N) is a flux agent. The composition may comprise 0 % to 2 % of the flux agent based on the weight of all ingredients in the composition. Molecules containing chemically active functional groups such as carboxylic acid and amines can be used as flux agents. Such flux agents can include aliphatic acids such as succinic acid, abietic acid, oleic acid, and adipic acid; aromatic acids such as benzoic acids; aliphatic amines and their derivatives, such as triethanolamine, hydrochloride salts of amines, and hydrobromide salts of amines. Flux agents are known in the art and are commercially available.

**[0144]** Ingredient (O) is an anti-aging additive. The anti-aging additive may comprise an antioxidant, a UV absorber, a UV stabilizer, a heat stabilizer, or a combination thereof. Suitable antioxidants are known in the art and are commercially available. Suitable antioxidants include phenolic antioxidants and combinations of phenolic antioxidants with stabilizers. Phenolic

antioxidants include fully sterically hindered phenols and partially hindered phenols; and sterically hindered amines such as tetramethyl-piperidine derivatives. Suitable phenolic antioxidants include vitamin E and IRGANOX® 1010 from Ciba Specialty Chemicals, U.S.A. IRGANOX® 1010 comprises pentaerythritol tetrakis(3-(3,5-di-t-butyl-4-

5 hydroxyphenyl)propionate). Examples of UV absorbers include phenol, 2-(2H-benzotriazol-2-yl)-6-dodecyl-4-methyl-, branched and linear (TINUVIN® 571). Examples of UV stabilizers include bis(1,2,2,6,6-pentamethyl-4-piperidyl) sebacate; methyl 1,2,2,6,6-pentamethyl-4-piperidyl/sebacate; and a combination thereof (TINUVIN® 272). These and other TINUVIN® additives, such as TINUVIN® 765 are commercially available from Ciba Specialty Chemicals of  
10 Tarrytown, NY, U.S.A. Other UV and light stabilizers are commercially available, and are exemplified by LowLite from Chemtura, OnCap from PolyOne, and Light Stabilizer 210 from E. I. du Pont de Nemours and Company of Delaware, U.S.A. Oligomeric (higher molecular weight) stabilizers may alternatively be used, for example, to minimize potential for migration of the stabilizer out of the composition or the cured product thereof. An example of an oligomeric  
15 antioxidant stabilizer (specifically, hindered amine light stabilizer (HALS)) is Ciba TINUVIN® 622, which is a dimethylester of butanedioic acid copolymerized with 4-hydroxy-2,2,6,6-tetramethyl-1-piperidine ethanol. Heat stabilizers may include iron oxides and carbon blacks, iron carboxylate salts, cerium hydrate, barium zirconate, cerium and zirconium octoates, and porphyrins.

20 **[0145]** The amount of ingredient (O) depends on various factors including the specific anti-aging additive selected and the anti-aging benefit desired. However, the amount of ingredient (O) may range from 0 to 5 weight %, alternatively 0.1 % to 4 %, and alternatively 0.5 to 3 weight %, based on the weight of all ingredients in the composition. Ingredient (O) may be one anti-aging additive. Alternatively, ingredient (O) may comprise two or more different anti-aging  
25 additives.

**[0146]** Ingredient (P) is a pigment. For purposes of this application, the term 'pigment' includes any ingredient used to impart color to a reaction product of a composition described herein. The amount of pigment depends on various factors including the type of pigment selected and the desired degree of coloration of the product. For example, the composition  
30 may comprise 0 to 20 %, alternatively 0.001 % to 5 %, of a pigment based on the weight of all ingredients in the composition.

**[0147]** Examples of suitable pigments include indigo, titanium dioxide Stan-Tone 50SP01 Green (which is commercially available from PolyOne) and carbon black. Representative, non-limiting examples of carbon black include Shawinigan Acetylene black, which is commercially  
35 available from Chevron Phillips Chemical Company LP; SUPERJET® Carbon Black (LB-1011) supplied by Elementis Pigments Inc., of Fairview Heights, IL U.S.A.; SR 511 supplied by Sid

Richardson Carbon Co, of Akron, OH U.S.A.; and N330, N550, N762, N990 (from Degussa Engineered Carbons of Parsippany, NJ, U.S.A.).

**[0148]** Ingredient (Q) is an acid acceptor. Suitable acid acceptors include magnesium oxide, calcium oxide, and combinations thereof. The composition may comprise 0 % to 2 % of

5 ingredient (Q) based on the weight of the composition.

**[0149]** The composition may optionally further comprise up to 5 %, alternatively 1 % to 2 % based on the weight of the composition of ingredient (R) a rheological additive for modifying rheology of the composition. Rheological additives are known in the art and are commercially available. Examples include polyamides, Polyvest, which is commercially available from

10 Evonk, Disparlon from King Industries, Kevlar Fibre Pulp from Du Pont, Rheospan from Nanocor, and Ircogel from Lubrizol. Other suitable rheological additives include polyamide waxes; hydrogenated castor oil derivatives; and metal soaps such as calcium stearate, aluminum stearate and barium stearate, and combinations thereof.

**[0150]** Alternatively, ingredient (R) may comprise a microcrystalline wax that is a solid at 25

15 °C (wax). The melting point may be selected such that the wax has a melting point at the low end of the desired application temperature range. Without wishing to be bound by theory, it is thought that ingredient (R) acts as a process aid that improves flow properties of the composition. Without wishing to be bound by theory, it is thought that incorporation of wax may also facilitate incorporation of fillers, compounding and de-airing (during production of the

20 composition), and mixing (static or dynamic mixing during application of parts of a multiple part composition). It is thought that the wax, when molten, serves as a process aid, substantially easing the incorporation of filler in the composition during compounding, the compounding process itself, as well as in during a de-airing step, if used. The wax, with a melt temperature below 100 °C, may facilitate mixing of the parts of a multiple part composition before

25 application, even in a simple static mixer.

**[0151]** Waxes suitable for use as ingredient (R) may be non-polar hydrocarbons. The waxes may have branched structures, cyclic structures, or combinations thereof. For example, petroleum microcrystalline waxes are available from Strahl & Pitsch, Inc., of West Babylon, NY, U.S.A. and include SP 96 (melting point ranging from 62 °C to 69 °C), SP 18 (melting point

30 ranging from 73 °C to 80 °C), SP 19 (melting point ranging from 76 °C to 83 °C), SP 26 (melting point ranging from 76 °C to 83 °C), SP 60 (melting point ranging from 79 °C to 85 °C), SP 617 (melting point ranging from 88 °C to 93 °C), SP 89 (melting point ranging from 90 °C to 95 °C), and SP 624 (melting point ranging from 90 °C to 95 °C). Other petroleum microcrystalline waxes include waxes marketed under the trademark Multiwax® by Crompton Corporation of

35 Petrolia, Pennsylvania, U.S.A. These waxes include 180-W, which comprises saturated branched and cyclic non-polar hydrocarbons and has melting point ranging from 79 °C to 87 °C;

Multiwax® W-445, which comprises saturated branched and cyclic non-polar hydrocarbons, and has melting point ranging from 76 °C to 83 °C; and Multiwax® W-835, which comprises saturated branched and cyclic non-polar hydrocarbons, and has melting point ranging from 73 °C to 80 °C.

5 **[0152]** The amount of ingredient (R) depends on various factors including the specific rheological additive selected and the selections of the other ingredients of the composition. However, the amount of ingredient (R) may range from 0 parts to 20 parts, alternatively 1 parts to 15 parts, and alternatively 1 part to 5 parts based on the weight of all ingredients in the composition. Ingredient (R) may be one rheological additive. Alternatively, ingredient (R) may  
10 comprise two or more different rheological additives.

**[0153]** A vehicle may be used in the composition. The vehicle may facilitate flow of the composition and introduction of certain ingredients, such as silicone resin. Vehicles used herein are those that help fluidize the ingredients of the composition but essentially do not react with the ingredients. The vehicle may be selected based on solubility the ingredients in the  
15 composition and volatility. The solubility refers to the vehicle being sufficient to dissolve and/or disperse ingredients of the composition. Volatility refers to vapor pressure of the vehicle. If the vehicle is too volatile (having too high vapor pressure) bubbles may form in the composition during hydrosilylation reaction, and the bubbles may cause cracks or otherwise weaken or detrimentally affect properties of the reaction product. However, if the vehicle is not volatile  
20 enough (too low vapor pressure) the vehicle may remain as a plasticizer in the reaction product of the composition.

**[0154]** Suitable vehicles include polyorganosiloxanes with suitable vapor pressures, such as hexamethyldisiloxane, octamethyltrisiloxane, hexamethylcyclotrisiloxane and other low molecular weight polyorganosiloxanes, such as 0.5 to 1.5 cSt Dow Corning® 200 Fluids and  
25 Dow Corning® OS FLUIDS, which are commercially available from Dow Corning Corporation of Midland, Michigan, U.S.A.

**[0155]** Alternatively, the vehicle may comprise an organic solvent. The organic solvent can be an alcohol such as methanol, ethanol, isopropanol, butanol, or n-propanol; a ketone such as acetone, methylethyl ketone, or methyl isobutyl ketone; an aromatic hydrocarbon such as  
30 benzene, toluene, or xylene; an aliphatic hydrocarbon such as heptane, hexane, or octane; a glycol ether such as propylene glycol methyl ether, dipropylene glycol methyl ether, propylene glycol n-butyl ether, propylene glycol n-propyl ether, or ethylene glycol n-butyl ether, a halogenated hydrocarbon such as dichloromethane, 1,1,1-trichloroethane or methylene chloride; chloroform; dimethyl sulfoxide; dimethyl formamide, acetonitrile; tetrahydrofuran; white  
35 spirits; mineral spirits; naphtha; n-methyl pyrrolidone; or a combination thereof.

**[0156]** The amount of vehicle will depend on various factors including the type of vehicle selected and the amount and type of other ingredients selected for the composition. However, the amount of vehicle may range from 1 % to 99%, alternatively 2 % to 50 %, based on the weight of all ingredients in the composition. Ingredient (S) can be added during preparation of the composition, for example, to aid mixing and delivery. All or a portion of ingredient (S) may optionally be removed after the composition is prepared.

**[0157]** Ingredient (T) is a surfactant. Suitable surfactants include silicone polyethers, ethylene oxide polymers, propylene oxide polymers, copolymers of ethylene oxide and propylene oxide, other non-ionic surfactants, and combinations thereof. The composition may comprise 0 % to 0.05 % of the surfactant based on the weight of all ingredients in the composition.

**[0158]** Ingredient (U) is a corrosion inhibitor. Examples of suitable corrosion inhibitors include benzotriazole, mercaptabenzotriazole and commercially available corrosion inhibitors such as 2,5-dimercapto-1,3,4-thiadiazole derivative (CUVAN® 826) and alkylthiadiazole (CUVAN® 484) from R. T. Vanderbilt of Norwalk, Connecticut, U.S.A. When present, the amount of ingredient (U) may range from 0.05 % to 0.5 % based on the weight of the composition.

**[0159]** When selecting ingredients for the composition described above, there may be overlap between types of ingredients because certain ingredients described herein may have more than one function. For example, certain alkoxysilanes may be useful as filler treating agents and as adhesion promoters, and certain plasticizers such as fatty acid esters may also be useful as filler treating agents. Certain particulates may be useful as fillers and as pigments, and even as flame retardants, *e.g.*, carbon black. When adding additional ingredients to the composition, the additional ingredients are distinct from one another.

**[0160]** The composition can be prepared by a method comprising combining all ingredients by any convenient means such as mixing at ambient or elevated temperature. Ingredient (I), when present, may be added before ingredient (A), for example, when the composition will be prepared at elevated temperature and/or the composition will be prepared as a one part composition.

**[0161]** When ingredient (G) is present, the composition may optionally be prepared by surface treating a particulate ingredient (*e.g.*, filler and/or spacer, if present) with ingredient (G), and thereafter mixing the product thereof with the other ingredients of the composition.

**[0162]** Alternatively, the composition may be prepared as a multiple part composition, for example, when ingredient (I) is absent, or when the composition will be stored for a long period of time before use. In the multiple part composition, ingredient (A) is stored in a separate part from any ingredient having a silicon bonded hydrogen atom, for example ingredient (C), and the parts are combined shortly before use of the composition. For example, a two part composition

may be prepared by combining ingredients comprising (B), (A), (F), and optionally one or more other additional ingredients described above to form a base by any convenient means such as mixing. A curing agent may be prepared by combining ingredients comprising (B), (C), and optionally one or more other additional ingredients described above by any convenient means such as mixing. The ingredients may be combined at ambient or elevated temperature. When a two part composition is used, the weight ratio of amounts of base to curing agent may range from 1:1 to 10:1. The composition will react via hydrosilylation reaction to form a reaction product. The reaction product may have various forms, such as a silane, a gum, a gel, a rubber, or a resin.

### EXAMPLES

**[0163]** These examples are intended to illustrate some embodiments of the invention and should not be interpreted as limiting the scope of the invention set forth in the claims. The following ingredients were used in the examples.

**[0164]** The aliphatically unsaturated compound can be styrene (B1), 1-octene (B2), or 1-hexene (B3), all of which are also available from Sigma-Aldrich. Or, the aliphatically unsaturated compound can be (B4) a vinyl terminated polydimethylsiloxane, containing 2.6 meq silicon bonded vinyl groups and having Mw of 9400 and viscosity of 200 cSt, which is commercially available as DMS-V22 from Gelest, Inc. of Morrisville, Pennsylvania, U.S.A. The SiH functional compound can be (C1) a trimethylsiloxy-terminated,

poly(methylhydrogen)siloxane ("MDHM") having Mw ranging from 1,800 to 2,100 and SiH content of 2.6 meq, which is commercially available as HMS-992, also from Gelest, Inc. Alternatively, the SiH functional compound can be (C2) Phenylsilane ("H<sub>3</sub>SiPh"), which is commercially available from Sigma-Aldrich.

**[0165]** The control catalyst was DOW CORNING® 2-0707 INT, which is a complex of Pt with a polyorganosiloxane. DOW CORNING® 2-0707 INT is commercially available from Dow Corning Corporation of Midland, Michigan, U.S.A.

**[0166]** One or more of the following model reactions may be used to test catalytic activity of a reaction product prepared as described above for ingredient (A). Ingredients (B3) and (C2) were used in the [PhSi] reaction to attempt to make a reaction product [I] comprising PhSiH<sub>2</sub>(C<sub>6</sub>H<sub>13</sub>)<sub>(3-z)</sub>. Ingredients (B3) and (C1) were used in the [HMTS] reaction to attempt to make a reaction product [II] comprising (H<sub>3</sub>C)<sub>3</sub>Si-O-Si(CH<sub>2</sub>)(C<sub>6</sub>H<sub>13</sub>)-O-Si(CH<sub>3</sub>)<sub>3</sub>.

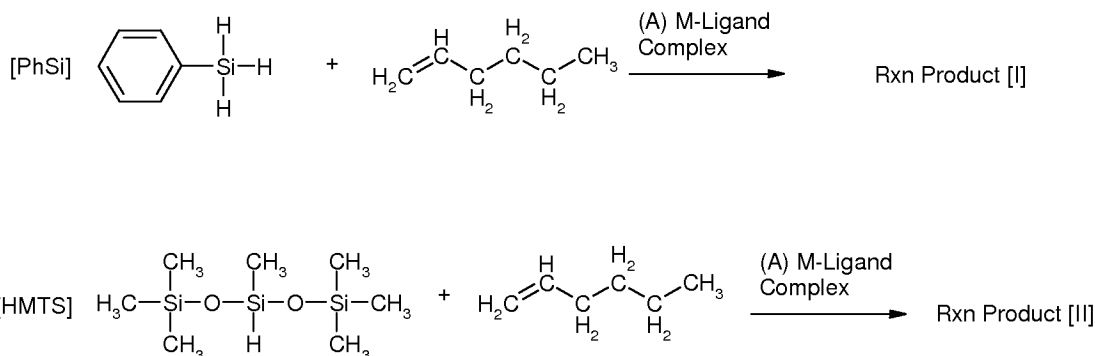

### Example 1 – Formation of Metal-Ligand complexes

**[0167]** Precursor solutions were prepared by mixing a Re precursor described above in Table 1 at a 0.025 molar (M) concentration with THF or, if the precursor was insoluble in THF, then a suitable solvent to dissolve the ligand selected from dimethylsulfoxide (DMSO), toluene, and hexane. Solutions of each ligand shown above in Table 2 and Table 3 were also prepared by mixing the ligand at a 0.025 M concentration with THF. Each ligand solution prepared above was dispensed into 2 milliliter (mL) vials at 85 microliters ( $\mu\text{L}$ ) per vial. To prepare samples to evaluate as ingredient (A), one of the metal precursor solutions described above was added to a vial containing a ligand, and an additional 85 microliters ( $\mu\text{L}$ ) THF was added, and the vial contents were mixed at 300 RPM at room temperature of 25 °C for 2 hours. A sufficient amount of metal precursor solution was added such that the Metal : Ligand Ratio was either 1 : 1 or 1 : 2. The resulting mixture in the vial was cooled to a temperature of -17 °C. An activator was added, and the vial was allowed to return to room temperature. The activator was 95  $\mu\text{L}$  at 0.05 M concentration of either LiBARF in THF or NaEt<sub>3</sub>BH in toluene. The vial contents were mixed for 2 hours. The resulting vial contents were evaluated for use in catalyzing hydrosilylation.

### Example 2 - [PhSi] Reaction

**[0168]** To perform the [PhSi] reaction, PhSiH<sub>3</sub> (C2) in dodecane and 1-hexene (B3) were added to a vial prepared according to Example 1. The amount of PhSiH<sub>3</sub> (C2) added to the vial was either 170  $\mu\text{L}$  of 6.25 M (as H or SiH) PhSiH<sub>3</sub> (C2) in dodecane, or 132.4  $\mu\text{L}$  PhSiH<sub>3</sub> (C2) in 37.6  $\mu\text{L}$  dodecane. The amount of 1-hexene (B3) was 145  $\mu\text{L}$ . Each vial was mixed overnight (for 16 h) at 50°C. The resulting contents of each vial were analyzed by GC according to the method described below.

### Example 3 - [HMTS] Reaction

**[0169]** To perform the [HMTS] reaction, 1-hexene (B3) and 1,1,1,3,5,5,5-heptamethyltrisiloxane (C1) were added to a vial prepared according to Example 1. The amount of 1-hexene added was 145  $\mu\text{L}$ . The amount of heptamethyltrisiloxane (C1) was either

312  $\mu\text{L}$  heptamethyltrisiloxane (C1) at a concentration of 3.4  $\text{M}$  (as H or SiH) in dodecane, or 290  $\mu\text{L}$  heptamethyltrisiloxane (C1) in 22  $\mu\text{L}$  dodecane. Each vial was mixed overnight (for 16 h) at 50 °C. The resulting contents of each vial were analyzed by GC according to the method described below.

5

*Example 4 – GC Measurement*

**[0170]** A gas chromatography (GC) analysis was made of the samples prepared in an example above. The GC analysis was performed with a Hewlett-Packard 7890A gas chromatograph with a flame ionization detector (FID). A Leap Combi-Pal robot was used to perform the injections in an automated manner. The system was configured as detailed in

10 Table 4.

Table 4: GC-FID Experimental Parameter Settings.

Carrier gas - 99.9998% high purity helium
Detector - FID at 280 °C, H <sub>2</sub> = 30 mL/min, Air = 300 mL/min, Make up He = 45 mL/min
GC inlet, split - 275 °C, split ratio = 200:1, constant pressure (total flow 22.5 mL/min)
GC column - Agilent Low Thermal Mass column, 350 °C, 30m X 320 $\mu\text{m}$ X 0.25 $\mu\text{m}$
GC temperature program - 55(3) to 300(5) @35 °C/min, 15 minute total run time
Internal standard - 5% (w/w) dodecane in phenylsilane
data system - Agilent Technologies ChemStation

**[0171]** The GC temperature program details are as follows in Table 5 with the oven at a constant temperature of 300 °C.

15 Table 5

LTM column 1					LTM column 2			
Rate (°C/min)	Value (°C)	*Hold Time (min)	Run time (min)		Rate (°C/min)	Value (°C)	*Hold Time (min)	Run time (min)
	100	0.5	0.5			100	2	2
50	150	0.5	2		50	150	0.5	3.5
600	300	5	7		600	300	3.5	7
		*Difference to allow for delay before second injection						

**[0172]** Dodecane was used as an internal standard to gravimetrically quantify the chromatographic analyses. Internal standard was introduced prior to reaction at 5% (w/w) from a solution of dodecane and phenylsilane. Theoretical response factors for the analytes were calculated and entered into the ChemStation to automatically create a calibration table and quantitatively calculate the concentration of an analyte in the presence of an internal standard (Equation 1).

20

$$RF_{\text{analyte}} = ([\text{analyte}]/\text{Area}_{\text{analyte}}) \times (\text{Area}_{\text{IS}}/[\text{IS}]) \times RF_{\text{IS}} \quad (1)$$

**[0173]** The terms in Equation 1 are defined as follows:  $RF_{\text{analyte}}$  = response factor for the analyte,  $[\text{analyte}]$  = concentration of the analyte,  $\text{Area}_{\text{analyte}}$  = peak area of the analyte,  $\text{Area}_{\text{IS}}$  = peak area of the internal standard,  $[\text{IS}]$  = concentration of the internal standard,  $RF_{\text{IS}}$  = response factor for the internal standard.

**[0174]** Encompassing experimental and instrumental errors, the relative standard deviation of the measurements ranged from 0.3% to 10% depending on the concentration and, correspondingly, the yield of the analyte. The results are in Table 6.

Table 6 – Results for Re Precursors

Precursor	Ligand Number	Silane	Reducing agent	ligand Micromoles	Metal:ligand	Catalytically Active ?
Re (V)	1769	HMTS	LiBArF	4.25	1:2	N
Re (V)	1769	HMTS	NaEt <sub>3</sub> BH	4.25	1:2	N
Re (V)	1769	PhSiH <sub>3</sub>	LiBArF	4.25	1:2	N
Re (V)	1769	PhSiH <sub>3</sub>	NaEt <sub>3</sub> BH	4.25	1:2	Y
Re (III)	2806	HMTS	LiBArF	4.25	1:2	N
Re (III)	2806	HMTS	NaEt <sub>3</sub> BH	4.25	1:2	N
Re (III)	2806	PhSiH <sub>3</sub>	LiBArF	4.25	1:2	N
Re (III)	2806	PhSiH <sub>3</sub>	NaEt <sub>3</sub> BH	4.25	1:2	Y
Re (III)	4548	HMTS	LiBArF	4.25	1:2	N
Re (III)	4548	HMTS	NaEt <sub>3</sub> BH	4.25	1:2	N
Re (III)	4548	PhSiH <sub>3</sub>	LiBArF	4.25	1:2	N
Re (III)	4548	PhSiH <sub>3</sub>	NaEt <sub>3</sub> BH	4.25	1:2	Y
Re (III)	7496	HMTS	LiBArF	4.25	1:2	N
Re (III)	7496	HMTS	NaEt <sub>3</sub> BH	4.25	1:2	N
Re (III)	7496	PhSiH <sub>3</sub>	LiBArF	4.25	1:2	N
Re (III)	7496	PhSiH <sub>3</sub>	NaEt <sub>3</sub> BH	4.25	1:2	Y
Re (V)	8945	HMTS	LiBArF	2.125	1:1	N
Re (V)	8945	HMTS	NaEt <sub>3</sub> BH	2.125	1:1	N
Re (V)	8945	PhSiH <sub>3</sub>	LiBArF	2.125	1:1	Y
Re (V)	8945	PhSiH <sub>3</sub>	NaEt <sub>3</sub> BH	2.125	1:1	N

## CLAIMS

1. A method comprising:

(1) combining ingredients comprising ingredient (a) and ingredient (b) to prepare a reaction product, where

5 Ingredient (a) is a Re precursor of formula (i)  $\text{Re-A}_3$ , where each A is independently a displaceable substituent, and

Ingredient (b) is a ligand selected from general formula (iii), general formula (iv), general formula (vi), Ligand 2806, Ligand 4548, and Ligand 7946; where

10

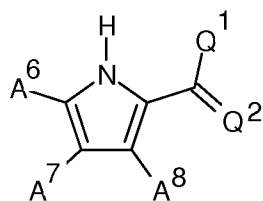

General formula (iii) is  $\text{Re-A}_3$ , where  $\text{Q}^1$  is selected from OH and SH,  $\text{Q}^2$  is selected from O and S, and  $\text{A}^6$ ,  $\text{A}^7$ , and  $\text{A}^8$  are each independently selected from H and a monovalent organic group, with the provisos that  $\text{A}^6$  and/or  $\text{A}^7$  contain at least one carbon atom and that  $\text{A}^6$  and  $\text{A}^7$  may be bonded together to form an aryl group fused with the 5 membered ring; or

15

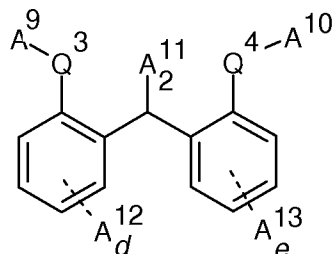

General formula (iv) is  $\text{Re-A}_3$ , where subscript  $d$  is an integer from 0 to 4, subscript  $e$  is an integer from 0 to 4,  $\text{Q}^3$  and  $\text{Q}^4$  are each independently selected from O and S,  $\text{A}^9$ ,  $\text{A}^{10}$ , and each  $\text{A}^{11}$  are each independently selected from H and a monovalent organic group, and each  $\text{A}^{12}$  and each  $\text{A}^{13}$  are independently selected from a halogen atom and a monovalent organic group; or

20

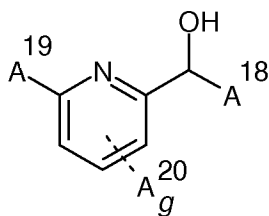

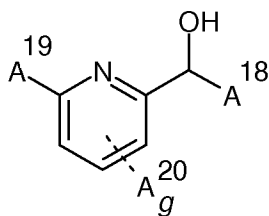
General formula (vi) is , where subscript  $g$  is an integer from 0 to 3, A<sup>18</sup> and A<sup>19</sup> are each independently a monovalent organic group, and each A<sup>20</sup> is independently a halogen atom or a monovalent organic group; or

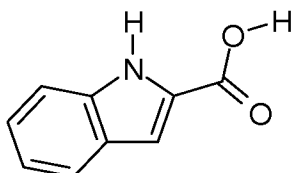

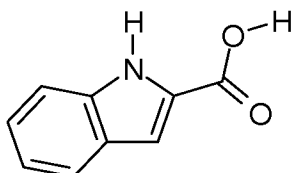
Ligand 2806 is ; or

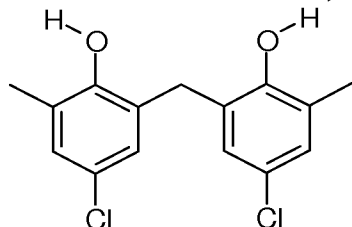

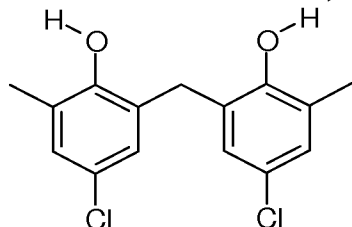
5 Ligand 4548 is ; or

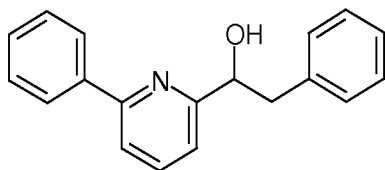

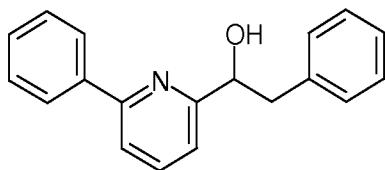
Ligand 7496 is .

2. A method comprising:

10 (1) combining ingredients comprising ingredient (a) and ingredient (b) to prepare a reaction product, where

Ingredient (a) is a Re precursor of formula (i) Re-A<sub>5</sub>, where each A is independently a displaceable substituent, and

15 Ingredient (b) is a ligand selected from general formula (ii), general formula (v), Ligand 1769, and Ligand 8945, where

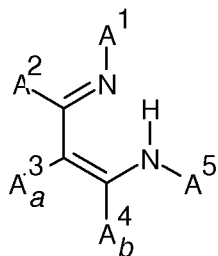

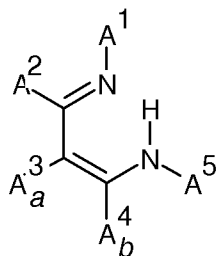
General formula (ii) is , where A<sup>1</sup>, A<sup>2</sup>, each A<sup>3</sup>, each A<sup>4</sup>, and A<sup>5</sup> are each independently selected from H and a monovalent organic group, subscript *a* is 1 or 2, subscript *b* is 1 or 2,

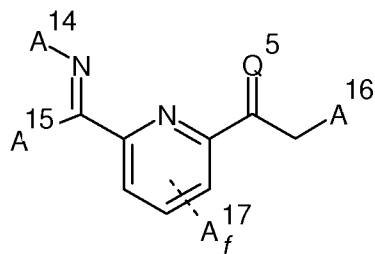

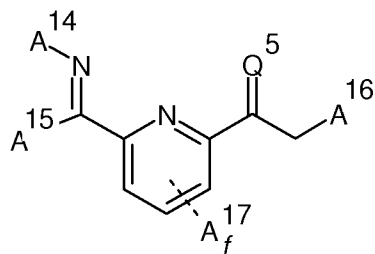
General formula (v) is , where subscript *f* is an integer from 0 to 5, Q<sup>5</sup> is selected from O and S, A<sup>14</sup>, A<sup>15</sup>, and each A<sup>16</sup> are each independently a monovalent organic group, and each A<sup>17</sup> is independently a halogen atom or a monovalent organic group; or

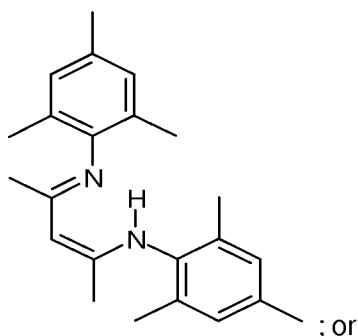

Ligand 1769 is

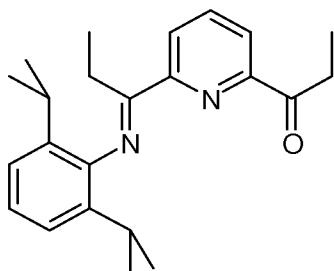

Ligand 8945 is

10

3. The method of claim 1 or claim 2, where at least one of conditions (i) – (iv) is satisfied:
  - (i) each A is independently a halogen atom or a monovalent organic group; or
  - (ii) each A is independently a halogen atom selected from Br and Cl; or

(iii) each A is independently a monovalent organic group selected from amino groups, halogenated hydrocarbon groups, silazane groups, carboxylic ester groups, carbonyl groups, hydrocarbonoxy groups, sulfonylimide groups, acetate groups, and cyano groups; or

(iv) each A is independently Cl.

5

4. The method of any one of claims 1-3, where the method further comprises: one or more of steps a)-e), where:

Step a) is activating the ligand before forming the reaction product,

Step b) is dissolving the ligand in a solvent before forming the reaction product,

10

Step c) is dissolving the M precursor in a solvent before forming the reaction product,

Step d) is heating the Re precursor and the ligand to form the reaction product,

Step e) is activating the reaction product, and

Step f) is removing a by-product from the reaction product to yield a Re-ligand complex free of the by-product.

15

5. The method of claim 4, where step e) is present, and step e) is performed by reacting the complexation reaction product with an activating agent selected from an alkali metal amalgam; a metal hydride; a metal borohydride; a metal borate; or a mixture thereof.

20

6. The method of any one of claims 1-5, further comprising using a product prepared by the method as a hydrosilylation catalyst.

7. A composition comprising:

(A) a catalytically active reaction product prepared of by the method of any one of claims 1-5;

25

and

(B) an aliphatically unsaturated compound having an average, per molecule, of one or more aliphatically unsaturated organic groups capable of undergoing hydrosilylation reaction; and

optionally (C) an SiH functional compound having an average, per molecule, of one or more silicon bonded hydrogen atoms; which is distinct from ingredients (A) and (B);

30

with the proviso that when ingredient (B) lacks a silicon bonded hydrogen atom, then the composition includes ingredient (C).

8. The composition of any claim 7, where the composition further comprises one or more additional ingredients, which are distinct from ingredients (A), (B), and (C), and which are selected from the group consisting of (D) a spacer; (E) an extender, a plasticizer, or a combination thereof; (F) a filler; (G) a filler treating agent; (H) a biocide; (I) a stabilizer, (J) a

35

flame retardant; (K) a surface modifier; (L) a chain lengthener; (M) an endblocker; (N) a flux agent; (O) an anti-aging additive; (P) a pigment; (Q) an acid acceptor; (R) a rheological additive; (S) a vehicle; (T) a surfactant; (U) a corrosion inhibitor; and a combination thereof.

5 9. A method for making the composition of claim 7 or claim 8, comprising: mixing ingredients comprising ingredients (A), (B), and (C).

10. A method for making the composition of claim 7 or 8, comprising:

10 (i) mixing ingredients comprising ingredients (A) and (B), and optionally one or more of (D), (E), (F), (G), (H), (I), (J), (K), (L), (M), (N), (O), (P), (Q), (R), (S), (T), and (U) to form a curing agent; and

(ii) mixing ingredients comprising ingredients (B) and (C) and optionally one or more of (D), (E), (F), (G), (H), (I), (J), (K), (L), (M), (N), (O), (P), (Q), (R), (S), (T), and (U) to form a base; and

(iii) mixing the curing agent and the base, so as to make the composition.

15

11. A method comprising: reacting the composition of claim 7 or claim 8, to prepare a hydrosilylation reaction product.

12. The hydrosilylation reaction product prepared by the method of claim 11.

20