



- (51) International Patent Classification:
H04L 5/00 (2006.01) *H04W 72/04* (2009.01)
- (21) International Application Number:
PCT/KR2016/015346
- (22) International Filing Date:
27 December 2016 (27.12.2016)
- (25) Filing Language: English
- (26) Publication Language: English
- (30) Priority Data:
62/271,299 27 December 2015 (27.12.2015) US
62/274,734 4 January 2016 (04.01.2016) US
62/292,168 5 February 2016 (05.02.2016) US
62/318,763 6 April 2016 (06.04.2016) US
- (71) Applicant: **LG ELECTRONICS INC.** [KR/KR]; 128, Yeoui-daero, Yeongdeungpo-gu, Seoul, 07336 (KR).
- (72) Inventors: **YI, Yunjung**; IP Center, LG Electronics Inc., 19, Yangjae-daero 11-gil, Seocho-gu, Seoul 06772 (KR).
KIM, Kijun; IP Center, LG Electronics Inc., 19, Yangjae-daero 11-gil, Seocho-gu, Seoul 06772 (KR).
- (74) Agent: **ENVISION PATENT & LAW FIRM**; 5F, 124, Teheran-ro, Gangnam-gu, Seoul 06234 (KR).

(81) Designated States (unless otherwise indicated, for every kind of national protection available): AE, AG, AL, AM, AO, AT, AU, AZ, BA, BB, BG, BH, BN, BR, BW, BY, BZ, CA, CH, CL, CN, CO, CR, CU, CZ, DE, DJ, DK, DM, DO, DZ, EC, EE, EG, ES, FI, GB, GD, GE, GH, GM, GT, HN, HR, HU, ID, IL, IN, IR, IS, JP, KE, KG, KH, KN, KP, KR, KW, KZ, LA, LC, LK, LR, LS, LU, LY, MA, MD, ME, MG, MK, MN, MW, MX, MY, MZ, NA, NG, NI, NO, NZ, OM, PA, PE, PG, PH, PL, PT, QA, RO, RS, RU, RW, SA, SC, SD, SE, SG, SK, SL, SM, ST, SV, SY, TH, TJ, TM, TN, TR, TT, TZ, UA, UG, US, UZ, VC, VN, ZA, ZM, ZW.

(84) Designated States (unless otherwise indicated, for every kind of regional protection available): ARIPO (BW, GH, GM, KE, LR, LS, MW, MZ, NA, RW, SD, SL, ST, SZ, TZ, UG, ZM, ZW), Eurasian (AM, AZ, BY, KG, KZ, RU, TJ, TM), European (AL, AT, BE, BG, CH, CY, CZ, DE, DK, EE, ES, FI, FR, GB, GR, HR, HU, IE, IS, IT, LT, LU, LV, MC, MK, MT, NL, NO, PL, PT, RO, RS, SE, SI, SK, SM, TR), OAPI (BF, BJ, CF, CG, CI, CM, GA, GN, GQ, GW, KM, ML, MR, NE, SN, TD, TG).

Published: — with international search report (Art. 21(3))

(54) Title: METHOD AND APPARATUS FOR TRANSMITTING ACK/NACK FOR NB-IOT IN WIRELESS COMMUNICATION SYSTEM

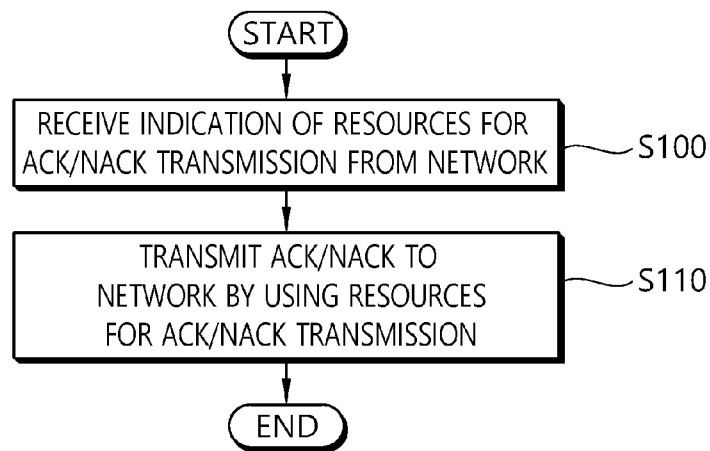

(57) Abstract: A method and apparatus for transmitting an acknowledgement/non-acknowledgment (ACK/NACK) in a wireless communication system is provided. A narrowband internet-of-things (NB-IoT) user equipment (UE) receives an indication of resources for ACK/NACK transmission from a network, and transmits the ACK/NACK to the network by using the resource for ACK/NACK transmission.

WO 2017/116120 A1

Description

Title of Invention: METHOD AND APPARATUS FOR TRANSMITTING ACK/NACK FOR NB-IOT IN WIRELESS COMMUNICATION SYSTEM

Technical Field

- [1] The present invention relates to wireless communications, and more particularly, to a method and apparatus for transmitting an acknowledgement/non-acknowledgement (ACK/NACK) for a narrowband internet-of-things (NB-IoT) in a wireless communication system.

Background Art

- [2] 3rd generation partnership project (3GPP) long-term evolution (LTE) is a technology for enabling high-speed packet communications. Many schemes have been proposed for the LTE objective including those that aim to reduce user and provider costs, improve service quality, and expand and improve coverage and system capacity. The 3GPP LTE requires reduced cost per bit, increased service availability, flexible use of a frequency band, a simple structure, an open interface, and adequate power consumption of a terminal as an upper-level requirement.
- [3] In the future versions of the LTE-A, it has been considered to configure low-cost/low-end (or, low-complexity) user equipments (UEs) focusing on the data communication, such as meter reading, water level measurement, use of security camera, vending machine inventory report, etc. For convenience, these UEs may be called machine type communication (MTC) UEs. Since MTC UEs have small amount of transmission data and have occasional uplink data transmission/downlink data reception, it is efficient to reduce the cost and battery consumption of the UE according to a low data rate. Specifically, the cost and battery consumption of the UE may be reduced by decreasing radio frequency (RF)/baseband complexity of the MTC UE significantly by making the operating frequency bandwidth of the MTC UE smaller.
- [4] Narrowband internet-of-things (NB-IoT) is a low power wide area network (LPWAN) radio technology standard that has been developed to enable a wide range of devices and services to be connected using cellular telecommunications bands. NB-IoT is a narrowband radio technology designed for the IoT, and is one of a range of mobile IoT (MIoT) technologies standardized by the 3GPP. NB-IoT focuses specifically on indoor coverage, low cost, long battery life, and enabling a large number of connected devices.
- [5] In NB-IoT, ACK/NACK transmission scheme may be different from that of con-

ventional 3GPP LTE. Accordingly, an ACK/NACK transmission method in NB-IoT may be required.

Disclosure of Invention

Technical Problem

- [6] The present invention provides a method and apparatus for transmitting an acknowledgement/non-acknowledgement (ACK/NACK) for a narrowband internet-of-things (NB-IoT) in a wireless communication system.

Solution to Problem

- [7] In an aspect, a method for transmitting an acknowledgement/non-acknowledgment (ACK/NACK) by a narrowband internet-of-things (NB-IoT) user equipment (UE) in a wireless communication system is provided. The method includes receiving an indication of resources for ACK/NACK transmission from a network, and transmitting the ACK/NACK to the network by using the resource for ACK/NACK transmission.
- [8] In another aspect, a narrowband internet-of-things (NB-IoT) user equipment (UE) in a wireless communication system is provided. The NB-IoT UE includes a memory, a transceiver, and a processor, coupled to the memory and the transceiver, that controls the transceiver to receive an indication of resources for an acknowledgement/non-acknowledgement (ACK/NACK) transmission from a network, and controls the transceiver to transmit an ACK/NACK to the network by using the resource for ACK/NACK transmission.

Advantageous Effects of Invention

- [9] ACK/NACK can be transmitted efficiently in NB-IoT.

Brief Description of Drawings

- [10] FIG. 1 shows a wireless communication system.
- [11] FIG. 2 shows structure of a radio frame of 3GPP LTE.
- [12] FIG. 3 shows a resource grid for one downlink slot.
- [13] FIG. 4 shows structure of a downlink subframe.
- [14] FIG. 5 shows structure of an uplink subframe.
- [15] FIG. 6 shows an example of resource units for PUSCH transmission according to an embodiment of the present invention.
- [16] FIG. 7 shows another example of resource units for PUSCH transmission according to an embodiment of the present invention.
- [17] FIG. 8 shows another example of resource units for PUSCH transmission according to an embodiment of the present invention.
- [18] FIG. 9 shows another example of resource units for PUSCH transmission according to an embodiment of the present invention.
- [19] FIG. 10 shows another example of resource units for PUSCH transmission according

to an embodiment of the present invention.

[20] FIG. 11 shows another example of resource units for PUSCH transmission according to an embodiment of the present invention.

[21] FIG. 12 shows an example of sub-ACK/NACK resource unit according to an embodiment of the present invention.

[22] FIG. 13 shows another example of sub-ACK/NACK resource unit according to an embodiment of the present invention.

[23] FIG. 14 shows another example of sub-ACK/NACK resource unit according to an embodiment of the present invention.

[24] FIG. 15 shows an example of TDM between ACK/NACK transmission and data transmission according to an embodiment of the present invention.

[25] FIG. 16 shows an example of ACK/NACK alignments in resource unit according to an embodiment of the present invention.

[26] FIG. 17 shows an example of ACK/NACK alignments among different PDSCH transmissions according to an embodiment of the present invention.

[27] FIG. 18 shows a method for transmitting an ACK/NACK by a NB-IoT UE according to an embodiment of the present invention.

[28] FIG. 19 shows a wireless communication system to implement an embodiment of the present invention.

Mode for the Invention

[29] Techniques, apparatus and systems described herein may be used in various wireless access technologies such as code division multiple access (CDMA), frequency division multiple access (FDMA), time division multiple access (TDMA), orthogonal frequency division multiple access (OFDMA), single carrier frequency division multiple access (SC-FDMA), etc. The CDMA may be implemented with a radio technology such as universal terrestrial radio access (UTRA) or CDMA2000. The TDMA may be implemented with a radio technology such as global system for mobile communications (GSM)/general packet radio service (GPRS)/enhanced data rates for GSM evolution (EDGE). The OFDMA may be implemented with a radio technology such as institute of electrical and electronics engineers (IEEE) 802.11 (Wi-Fi), IEEE 802.16 (WiMAX), IEEE 802-20, evolved-UTRA (E-UTRA) etc. The UTRA is a part of a universal mobile telecommunication system (UMTS). 3rd generation partnership project (3GPP) long term evolution (LTE) is a part of an evolved-UMTS (E-UMTS) using the E-UTRA. The 3GPP LTE employs the OFDMA in downlink (DL) and employs the SC-FDMA in uplink (UL). LTE-advance (LTE-A) is an evolution of the 3GPP LTE. For clarity, this application focuses on the 3GPP LTE/LTE-A. However, technical features of the present invention are not limited thereto.

- [30] FIG. 1 shows a wireless communication system. The wireless communication system 10 includes at least one evolved NodeB (eNB) 11. Respective eNBs 11 provide a communication service to particular geographical areas 15a, 15b, and 15c (which are generally called cells). Each cell may be divided into a plurality of areas (which are called sectors). A user equipment (UE) 12 may be fixed or mobile and may be referred to by other names such as mobile station (MS), mobile terminal (MT), user terminal (UT), subscriber station (SS), wireless device, personal digital assistant (PDA), wireless modem, handheld device. The eNB 11 generally refers to a fixed station that communicates with the UE 12 and may be called by other names such as base station (BS), base transceiver system (BTS), access point (AP), etc.
- [31] In general, a UE belongs to one cell, and the cell to which a UE belongs is called a serving cell. An eNB providing a communication service to the serving cell is called a serving eNB. The wireless communication system is a cellular system, so a different cell adjacent to the serving cell exists. The different cell adjacent to the serving cell is called a neighbor cell. An eNB providing a communication service to the neighbor cell is called a neighbor eNB. The serving cell and the neighbor cell are relatively determined based on a UE.
- [32] This technique can be used for DL or UL. In general, DL refers to communication from the eNB 11 to the UE 12, and UL refers to communication from the UE 12 to the eNB 11. In DL, a transmitter may be part of the eNB 11 and a receiver may be part of the UE 12. In UL, a transmitter may be part of the UE 12 and a receiver may be part of the eNB 11.
- [33] The wireless communication system may be any one of a multiple-input multiple-output (MIMO) system, a multiple-input single-output (MISO) system, a single-input single-output (SISO) system, and a single-input multiple-output (SIMO) system. The MIMO system uses a plurality of transmission antennas and a plurality of reception antennas. The MISO system uses a plurality of transmission antennas and a single reception antenna. The SISO system uses a single transmission antenna and a single reception antenna. The SIMO system uses a single transmission antenna and a plurality of reception antennas. Hereinafter, a transmission antenna refers to a physical or logical antenna used for transmitting a signal or a stream, and a reception antenna refers to a physical or logical antenna used for receiving a signal or a stream.
- [34] FIG. 2 shows structure of a radio frame of 3GPP LTE. Referring to FIG. 2, a radio frame includes 10 subframes. A subframe includes two slots in time domain. A time for transmitting one subframe is defined as a transmission time interval (TTI). For example, one subframe may have a length of 1ms, and one slot may have a length of 0.5ms. One slot includes a plurality of orthogonal frequency division multiplexing (OFDM) symbols in time domain. Since the 3GPP LTE uses the OFDMA in the DL,

the OFDM symbol is for representing one symbol period. The OFDM symbols may be called by other names depending on a multiple-access scheme. For example, when SC-FDMA is in use as a UL multi-access scheme, the OFDM symbols may be called SC-FDMA symbols. A resource block (RB) is a resource allocation unit, and includes a plurality of contiguous subcarriers in one slot. The structure of the radio frame is shown for exemplary purposes only. Thus, the number of subframes included in the radio frame or the number of slots included in the subframe or the number of OFDM symbols included in the slot may be modified in various manners.

[35] The wireless communication system may be divided into a frequency division duplex (FDD) scheme and a time division duplex (TDD) scheme. According to the FDD scheme, UL transmission and DL transmission are made at different frequency bands. According to the TDD scheme, UL transmission and DL transmission are made during different periods of time at the same frequency band. A channel response of the TDD scheme is substantially reciprocal. This means that a DL channel response and a UL channel response are almost the same in a given frequency band. Thus, the TDD-based wireless communication system is advantageous in that the DL channel response can be obtained from the UL channel response. In the TDD scheme, the entire frequency band is time-divided for UL and DL transmissions, so a DL transmission by the eNB and a UL transmission by the UE cannot be simultaneously performed. In a TDD system in which a UL transmission and a DL transmission are discriminated in units of subframes, the UL transmission and the DL transmission are performed in different subframes.

[36] FIG. 3 shows a resource grid for one downlink slot. Referring to FIG. 3, a DL slot includes a plurality of OFDM symbols in time domain. It is described herein that one DL slot includes 7 OFDM symbols, and one RB includes 12 subcarriers in frequency domain as an example. However, the present invention is not limited thereto. Each element on the resource grid is referred to as a resource element (RE). One RB includes 12×7 resource elements. The number N^{DL} of RBs included in the DL slot depends on a DL transmit bandwidth. The structure of a UL slot may be same as that of the DL slot. The number of OFDM symbols and the number of subcarriers may vary depending on the length of a CP, frequency spacing, etc. For example, in case of a normal cyclic prefix (CP), the number of OFDM symbols is 7, and in case of an extended CP, the number of OFDM symbols is 6. One of 128, 256, 512, 1024, 1536, and 2048 may be selectively used as the number of subcarriers in one OFDM symbol.

[37] FIG. 4 shows structure of a downlink subframe. Referring to FIG. 4, a maximum of three OFDM symbols located in a front portion of a first slot within a subframe correspond to a control region to be assigned with a control channel. The remaining OFDM symbols correspond to a data region to be assigned with a physical downlink

shared channel (PDSCH). Examples of DL control channels used in the 3GPP LTE includes a physical control format indicator channel (PCFICH), a physical downlink control channel (PDCCH), a physical hybrid automatic repeat request (HARQ) indicator channel (PHICH), etc. The PCFICH is transmitted at a first OFDM symbol of a subframe and carries information regarding the number of OFDM symbols used for transmission of control channels within the subframe. The PHICH is a response of UL transmission and carries a HARQ acknowledgment (ACK)/non-acknowledgment (NACK) signal. Control information transmitted through the PDCCH is referred to as downlink control information (DCI). The DCI includes UL or DL scheduling information or includes a UL transmit (TX) power control command for arbitrary UE groups.

- [38] The PDCCH may carry a transport format and a resource allocation of a downlink shared channel (DL-SCH), resource allocation information of an uplink shared channel (UL-SCH), paging information on a paging channel (PCH), system information on the DL-SCH, a resource allocation of an upper-layer control message such as a random access response transmitted on the PDSCH, a set of TX power control commands on individual UEs within an arbitrary UE group, a TX power control command, activation of a voice over IP (VoIP), etc. A plurality of PDCCHs can be transmitted within a control region. The UE can monitor the plurality of PDCCHs. The PDCCH is transmitted on an aggregation of one or several consecutive control channel elements (CCEs). The CCE is a logical allocation unit used to provide the PDCCH with a coding rate based on a state of a radio channel. The CCE corresponds to a plurality of resource element groups.
- [39] A format of the PDCCH and the number of bits of the available PDCCH are determined according to a correlation between the number of CCEs and the coding rate provided by the CCEs. The eNB determines a PDCCH format according to a DCI to be transmitted to the UE, and attaches a cyclic redundancy check (CRC) to control information. The CRC is scrambled with a unique identifier (referred to as a radio network temporary identifier (RNTI)) according to an owner or usage of the PDCCH. If the PDCCH is for a specific UE, a unique identifier (e.g., cell-RNTI (C-RNTI)) of the UE may be scrambled to the CRC. Alternatively, if the PDCCH is for a paging message, a paging indicator identifier (e.g., paging-RNTI (P-RNTI)) may be scrambled to the CRC. If the PDCCH is for system information, a system information identifier and a system information RNTI (SI-RNTI) may be scrambled to the CRC. To indicate a random access response that is a response for transmission of a random access preamble of the UE, a random access-RNTI (RA-RNTI) may be scrambled to the CRC.
- [40] FIG. 5 shows structure of an uplink subframe. Referring to FIG. 5, a UL subframe

can be divided in a frequency domain into a control region and a data region. The control region is allocated with a physical uplink control channel (PUCCH) for carrying UL control information. The data region is allocated with a physical uplink shared channel (PUSCH) for carrying user data. When indicated by a higher layer, the UE may support a simultaneous transmission of the PUSCH and the PUCCH. The PUCCH for one UE is allocated to an RB pair in a subframe. RBs belonging to the RB pair occupy different subcarriers in respective two slots. This is called that the RB pair allocated to the PUCCH is frequency-hopped in a slot boundary. This is said that the pair of RBs allocated to the PUCCH is frequency-hopped at the slot boundary. The UE can obtain a frequency diversity gain by transmitting UL control information through different subcarriers according to time.

- [41] UL control information transmitted on the PUCCH may include a HARQ ACK/NACK, a channel quality indicator (CQI) indicating the state of a DL channel, a scheduling request (SR), and the like. The PUSCH is mapped to a UL-SCH, a transport channel. UL data transmitted on the PUSCH may be a transport block, a data block for the UL-SCH transmitted during the TTI. The transport block may be user information. Or, the UL data may be multiplexed data. The multiplexed data may be data obtained by multiplexing the transport block for the UL-SCH and control information. For example, control information multiplexed to data may include a CQI, a precoding matrix indicator (PMI), an HARQ, a rank indicator (RI), or the like. Or the UL data may include only control information.
- [42] In the current LTE specification, all UEs shall support maximum 20MHz system bandwidth, which requires baseband processing capability to support 20MHz bandwidth. To reduce hardware cost and battery power of MTC UEs, reducing bandwidth is a very attractive option. To enable narrowband MTC UEs, the current LTE specification shall be changed to allow narrowband UE category. If the serving cell has small system bandwidth (smaller than or equal to bandwidth that narrow-band UE can support), the UE can attach based on the current LTE specification.
- [43] For example, a MTC UE may operate in reduced UE downlink and/or uplink bandwidth of 1.4 MHz (i.e. 6 PRBs), regardless of operating system bandwidth of a cell. A subband in which a MTC UE operates (i.e. MTC subband) may be located in a center of the system bandwidth (e.g. center 6 PRBs). Alternatively, multiple subbands in which multiples MTC UEs operates may be allocated in one subframe for multiplexing of the multiple MTC UEs. In this case, the multiple UEs may use different subbands from each other, or, may use the same subband (not center 6 PRBs).
- [44] Further, a MTC UE may operate in further reduced UE downlink and/or uplink bandwidth of 200 kHz (i.e. 1 PRB). This may be referred to as a narrowband internet-of-things (NB-IoT). Narrowband IoT (NB-IoT) may provide access to network

services using physical layer optimized for very low power consumption (e.g. full carrier bandwidth is 180 kHz, subcarrier spacing can be 3.75 kHz or 15 kHz). A number of E-UTRA protocol functions supported by all Rel-8 UEs may not be used for NB-IoT and need not be supported by eNBs and UEs only using NB-IoT. In NB-IoT, the MTC UE may operate in a legacy cell which has a system bandwidth wider than 200 kHz with backward compatibility. This system may be referred to as in-band NB-LTE. Alternatively, the MTC UE may operate in a frequency, in which the legacy cell does not exist and only for the MTC UE. This system may be referred to as stand-alone NB-LTE.

- [45] Coverage enhancement (CE) for the MTC UE is described. When a UE performs initial access towards a specific cell, the UE may receive master information block (MIB), system information block (SIB) and/or radio resource control (RRC) parameters for the specific cell from an eNB which controls the specific cell. Further, the UE may receive PDCCH/PDSCH from the eNB. In this case, the MTC UE should have broader coverage than the legacy UE. Accordingly, if the eNB transmits MIB/SIB/RRC parameters/PDCCH/PDSCH to the MTC UE with same scheme as the legacy UE, the MTC UE may have difficulty for receiving MIB/SIB/RRC parameters/PDCCH/PDSCH. To solve this problem, when the eNB transmits MIB/SIB/RRC parameters/PDCCH/PDSCH to the MTC UE having coverage issue, the eNB may apply various schemes for coverage enhancement, e.g. subframe repetition, subframe bundling, etc.
- [46] When a MTC UE having coverage issue uses the same service in the same cell with a legacy UE or a MTC UE not having coverage issue, a large amount of resources may be used to transmit data to the MTC UE having coverage issue. It may restrict services for other UEs. Therefore, in order to avoid the problem that an operation for the MTC UE having coverage issue may interference an operation for other UEs, a time region for the MTC UE having coverage issue and a time region for other UEs may be multiplexed by time division multiplexing (TDM). The time region for the MTC UE having coverage issue and time region for other UEs may be multiplexed with a long-term period, e.g. tens of minutes, or with a short-term period, e.g. some subframes.
- [47] Hereinafter, a MTC UE, a UE requiring coverage enhancement (CE), a low cost UE, a low end UE, a low complexity UE, a narrow(er) band UE, a small(er) band UE, a new category UE, a bandwidth reduced low complexity UE (BL UE), NB-IoT UE, or NB-LTE UE may have the same meaning, and may be used mixed. Or, just a UE may refer one of UEs described above. Further, in the description below, a case where system bandwidth of available cells is larger than bandwidth that new category narrowband UEs can support may be assumed. For the new category UE, it may be assumed that only one narrow-band is defined. In other words, all narrow-band UE

shall support the same narrow bandwidth smaller than 20MHz. It may be assumed that the narrow bandwidth is larger than 1.4MHz (6 PRBs). However, the present invention can be applied to narrower bandwidth less than 1.4MHz as well (e.g. 200 kHz), without loss of generality. In these cases, the UE may be able to receive only a limited number of PRBs or subcarriers. Furthermore, in terms of UL transmission, a UE may be configured or scheduled with single or less than 12 tones (i.e. subcarriers) in one UL transmission to enhance the coverage by improving peak-to-average power ratio (PAPR) and channel estimation performance.

[48] In NB-IoT, it is expected that different resource unit definition, compared to the conventional subframe or physical resource block, in DL and UL may be used. In PUSCH transmission, in order to allow reasonable transport block (TB) size carried in one resource unit, a resource unit for NB-IoT may be considered. One resource unit may be one or some portion of one PRB in LTE, which corresponds to 14 OFDM symbols with 12 subcarriers. Regardless of whether the resource unit follows the same number of REs or not, the resource unit is expected to transmit one PUSCH.

[49] In terms of resource unit definitions for PUSCH transmission, one of the followings may be considered.

[50] (1) One TTI: The resource unit is used to schedule one TB. One TTI may consist of multiple resource units which may be spread over frequency and/or time. TTI may be changed dynamically depending on the scheduled resource units in time domain. Or, TTI may be fixed by higher layer configuration.

[51] Repetition may occur in TTI level. Minimum TTI size may be configured by the network, and repetition may occur over minimum TTI. For example, minimum TTI size may be one resource unit. One resource unit may be a default value for minimum TTI. If a UE is configured with larger number of resource units than minimum TTI, repetition may occur continuously over the scheduled resource units. Otherwise, repetition may occur over minimum TTI. If scheduled resource units is smaller than the configured minimum TTI size, repetition may occur over the scheduled resource units in continuous manner. If minimum TTI is configured, resource index may be mapped within resource units in the minimum TTI. The total size of resource index may be used for data scheduling. The minimum TTI may be configured per coverage class or per UE. The minimum TTI may also be configured to achieve time-diversity. When relatively larger minimum TTI is configured, latency may increase, but time-diversity gain may be achieved.

[52] In case of control channel, minimum TTI or the number of resource units used for control channel multiplexing may also be considered. The number of resource units used for control channel multiplexing is the size of resource units where UEs can be multiplexed. The number of resource units may be jointly signaled with repetition

number. Or, the number of resource units may be inferred from transport block size (TBS). In other words, a UE may be dynamically indicated with the number of repetitions, and the UE may infer the number of resource units used in transmission based on TBS. For example, instead of indicating TBS index, actual TB size may be signaled assuming the same code rate used. Or, a table including code rate, TBS and the number of resource units may be used to indicate the resource unit size, code rate and TBS. The value range of resource units may be $[1 \dots N]$, where N may be 6 to accommodate 100 bits. When minimum TTI is configured which is larger than one resource unit, within one minimum TTI, the scheduled resource units may be further indicated by the starting offset in resource units.

[53] (2) One resource unit: This is similar to PRB in legacy system. One resource unit is the minimum resource block size where PUSCH can be scheduled. When single tone transmission is used, the number of bits transmittable in legacy TTI length (1ms) is very limited. Moreover, considering PAPR issue, if binary phase shift keying (BPSK) or $\pi/2$ BPSK is used in single tone transmission, further restriction of bit size is expected. Moreover, demodulation reference signal (DM-RS) in 1ms (based on legacy pattern) with single tone is very short. Thus, increasing the size of resource in time (e.g. k ms) seems necessary. For example, when single tone is used for one resource unit, one resource unit may consist of single tone in k ms. Resource unit is used in resource allocation. If resource unit is multiple in frequency and time domains within one TTI, resource allocation may be jointly performed. Or, resource unit may be indexed from frequency first and then time second.

[54] To be able to transmit reasonable TBS (e.g. minimum payload of Msg 3 transmission), one resource unit may include at least about 168 REs using BPSK and 84 REs using quadrature phase shift keying (QPSK), assuming minimum size of 56 bits. The size of k may be dependent on the number of DM-RS symbols in 1ms. Assuming 4 OFDM symbols in 14 OFDM symbols are used for DM-RS, k may be about 16 using BPSK and 8 using QPSK. However, data mapping to allow symbol combining may be beneficial particularly in deep coverage case. Moreover, it may reduce PAPR by repeating the same data continuously. In that case, if p repetition is used for symbol combining, one resource unit may be multiple of p (i.e. $k * p$). This may be used only in case of BPSK is used or deep coverage case.

[55] In summary, a resource unit may consist of REs in m subcarrier within k ms. In case of BPSK is used in single tone, k may be 16. Otherwise, k may be 8. For other values of m (i.e. $m=4, 8, 12$), the k may be (2, 1, 1), respectively.

[56] FIG. 6 shows an example of resource units for PUSCH transmission according to an embodiment of the present invention. FIG. 6 corresponds to a case that subcarrier spacing is 3.75 kHz. Referring to FIG. 6, one resource unit for PUSCH transmission

includes a single tone across multiple subframes. Resource units are indexed from 0 to M-1.

[57] FIG. 7 shows another example of resource units for PUSCH transmission according to an embodiment of the present invention. FIG. 7 corresponds to a case that subcarrier spacing is 15 kHz. Referring to FIG. 7, one resource unit for PUSCH transmission may include a single tone or two tones across multiple subframes. Resource units are indexed from 0 to L-1 by frequency first, and the remaining resource units are indexed from L+N to L+N+L-2.

[58] FIG. 8 shows another example of resource units for PUSCH transmission according to an embodiment of the present invention. Referring to FIG. 8, one TTI includes two resource units with single tone, two resource units with two tones and one resource unit with four tones. Resource unit with single tone occupies 20 subframes, resource unit with two tones occupies 10 subframes, and resource unit with four tones occupies 5 subframes. In this case, resource units within one TTI may be indexed by frequency first and time second principle.

[59] FIG. 9 shows another example of resource units for PUSCH transmission according to an embodiment of the present invention. One TTI may include multiple resource units and one TB may be scheduled over multiple resource units. In this case, continuous resource unit allocation in frequency or in tone may be desired with hopping. Accordingly, the resource units may be indexed from the smallest resource unit to the largest resource unit. Referring to FIG. 9, resource units are indexed from resource units with single tone by frequency first and time second (0, 1, 2, 3...), and resource units with two tones by frequency first and time second (2k, 2k+1, 2k+2, 2k+3...), and resource units with four tones by frequency first and time second (3k, 3k+1, 3k+2, 3k+3...). Resource allocation may be based on contiguous allocation using compact format. In this case, the TB size schedulable in one TTI may be different based on number of tones used or number of resource units scheduled.

[60] Further, in order to minimize PAPR/cubic metric (CM), repetition may occur in symbol level, TTI level and/or resource unit levels. In this case, the resource mapping within one resource unit may consist of multiple symbol repetitions with multiple symbols.

[61] Alternatively, resource units may be defined per number of tones, and resource units per each number of tones may be overlapped.

[62] FIG. 10 shows another example of resource units for PUSCH transmission according to an embodiment of the present invention. Referring to FIG. 10, one resource unit for PUSCH transmission includes a single tone across k ms. Resource units are indexed from 0 to L-1.

[63] FIG. 11 shows another example of resource units for PUSCH transmission according

to an embodiment of the present invention. Referring to FIG. 11, one resource unit for PUSCH transmission includes two tones across $k/2$ ms. Resource units are indexed from 0 to $L/2-1$.

- [64] Referring to FIG. 10 and 11, when more than one tone is used for PUSCH transmission, the length of resource unit in time may be adapted to include the same number of REs to carry the minimum TBS. That is, in FIG. 10, a length of one resource unit with single tone in time is k , whereas, in FIG. 11, a length of one resource unit with two tones in time is $k/2$.
- [65] The index of resource unit in frequency may be mapped per each number of tones, e.g. L resource units in frequency domain for single tone ($L=12$ in 15 kHz subcarrier spacing, $L=48$ in 3.75 kHz subcarrier spacing). Different number of tones may be multiplexed by TDM. A cell-specific configuration of {number of subcarriers, duration, periodicity, offset} may be configured (one or more parameters may be given with default values). Alternatively, Different number of tones may be multiplexed by FDM. A cell-specific configuration of {number of subcarrier/tones, number of resource units in frequency, starting tone index, end tone index} may be configured. Hybrid of TDM and FDM may also be considered.
- [66] Depending on the number of available number of resource units in frequency domain, the size of resource allocation can be different. To avoid the change of size of resource allocation, one resource unit may cover both time domain and frequency domain. For example, resource units within L subcarriers in k ms may be used for resource allocation in a continuous resource mapping manner. Alternatively, starting tone index, among L subcarriers which is the number of tones used for transmission, may be used. L may be semi-statically configured. In other words, when one resource unit consists of multiple tones, resource unit may start in any tone index rather than fixed in a few tone indices.
- [67] In addition to the resource unit for PUSCH transmission in NB-IoT, a resource unit for ACK/NACK transmission in NB-IoT may be further defined. Hereinafter, a basic resource unit definition for ACK/NACK transmission and HARQ timing according to an embodiment of the present invention is described. The following shows some examples of the resource unit for ACK/NACK transmission.
- [68] (1) 12 subcarriers in 1 ms in DL and 1 subcarrier in X ms in UL: if this resource unit is used, UL resource unit length is X times longer than DL resource unit length.
- [69] (2) K subcarriers in m ms in DL and 1 subcarrier in X ms in UL
- [70] (3) 1 subcarrier in 1 ms in both DL and UL
- [71] (4) K subcarriers in 1 ms in DL and 1 subcarrier in 1 ms in UL
- [72] Depending on the definition of the resource unit, the number of NB-IoT DL carriers, and the number of NB-IoT UL carriers capable of ACK/NACK transmission, the

number of UEs which can be multiplexed at the same time on the same resource may be defined. For example, regardless of the definition of the resource unit, if the minimum size of scheduling of PDSCH is 1 DL resource unit and the minimum size of transmission of ACK/NACK transmission is 1 UL resource unit, one of the following options may be considered.

[73] (1) Option 1: Only one UE may always be allocated to the resource for ACK/NACK transmission corresponding to one PDSCH (1 bit transmission in one resource unit). In such case, if the first example of the definition of the resource unit (i.e. 12 subcarriers in 1 ms in DL and 1 subcarrier in X ms in UL) or the second example of the definition of the resource unit (i.e. K subcarriers in m ms in DL and 1 subcarrier in X ms in UL), FDM with other UL transmissions, such as other ACK/NACK transmission or data transmission, may be considered.

[74] (2) Option 2: Multiple UEs may be allocated to the resource for ACK/NACK transmission, as 1 UL resource unit can accommodate more than one ACK/NACK transmissions. In such case, ACK/NACK for multiple UEs may be multiplexed by code division multiplexing (CDM). Or, ACK/NACK for multiple UEs may be multiplexed by time division multiplexing (TDM) by dividing one UL resource unit into sub-ACK/NACK resource unit.

[75] (3) Option 3: Smaller granularity of resource unit may be determined for ACK/NACK transmission which is different from resource unit for data transmission. Smaller granularity of resource unit may be referred to as sub-ACK/NACK resource unit. In such case, ACK/NACK transmission may start in the middle of one UL resource unit.

[76] If option 2 or 3 described above is used, there may be multiple UEs corresponding to the same ACK/NACK transmission timing. In such case, for example, $\text{ceil}(\text{Max_Num_Subcarrier}/K)$ or $\text{Max_Num_Subcarrier}$ (which can be corresponding to the same NB-IoT UL carrier) may be multiplexed by either of CDM, TDM or frequency division multiplexing (FDM).

[77] Option 3 will be described in detail. The question of the resource unit for NB-IoT may be whether or not to use the same resource unit for ACK/NACK transmission as data transmission. If the same resource unit is used for ACK/NACK transmission and data transmission, overall latency may increase. For example, if single tone transmission is used, one resource unit may be length of 12 or 10 or 40 or 20 or 8 ms (and 12 subframes). In other words, the resource unit duration may be k ms, and k may be one of among {8, 10, 12, 20, 40}. In such case, if CDM among different ACK/NACK transmissions are not achieved, to transmit one bit, overall about 168 REs (or 168 repetitions) may be used. This type of repetition may be necessary only for UEs with extreme coverage. However, it may be very excessive for some UEs with

relatively good coverage. In that sense, the basic resource unit may be defined based on coverage level. For example, if there are three coverage levels, the following approach (or similar approaches) may be used as an example or in principle.

- [78] (1) Coverage level 1: If CDM or multiplexing in the same resource among multiple UEs are not used, 1 ms with single or multiple tones may be assumed to be a sub-ACK/NACK resource unit. Since CDM is not used, selection of the sub-ACK/NACK resource unit may be used to multiplex multiple UEs. Depending on resource of control channel (to schedule DL traffic) or resource of DL transmission, the resource for ACK/NACK transmission may be selected.
- [79] For one of mapping mechanisms, the resource for ACK/NACK transmission may be selected based on starting (E)CCE or starting index of control channel transmission. If CCE or multiplexing of different control channels are used, the starting resource index of control channel may be used to select the sub-ACK/NACK resource unit within one resource unit.
- [80] FIG. 12 shows an example of sub-ACK/NACK resource unit according to an embodiment of the present invention. Referring to FIG. 12, in one PUSCH resource unit, there are multiple sub-ACK/NACK resource units, and each of the sub-ACK/NACK resource units are selected based on CCE index.
- [81] FIG. 13 shows another example of sub-ACK/NACK resource unit according to an embodiment of the present invention. Referring to FIG. 13, if multiple tones are available for ACK/NACK transmission, the resource may be determined from the lowest (or highest) tone index) and then move to the next tone.
- [82] Alternatively, ACK/NACK resources may be mapped from the frequency first and time next. In this case, the maximum number of tones usable for ACK/NACK transmission resource needs to be configured in prior via higher layer signaling or predefined. Alternatively, ACK/NACK resources may be mapped based on location (in terms of time or frequency) of starting transmission of data channel. Alternatively, ACK/NACK resources may be mapped based on a gap between control channel and data channel. For example, if control channel indicates the gap between two channels for better TDM multiplexing, the gap may be used to determine the time resource or sub-ACK/NACK resource unit index within one PUSCH resource unit. Alternatively, ACK/NACK resources may be mapped based on UE-ID or some other higher layer configuration.
- [83] (2) Coverage level 2: Similar mechanism as coverage level 1 may be considered. However, in coverage level 2, the sub-ACK/NACK resource unit may be larger than that of coverage level 1. To allow multiplexing, the same sub-ACK/NACK resource unit may be used regardless of coverage level. In this case, some repetition may be necessary which occur in PUSCH resource unit (i.e. discontinuous repetition across

PUSCH resource units).

[84] (3) Coverage level 3: Similar mechanism as coverage level 1 may be considered. Also, the same resource unit size as PUSCH resource unit may be used. In this case, similar mechanism to schedule PUSCH may be considered. For example, explicit time resource may be dynamically indicated from DCI.

[85] In order to allow efficient channel estimation and reasonable amount of resource, one resource unit for multiplexing multiple ACK/NACK transmissions may be determined as follows. If a single tone is used for ACK/NACK transmission, $m \cdot k$ subframes may be one resource unit. m is the number of subframes used for one sub-ACK/NACK resource unit. For example, $m=4$, $k=12$. If repetition or more than m REs are needed for ACK/NACK transmission for a UE, repetition across resource units are used. If multiple tones are used for ACK/NACK transmission, $\min(r, m) \cdot \text{floor}(m / \text{floor}(12/l)) \cdot k$ subframes may be one resource unit. r is the number of minimum repetition in a coverage level. In other words, different size of resource unit may be used per coverage level.

[86] FIG. 14 shows another example of sub-ACK/NACK resource unit according to an embodiment of the present invention. Referring to FIG. 14, one tone (sub-ACK/NACK resource unit) in each side within 180 kHz may be reserved for ACK/NACK transmission. When frequency for ACK/NACK transmission is reserved, slot hopping or subframe hopping or multiple-subframes hopping may be considered. Given that only single tone is used for ACK/NACK transmission and the number of REs for DM-RS is also limited, multiple-subframes hopping rather than slot level hopping or subframe level hopping may be preferred. If frequency hopping is used, $2 \cdot m \cdot 12$ REs are used for one ACK/NACK transmission in one ACK/NACK resource unit. Repetition may occur across ACK/NACK resource units. There may be multiple PUSCH resource units corresponding to one ACK/NACK resource unit. Furthermore, depending on the number of tones used for PUSCH transmission, the shorter resource unit size in time may be used. In such case, more PUSCH resource units may be formed within one ACK/NACK resource unit. Furthermore, if 3.75 kHz is used for ACK/NACK transmission, the duration becomes about 4x times. In this case, more PUSCH resource units may be formed within one ACK/NACK resource unit. The ACK/NACK transmission may start at the first ACK/NACK resource unit after k ms since the last subframe of PDSCH transmission or last subframe of last PDSCH resource unit where PDSCH is transmitted. In FDD, $k=4$.

[87] Hereinafter, various aspects of ACK/NACK transmission by using the new resource unit according to an embodiment of the present invention will be described below.

[88] (1) TDM of ACK/NACK transmission and data transmission

[89] When resource unit for ACK/NACK transmission is smaller than resource unit for

data transmission (i.e. either option 2 or option 3 described above), the usable ACK/NACK resource to allow possible UE multiplexing may be multiplexed via FDM or TDM. When FDM is used for ACK/NACK resource multiplexing, to restrict the impact on scheduling of PUSCH, some TDM restriction of ACK/NACK resource may be considered.

- [90] For example, a few subframes in the beginning and the ending of M subframes may be reserved for ACK/NACK transmission, whereas other subframes may be used for K resource units for PUSCH transmission. For example, M=40 and one UL resource unit is 1 subcarrier * 12 subframes. 3 UL resource unit may be used for PUSCH transmission and remaining subframes, i.e. each of 2 subframes in the beginning and ending, may be used for ACK/NACK transmission. In terms of timing, ACK/NACK transmission may occur in the first available ACK/NACK subframe after k subframe since the last transmission of DL data.
- [91] When multiple NB-IoT UL carriers are used, different ACK/NACK resources and data multiplexing per UL carrier may also be configured. From a UE perspective, if a UE hops across different NB-IoT UL carriers, the resource multiplexing between ACK/NACK and data may be aligned across NB-IoT UL carriers.
- [92] Considering potentially variable DL traffic volumes (or UL/DL ratio) per applications or depending on time (e.g. firmware update requires heavy DL), K number of UL resource units may be configured between ACK/NACK resources. K may be 0, 1, 2,...Max_K. It may be assumed that one ACK/NACK resource contains at least m subframe (e.g. m=2) in time. By adjusting or configuring K, the number of ACK/NACK resource may be adjusted depending the DL traffic. If necessary, repetition may occur in consecutive ACK/NACK resource subframes. The number m can be larger than 2, e.g. 4 or 8, considering multiple-subframe channel estimation and I/Q combining.
- [93] K may be configured by the network via SIB signaling or higher layer signaling or via MIB. K may be a cell-specific value or coverage level specific value. K may also be UE-specific value. When K is configured, ACK/NACK resource may start from SFN=0 with subframe index=0, unless any offset is configured to start ACK/NACK resource. When K is configured per coverage level, the number m may be also different per coverage class, and also be configured per coverage class. If K is configured by cell-specifically, the number m may also be configured by cell-specifically. In other words, K and m may be configured together. Also, the usable number of tones may be configured. As default value, it may be assumed that 12 (for 15 kHz subcarrier spacing) and 48 (for 3.75 kHz subcarrier spacing) are usable by ACK/NACK transmission for FDM. In case of 3.75 kHz, some other default value considering frequency reuse less than 1 may also be considered.

- [94] FIG. 15 shows an example of TDM between ACK/NACK transmission and data transmission according to an embodiment of the present invention. Referring to FIG. 15, in the first NB-IoT UL carrier, two UL resource units are configured between ACK/NACK resources. A total of 4 subframes occupy ACK/NACK resources in M subframes. In the second NB-IoT UL carrier, ACK/NACK resources occupy each of 2 subframes in the beginning and ending of each M subframes, i.e. total of 4 subframes.
- [95] (2) FDM of ACK/NACK transmission and data transmission
- [96] When TDM among multiple UEs for ACK/NACK transmissions are used, FDM of ACK/NACK resource and PUSCH resource may be considered. If more than one sub-ACK/NACK resource unit is needed for ACK/NACK transmission due to repetition, the repetition may occur continuously or discontinuously. Repetition may occur continuously starting from the first sub-ACK/NACK resource unit in case of continuous repetition. In this case, the collision among different UEs needs to be addressed by the network scheduling to avoid collision. Alternatively, repetition may occur in resource unit level, and multiple UEs may be multiplexed by using different sub-ACK/NACK resource unit. Considering that it is likely that DL transmissions among multiple UEs may also be multiplexed by TDM rather than FDM, continuous repetition may work.
- [97] When multiple NB-IoT UL carriers are used for NB-IoT UL transmission with FDM between ACK/NACK transmission and data transmission, ACK/NACK resource may be configured in multiple NB-IoT UL carriers rather than per NB-IoT carrier to allow more data resources. For example, ACK/NACK resource may be configured in every 'm' number of NB-IoT UL carrier at edge of 'm' NB-IoT UL carriers. Or, only one ACK/NACK resource may be configured in multiple configured NB-IoT UL carriers. Also, the number of subcarriers/tones usable for ACK/NACK resources may be configured as well (e.g. from 1 to a few subcarriers). The configuration may be given by SIB. If ACK/NACK resource is configured across more than one NB-IoT UL carrier, frequency retuning may be necessary to switch from one NB-IoT UL carrier to another NB-IoT UL carrier. When retuning is needed within one ACK/NACK transmission with repetition, some retuning latency may be considered by puncturing retuning gaps or not utilizing a slot or subframe.
- [98] Further, when FDM of ACK/NACK transmission and data transmission is used, TDM may be used for DL transmissions among multiple UEs in different coverage class. In this case, ACK/NACK transmission among multiple UEs in TDM may be desirable. In terms of control channel, the maximum repetition level R may be defined per coverage class, and a UE may monitor multiple repetition numbers, such as R/4, R/2, R. The control channel may be transmitted with different repetition number and a UE may monitor multiple starting subframes/instances within one monitoring occasion which is defined by the maximum repetition level R. ACK/NACK transmission may

start at $n+k$ (e.g. $k=4$), and n is the last subframe where PDSCH is transmitted.

- [99] If FDM between data transmissions of multiple UE is used, some type of multiplexing among multiple ACK/NACK transmissions may be necessary. FDM among multiple ACK/NACKs may be considered aligned with data multiplexing.
- [100] (3) Collision handling between ACK/NACK transmission and data transmission via scheduling
- [101] For data and ACK/NACK resource sharing, multiplexing among PUSCH and PUCCH may be done based on scheduling. ACK/NACK may be transmitted in any resource by using FDM or TDM or CDM and the collision between PUSCH and ACK/NACK transmission may be avoided by the network scheduling. In this case, the resource used for ACK/NACK transmission and/or data transmission including frequency and time information may be indicated dynamically. Time information may include delay between UL grant and the actual UL transmission (for data transmission case) and/or between the last subframe of PDSCH transmission and actual ACK/NACK transmission (for ACK/NACK transmission case). If scheduling is used for multiplexing of ACK/NACK resource and data resource, the subcarrier index or tone index of ACK/NACK resource may be indicated dynamically in DL grant, in order to avoid potential collision. In this case, the timing may be determined implicitly. The subcarrier index or tone index of ACK/NACK resource may be indicated from a subset of tones/subcarriers usable for ACK/NACK transmission. Tones/subcarriers usable for ACK/NACK transmission may be semi-statically configured per UE or per cell. The concept may be similar to ACK/NACK resource indicator (ARI).
- [102] (4) Hybrid of TDM and FDM
- [103] In terms of resource allocation or multiplexing between ACK/NACK transmission and data transmission, hybrid approach of (1) and (2) may be considered. In other words, for configuring ACK/NACK resource, at least one of the followings may be considered.
- [104] - Periodicity of ACK/NACK resource
- [105] - Duration of ACK/NACK resource in one period (i.e. how many subframes or resource units may be used for ACK/NACK resource in each period)
- [106] - Offset of ACK/NACK resource
- [107] - Number of subcarriers used for one ACK/NACK transmission
- [108] - Number of total subcarriers usable for ACK/NACK transmission (or the offset in frequency where PUSCH should not be mapped)
- [109] The configuration may be given per coverage class, and/or per NB-IoT UL carrier and/or per legacy UL carrier and/or the total NB-IoT UL carriers and/or per UE.
- [110] Hereinafter, an ACK/NACK transmission channel according to an embodiment of the present invention is described. To transmit ACK/NACK, one of the following ap-

proaches may be considered.

- [111] First, the same channel where data is transmitted (e.g. PUSCH) may be used for ACK/NACK transmission channel. Since TB size is very small, to transmit ACK/NACK over PUSCH, the first TB size may be increased by repeating ACK/NACK bit(s) to make M TBS. After encoding, different from PUSCH encoding, CRC may not be added to avoid some overhead. Or, ACK/NACK may be transmitted only if PUSCH is scheduled, and may not be transmitted if PUSCH is not scheduled.
- [112] Alternatively, instead of utilizing PUSCH, different channel may be used for ACK/NACK transmission channel. For example, DM-RS over, e.g. 1ms, may be used to transmit ACK/NACK. In 1ms, there may be 14 OFDM symbols. In this case, ZC sequence with length of 14 may be used. Or, BPSK or QPSK codes (e.g. $\pi/2$ BPSK or $\pi/4$ QPSK modulation) may be used to transmit ACK/NACK. Alternatively, complementary Golay sequence may also be used to transmit ACK/NACK with different CS for different UEs and/or ACK/NACK status. If the minimum duration becomes larger or smaller, the length of sequence may be larger or smaller. Depending on the size of sequence, CDM among multiple UEs may also be considered.
- [113] In terms of conveying ACK or NACK, only ACK may be transmitted. In this case, discontinuous transmission (DTX) and NACK may be treated equally. Alternatively, only NACK may be transmitted. The eNB may retransmit data only when it has received NACK. If NACK transmission fails, RLC retransmission may be used. Alternatively, either ACK or NACK may be transmitted using different root sequence or CS or OCC. A set of root sequences/CSs/OCCs may be determined per UE. For example, if 12 CSs are available, 6 UEs may be multiplexed and 2 CS values may be used to differentiate ACK and NACK per UE.
- [114] When new channel is introduced, similar approach to legacy PUCCH format 1a may be considered. In this case, the format may be expanded to multiple subframes in case single tone transmission is allowed.
- [115] Alternatively, a new channel may be defined for ACK/NACK transmission channel. In this case, $\pi/2$ BPSK single tone transmission may be utilized, and at least 2 DM-RS per slot may be used. To enhance the number of DM-RS REs, two tones may be used for ACK/NACK transmission at least with 15 kHz subcarrier spacing. In terms of DM-RS, 3 DM-RS REs per slot may also be considered. 4 REs may be used for transmitting one bit ACK/NACK with 4 repetitions. In this case, the minimum size of ACK/NACK transmission may be 1 slot (or 1 subframe). For DM-RS scrambling, it's not expected to have orthogonal cover code (OCC) as multiplexing among ACK/NACK transmissions may not be achieved via CDM. Depending on the number of DM-RS within one slot, the sequence may be determined as follows.
- [116] - If the total number of REs within one ACK/NACK transmission (without counting

- repetition, i.e. there is a maximum size where one DM-RS sequence can be transmitted) exceeds 24, ZC with group hopping may be used.
- [117] - If total number of REs within one ACK/NACK transmission is less than 12, truncated DM-RS sequence with 12 length sequence may be used.
- [118] - If total number of REs within one ACK/NACK transmission is less than 24, truncated DM-RS sequence with 24 length sequence may be used.
- [119] Alternatively, for ACK/NACK transmission, scrambling code may be used differently depending on ACK or NACK on the previously received PDSCH on PUSCH transmission. If the network requires to receive ACK and/or NACK, the network may schedule a UL grant and the UE may transmit at least padding regardless of whether there is data to transmit. When the UE transmits PUSCH, the UE may use different scrambling to convey the information of the previously received PDSCH transmission. To avoid stale information, the timer may exist which defines the time window between PUSCH transmission to the lastly received PDSCH. If there is no PDSCH has been received during the window, NACK may be used for scrambling. Alternatively, one additional bit may be added to the data to deliver ACK/NACK. This approach is to transmit ACK/NACK only if a UE transmits PUSCH via piggybacking or some other means (e.g. scrambling or DM-RS sequence root sequence or cyclic shift value). To minimize the overhead of additional ACK/NACK bit addition, in UL grant, the network may trigger ACK/NACK piggyback or not.
- [120] Support of either single-tone ACK/NACK transmission or multi-tone ACK/NACK transmission according to an embodiment of the present invention is described. When a UE is configured with 3.75 kHz subcarrier spacing, the UE may not support multi-tone ACK/NACK transmission. In this case, handling of ACK/NACK transmission may be utilize only PUSCH format, and new signal may not be introduced just to support single tone with 3.75 kHz subcarrier spacing. If a new channel or signal is introduced for ACK/NACK transmission, it may be applicable only for 15 kHz subcarrier spacing. When the new format is applicable only for 15 kHz subcarrier spacing, it may support both single-tone and multi-tone ACK/NACK transmission. Single tone ACK/NACK transmission may be assumed to be one type of multi-tone ACK/NACK transmission.
- [121] Alternatively, only single-tone ACK/NACK transmission may be supported and the single-tone ACK/NACK transmission may support 3.75 kHz and 15 kHz carrier spacing. Single-tone transmission and multi-tone ACK/NACK transmission may also be separated by the number of bits carried in ACK/NACK transmission. If ACK/NACK bundling/aggregation is used, more than one bit ACK/NACK may need to be delivered. In this case, a new channel may be used for multi-tone ACK/NACK transmission, whereas single-tone ACK/NACK transmission may be used if ACK/

NACK bit is 1 bit.

- [122] When multi-tone ACK/NACK transmission is used, one bit may be mapped to one tone, and the number of tones required for ACK/NACK transmission may be linearly increased with the number of bits to be transmitted.
- [123] Alternatively, a new format may be used for single-tone ACK/NACK transmission and PUCCH format 3 may be used for multi-tone ACK/NACK transmission. When multi-tone ACK/NACK transmission with multiple bits is used, the same format may also be used for transmission of other uplink control information (UCI), such as feedback or other UL control information.
- [124] Hereinafter, various aspects of ACK/NACK transmission according to an embodiment of the present invention is described.
- [125] In smart meter or some IoT applications, it is expected that UL traffic frequently occurs compared to DL traffic. In that sense, it may be inefficient to reserve some resource for ACK/NACK transmission corresponding to DL traffic. Overall, it may be more efficient that transmission of ACK/NACK via data channel such as PUSCH. However, some clarification in terms of resource unit and transmission mechanisms may be needed.
- [126] (1) For frequency/time resource selection of ACK/NACK transmission, frequency resource of ACK/NACK transmission may be prefixed, and time resource of ACK/NACK transmission may be implicitly selected. Frequency resource may be selected at the edge of 180 kHz (i.e. edge subcarrier(s)). Whether to use one or more subcarriers during one ACK/NACK transmission may be dependent on frequency hopping used in ACK/NACK transmission. If this approach is used, one subcarrier from the edge may be reserved for ACK/NACK transmission which can be also used for transmitting PUSCH if scheduled.
- [127] Frequency resource of ACK/NACK transmission determination is described in detail. To determine the starting location of frequency resource with frequency offset, overall two approaches may be considered. First approach is to determine implicitly based on e.g. CCE index or PDSCH transmission location in terms of time (e.g., starting subframe). The other approach is to fix the baseline starting offset. The first approach may complicate the scheduling, as the starting frequency location may change depending on the scheduling. It may also complicate multiplexing of different ACK/NACK transmissions which are scheduled in different times. To simplify the design, fixing the starting frequency offset may be preferred. Considering some cases where the network may schedule ACK/NACK resource for both 15 kHz and 3.75 kHz subcarrier spacing in the same subframes, the starting frequency subcarrier for 15 kHz may be 0 (i.e., the first subcarrier in the NB-IoT carrier) and the starting frequency subcarrier for 3.75 kHz may be 47 (i.e., the last subcarrier in the NB-IoT carrier), such

that ACK/NACK resources for different subcarrier spacing may be separated in frequency domain.

- [128] 3 bits may be considered for ACK/NACK frequency offset. For 15 kHz subcarrier spacing, the starting subcarrier index for ACK/NACK transmission may be fixed as 0, and offset values may be {0, 1, 2, 3, 4, 5, 6, 7}. For 3.75 kHz subcarrier spacing, the starting subcarrier index for ACK/NACK transmission may be fixed as 47 (i.e. the last subcarrier in a PRB), and offset values may be {0, -1, -2, -3, -4, -5, -6, -7}.
- [129] Time resource of ACK/NACK transmission determination is described in detail. It may be good if some alignment among different ACK/NACK transmissions can be achieved. To align among different ACK/NACK transmissions, the two approaches may be considered.
- [130] FIG. 16 shows an example of ACK/NACK alignments in resource unit according to an embodiment of the present invention. That is, in this embodiment, ACK/NACK transmissions may be aligned in multiple of resource unit sizes (e.g. aligned with resource unit of single tone transmission). The offset value may be dynamically indicated which can be computed as multiple of offset value and the resource unit size of ACK/NACK transmission (2ms for 15 kHz and 8ms for 3.75 kHz). The baseline timing may start from the ending subframe of the corresponding PDSCH and 12ms of processing time may be added. Offset values may be {0, 1, 2, 3} ms, which may be represented as {0, 2, 4, 6} ms for 15 kHz subcarrier spacing and {0, 4, 8, 12} ms for 3.75 kHz subcarrier spacing.
- [131] FIG. 17 shows an example of ACK/NACK alignments among different PDSCH transmissions according to an embodiment of the present invention. In this embodiment, the offset value may be dynamically indicated which can be computed as multiple of offset value and the repetition number of the corresponding narrowband PDSCH (NB-PDSCH). The offset values may be {-1, 0, 1, 2} which can be represented as $\{1/2 * R, 0, R, 2 * R\}$ where R is the number of the corresponding NB-PDSCH. To simplify, instead of R, R_{max} may also be used.
- [132] Generally, ACK/NACK transmission is much shorter than NB-PDSCH repetition transmission. Thus, it is not necessarily to align among different PDSCHs for ACK/NACK transmission, which can also delay the ACK/NACK transmission and thus reduce the overall throughput. In this sense, embodiment of FIG. 16 may be preferred. Accordingly, time offset of ACK/NACK transmission time resource may be dynamically indicated in DL grant. 2 bits may be used for ACK/NACK time offset value. A UE may transmit ACK/NACK at subframe $n + 12 + K(i)$ where n is the end of the corresponding PDSCH transmission, and $K(i) =$ the offset value indicated by DL grant * resource unit size in time.
- [133] Alternatively, semi-statically configured resource may be used. That is, semi-

statically configured ACK/NACK transmission resource may be scheduled. For semi-static configuration, similar to semi-persistent scheduling (SPS), periodicity and resource may be configured. Different from PUSCH SPS, modulation and coding scheme (MCS) configuration may not be necessary. Also, if semi-static configuration of time resource of ACK/NACK transmission within one PUSCH resource unit is used, the starting offset or sub-ACK/NACK resource unit index may be indicated by SPS ACK/NACK configuration.

- [134] Alternatively, frequency/time resource of ACK/NACK transmission may be determined implicitly. Similar to mechanisms used for determining timer resource based on control and/or data channel resource, scheduling data channel may be used to determine frequency/time resource of ACK/NACK transmission. Or, UE-ID and/or some resource for control/data channel scheduling may be used.
- [135] Alternatively, higher layer configuration may be used. A set of frequency/time resource of ACK/NACK transmission may be configured by higher layer. The set size may be 1. If more than one set is configured, the selection of time/frequency resource may be dependent on the resource used for control/data transmission. The set of frequency/time resource may be configured by cell-specific configuration. In this case, an implicit mechanism or some other mechanism may also be used in addition to the configuration.
- [136] Overall, one or more mechanisms described above may be jointly used to select time/frequency resource of ACK/NACK transmission.
- [137] (2) Further, dynamic scheduling of ACK/NACK transmission may be considered. As the frequency resource of ACK/NACK transmission is low, the resource used for ACK/NACK transmission may be dynamically indicated. For dynamic scheduling of ACK/NACK transmission, the frequency/time resources of ACK/NACK transmission may be scheduled in DCI. The frequency/time resources of ACK/NACK transmission may be piggybacked with DL grant or may be indicated by separate DCI. Or, frequency resource of ACK/NACK transmission may be scheduled in DCI, whereas time resource of ACK/NACK transmission may be determined as the above rule for frequency/time resource selection of ACK/NACK transmission. Or, activation of ACK/NACK transmission may be triggered by DCI. If activation is not triggered, ACK/NACK transmission may not be attempted and the resource of ACK/NACK transmission may be semi-statically configured or predetermined according to the rule of resource selection. Or, if immediate ACK/NACK transmission is supported, one bit either triggering immediate ACK/NACK or indicating piggyback with the next PUSCH may be indicated. In this case, ACK/NACK may be transmitted and the resource may be selected based on the above mentioned rule(s). If next PUSCH piggyback is triggered, ACK/NACK transmission may be piggybacked with the next

PUSCH transmission opportunity.

- [138] (3) Further, simultaneous transmission of ACK/NACK and PUSCH may be considered. ACK/NACK transmission may be overlapped with PUSCH transmission. In this case, ACK/NACK transmission may be piggybacked with PUSCH transmission. Or, ACK/NACK transmission may be separately performed. Or, either ACK/NACK transmission or PUSCH transmission may be dropped.
- [139] For ACK/NACK piggyback, ACK/NACK bit may be added as the most significant bit in the payload. ACK/NACK bit may be encoded with the data transmission and transmitted jointly with PUSCH transmission. Or, ACK/NACK bit may be embedded in DM-RS sequence during PUSCH transmission. Depending on ACK or NACK, the DM-RS sequence may be changed. For example, cyclic shift-like time varying parameter may be selected or changed for case of only PUSCH, ACK with PUSCH, and NACK with PUSCH. Or, ACK/NACK bit may be embedded in CDM code across PUSCH transmission. CDM code may be selected differently based on only PUSCH or ACK with PUSCH or NACK with PUSCH. Meanwhile, when ACK/NACK transmission is piggybacked with PUSCH transmission, only ACK may be transmitted. In case of NACK transmission, only PUSCH may be transmitted (i.e. no NACK piggyback transmission).
- [140] For separate ACK/NACK and PUSCH transmission, since sub-ACK/NACK resource unit(s) occurs discontinuously, a UE may transmit ACK/NACK in the sub-ACK/NACK resource unit(s), and PUSCH in other resource units. Considering ACK/NACK resource consumption, the network may configure sufficient large number of repetitions. In other words, resources used for ACK/NACK transmission may be counted for PUSCH repetition.
- [141] For dropping either ACK/NACK transmission or PUSCH transmission, if ACK/NACK is NACK, ACK/NACK transmission may be dropped. Otherwise, PUSCH transmission may be dropped. Or, regardless of ACK/NACK status, either PUSCH transmission or ACK/NACK transmission may always be dropped. Based on configured/predefined priority rule, either ACK/NACK transmission or PUSCH transmission may be dropped.
- [142] Or, different DM-RS sequence (root sequence or cyclic shift) and/or scrambling code may be used to embed positive ACK. For NACK, the same sequence and/or scrambling code without ACK/NACK piggyback may be used, and for ACK, different sequence and/or scrambling code may be used.
- [143] (4) Meanwhile, the present invention mainly discusses ACK/NACK transmission, similar mechanisms may be used for CSI feedback. Particularly, when asynchronous CSI feedback is triggered, handling simultaneous transmission of ACK/NACK with PUSCH may be applicable to CSI feedback as well. More generally, if a PUSCH

resource unit is defined as M subframes, 'K' subframes in the middle may be assumed to transmit UCI (e.g. ACK/NACK or CSI). Whenever PUSCH repetition occurs, K subframes may be repeated as well to transmit repeated UCI.

- [144] For scheduling request (SR) trigger, in addition to transmission of SR via RACH procedure, SR may be triggered by DL grant or UL grant. If the grant includes SR trigger, the UE may transmit positive or negative SR (similar to ACK/NACK transmission). For resource determination of positive/negative SR transmission, similar mechanism to ACK/NACK resource determination may be used. In case of piggyback with PUSCH, SR may be ignored when UL grant triggers SR and the UE has data to transmit. One approach to transmit SR may be to use Q term in BPSK modulation to carry SR, whereas ACK/NACK may be carried over I term BPSK modulation. Even in this case, if there is no ACK/NACK transmission, SR alone may not be triggered.
- [145] (5) Further, ACK/NACK transmission via RACH procedure or format may be considered. To minimize PAPR, single tone transmission may be used for physical random access channel (PRACH) transmission. If RACH channel with single tone is introduced, the same channel may also be used for ACK/NACK transmission. For example, DM-RS may be transmitted continuously over multiple symbols for PRACH with single tone. In this case, different code may be used to multiplex multiple UEs. When ACK/NACK is carried over PRACH format, the code may be selected based on ACK or NACK per each UE. The set of codes usable by one UE may be higher layer configured or determined based on the time resource selection rule mentioned above. However, ACK/NACK transmission may not require long preamble, thus, this may be used only for SR transmission with ACK/NACK transmission. Or, different CP or preamble length between RACH transmission and ACK/NACK transmission may be used with the same physical channel format. Alternatively, a very small PRACH format (i.e. low overhead PRACH) may be defined which can be used for PDCCH order triggered PRACH and/or ACK/NACK transmission.
- [146] (6) Further, power control of ACK/NACK transmission or PUSCH transmission may be considered. As one resource unit for PUSCH transmission and/or one sub-ACK/NACK resource unit for ACK/NACK transmission is used and multiple UEs with different coverage level may be multiplexed, it is essential to perform power control per resource unit or sub-ACK/NACK resource unit level. For this, at least one of the following options may be considered.
- [147] - (PC_{max, c} - Delta) may be set per each coverage level, and Delta may be determined per coverage level. Or, Delta may be determined by {coverage level minimum reference signal received power (RSRP) - higher layer filtered RSRP}. In other words, only UEs in the same coverage classes may be multiplexed in the same resource, the power may be reduced to UEs with better coverage but belonging to the

- same coverage level. Or, delta may be higher layer configured per each UE via Msg 3 UL grant or via RRC signaling.
- [148] - Existing power control mechanism may be used where the basic resource unit becomes different (e.g. single tone with 12 subframes). If multi-tones are scheduled, similar to multiple PRB case, the power assignment may be increased. The initial parameters and some parameters may be customized to be fitted with single tone transmission.
- [149] - PCmax, c may always be used. That is, regardless of the required number of repetition, PCmax, c may always be used.
- [150] - Power may be decreased if the required number of repetitions is less than the size of one resource unit or one sub-ACK/NACK resource unit. For example, if very small TB is scheduled, in a good coverage, a UE may not require so many repetitions up to the size of one resource size. In this case, to transmit over the entire one resource block, the power may be reduced accordingly. Or, the number of subframes to be transmitted may be reduced. In other words, sub-ACK/NACK resource unit transmission may be allowed even in PUSCH case.
- [151] - The configured power in UL grant may be used.
- [152] - the semi-statically configured power may be used.
- [153] Transmit power command (TPC) may not be used via UL grant. However, TPC command such as via cell-specific search space (CSS) - DCI 3/3A format, may be still used.
- [154] FIG. 18 shows a method for transmitting an ACK/NACK by a NB-IoT UE according to an embodiment of the present invention. The embodiments of the present invention described above may be applied to this embodiment of the present invention.
- [155] In step S100, the NB-IoT UE receives an indication of resources for ACK/NACK transmission from a network. In step S110, the NB-IoT UE transmits the ACK/NACK to the network by using the resource for ACK/NACK transmission.
- [156] The indication may be received by DCI. The DCI may be a DL grant or a separate DCI. Further, the DCI may include an activation of the ACK/NACK transmission.
- [157] The resources for ACK/NACK transmission may include at least one of a frequency resource for ACK/NACK transmission or a time resource for ACK/NACK transmission. The frequency resource for ACK/NACK transmission may be prefixed. The frequency resource for ACK/NACK transmission may be prefixed as at edge subcarrier of 180 kHz bandwidth. Or, the resources for ACK/NACK transmission may be configured semi-statically. Or, the resources for ACK/NACK transmission may be determined based on resources of a control channel or a data channel. Or, the resources for ACK/NACK transmission is configured by higher-layer signaling.
- [158] The ACK/NACK may be transmitted immediately or transmitted by being pig-

gybacked with a next PUSCH transmission. For this, an indication of whether the immediate ACK/NACK transmission or the piggybacked ACK/NACK transmission is performed may be received from the network.

[159] FIG. 19 shows a wireless communication system to implement an embodiment of the present invention.

[160] An eNB 800 includes a processor 810, a memory 820 and a transceiver 830. The processor 810 may be configured to implement proposed functions, procedures and/or methods described in this description. Layers of the radio interface protocol may be implemented in the processor 810. The memory 820 is operatively coupled with the processor 810 and stores a variety of information to operate the processor 810. The transceiver 830 is operatively coupled with the processor 810, and transmits and/or receives a radio signal.

[161] A UE 900 includes a processor 910, a memory 920 and a transceiver 930. The processor 910 may be configured to implement proposed functions, procedures and/or methods described in this description. Layers of the radio interface protocol may be implemented in the processor 910. The memory 920 is operatively coupled with the processor 910 and stores a variety of information to operate the processor 910. The transceiver 930 is operatively coupled with the processor 910, and transmits and/or receives a radio signal.

[162] The processors 810, 910 may include application-specific integrated circuit (ASIC), other chipset, logic circuit and/or data processing device. The memories 820, 920 may include read-only memory (ROM), random access memory (RAM), flash memory, memory card, storage medium and/or other storage device. The transceivers 830, 930 may include baseband circuitry to process radio frequency signals. When the embodiments are implemented in software, the techniques described herein can be implemented with modules (e.g., procedures, functions, and so on) that perform the functions described herein. The modules can be stored in memories 820, 920 and executed by processors 810, 910. The memories 820, 920 can be implemented within the processors 810, 910 or external to the processors 810, 910 in which case those can be communicatively coupled to the processors 810, 910 via various means as is known in the art.

[163] In view of the exemplary systems described herein, methodologies that may be implemented in accordance with the disclosed subject matter have been described with reference to several flow diagrams. While for purposed of simplicity, the methodologies are shown and described as a series of steps or blocks, it is to be understood and appreciated that the claimed subject matter is not limited by the order of the steps or blocks, as some steps may occur in different orders or concurrently with other steps from what is depicted and described herein. Moreover, one skilled in the art

would understand that the steps illustrated in the flow diagram are not exclusive and other steps may be included or one or more of the steps in the example flow diagram may be deleted without affecting the scope and spirit of the present disclosure.

Claims

- [Claim 1] A method for transmitting an acknowledgement/non-acknowledgment (ACK/NACK) by a narrowband internet-of-things (NB-IoT) user equipment (UE) in a wireless communication system, the method comprising:
receiving an indication of resources for ACK/NACK transmission from a network; and
transmitting the ACK/NACK to the network by using the resource for ACK/NACK transmission.
- [Claim 2] The method of claim 1, wherein the indication is received by downlink control information (DCI).
- [Claim 3] The method of claim 2, wherein the DCI is a DL grant or a separate DCI.
- [Claim 4] The method of claim 2, wherein the DCI includes an activation of the ACK/NACK transmission.
- [Claim 5] The method of claim 1, wherein the resources for ACK/NACK transmission includes at least one of a frequency resource for ACK/NACK transmission or a time resource for ACK/NACK transmission.
- [Claim 6] The method of claim 5, wherein the frequency resource for ACK/NACK transmission is prefixed.
- [Claim 7] The method of claim 6, wherein the frequency resource for ACK/NACK transmission is prefixed as at edge subcarrier of 180 kHz bandwidth.
- [Claim 8] The method of claim 1, wherein the resources for ACK/NACK transmission is configured semi-statically.
- [Claim 9] The method of claim 1, wherein the resources for ACK/NACK transmission is determined based on resources of a control channel or a data channel.
- [Claim 10] The method of claim 1, wherein the resources for ACK/NACK transmission is configured by higher-layer signaling.
- [Claim 11] The method of claim 1, wherein the ACK/NACK is transmitted immediately or transmitted by being piggybacked with a next physical uplink shared channel (PUSCH) transmission.
- [Claim 12] The method of claim 1, wherein an indication of whether the immediate ACK/NACK transmission or the piggybacked ACK/NACK transmission is performed is received from the network.
- [Claim 13] A narrowband internet-of-things (NB-IoT) user equipment (UE) in a

wireless communication system, the NB-IoT UE comprising:
a memory;
a transceiver; and
a processor, coupled to the memory and the transceiver, that:
controls the transceiver to receive an indication of resources for an acknowledgement/non-acknowledgement (ACK/NACK) transmission from a network, and
controls the transceiver to transmit an ACK/NACK to the network by using the resource for ACK/NACK transmission.

[Fig. 1]

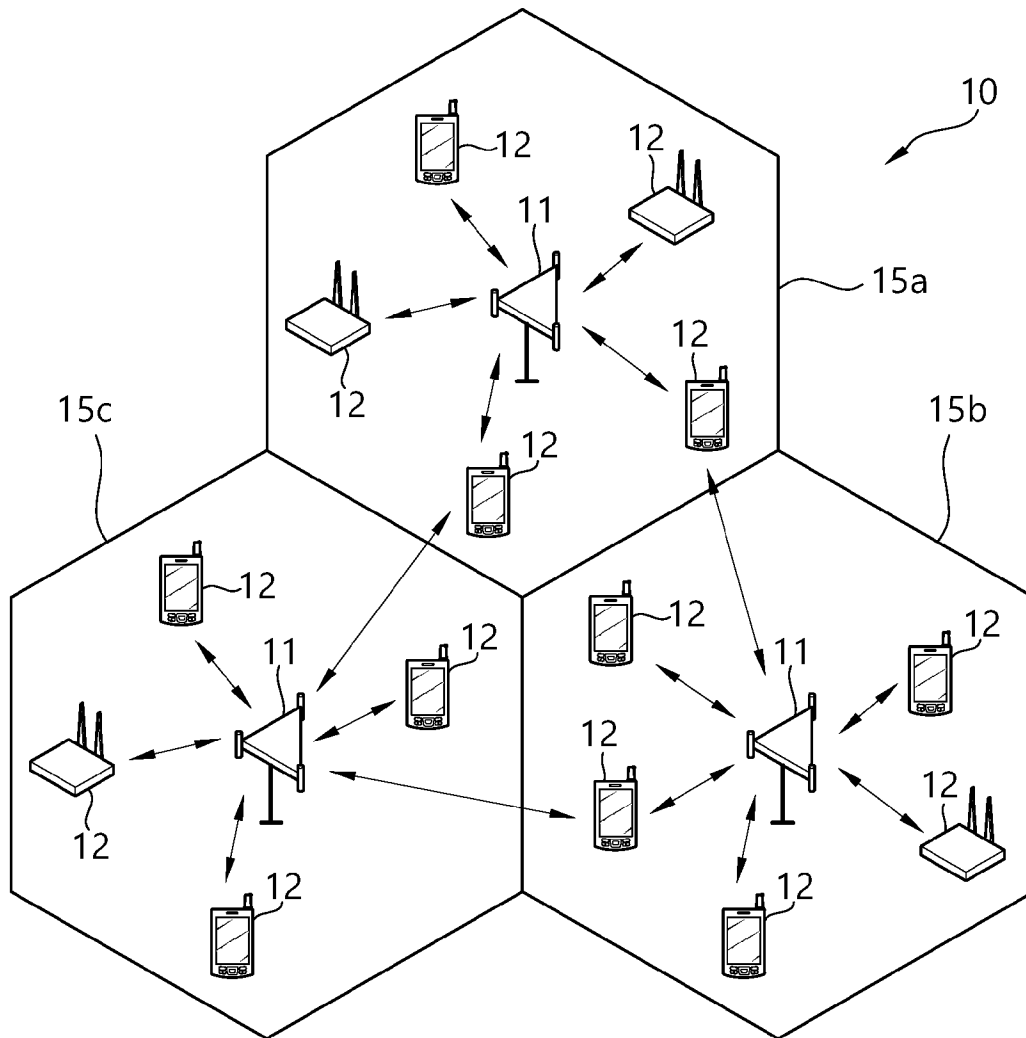

[Fig. 2]

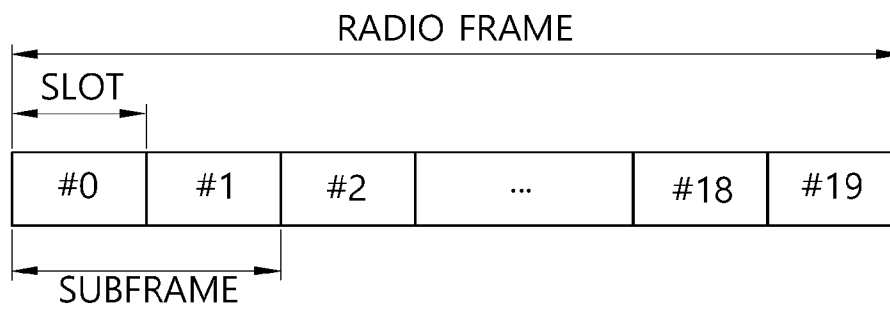

[Fig. 3]

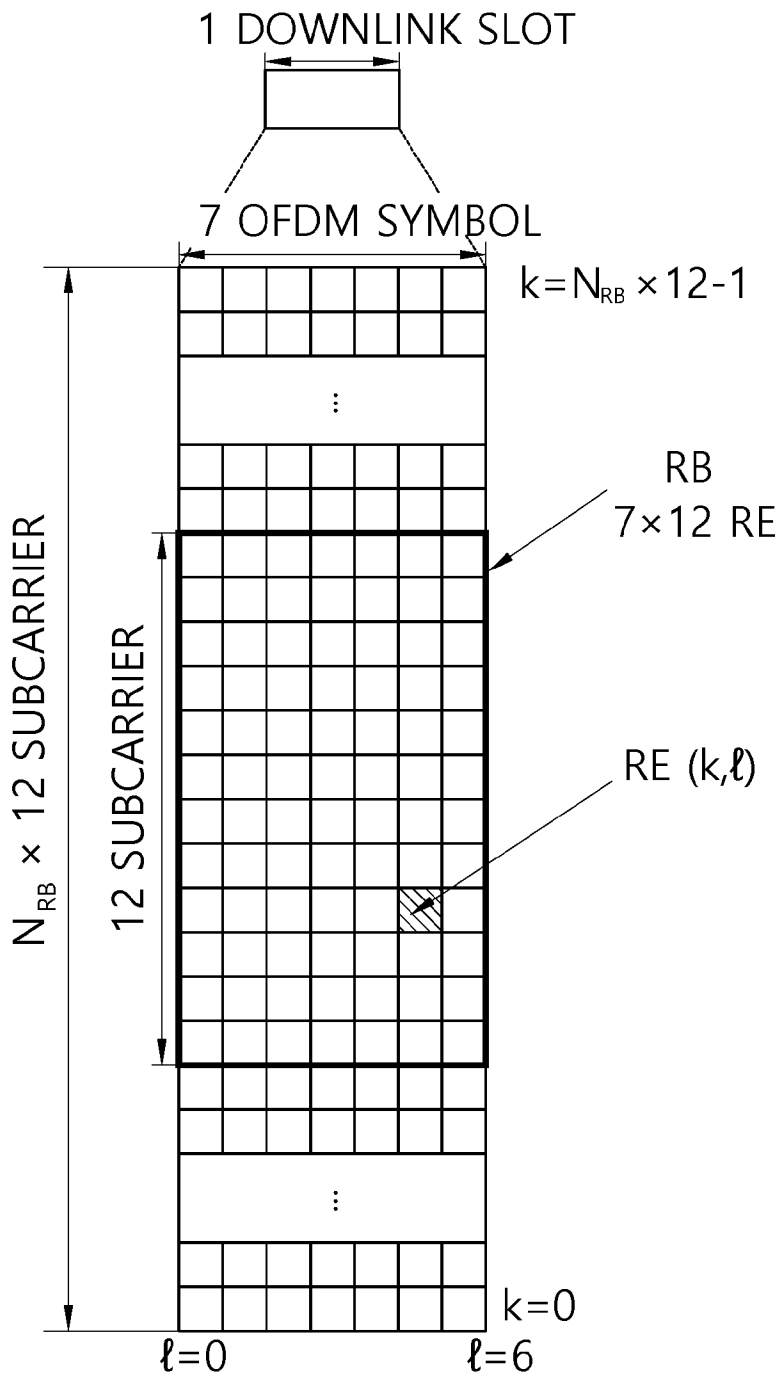

[Fig. 4]

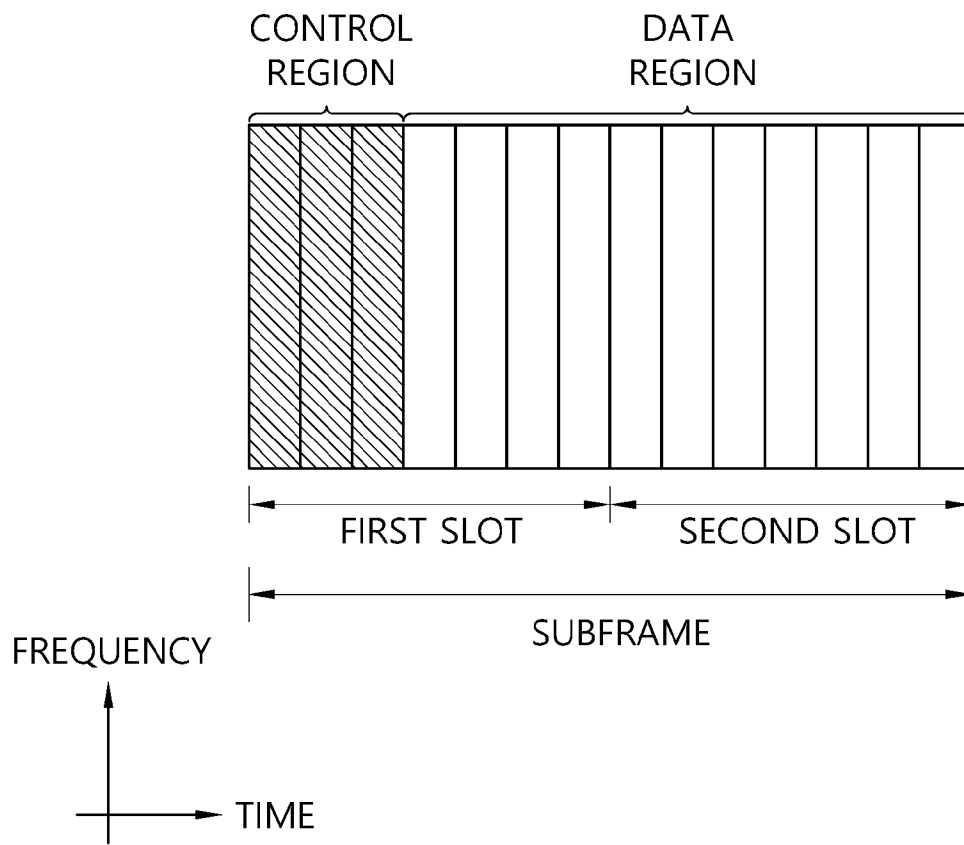

[Fig. 5]

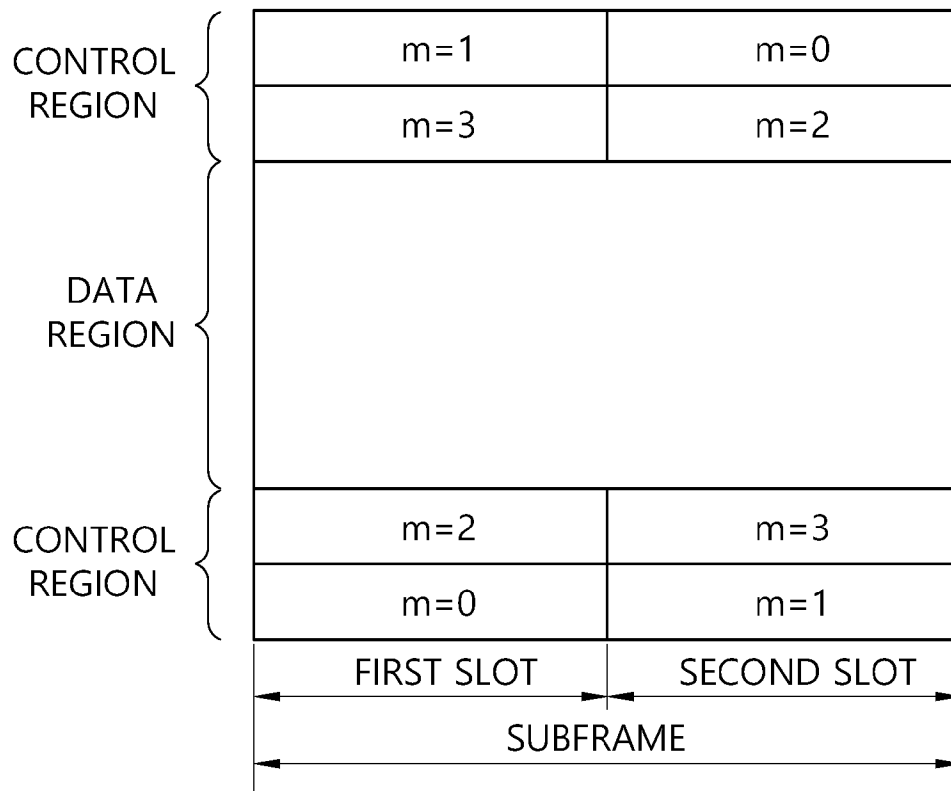

FREQUENCY

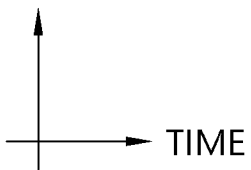

[Fig. 6]

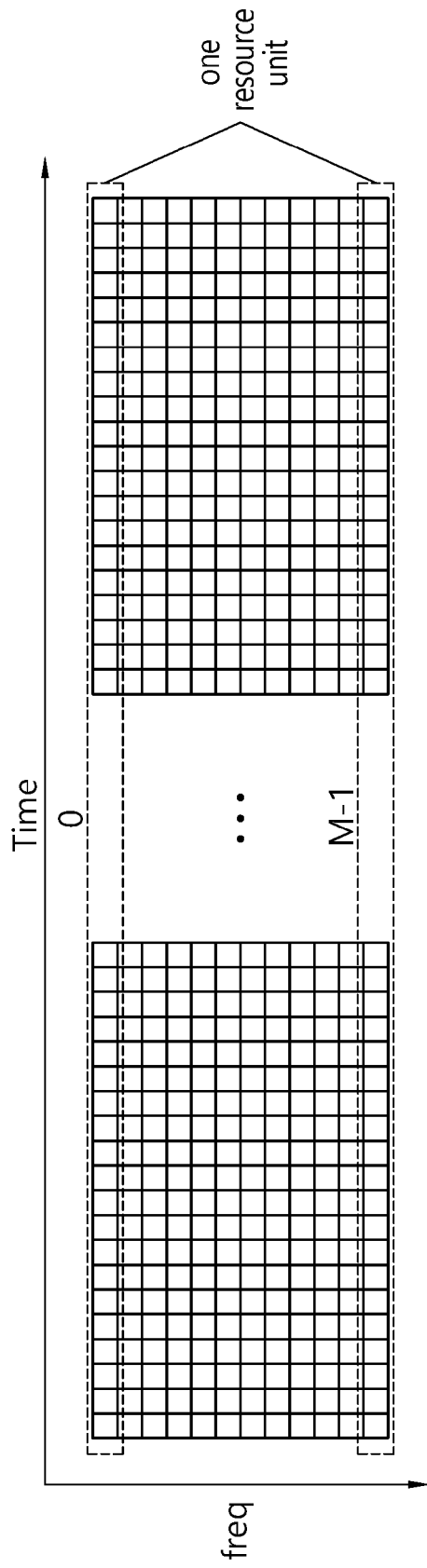

[Fig. 7]

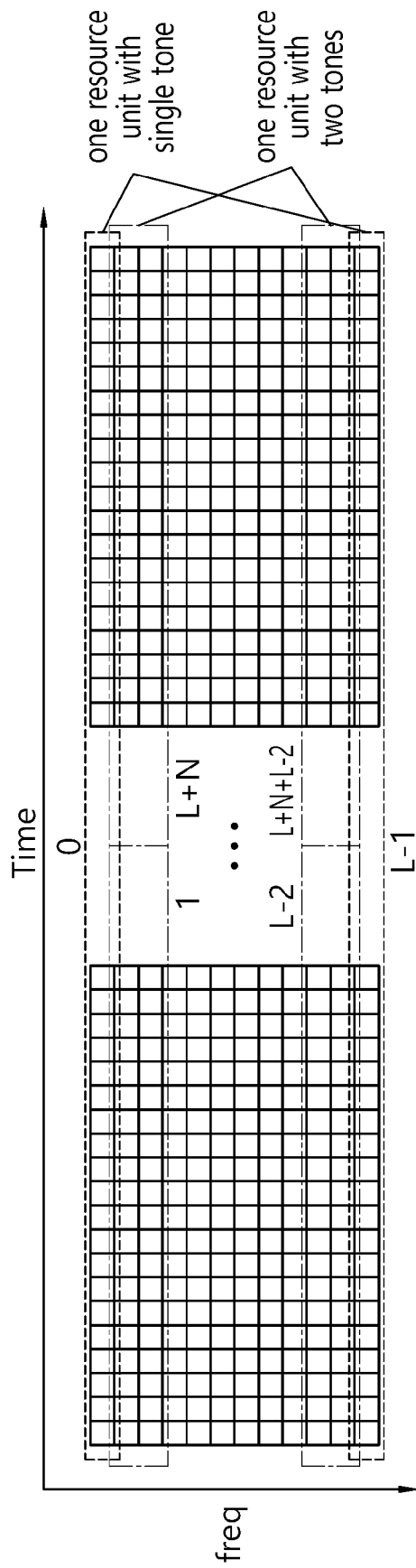

[Fig. 8]

0				10				
1		6		11		16		
2	5	7	9	12	15	17	19	...
3		8		13		18		
4				14				

[Fig. 10]

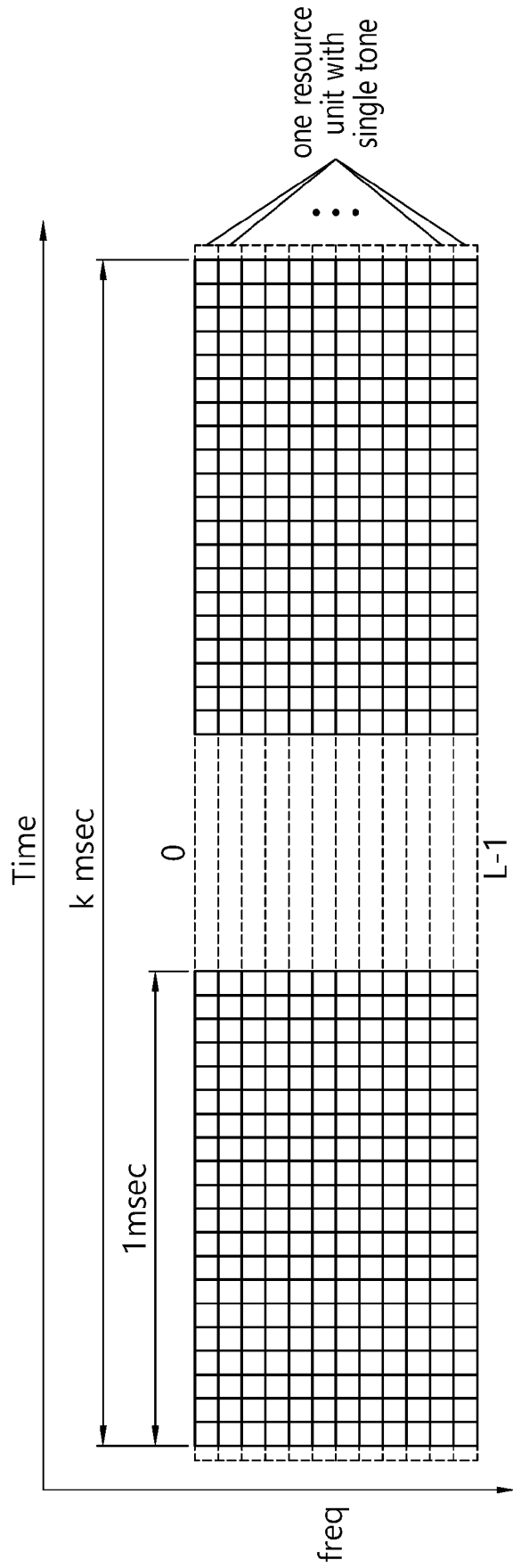

[Fig. 11]

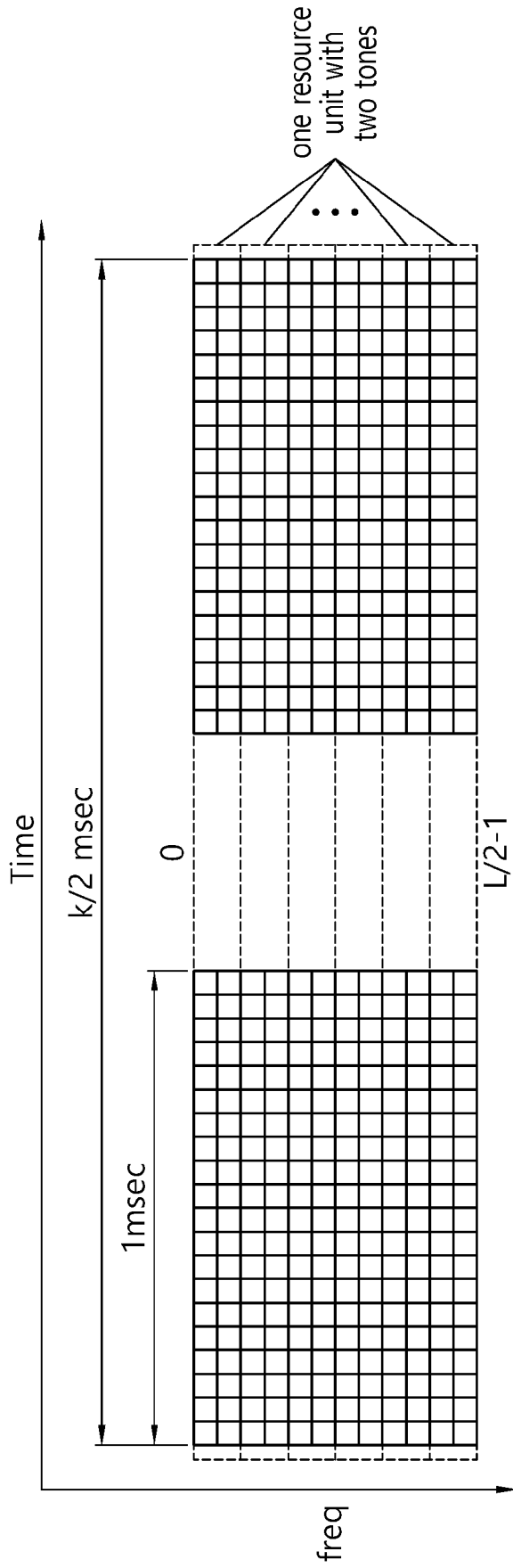

[Fig. 12]

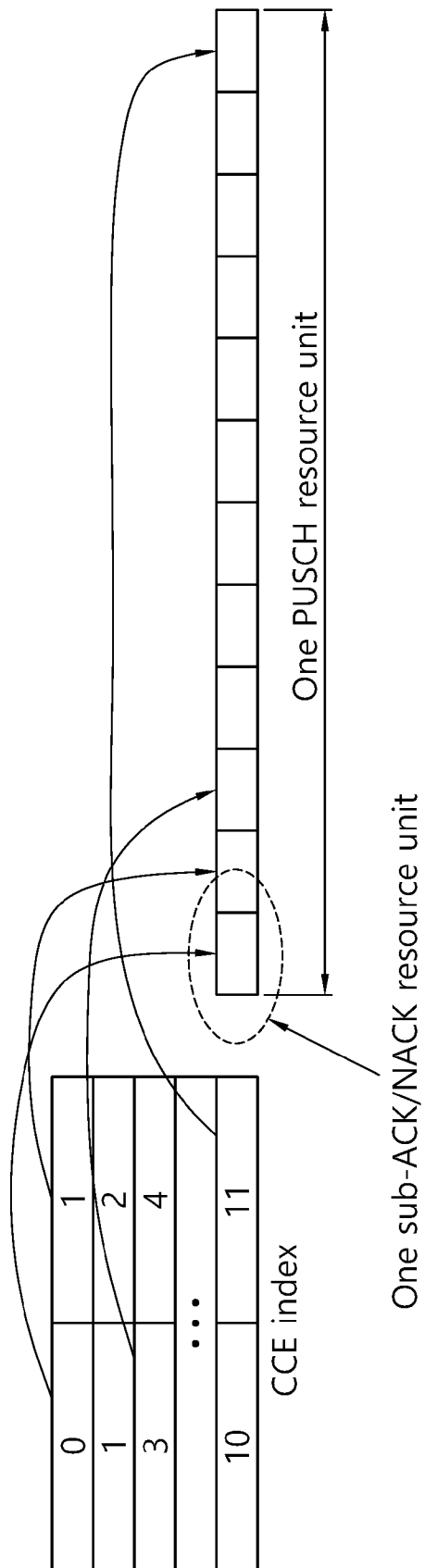

[Fig. 13]

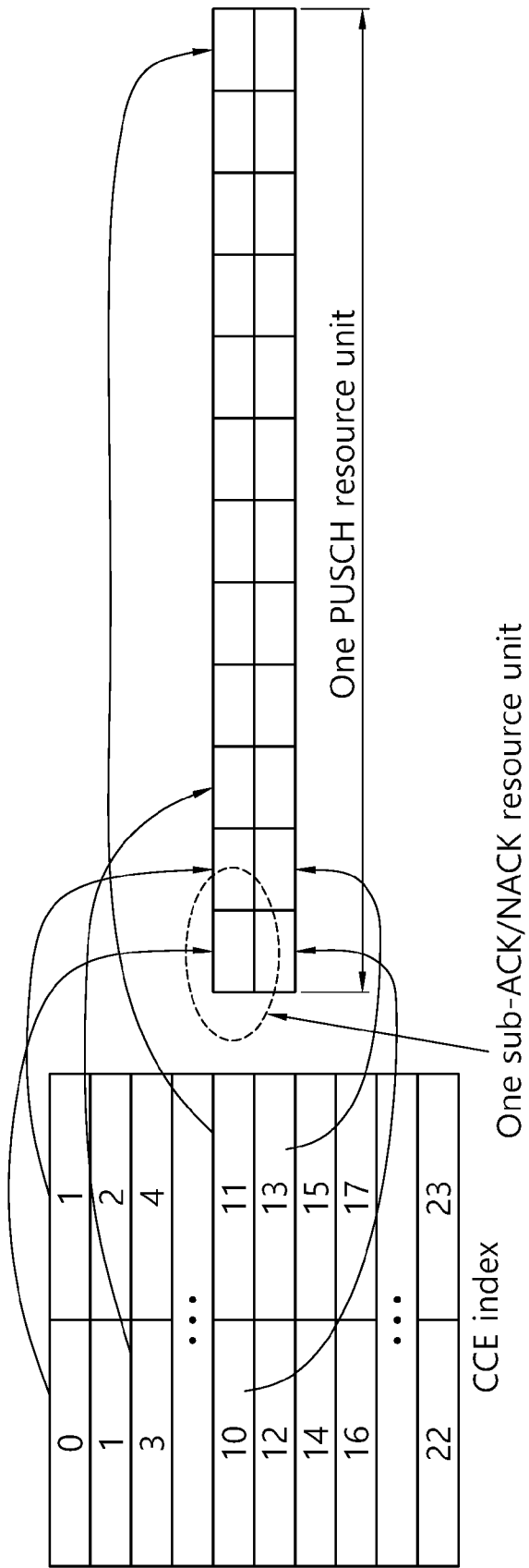

[Fig. 14]

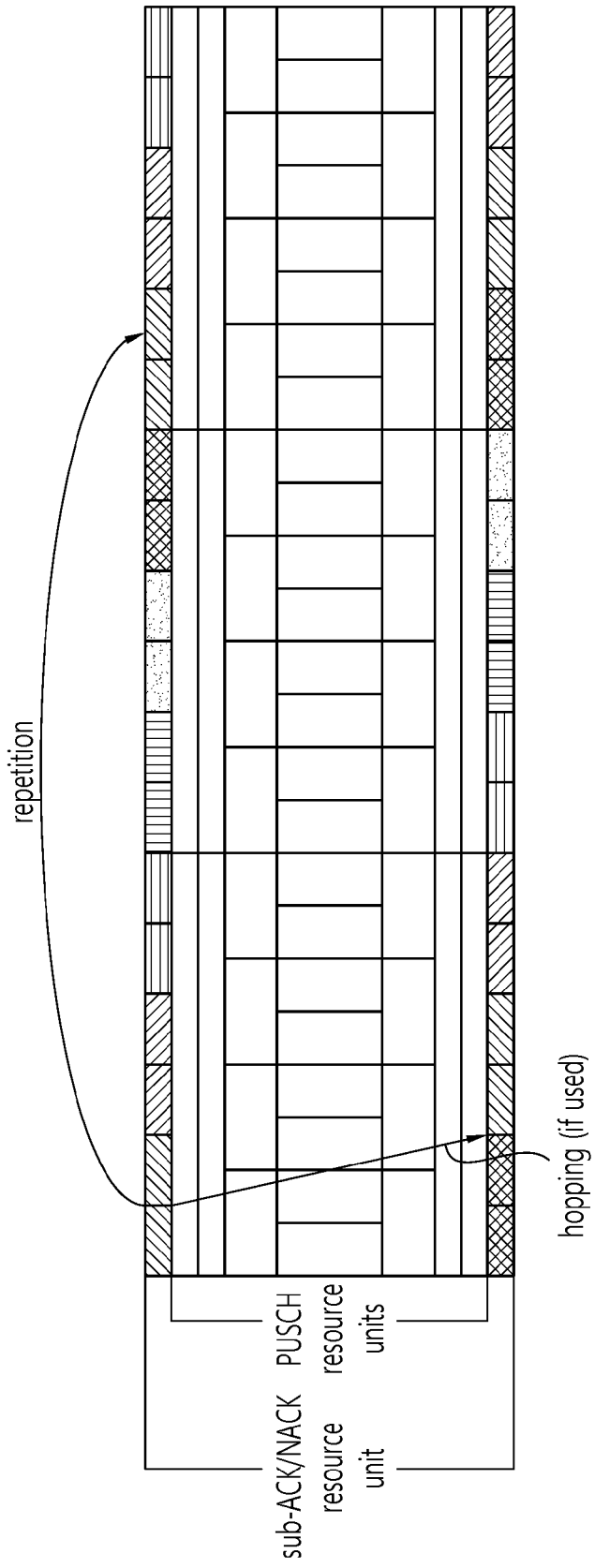

[Fig. 15]

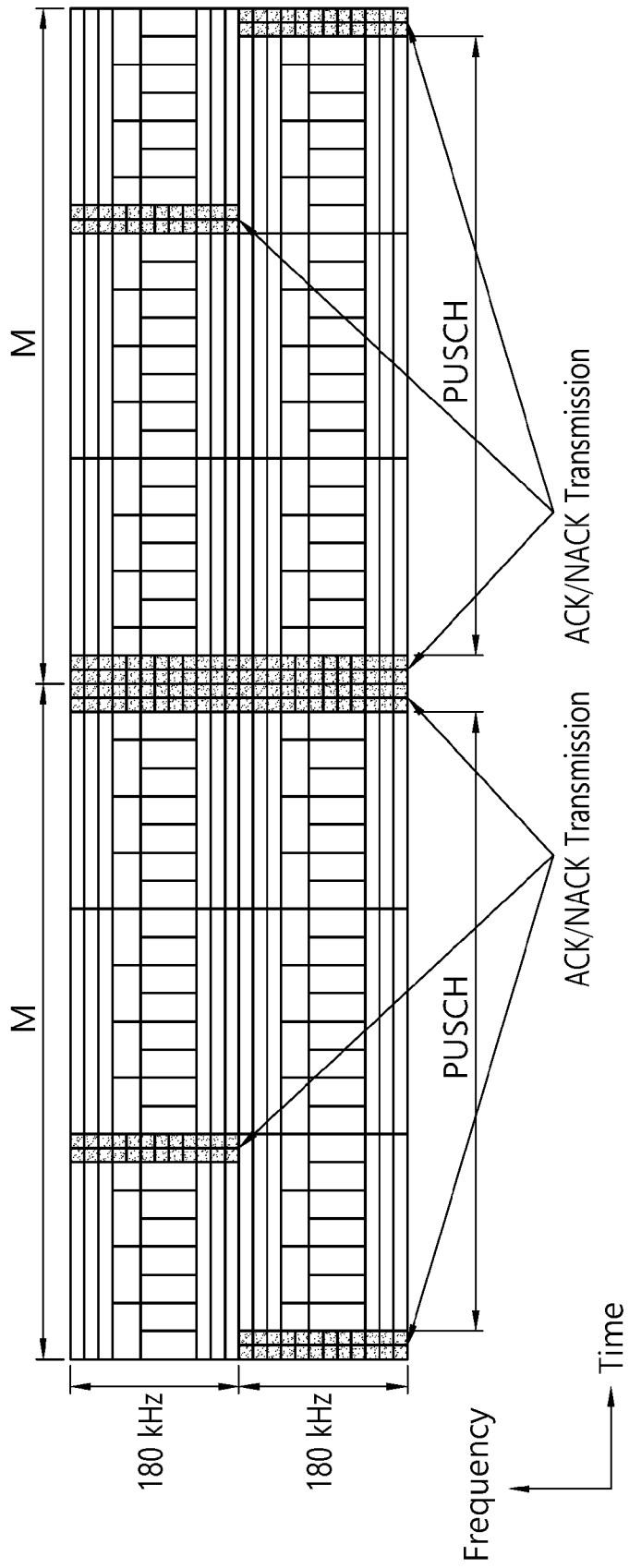

[Fig. 16]

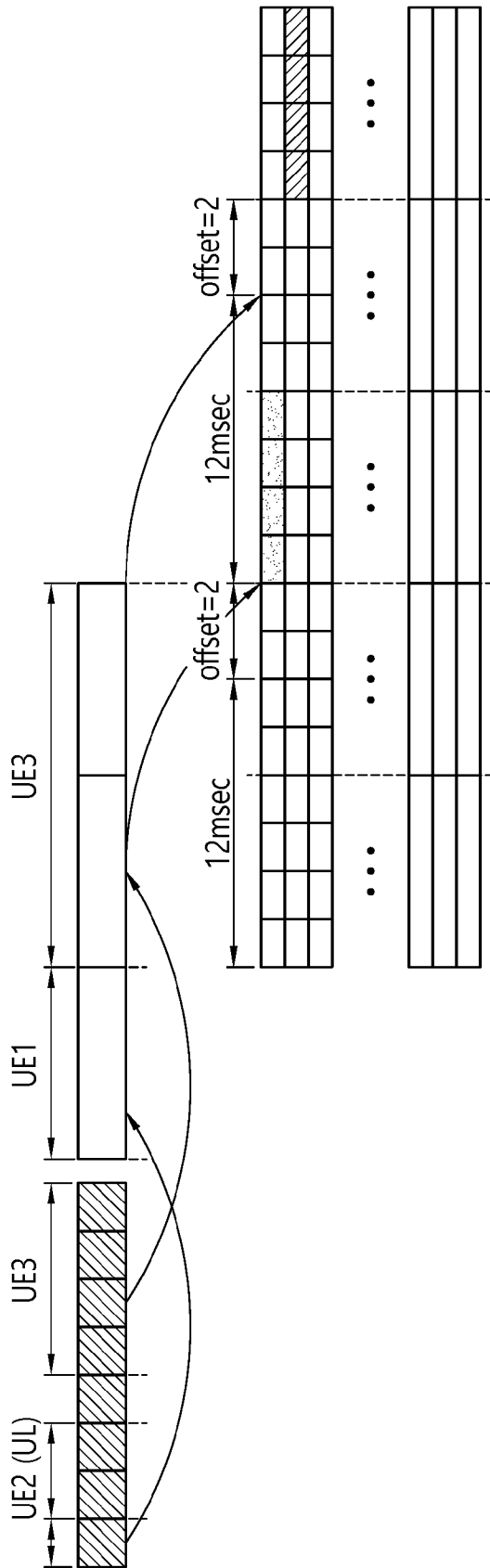

[Fig. 17]

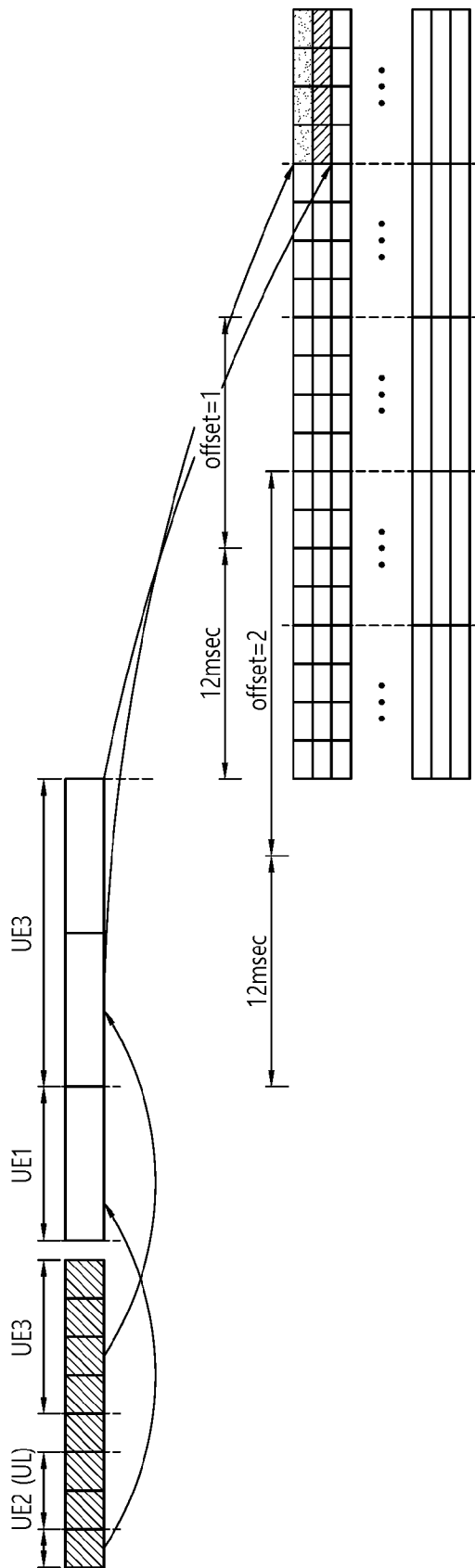

[Fig. 18]

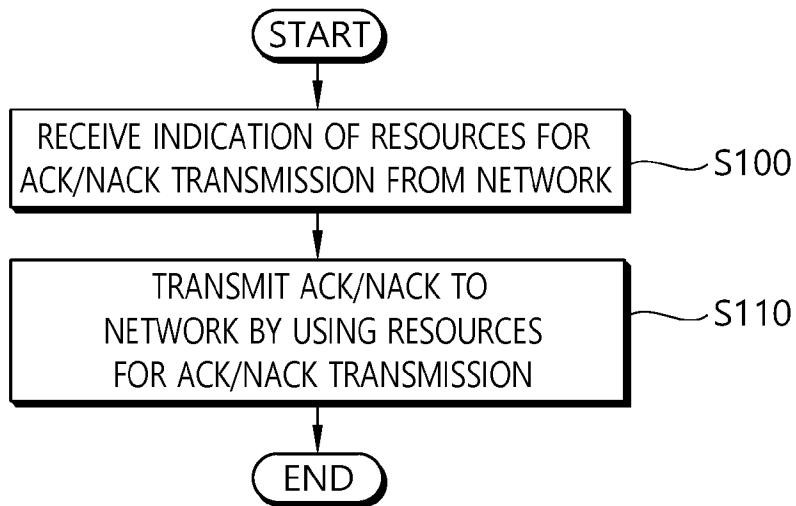

[Fig. 19]

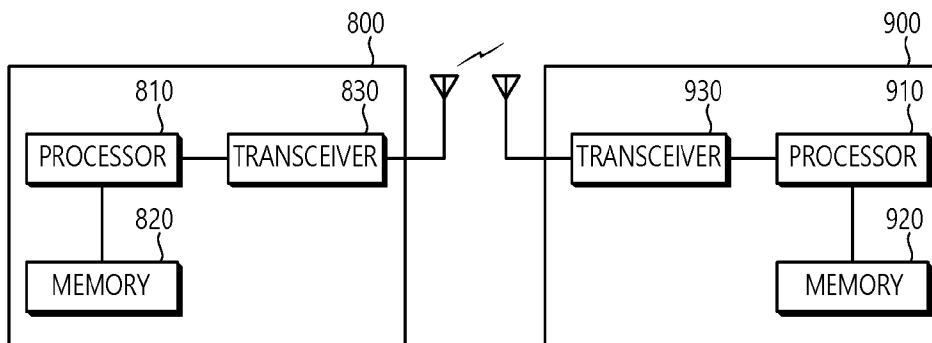

INTERNATIONAL SEARCH REPORT

International application No.
PCT/KR2016/015346**A. CLASSIFICATION OF SUBJECT MATTER****H04L 5/00(2006.01)i, H04W 72/04(2009.01)i**

According to International Patent Classification (IPC) or to both national classification and IPC

B. FIELDS SEARCHEDMinimum documentation searched (classification system followed by classification symbols)
H04L 5/00; H04W 72/04Documentation searched other than minimum documentation to the extent that such documents are included in the fields searched
Korean utility models and applications for utility models
Japanese utility models and applications for utility modelsElectronic data base consulted during the international search (name of data base and, where practicable, search terms used)
eKOMPASS(KIPO internal) & keywords: NB-IoT, ACK/NACK, resource, DCI(downlink control information)**C. DOCUMENTS CONSIDERED TO BE RELEVANT**

Category*	Citation of document, with indication, where appropriate, of the relevant passages	Relevant to claim No.
X	US 2013-0195065 A1 (DONG HYUN PARK) 01 August 2013 See paragraphs [0022]-[0073]; claims 16-24; and figure 5.	1-6,9,10,13
Y		8,11,12
A		7
Y	WO 2014-110785 A1 (BROADCOM CORPORATION et al.) 24 July 2014 See paragraph [0025]; and figure 3.	8
Y	US 2013-0039321 A1 (MIN GYU KIM et al.) 14 February 2013 See paragraphs [0067]-[0120]; and figure 10.	11,12
A	CMCC, 'On ACK/NACK Feedback for MUST', R1-157005, 3GPP TSG RAN WG1 Meeting #83, 06 November 2015 See section 3.	1-13
A	MEDIATEK INC., 'Resource allocation and DCI format design', R1-154711, 3GPP TSG RAN WG1 Meeting #82, 15 August 2015 See section 2.	1-13

 Further documents are listed in the continuation of Box C. See patent family annex.

* Special categories of cited documents:

"A" document defining the general state of the art which is not considered to be of particular relevance

"E" earlier application or patent but published on or after the international filing date

"L" document which may throw doubts on priority claim(s) or which is cited to establish the publication date of another citation or other special reason (as specified)

"O" document referring to an oral disclosure, use, exhibition or other means

"P" document published prior to the international filing date but later than the priority date claimed

"T" later document published after the international filing date or priority date and not in conflict with the application but cited to understand the principle or theory underlying the invention

"X" document of particular relevance; the claimed invention cannot be considered novel or cannot be considered to involve an inventive step when the document is taken alone

"Y" document of particular relevance; the claimed invention cannot be considered to involve an inventive step when the document is combined with one or more other such documents, such combination being obvious to a person skilled in the art

"&" document member of the same patent family

Date of the actual completion of the international search

27 March 2017 (27.03.2017)

Date of mailing of the international search report

27 March 2017 (27.03.2017)

Name and mailing address of the ISA/KR

International Application Division
Korean Intellectual Property Office
189 Cheongsa-ro, Seo-gu, Daejeon, 35208, Republic of Korea

Facsimile No. +82-42-481-8578

Authorized officer

KANG, Hee Gok

Telephone No. +82-42-481-8264

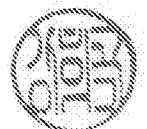

INTERNATIONAL SEARCH REPORT

Information on patent family members

International application No.

PCT/KR2016/015346

Patent document cited in search report	Publication date	Patent family member(s)	Publication date
US 2013-0195065 A1	01/08/2013	CN 103181109 A CN 103181109 B CN 106059719 A EP 2628268 A1 JP 2013-541299 A JP 5766294 B2 KR 10-2012-0039331 A US 2016-0127105 A1 US 9237566 B2 US 9485072 B2 WO 2012-050389 A1	26/06/2013 03/08/2016 26/10/2016 21/08/2013 07/11/2013 19/08/2015 25/04/2012 05/05/2016 12/01/2016 01/11/2016 19/04/2012
WO 2014-110785 A1	24/07/2014	None	
US 2013-0039321 A1	14/02/2013	EP 2562949 A2 US 9210695 B2 WO 2011-132993 A2 WO 2011-132993 A3	27/02/2013 08/12/2015 27/10/2011 08/03/2012