



(86) Date de dépôt PCT/PCT Filing Date: 2013/01/24
 (87) Date publication PCT/PCT Publication Date: 2014/07/31
 (85) Entrée phase nationale/National Entry: 2015/07/16
 (86) N° demande PCT/PCT Application No.: SE 2013/050051
 (87) N° publication PCT/PCT Publication No.: 2014/116150

(51) Cl.Int./Int.Cl. *D21C 11/04* (2006.01),
C07G 1/00 (2011.01)
 (71) Demandeur/Applicant:
VALMET AB, SE
 (72) Inventeur/Inventor:
TIKKA, PANU, FI
 (74) Agent: FETHERSTONHAUGH & CO.

(54) Titre : PROCÉDE DE FABRICATION DE LIGNINE DE HAUTE PURETE
 (54) Title: METHOD FOR PRODUCING HIGH PURITY LIGNIN

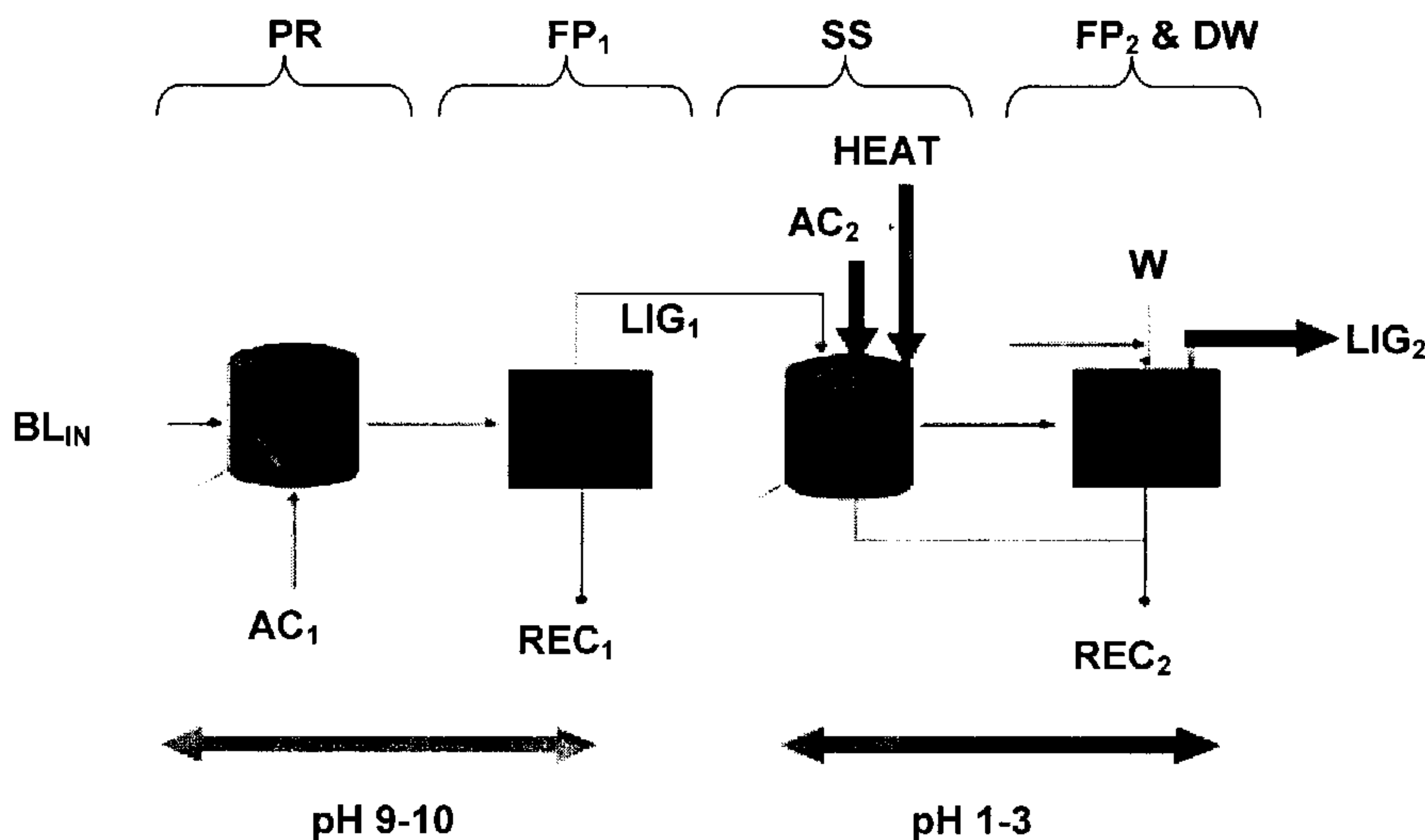

Fig. 4

(57) Abrégé/Abstract:

The present invention relates to a method for separation of lignin from original black liquor (BLIN) comprising a first precipitation stage (PR) for precipitation of lignin by a first acidification using acidifier AC, preferably using CO₂, at alkaline conditions, then

(57) **Abrégé(suite)/Abstract(continued):**

separating a lignin cake with subsequent suspension of the lignin cake in a strong acid in order to leach our metals from the lignin followed by dewatering and obtaining a clean lignin product LP. According to the invention is the process further improved by intensified hydrolysis of lignin cake such that most of the carbohydrates are broken down to dissolvable monomers that could be separated from the lignin in the filtrate from a filtering stage subsequent to the hydrolysis. The improved hydrolysis could reduce as much as 90% of the carbohydrate content using a moderately increased temperature and increased charge of acidifier while avoiding any larger lignin yield losses.

(12) INTERNATIONAL APPLICATION PUBLISHED UNDER THE PATENT COOPERATION TREATY (PCT)

(19) World Intellectual Property
Organization
International Bureau(10) International Publication Number
WO 2014/116150 A1(43) International Publication Date
31 July 2014 (31.07.2014)

- (51) International Patent Classification:
D21C 11/04 (2006.01) *C07G 1/00* (2011.01)
- (21) International Application Number:
PCT/SE2013/050051
- (22) International Filing Date:
24 January 2013 (24.01.2013)
- (25) Filing Language: English
- (26) Publication Language: English
- (71) Applicant: VALMET POWER AB [SE/SE]; Box 8734,
SE-402 75 Göteborg (SE).
- (72) Inventor; and
(71) Applicant : TIKKA, Panu [FI/FI]; Ankarholmsväg 15A,
FI-02160 Esbo (FI).
- (74) Agent: FURHEM, Hans; c/o METSO PAPER SWEDEN
AB, Box 1033, SE-651 15 Karlstad (SE).
- (81) Designated States (*unless otherwise indicated, for every
kind of national protection available*): AE, AG, AL, AM,
AO, AT, AU, AZ, BA, BB, BG, BH, BN, BR, BW, BY,

BZ, CA, CH, CL, CN, CO, CR, CU, CZ, DE, DK, DM,
DO, DZ, EC, EE, EG, ES, FI, GB, GD, GE, GH, GM, GT,
HN, HR, HU, ID, IL, IN, IS, JP, KE, KG, KM, KN, KP,
KR, KZ, LA, LC, LK, LR, LS, LT, LU, LY, MA, MD,
ME, MG, MK, MN, MW, MX, MY, MZ, NA, NG, NI,
NO, NZ, OM, PA, PE, PG, PH, PL, PT, QA, RO, RS, RU,
RW, SC, SD, SE, SG, SK, SL, SM, ST, SV, SY, TH, TJ,
TM, TN, TR, TT, TZ, UA, UG, US, UZ, VC, VN, ZA,
ZM, ZW.

- (84) Designated States (*unless otherwise indicated, for every
kind of regional protection available*): ARIPO (BW, GH,
GM, KE, LR, LS, MW, MZ, NA, RW, SD, SL, SZ, TZ,
UG, ZM, ZW), Eurasian (AM, AZ, BY, KG, KZ, RU, TJ,
TM), European (AL, AT, BE, BG, CH, CY, CZ, DE, DK,
EE, ES, FI, FR, GB, GR, HR, HU, IE, IS, IT, LT, LU, LV,
MC, MK, MT, NL, NO, PL, PT, RO, RS, SE, SI, SK, SM,
TR), OAPI (BF, BJ, CF, CG, CI, CM, GA, GN, GQ, GW,
ML, MR, NE, SN, TD, TG).

Published:

— with international search report (Art. 21(3))

(54) Title: METHOD FOR PRODUCING HIGH PURITY LIGNIN

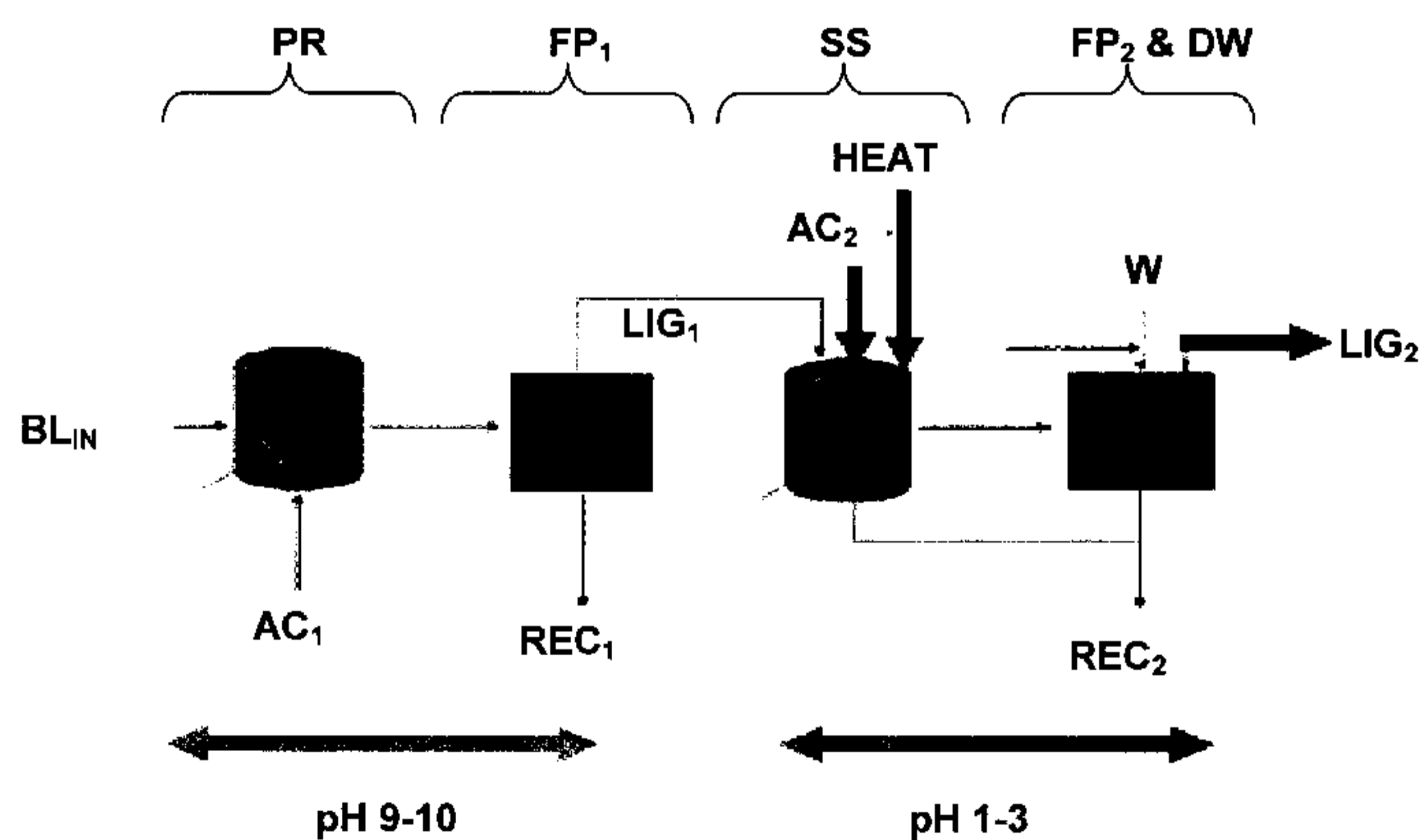

(57) Abstract: The present invention relates to a method for separation of lignin from original black liquor (BLIN) comprising a first precipitation stage (PR) for precipitation of lignin by a first acidification using acidifier AC, preferably using CO₂, at alkaline conditions, then separating a lignin cake with subsequent suspension of the lignin cake in a strong acid in order to leach our metals from the lignin followed by dewatering and obtaining a clean lignin product LP. According to the invention is the process further improved by intensified hydrolysis of lignin cake such that most of the carbohydrates are broken down to dissolvable monomers that could be separated from the lignin in the filtrate from a filtering stage subsequent to the hydrolysis. The improved hydrolysis could reduce as much as 90% of the carbohydrate content using a moderately increased temperature and increased charge of acidifier while avoiding any larger lignin yield losses.

Fig. 4

Method for producing high purity lignin

Technical Field

This invention relates to a method for producing high purity lignin, wherein lignin is separated from spent cooking liquor, called original black liquor, using a precipitation
5 process.

Background

The advantages with lignin separation from black liquor is already described in WO 2006/031175 and WO2006/038863. These patents disclose the novel process
10 **LignoBoost**TM that is now sold by Metso, and wherein WO 2006/031175 disclose the basic two stage acidic wash process and WO2006/038863 disclose an improvement of the process where sulphate or sulphate ions are added to the process.

The **LignoBoost**TM process was originally developed for production of an alternative
15 bio-fuel, where main focus was at reduction of residual metal content, especially sodium, as the residual metal content may corrode boiler or burners using the lignin fuel. In this objective to reduce residual metal content it was shown that it was very important to maintain the process at the acidic side, and leaching and washing of lignin was kept at pH between 2-3 avoiding redeposition of metals, especially
20 sodium, on the lignin.

An important aspect of the process is that the required charge of chemicals/acidifiers for the acidification and leaching of metals and subsequent washing may be high. If this is the case the cost of fresh chemicals is a large part of the operational cost and the commercial viability of the process is lower.

25 These problems could be reduced, if the process is optimized for minimum requirement for charges of fresh chemicals or acidifiers, keeping operational costs down and thus making the lignin product commercially sound.

Another consideration is to minimize the acidic waste flows from the process as conventional recovery of spent chemicals may be impeded if volumes of acidic waste
30 flows increase in relation to the alkaline bulk volume of black liquor being recovered. Most often must acidic waste flows be handled separately if volumes are excessive which increase investments costs in recovery systems as well as operational costs of the mill.

Acidifiers in form of mill generated waste flows is thus preferable as it may both solve a waste disposal problem and lessen environmental impact as well as such usage would decrease costs for new chemicals. As the precipitation of lignin requires acidification of alkaline black liquor flows, much of the total amount of acidifier is used to decrease the pH level down to the point of where lignin starts to precipitate. The first stage reaching this pH level typically reduce the pH level from about pH 13 in the original black liquor down to a pH level about 9,5-11,5.

The **LignoBoost**TM process produce a lignin product which if used as fuel is classified as a "green" fuel as being based upon recovered fuel. The idea with classification of "green" fuels is based upon the concept not to increase the carbon dioxide footprint, i.e. the emissions, by burning fossil fuels. The most promising acids for this process is carbon dioxide for at least initial precipitation of the lignin, and then using sulfuric acid (H₂SO₄) for washing and leaching out metals from the lignin. The sulfuric acid could be added as a fresh sulfuric acid from a chemical supplier, or as preferred using so called "spent acid" from a chlorine dioxide generator often used at a pulp mill. The latter usage of this spent acid already at hand in most mill sites further emphasize that the lignin product is considered as a "green" fuel.

However, interest in lignin as a base product for further usage has caught interest and in some applications further requirements on the lignin product is emphasized.

In US4.891.070 is disclosed a method for producing an improved aqueous printable ink composition from lignin. In this process extracting the lignin from the black liquor it is essential that the pH is not allowed to drop below pH 5 and adding an organic amine forming a lignin amine salt solution. In US4.891.070 is also disclosed other various methods of recovery, purification, and modification of lignin by-products as disclosed in US patents No: 2,525,433; 2,680,113; 2,690,973; 3,094,515; 3,158,520; 3,503,762; 3,726,850; 3,769,272; 3,841,887; 4,001,202; 4,131,564; 4,184,845; 4,308,203; and 4,355,996 and concludes that generally the processes for obtaining purified lignin, includes pH decrease of black liquor to about 9,5 with subsequent acidification of the precipitate to a pH of about 1,5 to 4, followed by water washing to displace inorganic salts and impurities therein. However, no indication of hydrolysis of carbohydrates is shown. Thus, it could be concluded that extensive research work

has been invested over several decades in finding the best process for obtaining a purified lignin product.

The original **LignoBoost**TM bio-fuel product produced a fuel with low residual levels of sodium and as it was used as a fuel no attention was drawn to the fact that the lignin fuel often had high levels of hemicelluloses, i.e. carbohydrates, as also hemicelluloses contributed to heat value of the fuel, even if the specific heat value of hemicelluloses is lower than pure lignin.

As the **LignoBoost**TM use black liquor from kraft pulping processes the hemicellulose content may vary considerably, and from worse case scenarios using cooking techniques like Lo-Solids Cooking could as much as 8-10% of the final lignin product correspond to hemicellulose/carbohydrate content.

Now is lignin considered also for usage in production of spun fibers, used when producing light weight construction details in automobiles and airplanes. But in this process the lignin purity must be higher and residual levels of hemicelluloses must be very low, well below 1 wt-%. In other applications are lignin also considered for production of chemicals and in these processes is higher lignin purity also a requirement.

It is known from handbooks in pulping processes that hemicelluloses could be removed from biomass in acidic prehydrolysis, which often was conducted at rather high temperatures. Prehydrolyse stages in pulping are typically conducted on the wood material at rather high temperatures, i.e. at about 170°C in auto- or water hydrolysis and some 120-140°C when wood material is slurried in dilute acid, all depending upon the established pH level (higher pH required higher temperature). In some applications have also prehydrolysis of wood chips been performed in strong acidic solutions (20-30% HCL at 40°C), but this process led to extensive lignin destruction as well as alpha cellulose losses. Thus, if hemicellulose is to be removed selectively has always diluted acids been used. The dissolved hemicelluloses may also be further degraded at acidic conditions.

However, lignin is also known to decompose to solvable lignin if subjected to heat treatment at about 190°C or higher, so the problem to reduce hemicelluloses content

in a lignin product is not that obvious while maintaining the lignin yield high as well as reducing consumption of acidifiers and keeping acidic waste flows low. A major concern when using the *LignoBoost*TM process has been the filterability of the lignin throughout the process, and heating of lignin is well known to cause softening of the lignin and that negatively affects filterability. So, solving the problem with carbohydrates in lignin is not that obvious as lignin yield should be kept high while carbohydrate content should be kept low.

Summary of the invention

10 The invention is based upon the surprising finding that an extensive hydrolysis of the lignin cake in the *LignoBoost*TM process could reduce the carbohydrate content in the lignin product considerably without any major losses in lignin produced. The major part of the non soluble carbohydrate oligomeres are broken down to dissolvable monomers that easily could be separated from the lignin in the filtrate
15 from a filtering stage subsequent to the hydrolysis.

Further, by implementing the hydrolysis in the reslurrying of the lignin cake filtered from the original black liquor flow could the liquid volumes needing heating be reduced considerably compared to implementing a hydrolysis of the original black
20 liquor flow.

Thus, the invention is related to a method for separation of lignin from original black liquor (BL_{IN}) having a first alkaline pH value, comprising the following stages in sequence:

25 a first precipitation stage (PR) wherein an acidifier charge is added to the original black liquor in order to decrease the pH value of the original black liquor to a second pH level initiating precipitation of lignin whereby said second pH level is above pH 7 and below 11.5,

30 followed by a first separation stage (FP₁) wherein the precipitated lignin is separated as a lignin cake (LIG₁) with a content of carbohydrates from the remaining liquid phase of the acidified original black liquor still kept in the pH range from neutral to alkaline,

characterized in that

lignin from the lignin cake with a content of carbohydrates is mixed in a

subsequent stage with a second acidifier added to the lignin cake forming an acidic slurry establishing a pH value in the range 1-3,

establishing a reaction temperature in the range 100-140°C in the acidic slurry,

5 maintaining the acidic slurry at the reaction temperature for a reaction time period during which at least 60% of the carbohydrates content is hydrolysed, said reaction time period resulting in a P-factor less than 20,

10 followed by a second separation stage in which the treated lignin content is separated from the acidic slurry and the carbohydrates dissolved in the acidic slurry forming a low carbohydrate lignin cake.

By this establishment of this low pH level in the re-slurried lignin cake as well as establishment of a rather modest temperature in this range for a period of time such that 60% of the carbohydrates content is hydrolysed, i.e. the non soluble oligomeres
15 broken down to soluble monomers, could the lignin product reduce carbohydrate content with low loss of lignin and at less heating requirements.

According to a preferred embodiment of the inventive method is the reaction temperature in the in the acidic slurry in the range of 100-120 °C and that the reaction
20 time period during which at least 60% of the carbohydrates content is hydrolyzed is in the range 10-60 minutes in inverse proportion to temperature, keeping the amount of lignin dissolved from the lignin cake below 15%.

By these method steps could the yield losses of lignin be reduced, and as shown in laboratory tests be kept at about 8%.

25 According to another embodiment of the invention is also a cooling effect introduced such that after the acidic slurry has been kept at the reaction temperature for a reaction time period during which at least 60% of the carbohydrates content is hydrolyzed, said acid slurry is subjected to cooling before subsequent separation of
30 the treated lignin content. By this cooling effect directly after the hydrolysis could further lignin degradation be reduced, keeping the lignin yield high.

Further according to a preferred embodiment, if the cooling effect is implemented such that the acidic slurry is cooled in an indirect heat exchanger against an acidifier to be used as the second acidifier, thereby reducing the temperature of the acidic

slurry by at least 40 °C. The heat economy of the process will this be improved as the heat value from the hydrolysis liquid is transferred to the acidifier used for hydrolysis.

According to an alternative or complementary embodiment of the invention are
5 reaction conditions established such that the acidic slurry has been kept at the reaction temperature for a reaction time period during which at least 60% of the carbohydrates content is hydrolyzed, said reaction temperature and time period corresponding to a P-factor not exceeding the P-factor established at a reaction temperature of 120 °C and a time period of 60 minutes, i.e. a P-factor below 8.

10

Further in yet better mode in reaction conditions established such that the acidic slurry has been kept at the reaction temperature for a reaction time period during which at least 90% of the carbohydrates content is hydrolyzed, said reaction temperature and time period corresponding to a P-factor equivalent to or exceeding
15 the P-factor established at a reaction temperature of 100 °C and a time period of 60 minutes, i.e. a P-factor above 1.

According to yet another embodiment of the invention is the lignin cake subjected to an additional acidification to a pH of at least 2-4 or lower followed by a third
20 separation of a third lignin cake as an additional treatment stage for leaching metals from said lignin cake, said additional treatment made either before or after obtaining the low carbohydrate lignin cake. By this embodiment could residual monosaccharide's be leached out from the lignin cake as well as residual metal content, as the acidic conditions in the leaching water is maintained avoiding
25 redeposition of metals and/or monomers. Preferably is also the lignin cake washed with washing water at a pH of at least 2-4 or lower after at least one of the separation stages.

It is intended throughout the present description that the expression "separation
30 stage" embraces any means of separation. Preferably the separation is performed by using centrifugation, a filter press apparatus, a band filter, a rotary filter, such as a drum filter, or a sedimentation tank, or similar equipment, most preferred a filter press apparatus is used.

It is intended throughout the present description that the expression "original black liquor" embraces spent cooking liquor from a digester, having most of the lignin from the original cellulose material dissolved in the "original black liquor". The "original black liquor" may also have a large content of organic and inorganic material, but
 5 may also have passed through separation processes for extracting turpentine or other specific constituents, while keeping the bulk volume of dissolved lignin unaltered.

In following description is the P-factor used, and corresponds to the recorded
 10 temperature/time data using an activation energy of 125.6 kJ/mol for the xylan removal (see Sixta, H. "Multistage kraft pulping" 2006, Handbook of Pulp, Wiley-VCH, Weinheim, pp. 325-365) during auto hydrolysis. The actual P-factor for different temperatures and retention time could be seen in below table.

P- Factor

$$\text{P-factor} = (e^{(40.48-15106/(273.15+\text{temp}))} \cdot \text{time}) / 60$$

Acc to Herbert Sixta Handbook of pulp, page 344

Time Min	Temperature °C						
	80	100	120	140	150	160	170
30	0	0	4	25	60	136	299
45	0	1	6	38	89	204	448
60	0	1	8	50	119	272	597
75	0	1	10	63	149	340	746
90	0	1	12	75	179	408	896
105	0	2	14	88	209	476	1045
120	0	2	16	100	238	544	1194
135	0	2	18	113	268	612	1344
150	0	2	20	126	298	680	1493
165	0	3	22	138	328	748	1642
180	0	3	23	151	358	816	1792
195	0	3	25	163	388	884	1941
210	0	3	27	176	417	951	2090
225	0	4	29	188	447	1019	2239
240	0	4	31	201	477	1087	2389
255	0	4	33	214	507	1155	2538
270	0	4	35	226	537	1223	2687
285	0	5	37	239	566	1291	2837
300	1	5	39	251	596	1359	2986

According to the invention it has been surprisingly found that a successful removal of carbohydrates at low lignin yield losses has been obtained by implementing a hydrolysis at moderate conditions, corresponding to a P-factor well below 20, and preferably in the P-factor range 1-10.

5

Short description of the figures

Fig. 1 shows the basic steps in prior art lignin separation process according to WO 2006/031175;

10 Fig.2 shows the liquid balance established in last two stages when using a process shown in Fig.1;

Fig. 3 shows content of the separated lignin using a process shown in Fig.1;

Fig. 4 shows a principle modification of the process shown in Fig. 1 establishing a first alternative for the inventive method;

15 Fig. 5 shows the liquid balance established in last two stages when using a process as shown in Fig.4;

Fig. 6 shows a principle modification of the process shown in Fig. 1 establishing a second alternative for the inventive method;.

Fig. 7 shows the liquid balance established in last two stages when using a process as shown in Fig.6;

20 Fig. 8 shows the the content of the lignin material before and after using the inventive method at different hydrolysis conditions;

Fig. 9 shows the residual carbohydrate content as a function of time and temperature;

25 Fig. 10 shows how the hydrolysis results in purified lignin fraction and another fraction dissolved in the hydrolysis liquid.

Detailed description of the invention

As a starting point for the invention was the **LignoBoost**TM process used, which is shown in principle in figures 1 and 2.

30 In figure 1 is the process according to WO 2006/031175 shown. The separation of lignin from original black liquor BL_{IN} comprising the following stages in sequence:

Precipitation of lignin by a first acidification stage PR of the original black

liquor BL_{IN} by adding a first acid or mixture of acids AC_1 , in any suitable precipitation reactor, followed by

dewatering while forming a first filter cake LIG_1 with high content of lignin, said dewatering made in any suitable filter press FP_1 , which may drain a first
5 filtrate REC_1 from the lignin suspension. In order to reduce the amount of liquid in the filter cake LIG_1 gas may be blown through the lignin cake in order to displace any residual black liquor (not shown), and subsequently

suspending the first lignin filter cake LIG_1 in a second acidification stage
SS using a second acid or mixture of acids AC_2 , said suspension made in any
10 suitable suspension tank. In this tank a second lignin suspension is obtained.

The second lignin suspension is thereafter sent to a dewatering and washing stage FP_2 & DW forming a second filter-/lignin cake LIG_2 with high content of lignin. Said dewatering made in any suitable filter press FP_2 , which may drain a second filtrate REC_2 from the lignin suspension, and at least a portion of this second
15 filtrate REC_2 may be re-circulated back to the suspension stage. Washing of the second filter cake is made in any suitable wash apparatus DW, adding a wash liquid W to this washing stage.

In view of the objective to obtain a purified lignin product having low residual levels of metal, especially sodium, while consuming less acidifiers and hence produce less
20 volume of acidic waste flow volumes, and at low costs for acidifiers, some process conditions have been found best suitable. It has been found that carbon dioxide is the preferred first acidifier AC_1 as carbon dioxide may be found in waste gases in a pulp mill. Hence, using carbon dioxide in waste gases solves both a waste gas problem as well as decrease of external chemicals. The conditions in the first
25 precipitation stage is kept at a pH in the range 9-10, i.e. still alkaline, which results in that the bulk volume of black liquor BL_{IN} treated in the precipitation stage is kept in the filtrate REC_1 and may thus be reintroduced to the recovery operations without inflicting any dramatic pH changes in the recovery process. The relatively small volume share of the lignin cake LIG_1 is the only volume needing further acidification
30 for leaching of metals from the lignin, which means that the volumes of the second acidifier AC_2 is low in relation to original black liquor volumes. In order to obtain sufficient leaching of metals the leaching process has been kept at operating conditions at pH 2-4 at 50-60 °C. A lignin product could be produced at these

conditions with very low residual content of sodium, thus suitable as a fuel in combustion plants.

Fig.2 shows the liquid balance established in last two stages when using a process shown in Fig.1. Here is the FP₂ & DW stage shown as separated stages. The first
5 lignin filter cake LIG_1 is acidified using sulfuric acid, i.e. H_2SO_4 .

In Fig.3 is shown the organic composition of the lignin cake obtained by using a process according to Fig.2, when treating an original black liquor obtained from a Soda-AQ cooking process with so called Lo-Solids cooking circulations during the cook. Lo-Solids implies that black liquor is withdrawn in several positions during the
10 cook and replaced with cooking liquor with low content of Dissolved Organic Material, i.e. DOM. This result in that both lignin and carbohydrates, i.e. hemicelluloses, is withdrawn from cook and ends up in the black liquor. As shown in the 3 lignin samples BL3, BL3 and BL2 obtained is the carbohydrate content as high as between 10.1 to 11.2 %. The relative composition of carbohydrates is shown in lower part of
15 the table and as much as 85.5 to 86.5% of the carbohydrates consist of Xylose.

In figure 4 is shown a first preferred embodiment of the inventive method. The new method steps as compared with the previous process shown in figure 1 and 2 is the intensified acidification of the lignin cake LIG_1 and moderate heating of the acidified and reslurried lignin cake LIG_1 in the second acidification stage SS using a second
20 acid or mixture of acids AC_2 . The advantage with this embodiment is that no additional equipment is needed in comparison to the previous process as shown in figure 1, besides additional heating and addition of more acidifier. Fig.5 shows the liquid balance established in last two stages when using the first preferred embodiment of the inventive method shown in Fig.4. In comparison with the liquid
25 balance as disclosed in Fig.2, is the amount of added sulfuric acid increased from 200kg up to 390kg per ton of lignin produced, i.e. an increase of about 95%. The charge of fresh sulfuric acid is 310kg obtaining 0,8 t of lignin, which results in a relative charge of $310/0.8 = 387$ kg per ton of lignin produced. As a result of the moderately intensified conditions in the second acidification stage is almost all of the
30 carbohydrate content broken down to soluble monomers. As could be seen in this first preferred embodiment is the only additional equipment needed an heat

exchanger HE and a somewhat larger pressurized vessel for the re-suspending and hydrolysis stage, but at some larger charge of acidifiers.

In figure 6 is shown a second preferred embodiment of the inventive method. In contrast to the first embodiment shown in figure 4 is the carbohydrates removed in an additional purification stage added after the process as shown in figure 1 and 2. Fig.7 shows the liquid balance established when using as additional purification stage according to the second preferred embodiment of the inventive method shown in Fig.6. In comparison with the liquid balance as disclosed in Fig.2, is the amount of added sulfuric acid per ton of lignin precipitated increased from 200kg from figure 2 up to 250kg, i.e. a modest increase of about 25%. The charge of fresh sulfuric acid is made by adding only 20 kg to the resuspending stage while 180 kg fresh sulfuric acid is added to re-slurry stage (as about 20 kg is contained in Acid purge flow which results in same total charge of 200 kg in this position as in figure 2) obtaining 0,8 t of lignin, which results in a relative charge of $200/0.8 = 250\text{kg}$ per ton of lignin produced. The reasons for the modest increase of acidifier is that the intensified acidification to a pH of about 1,3 in last re-suspending and hydrolysis, compared to a pH of about 2-3 in preceding stages, is that a large part of the acidic filtrate is returned from a subsequent filtration stage, i.e. about 3,6 t liquor, while 0,78 t of the filtrate, i.e. more than 20% of the filtrate, from the filtration is purged from the stage and sent to first reslurry stage. Hence, the addition of fresh acidifier should replace the amount purged from the stage. A result of the moderately intensified conditions in the second acidification stage is that almost all of the carbohydrates are broken down to soluble monomers. As could be seen in this second preferred embodiment is the required additional charge of acidifiers reduced considerably but instead is additional equipment needed in form of additional pressurized vessel for the re-suspending and hydrolysis stage and following filtration and washing stages with associated piping.

The first preferred embodiment results in reduced investment costs, if this is the primary objective, and the second preferred embodiment results in reduced operating costs as the charge of acidifiers is reduced considerably, and the second preferred embodiment is justified if available space is at hand at the mill for the extra equipment and the pay-off time is acceptable (cost for chemicals VS investment costs).

CARBOHYDRATE REMOVAL EXPERIMENTS

Carbohydrate removal was tested in laboratory using a 0,5 liter mechanically stirred reactor using lignin obtained from black liquor. 10-15 g of oven dry lignin suspended in 200 ml liquid was used in each test. The conditions for the carbohydrate hydrolysis tested was in the temperature range 80-120°C, at reaction time 10-60 minutes and at an established acidity of 0,5-4% H₂SO₄.

After the hydrolysis was the solid product carbohydrate content analyzed using acid hydrolytic method (HPAEC+PAD detection of sugars). The dissolved lignin content in the filtrate was analyzed with UV analysis.

10 The constitution of the starting lignin material was as indicated in Fig.8. and several experiments were done, and results are plotted in Fig. 9. What could be seen here is that all tests done at a hydrolysis temperature of 120°C all achieved a residual level of carbohydrates under 1 wt-%.

One test done at 100°C and at retention time of 60 minutes achieved a residual level of carbohydrates under 1 wt-%. It is thus clear that the minimum P-factor for achieving a carbohydrate content below 1 wt-% corresponds to this test point. Using the P-factor as defined by H.Sixta this lower operating point corresponds to a P-factor of about 1. And the tests have done at 120°C indicate that there is not much to be gained by increasing the retention time more than 10 minutes at 120°C. Using the P-factor as defined by H.Sixta this upper operating point corresponds to a P-factor of about 8 if retention time is 60 minutes.

Thus it is clear that a reasonable upper limit of the P-factor corresponds to this point, as increase of retention time to 30 and 60 minutes would not decrease carbohydrate content in any major regard and further increase of P-factor would likely induce losses in lignin yield.

The final result of the carbohydrate removal is shown in principle in Fig.10. As shown in this figure is some 17-20 wt-% of the initial lignin lost as dissolved carbohydrates and dissolved lignin in roughly about 50/50 proportions. As about 8% of the lignin content is dissolved roughly 9-12% of the initial lignin content of carbohydrates is dissolved amounting to more than 90% of the total carbohydrate content. The purified

lignin after the hydrolysis is then sufficiently clean for other purposes where residual carbohydrate content must be below 1-wt%, and the lignin fraction of the initial lignin suffers a yield loss below 10%. The test examples was all conducted at a charge of H₂SO₄ of 1.0 wt-%, which was found to be sufficient in order to establish a pH level of about 1.3 in the hydrolysis stage.

POSSIBLE MODIFICATIONS

Other acidifiers than H₂SO₄ may be used, but sulfuric acid is preferred as sulfur is a common chemical component in black liquor in kraft pulping. However there may be a need for purging sulfur in order to keep the sodium/sulfur balance of the mill. Using HCl as an alternative acidifier is often not preferred as it will introduce chlorides into the chemical cycle of the mill.

PATENT CLAIMS

1. A method for separation of lignin from original black liquor (BL_{IN}) having a first alkaline pH value, comprising the following stages in sequence:

5 a first precipitation stage (PR) wherein an acidifier charge is added to the original black liquor in order to decrease the pH value of the original black liquor to a second pH level initiating precipitation of lignin whereby said second pH level is above pH 7 and below 11.5,

10 followed by a first separation stage (FP₁) wherein the precipitated lignin is separated as a lignin cake (LIG₁) with a content of carbohydrates from the remaining liquid phase of the acidified original black liquor still kept in the pH range from neutral to alkaline,

characterized in that

15 lignin from the lignin cake with a content of carbohydrates is mixed in a subsequent stage with a second acidifier added to the lignin cake forming an acidic slurry establishing a pH value in the range 1-3,

establishing a reaction temperature in the range 100-140°C in the acidic slurry,

20 maintaining the acidic slurry at the reaction temperature for a reaction time period during which at least 60% of the carbohydrates content is hydrolysed, said reaction time period resulting in a P-factor less than 20,

25 followed by a second separation stage in which the treated lignin content is separated from the acidic slurry and the carbohydrates dissolved in the acidic slurry forming a low carbohydrate lignin cake.

25

2. A method according to claim 1 **characterized in** that reaction temperature in the in the acidic slurry is in the range of 100-120 °C and that the reaction time period during which at least 60% of the carbohydrates content is hydrolyzed is in the range 10-60 minutes in inverse proportion to temperature, keeping the amount of
- 30 lignin dissolved from the lignin cake below 15%.

3. A method according to claim 1 **characterized in** that after the acidic slurry has been kept at the reaction temperature for a reaction time period during which at

least 60% of the carbohydrates content is hydrolyzed, said acid slurry is subjected to cooling before subsequent separation of the treated lignin content.

4. A method according to claim 2 **characterized in** that after the acidic slurry is cooled in an indirect heat exchanger (HE) against an acidifier to be used as the second acidifier, thereby reducing the temperature of the acidic slurry by at least 40 °C.
5. A method according to claim 3 **characterized in** that the acidic slurry has been kept at the reaction temperature for a reaction time period during which at least 60% of the carbohydrates content is hydrolyzed, said reaction temperature and time period corresponding to a P-factor not exceeding the P-factor established at a reaction temperature of 120 °C and a time period of 60 minutes, i.e. a P-factor below 8.
6. A method according to claim 5 **characterized in** that the acidic slurry has been kept at the reaction temperature for a reaction time period during which at least 90% of the carbohydrates content is hydrolyzed, said reaction temperature and time period corresponding to a P-factor equivalent to or exceeding the P-factor established at a reaction temperature of 100 °C and a time period of 60 minutes i.e. a P-factor above 1.
7. A method according to claim 1 **characterized in** that the lignin cake is subjected to an additional acidification to a pH of at least 2-4 or lower followed by a third separation of a third lignin cake as an additional treatment step for leaching and washing metals from said lignin cake, said additional treatment made either before or after obtaining the low carbohydrate lignin cake.
8. A method according to claim 1 or 7 **characterized in** that the lignin cake is washed with washing water at a pH of at least 2-4 or lower after at least one of the separation stages.

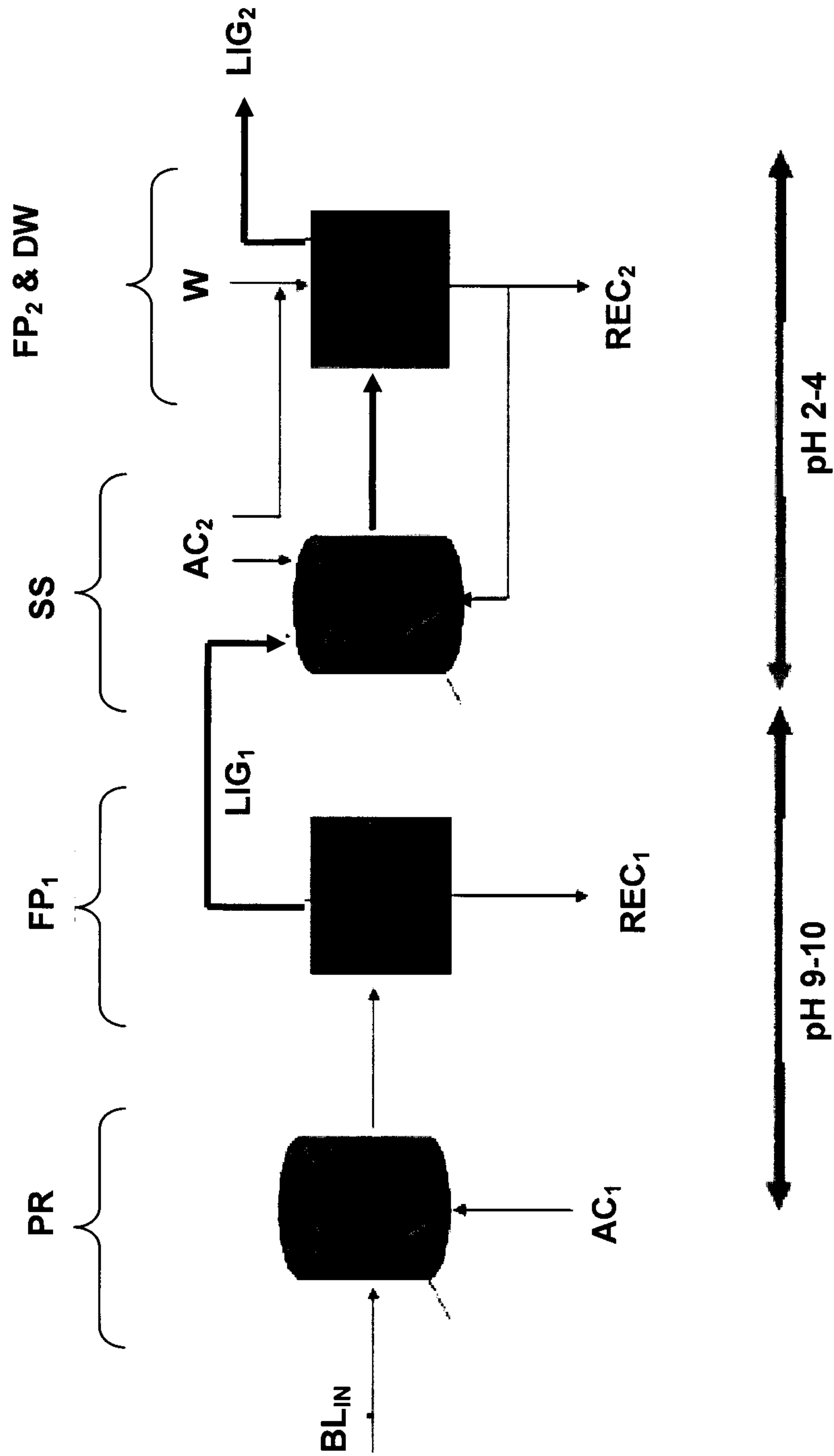

Fig. 1
Prior Art

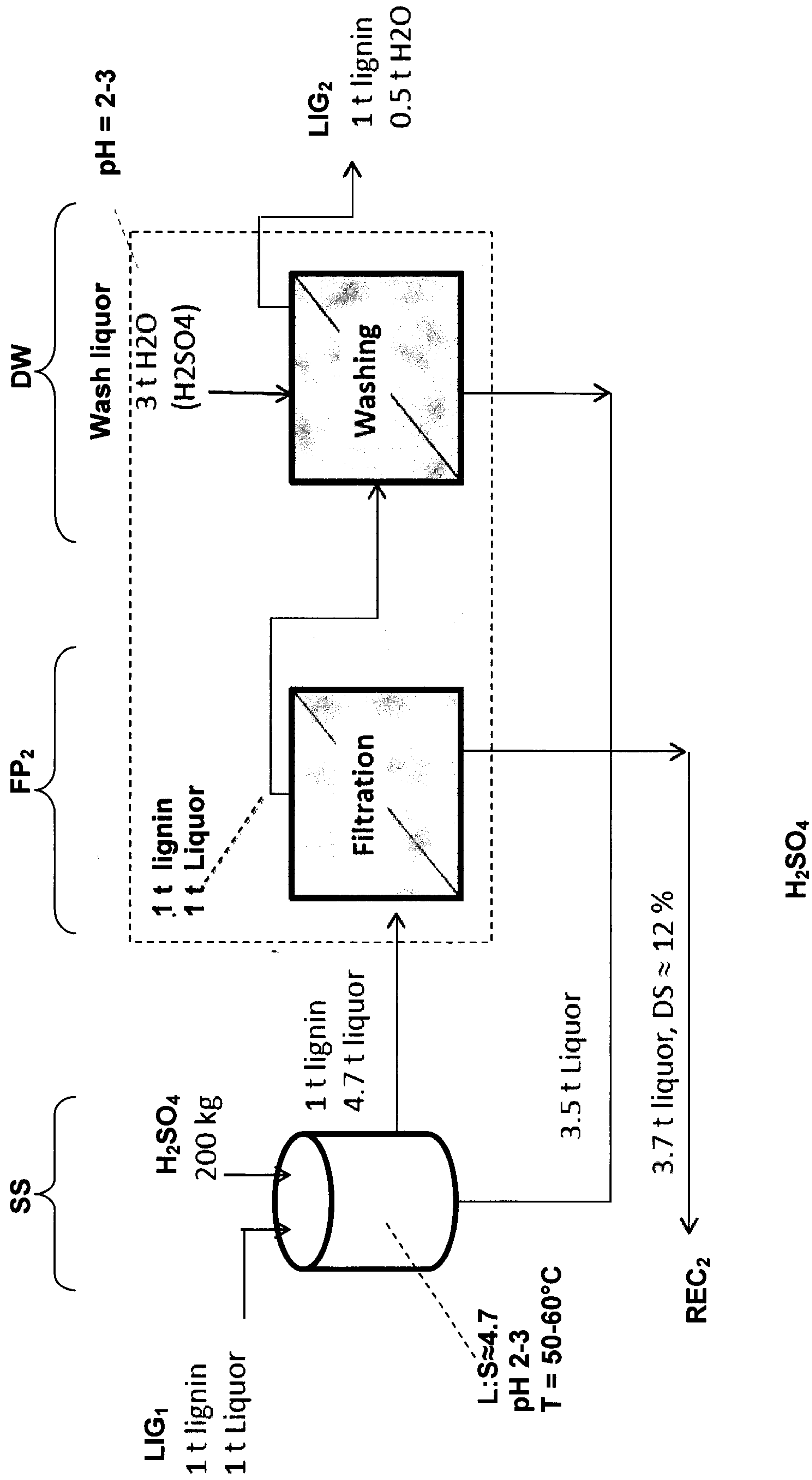

Fig. 2
Prior Art

Lignin from black liquor:		BL3	BL3	BL2
Klason lignin	%-W*	71.5	71.5	75.0
Acid soluble lignin	%-W*	13.5	16.4	14.4
Carbohydrates	%-W*	11.2	10.1	10.8
Extractives	%-W*	0.97		
Relative composition of carbohydrates:				
Arabinose	%**	2.4	3.4	3.0
Galactose	%**	2.8	3.1	2.9
Glucose	%**	9.2	6.9	7.8
Xylose	%**	85.5	86.5	86.1
Mannose	%**	0.1	0.1	0.1

* %-w of DS

** %-w of total carbohydrate content

Fig. 3
Prior Art

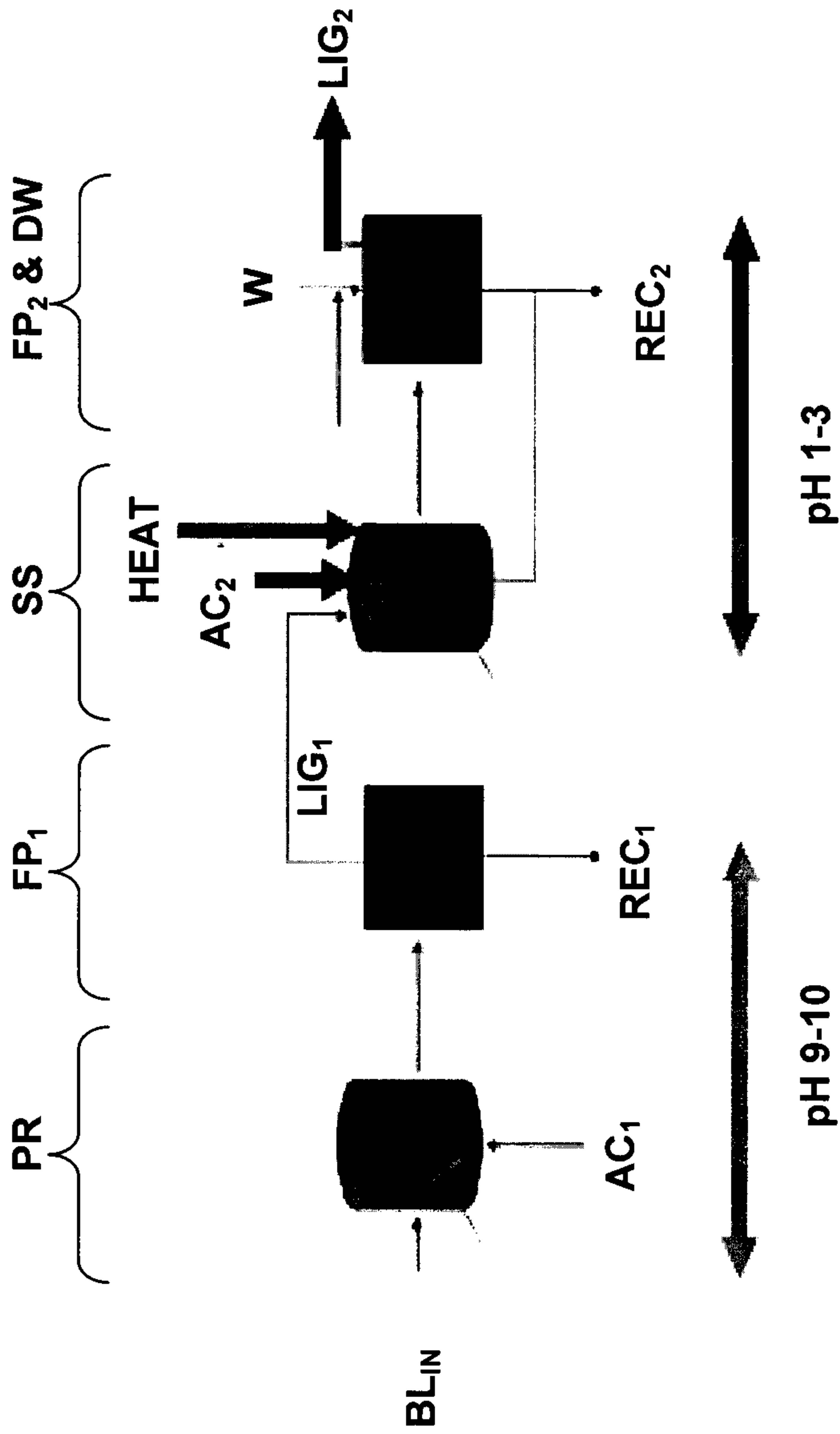

Fig. 4

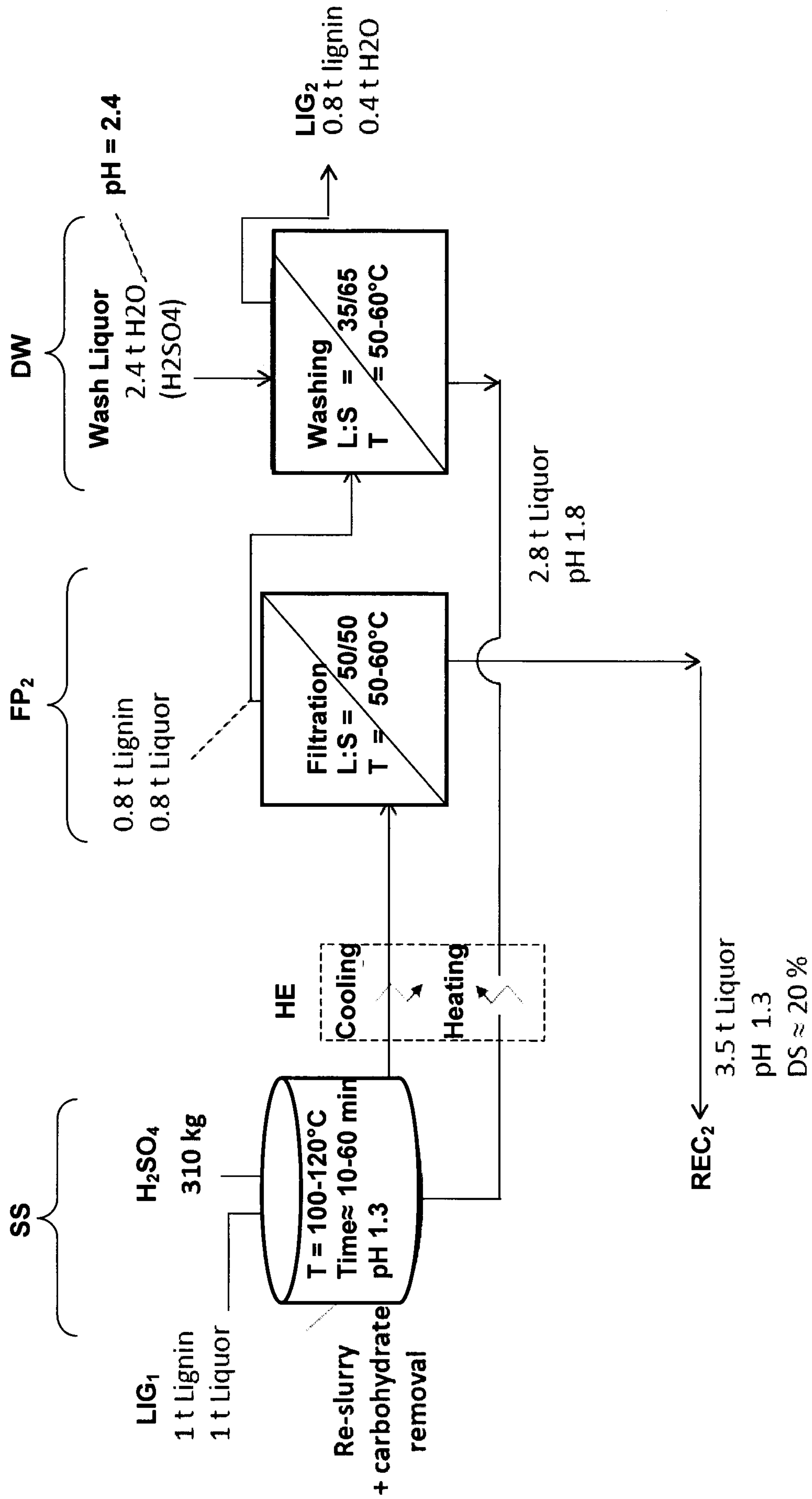

Fig. 5

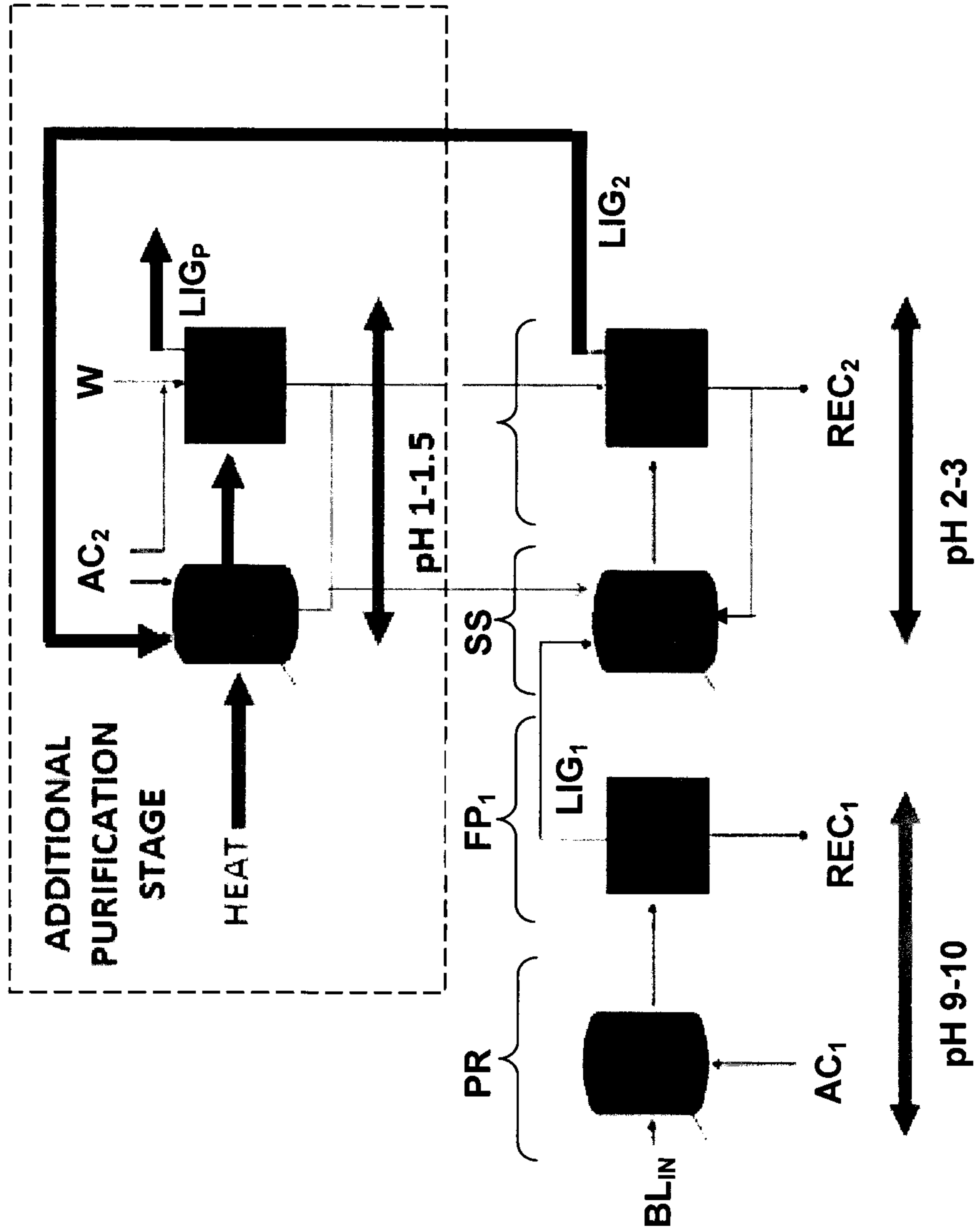

Fig. 6

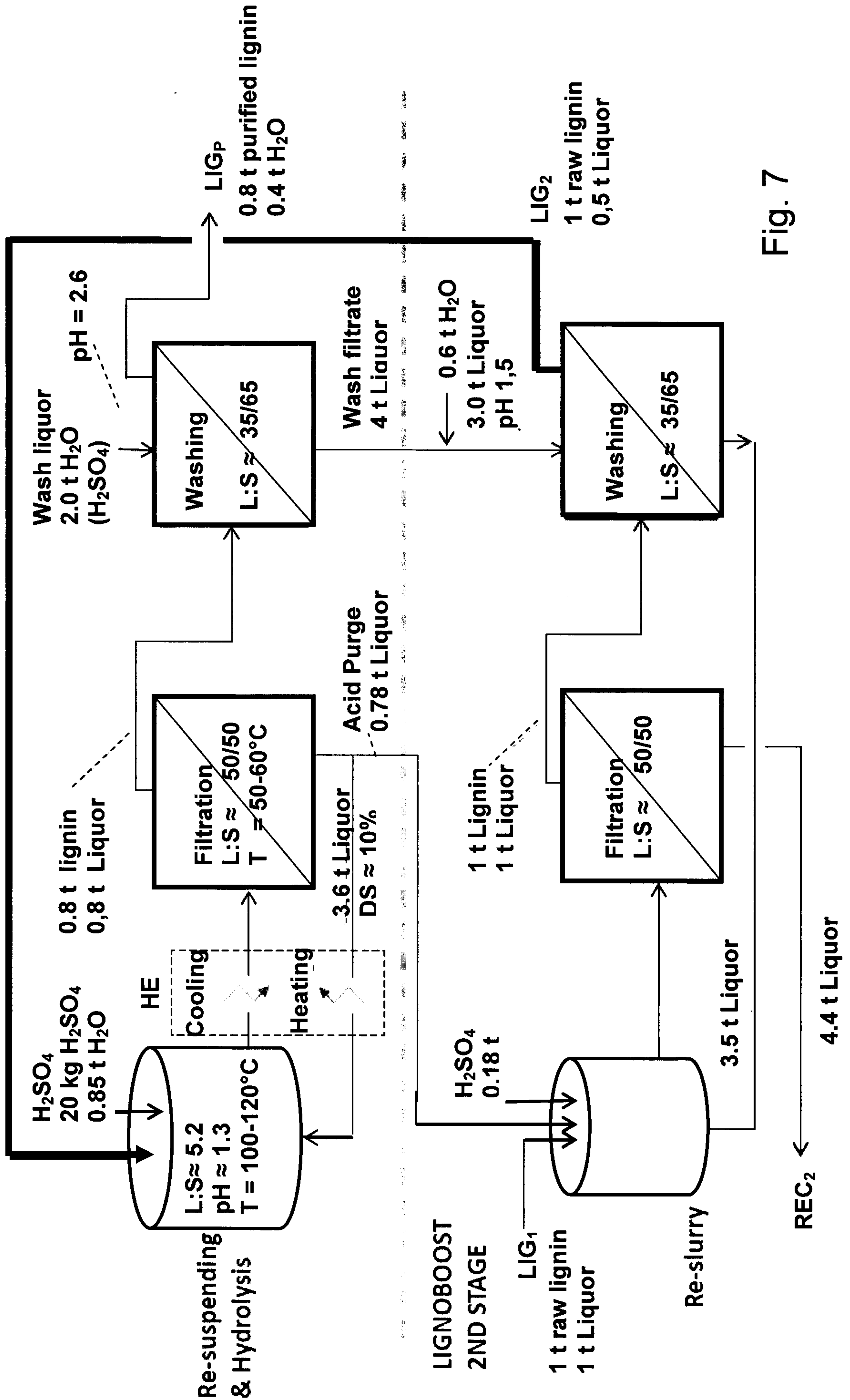

Fig. 7

Expt No.	Experimental conditions			Carboh. Analysis Results (Labtium)						
	H2SO4 %-w in solution	Time min	Temp °C	Ara g/100g	Gal g/100g	Glu g/100g	Xyl g/100g	Man g/100g	TOTAL SUGARS analyzed g/100g	TOTAL SUGARS anhydr.* g/100g
Starting material	-	-	-	0.2	0.4	0.8	7.5	0.1	9.0	7.9
2	1.0	60	120	<0.1	<0.1	0.5	0.2	<0.2	0.7	0.6
3	1.0	60	100	<0.1	<0.1	0.5	0.4	<0.2	0.9	0.7
4	1.0	60	80	0.1	0.2	0.2	5.8	<0.2	6.3	5.7
11	1.0	30	120	<0.1	<0.1	0.1	0.4	<0.2	0.5	0.5
12	1.0	10	120	<0.1	<0.1	0.1	0.3	<0.2	0.4	0.4
21	1.0	10	100	0.1	0.2	0.2	5.7	<0.2	6.3	5.6
22	1.0	10	80	0.2	0.3	0.5	7.4	<0.2	8.4	7.4
31	1.0	30	120	<0.1	<0.1	<0.1	0.2	<0.2	0.2	0.2
32	1.0	30	100	<0.1	0.1	0.2	2.7	<0.2	3.0	2.6
33	1.0	30	80	0.1	0.2	0.4	6.7	<0.2	7.4	6.6

* Conversion factors used: 0.90 for hexoses; 0.88 for pentoses

Fig. 8

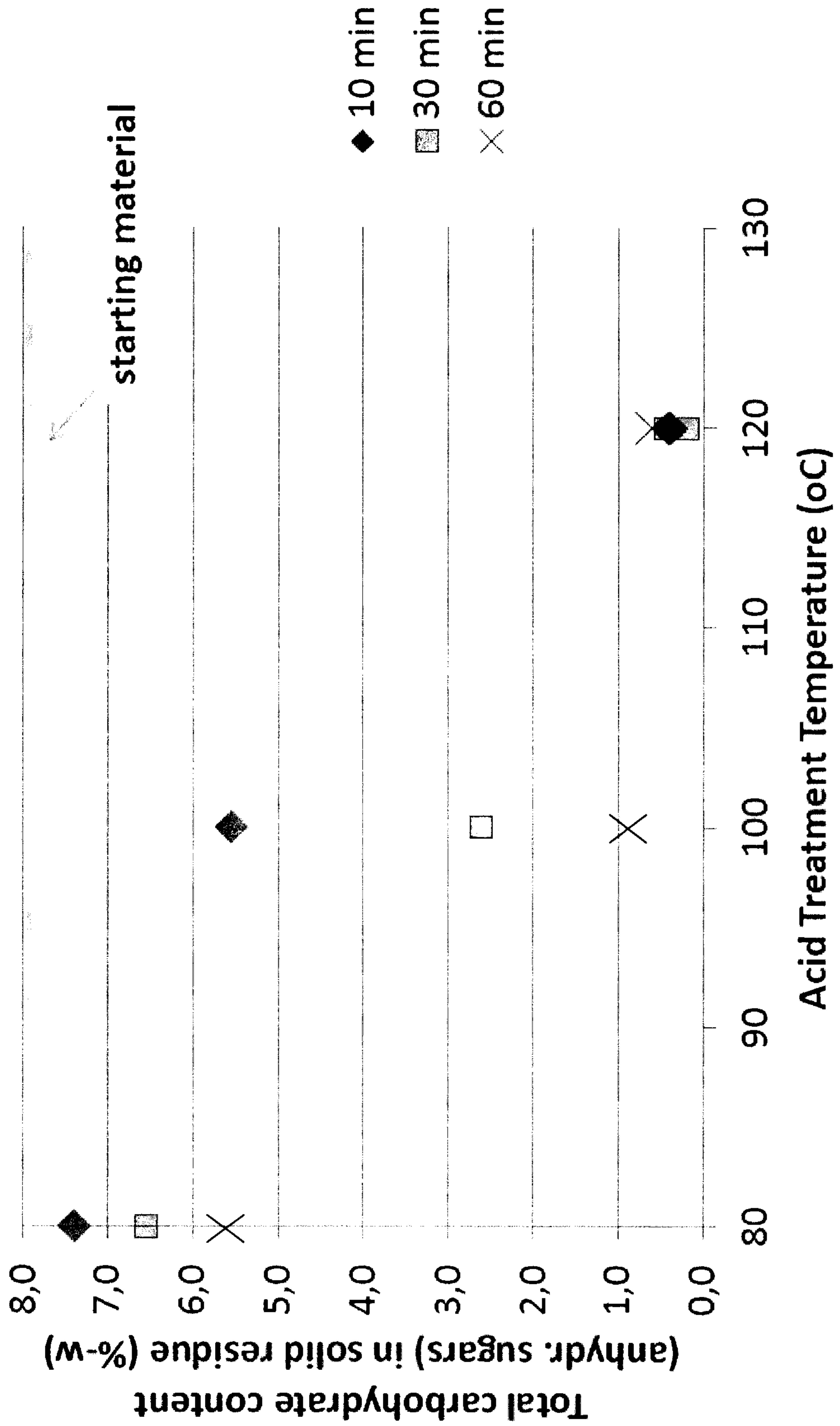

Fig. 9

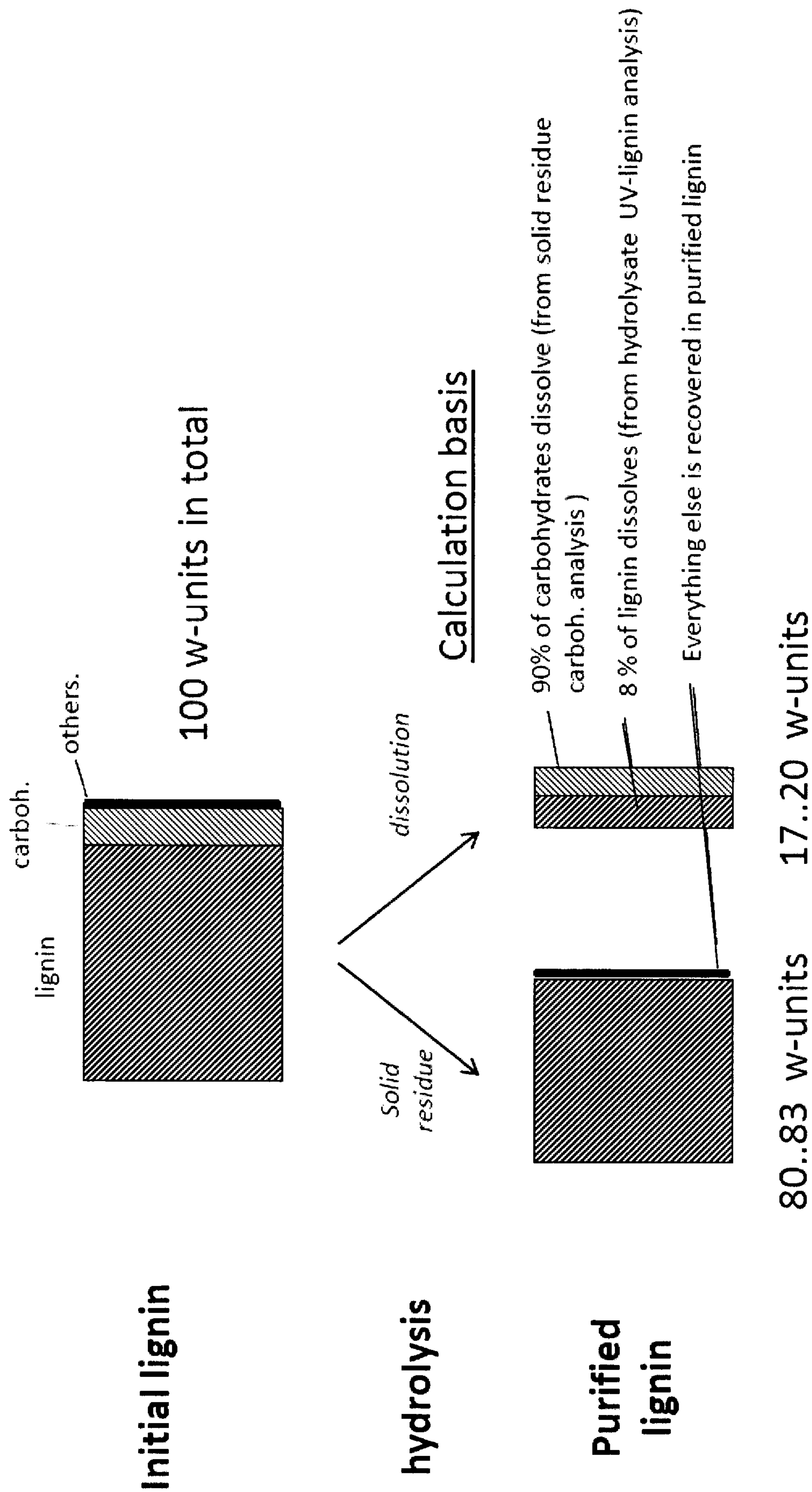

Fig. 10

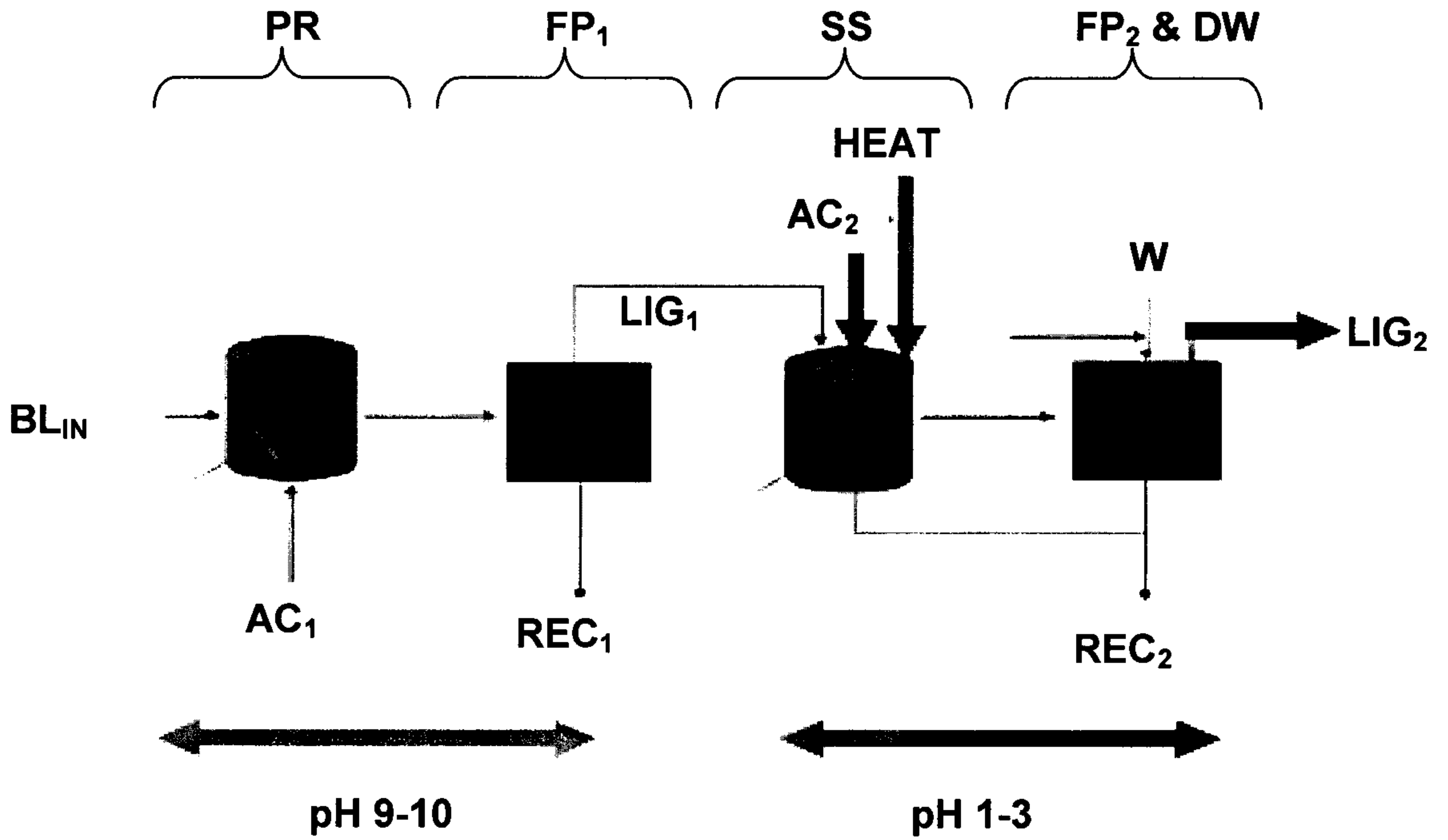

Fig. 4