

May 21, 1929.

C. E. JOHNSON

1,714,266

ADJUSTABLE CABINET DISH TRAY

Filed Sept. 15, 1927

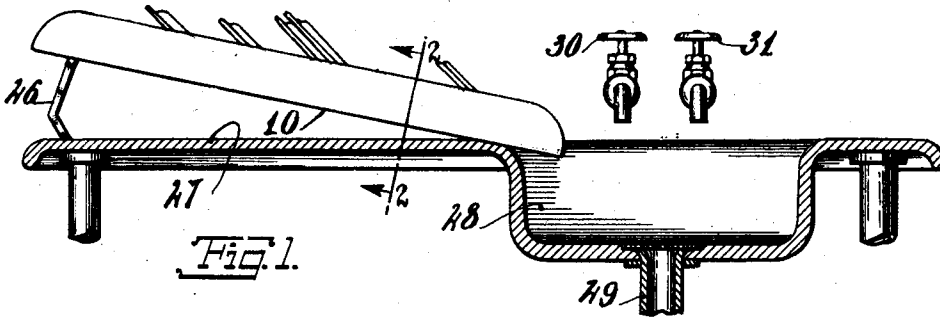

Fig. 1.

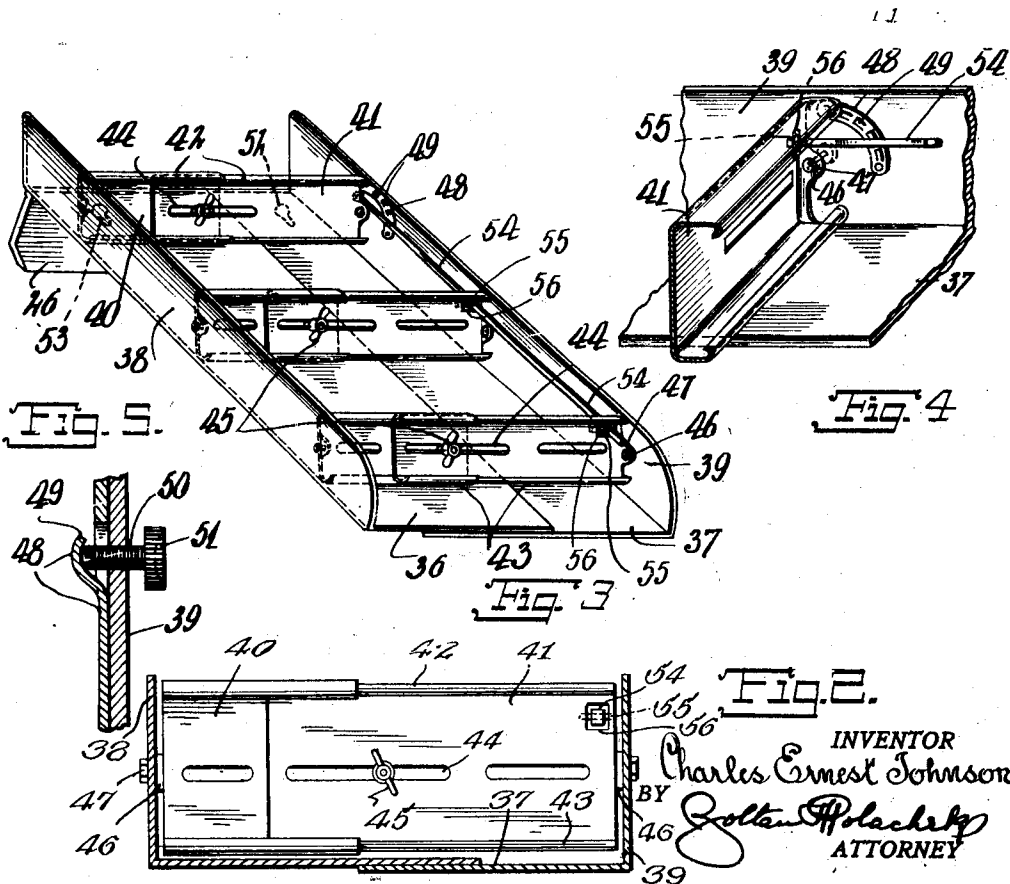

Fig. 5.

Fig. 4.

Fig. 3.

Fig. 2.

INVENTOR
Charles Ernest Johnson
BY
Gottlieb Polachek
ATTORNEY

UNITED STATES PATENT OFFICE.

CHARLES ERNEST JOHNSON, OF NEW YORK, N. Y.

ADJUSTABLE CABINET DISH TRAY.

Application filed September 15, 1927. Serial No. 219,601.

This invention relates to a new and useful device in the nature of a combination shelf and dish rack especially adapted for the purpose of providing suitable shelves for books, bric-a-brac, or the like, or to be used on a kitchen sink, or wash stand, for the purpose of drying dishes.

The object of the invention is to provide a combination shelf and dish rack of novel construction and arrangement of parts herein-after more fully described, claimed, and illustrated in the accompanying drawing.

Fig. 1 illustrates a side elevational view of my improved device as same would appear when in use for drying dishes applied to a kitchen sink shown in section.

Fig. 2 is an enlarged sectional view taken on the line 2—2 of Fig. 1.

Fig. 3 is a perspective view of the device.

Fig. 4 is an enlarged fragmentary view thereof.

Fig. 5 is a fragmentary sectional view of the adjustable engaging device as embodied therein.

As here embodied my improved device comprises a body member and shelves mounted therein, and an upright member 26 or support is secured to the body member 10 at or near one extremity thereof and is adapted to hold my improved device in an angularly inclined position when placed on the sink 27 as shown in Fig. 1.

In Fig. 1, I have shown the usual sink 27 such as is ordinarily used in kitchens provided with the basin 28 having the drain pipe 29 connected thereto and provided with the usual hot and cold water faucets 30 and 31, positioned above the basin 28. The above described elements are those of ordinary construction and here illustrated merely to more clearly show the use of my improved device as adapted for drying dishes.

I have shown my improved device consisting of a body member two separate sections 36 and 37 having their outer edges 38 and 39 formed or bent upwardly therefrom to form flanges. The shelves are constructed in two separate pieces 40 and 41 having their front and rear edges formed or bent as at 42 and 43 therefrom to form flanges and somewhat curved. The shelves 40 are of suitable size to slidably engage inside the shelves 41. The shelves 41 have formed therein elongated longitudinal openings 44 adapted to receive the thumb screws 45 secured to the shelves

40 as a means of holding the shelves 40 and 41 in an extended position as may be desired.

The shelves 40 and 41 are provided with end elements 46, or lugs, at the center of the ends thereof, formed or bent therefrom, and each having formed therein an aperture adapted to receive the pin 47, bolt, screw, or the like, as a means of pivotally securing the shelves 40 and 41 to the sides of the body members 36 and 37.

An engaging member 48 of arc shaped construction preferably of spring steel is secured to the inner portion of the side flange 39 in proximity to the upper one of the said shelves 41 and has formed or bent outwardly therefrom prong elements 49 adapted to engage the adjacent edge of the said upper shelf so as to hold the said shelf in any desired relatively angular position. The threaded member 50 is threadedly mounted in the side 39 of the above mentioned body member 37 and is provided with an enlarged head 51. The above described construction is such as will permit one of the prongs 49 to be held in a fixed extended position as a means of rigidly holding the upper shelf in a horizontal position so as to permit books, bric-a-brac, or the like to be retained on the said upper shelf when my improved device is suspended or hung on the wall. The prongs 49 must be manually forced into retracted positions out of the path of the shelf 41 when the latter is swung to desired angular positions. Openings 52 and 53 are formed in the upper portions of the body members 36 and 37 adapted to receive hooks, or the like, not shown in the accompanying drawing, as a means of hanging my improved device on the wall of a room when used as a shelf.

The said shelves 41 are interconnected by means of a rod 54 freely mounted on the pins 55 secured to the said shelves 41 and extending through openings 56 in the shelves 41. The latter described construction is such as will permit the shelves 40 and 41 to be held in any desired angular position simultaneously.

It should be understood that the said shelves 40 and 41 when held in angular positions, as above set forth, will permit dishes of various sizes or diameters to be held at the same angular position; it being further understood that dishes of the same relative size are dried at the same time.

Having thus described my invention what

I claim as new and desire to protect by Letters Patent of the United States is as follows:

1. In a device of the class described, a body formed of relatively movable members having side flanges, shelves pivotally mounted between said side flanges, an arc shaped member attached to the body member and having means for holding one of the said shelves in various inclined positions, and rods connected with all the shelves and arranged for simultaneously angularly positioning the shelves as directed by the said one shelf.

2. In a device of the class described, a body formed of relatively movable members having side flanges, shelves pivotally mounted between said side flanges, an arc shaped member with outwardly projecting prong elements, attached to the body member for holding one of the said shelves in various inclined positions, and rods connected with all

the shelves and arranged for simultaneously angularly positioning the shelves as directed by the said one shelf.

3. In a device of the class described, a body formed of relatively movable members having side flanges, shelves telescopically arranged and pivotally mounted in the said side flanges, a means of holding the said shelves in an extended position, an engaging member secured to the said body member, said engaging member provided with prong elements adapted to engage one of the said shelves as a means of holding the said shelves in an angularly inclined position, said shelves being inter-connected by rods pivotally secured thereto.

In testimony whereof I have affixed my signature.

CHARLES ERNEST JOHNSON.