

[19]	INTELLECTUAL PROPERTY PHILIPPINES		
[12]	INVENTION PUBLICATION		
[11]	Publication Number:	12016500857	Document Code: B1
[22]	Publication Date:	27/6/2016	
[21]	Application Number:	12016500857	Document Code: A
[22]	Date Filed:	10/5/2016	
[54]	Title:	APPARATUS, METHOD AND ARTICLE FOR PROVIDING VEHICLE EVENT DATA	
[71]	Applicant(s):	GOGORO INC	
[72]	Inventor(s):	TAYLOR MATTHEW WHITING LUKE HOK-SUM HORACE	
[30]	Priority Data:	8/11/2013 US201361901660P	
[51]	International Class 8:	B60R 16/02 20060101AFI20180820BHPH;	
[57]	Abstract:	<p>Detected events such as impacts, accidents, breakdowns, and types of driving behaviors based on feedback from tilt, gravity, accelerometers and/or shock sensors within a portable electrical power storage device such as a battery and/or within a vehicle (e.g., an electric scooter) are communicated to the user's mobile device, dashboard display and/or backend systems over wired and/or wireless communication channels. The communication of the events and types of events are logged and automatically aggregated from multiple vehicles for further analysis to determine various potential system-wide safety issues and to track event history on an individual per-user or individual per-scooter basis or individual per-battery basis. Such event data may also be transferred accordingly via the battery exchange process at the online exchange machine through a memory device attached to the battery that stores the event data.</p>	

"comprises" and "comprising" are to be construed in an open, inclusive sense that is as "including, but not limited to."

5 Reference throughout this specification to "one embodiment" or "an embodiment" means that a particular feature, structure or characteristic described in connection with the embodiment is included in at least one embodiment. Thus, the appearances of the phrases "in one embodiment" or "in an embodiment" in various places throughout this specification are not necessarily all referring to the same embodiment.

10

The use of ordinals such as first, second and third does not necessarily imply a ranked sense of order, but rather may only distinguish between multiple instances of an act or structure.

15

Reference to portable electrical power storage device means any device capable of storing electrical power and releasing stored electrical power including but not limited to batteries, supercapacitors or ultracapacitors. Reference to batteries means chemical storage cell or cells, for instance rechargeable or secondary battery cells including but not limited to gel lead-acid, absorbed glass mat lead acid, nickel cadmium alloy, nickel-zinc, nickel metal hydride or lithium ion battery cells.

20

The headings and Abstract of the Disclosure provided herein are for convenience only and do not interpret the scope or meaning of the embodiments.

25

Figure 1 shows an environment 100 including a collection, charging and distribution machine 102, according to one illustrated embodiment.

30

The collection, charging and distribution machine 102 may take the form of a vending machine or kiosk. The collection, charging and distribution machine 102 has a plurality of receivers, compartments or receptacles 104a, 104b-104n (only three called out in Figure 1, collectively 104) to removably receive portable electrical energy storage devices (e.g., batteries, supercapacitors or

ultracapacitors) 106a-106n (collectively 106) for collection, charging and distribution. As illustrated in Figure 1, some of the receivers 104 are empty, while other receivers 104 hold portable electrical energy storage devices 106. While Figure 1 shows a single portable electrical energy storage device 106 per receiver 104, in some embodiments each receiver 104 may hold two or even more portable electrical energy storage devices 106. For example, each of the receivers 104 may be sufficiently deep to receive three portable electrical energy storage devices 106. Thus, for example, the collection, charging and distribution machine 102 illustrated in Figure 1 may have a capacity capable of simultaneously holding 40, 80 or 120 portable electrical energy storage devices 106.

The portable electrical energy storage devices 106 may take a variety of forms, for example batteries (e.g., array of battery cells), supercapacitors or ultracapacitors (e.g., array of ultracapacitor cells). For example, the portable electrical energy storage devices 106z may take the form of rechargeable batteries (i.e., secondary cells or batteries). The portable electrical energy storage devices 106z may, for instance, be sized to physically fit, and electrically power, personal transportation vehicles, such as all-electric scooters or motorbikes 108. As previously noted, combustion engine scooters and motorbikes are common in many large cities, for example in Asia, Europe and the Middle East. The ability to conveniently access charged batteries throughout a city or region may allow the use of all-electric scooters and motorbikes 108 in place of combustion engine scooters and motorbikes, thereby alleviating air pollution, as well as reducing noise.

The portable electrical energy storage devices 106 (only visible for portable electrical energy storage device 106z) may include a number of electrical terminals 110a, 110b (two illustrated, collectively 110), accessible from an exterior of the portable electrical energy storage device 106z. The electrical terminals 110 allow charge to be delivered from the portable electrical energy storage device 106z, as well as allow charge to be delivered to the portable electrical energy storage device 106z for charging or recharging the same. While illustrated in Figure 1 as posts, the electrical terminals 110 may take any other

form which is accessible from an exterior of the portable electrical energy storage device 106z, including electrical terminals positioned within slots in a battery housing. As the portable electrical energy storage devices 106 may be lent, leased, and/or rented out to the public, it is desirable to provide vehicle event data to the user of the vehicle in which portable electrical energy storage device 106z is currently being used, for example, for display on the user's mobile device or when the user exchanges or drops off portable electrical energy storage device 106z at a collection, charging and distribution machine 102. Systems and methods for providing vehicle event data are described in more detail below with reference to Figures 2-7, and are useful in the overall system for collection, charging and distribution of portable electrical energy storage devices 106 described herein.

The collection, charging and distribution machine 102 is positioned at some location 112 at which the collection, charging and distribution machine 102 is conveniently and easily accessible by various end users. The location may take any of a large variety of forms, for example, a retail environment such as a convenience store, supermarket, gas or petrol station, or service shop. Alternatively, the collection, charging and distribution machine 102 may stand alone at a location 112 not associated with an existing retail or other business, for example in public parks or other public places. Thus, for example, collection, charging and distribution machines 102 may be located at each store of a chain of convenience stores throughout a city or region. Such may advantageously rely on the fact that convenience stores are often sited or distributed based on convenience to the target population or demographic. Such may advantageously rely on pre-existing leases on storefronts or other retail locations to allow an extensive network of collection, charging and distribution machines 102 to be quickly developed in a city or region. Quickly achieving a large network which is geographically well distributed to serve a target population enhances the ability to depend on such a system and likely commercial success of such an effort.

The location 112 may include an electrical service 114 to receive electrical power from a generating station (not shown) for example via a grid 116. The electrical service 114 may, for example, include one or more of an

electrical service meter 114a, a circuit panel (e.g., circuit breaker panel or fuse box) 114b, wiring 114c, and electrical outlet 114d. Where the location 112 is an existing retail or convenience store, the electrical service 114 may be an existing electrical service, so may be somewhat limited in rating (e.g., 120 volts, 240  
5 volts, 220 volts, 230 volts, 15 amps).

Neither the operator of the retail location 112, nor the owner, distributor or operator of the collection, charging and distribution machine 102 may wish to bear the costs of upgrading the electrical service 114. Yet, quick charging is  
10 desired in order to maintain an adequate supply of portable electrical energy storage devices 106 available for use by end users. Optionally, the collection, charging and distribution machine 102 may include or be coupled to a source of renewable electrical power. For example, where installed in an outside location the collection, charging and distribution machine 102 may include an array of  
15 photovoltaic (PV) cells 118 to produce electrical power from solar insolation. Alternatively, the collection, charging and distribution machine 102 may be electrically coupled to a microturbine (e.g., wind turbine) or PV array positioned elsewhere at the location 112, for instance on a roof top or pole mounted at a top of a pole (not shown).

20 The collection, charging and distribution machine 102 may be communicatively coupled to one or more remotely located computer systems, such as back end or back office systems (only one shown) 120. The back end or back office systems 120 may collect data from and/or control a plurality of  
25 collection, charging and distribution machine 102 distributed about an area, such as a city. The communications may occur over one or more communications channels including one or more networks 122, or non-networked communications channels. Communications may be over one or more wired communications channels (e.g., twisted pair wiring, optical fiber), wireless  
30 communications channels (e.g., radio, microwave, satellite, 801.11 compliant). Networked communications channels may include one or more local area networks (LANs), wide area networks (WANs), extranets, intranets, or the Internet including the Worldwide Web portion of the Internet.

The collection, charging and distribution machine 102 may include a user interface 124. The user interface may include a variety of input/output (I/O) devices to allow an end user to interact with the collection, charging and distribution machine 102. Various I/O devices are called out and described in  
5 reference to Figure 2, which follows.

Figure 2 shows the collection, charging and distribution machine 102 of Figure 1, according to one illustrated embodiment.

10 The collection, charging and distribution machine 102 includes a control subsystem 202, a charging subsystem 204, a communications subsystem 206, and a user interface subsystem 208.

The control subsystem 202 includes a controller 210, for example a  
15 microprocessor, microcontroller, programmable logic controller (PLC), programmable gate array (PGA), application specific integrated circuit (ASIC) or another controller capable of receiving signals from various sensors, performing logical operations, and sending signals to various components. Typically, the controller 210 may take the form of a microprocessor (e.g., INTEL ATOM or  
20 ARM M3). The control subsystem 202 may also include one or more non-transitory processor- or computer-readable storage media, for example read only memory (ROM) 212, random access memory (RAM) 214, and data store 216 (e.g., solid-state storage media such as flash memory or EEPROM, spinning storage media such as hard disk). The non-transitory processor- or computer-  
25 readable storage media 212, 214, 216 may be in addition to any non-transitory storage medium (e.g., registers) which is part of the controller 210. The control subsystem 202 may include one or more buses 218 (only one illustrated) coupling various components together, for example one or more power buses, instruction buses, data buses, etc.

30 As illustrated, the ROM 212, or some other one of the non-transitory processor- or computer-readable storage media 212, 214, 216, stores instructions and/or data or values for variables or parameters. The sets of data may take a variety of forms, for example a lookup table, a set of records in a

database, etc. The instructions and sets of data or values are executable by the controller 110. Execution of the instructions and sets of data or values causes the controller 110 to perform specific acts to cause the collection, charging and distribution machine 102 to collect, charge, and distribute portable energy storage devices. Specific operation of the collection, charging and distribution machine 102 is described herein and also below with reference to various flow diagrams (Figures 5-7) in the context of being an external device to charge the portable electrical energy storage devices 106 and provide information based on vehicle event data received from the portable electrical energy storage devices 106.

The controller 210 may use RAM 214 in a conventional fashion, for volatile storage of instructions, data, etc. The controller 210 may use data store 216 to log or retain information, for example, vehicle event data received from the portable electrical energy storage devices 106 and telemetric information related to collection, charging and/or distribution or collection of the portable electric power storage devices 106 and/or operation of the collection, charging and distribution machine 102 itself. The instructions are executable by the controller 210 to control operation of the collection, charging and distribution machine 102 in response to end user or operator input, and using data or values for the variables or parameters.

The control subsystem 202 receives signals from various sensors and/or other components of the collection, charging and distribution machine 102 which include information that characterizes or is indicative of operation, status, or condition of such other components. Sensors are represented in Figure 2 by the letter S appearing in a circle along with appropriate subscript letters.

For example, one or more position sensors  $S_{P1}$ - $S_{PN}$  may detect the presence or absence of portable electrical power storage device 106 at each of the receivers 104. The position sensors  $S_{P1}$ - $S_{PN}$  may take a variety of forms. For example, the position sensors  $S_{P1}$ - $S_{PN}$  may take the form of mechanical switches that are closed, or alternatively opened, in response to contact with a portion of a respective portable electrical power storage device 106 when the portable

electrical power storage device 106 is inserted into the receiver 104, or contact with a memory device of the portable electrical power storage device 106. Also for example, the position sensors  $S_{P1}$ - $S_{PN}$  may take the form of optical switches (*i.e.*, optical source and receiver) that are closed, or alternatively opened, in response to contact with a portion of a respective portable electrical power storage device 106 when the portable electrical power storage device 106 is inserted into the receiver 104. Also for example, the position sensors  $S_{P1}$ - $S_{PN}$  may take the form of electrical sensors or switches that are closed, or alternatively opened, in response to detecting a closed circuit condition created by contact with the terminals 110 of a respective portable electrical power storage device 106 when the portable electrical power storage device 106 is inserted into the receiver 104, or an open circuit condition that results from the lack of a respective portable electrical power storage device 106 in the receiver 104. These examples are intended to be non-limiting, and it is noted that any other structures and devices for detecting the presence/absence or even the insertion of the portable electrical power storage devices 106 into receivers may be employed.

For example, one or more charge sensors  $S_{C1}$ - $S_{CN}$  may detect charge of the portable electrical power storage devices 106 at each of the receivers 104. Charge sensors  $S_{C1}$ - $S_{CN}$  may detect the amount of charge stored by the portable electrical power storage devices 106. Charge sensors  $S_{C1}$ - $S_{CN}$  may additionally detect an amount of charge and/or rate of charging being supplied to ones of the portable electrical power storage devices 106 at each of the receivers 104. Such may allow assessment of current (*i.e.*, temporal) charge condition or status of each portable electrical power storage device 106, as well as allow feedback control over charging of same, including control over rate of charging. Charge sensors  $S_{C1}$ - $S_{CN}$  may include any variety of current and/or voltage sensors.

For example, one or more charge sensors  $S_{T1}$  (only one shown) may detect or sense a temperature at the receivers 104 or in the ambient environment.

The control subsystem 202 provides signals to various actuators and/or other components responsive to control signals, which signals include information that characterizes or is indicative of an operation the component is to perform or a state or condition in which the components should enter. Control signals, actuators or other components responsive to control signals are represented in Figure 2 by the letter C appearing in a circle along with appropriate subscript letters.

For example, one or more engine control signals  $C_{A1}$ - $C_{AN}$  may affect the operation of one or more actuators 220 (only one illustrated). For instance, a control signal  $C_{A1}$  may cause movement of an actuator 220 between a first and a second position or change a magnetic field produced by the actuator 220. The actuator 220 may take any of a variety of forms, including but not limited to a solenoid, an electric motor such as a stepper motor, or an electromagnet. The actuator 220 may be coupled to operate a latch, lock or other retainer mechanism 222. The latch, lock or other retainer mechanism 222 may selectively secure or retain one or more portable electrical power storage devices 106 (Figure 1) in the receiver 104 (Figure 1). For instance, the latch, lock or other retainer mechanism 222 may physically couple to a complimentary structure that is part of a housing of the portable electrical power storage devices 106 (Figure 1). Alternatively, the latch, lock or other retainer mechanism 222 may magnetically couple to a complimentary structure that is part of a housing of the portable electrical power storage devices 106 (Figure 1). Also for instance, the latch, lock or other mechanism may open a receiver 104 (Figure 1), or may allow a receiver 104 to be opened, to receive a partially or fully discharged portable electrical power storage device 106 for charging. For example, the actuator may open and/or close a door to the receiver 104 (Figure 1), to selectively provide access to a portable electrical power storage device 106 (Figure 1) received therein. Also, for example, the actuator may open and/or close a latch or lock, allowing an end user to open and/or close a door to the receiver 104 (Figure 1), to selectively provide access to a portable electrical power storage device 106 (Figure 1) received therein.

The control subsystem 202 may include one or more ports 224a to provide control signals to one or more ports 224b of the charging subsystem 206. The ports 224a, 224b may provide bi-directional communications. The control subsystem 202 may include one or more ports 226a to provide control signals to one or more ports 226b of the user interface subsystem 208. The ports 226a, 226b may provide bi-directional communications.

The charging subsystem 204 includes various electrical and electronic components to charge portable electrical power storage devices 106 when positioned or received in the receivers 104. For example, the charging subsystem 204 may include one or more power buses or power bus bars, relays, contactors or other switches (e.g., insulated gate bipolar transistors or IGBTs, metal oxide semiconductor transistors or MOSFETs), rectifier bridge(s), current sensors, ground fault circuitry, etc. The electrical power is supplied via contacts that can take any of a variety of forms, for instance terminals, leads, posts, etc. The contacts allow electrical coupling of various components. Some possible implementations are illustrated in Figure 2. Such is not intended to be exhaustive. Additional components may be employed while other components may be omitted.

The illustrated charging subsystem 204 includes a first power converter 230 that receives electrical power from the electrical service 114 (Figure 1) via a line or cord 232. The power will typically be in the form of single, two or three phase AC electrical power. As such, the first power converter 230 may need to convert and otherwise condition the electrical power received via the electrical services 114 (Figure 1), for example for rectifying an AC waveform to DC, transforming voltage, current, phase, as well as reducing transients and noise. Thus, the first power converter 230 may include a transformer 234, rectifier 236, DC/DC power converter 238, and filter(s) 240.

The transformer 234 may take the form of any variety of commercially available transformers with suitable ratings for handling the power received via the electrical service 114 (Figure 1). Some embodiments may employ multiple transformers. The transformer 234 may advantageously provide galvanic

isolation between the components of the collection, charging and distribution machine 102 and the grid 116 (Figure 1). The rectifier 236 may take any of variety of forms, for example a full bridge diode rectifier or a switch mode rectifier. The rectifier 236 may be operated to transform AC electrical power to  
5 DC electrical power. The DC/DC power converter 238 may be any of a large variety of forms. For example, DC/DC power converter 238 may take the form a switch mode DC/DC power converter, for instance employing IGBTs or MOSFETs in a half or full bridge configuration, and may include one or more inductors. The DC/DC power converter 238 may have any number of topologies  
10 including a boost converter, buck converter, synchronous buck converter, buck-boost converter or fly-back converter. The filter(s) 240 may include one or more capacitors, resistors, Zener diodes or other elements to suppress voltage spikes, or to remove or reduce transients and/or noise.

15 The illustrated charging subsystem 204 may also receive electrical power from a renewable power source, for example the PV array 118 (Figure 1). Such may be converted or conditioned by the first power converter 230, for example being supplied directly to the DC/DC power converter 238, bypassing the transformer 236 and/or rectifier 236. Alternatively, the illustrated charging  
20 subsystem 204 may include a dedicated power converter to convert or otherwise condition such electrical power.

The illustrated charging subsystem 204 may optionally include second power converter 242 that receives electrical power from one or more portable  
25 electrical power storage devices 106 (Figure 1) via one or more lines 244, for charging other ones of the portable electrical power storage devices 106. As such, the second power converter 242 may need to convert and/or otherwise condition the electrical power received from portable electrical power storage devices 106, for example optionally transforming voltage or current, as well as  
30 reducing transients and noise. Thus, the second power converter 242 may optionally include a DC/DC power converter 246 and/or filter(s) 248. Various types of DC/DC power converters and filters are discussed above.

**APPARATUS, METHOD AND ARTICLE  
FOR PROVIDING VEHICLE EVENT DATA**

SEARCHED  
SERIALIZED  
INDEXED  
FILED  
OCT 14 1985  
FBI - MEMPHIS

**BACKGROUND**

5

Technical Field

The present disclosure generally relates to providing data and, more particularly, to providing vehicle event data, which may be suitable for use in a variety of fields or applications, for instance transportation and non-transportation uses.

10

Description of the Related Art

There are a wide variety of uses or applications for portable electrical power storage devices.

15

One such application is in the field of transportation. Hybrid and all electrical vehicles are becoming increasingly common. Such vehicles may achieve a number of advantages over traditional internal combustion engine vehicles. For example, hybrid or electrical vehicles may achieve higher fuel economy and may have little or even zero tail pipe pollution. In particular, all electric vehicles may not only have zero tail pipe pollution, but may be associated with lower overall pollution. For example, electrical power may be generated from renewable sources (e.g., solar, hydro). Also for example, electrical power may be generated at generation plants that produce no air pollution (e.g., nuclear plants). Also for example, electrical power may be generated at generation plants that burn relatively "clean burning" fuels (e.g., natural gas), which have higher efficiency than internal combustion engines, and/or which employ pollution control or removal systems (e.g., industrial air scrubbers) which are too large, costly or expensive for use with individual vehicles.

20

25

30

Personal transportation vehicles such as combustion engine powered scooters and/or motorbikes are ubiquitous in many places, for example in the many large cities of Asia. Such scooters and/or motorbikes tend to be relatively

The illustrated charging subsystem 204 includes a plurality of switches 250 responsive to the control signals delivered via ports 224a, 224b from the control subsystem 202. The switches may be operable to selectively couple a first number or set of portable electrical power storage devices 106 to be charged from electrical power supplied by both the electrical service via the first power converter 230 and from electrical power supplied by a second number or set of portable electrical power storage devices 106. The first number or set of portable electrical power storage devices 106 may include a single portable electrical power storage device 106, two, or even more portable electrical power storage devices 106. The second number or set of portable electrical power storage devices 106 may include a single portable electrical power storage device 106, two, or even more portable electrical power storage devices 106. The portable electrical power storage devices 106 are represented in Figure 2 as loads  $L_1, L_2-L_N$ .

The communications subsystem 206 may additionally include one or more communications modules or components which facilitate communications with the various components of a back end or back office system 120 (Figure 1) and/or various components of the portable electrical power storage devices 106. The communications subsystem 206 may, for example, include one or more modems 252 or one or more Ethernet or other types of communications cards or components 254. A port 256a of the control subsystem 202 may communicatively couple the control subsystem 202 with a port 256b of the communications subsystem 206. The communications subsystem 206 may provide wired and/or wireless communications. For example, the communications subsystem 206 may provide components enabling short range (e.g., via Bluetooth, near field communication (NFC), radio frequency identification (RFID) components and protocols) or longer range wireless communications (e.g., over a wireless LAN, satellite, or cellular network) with various other devices external to the collection, charging and distribution machine 102, including the portable electrical energy storage devices 106. The communications subsystem 206 may include one or more ports, wireless receivers, wireless transmitters or wireless transceivers to provide wireless signal paths to the various remote components or systems. The remote

communications subsystem 206 may include one or more bridges or routers suitable to handle network traffic including switched packet type communications protocols (TCP/IP), Ethernet or other networking protocols.

5           The user interface system 208 includes one or more user input/output (I/O) components. For example, user interface system 208 may include a touch screen display 208a, operable to present information and a graphical user interface (GUI) to an end user and to receive indications of user selections. The user interface system 208 may include a keyboard or keypad 208b, and/or a  
10           cursor controller (e.g., mouse, trackball, trackpad) (not illustrated) to allow an end user to enter information and/or select user selectable icons in a GUI. The user interface system 208 may include a speaker 208c to provide aural messages to an end user and/or a microphone 208d to receive spoken user input such as spoken commands.

15           The user interface system 208 may include a card reader 208e to read information from card type media 209. The card reader 208e may take a variety of forms. For instance, the card reader 208e may take the form of, or include, a magnetic stripe reader for reading information encoded in a magnetic stripe  
20           carried by a card 209. For instance, the card reader 208e may take the form of, or include, a machine-readable symbol (e.g., barcode, matrix code) card reader for reading information encoded in a machine-readable symbol carried by a card 209. For instance, the card reader 208e may take the form of, or include, a smart card reader for reading information encoded in a non-transitory medium carried  
25           by a card 209. Such may, for instance, include media employing radio frequency identification (RFID) transponders or electronic payment chips (e.g., near field communications (NFC) chips). Thus, the card reader 208e may be able to read information from a variety of card media 209, for instance credit cards, debit cards, gift cards, prepaid cards, as well as identification media such as drivers  
30           licenses. The card reader 208e may also be able to read information encoded in a non-transitory medium carried by the portable electrical energy storage devices 106, and may also include RFID transponders, transceivers, NFC chips and/or other communication devices to communicate information to the portable electrical energy storage devices 106 (e.g., for authentication of the portable

electrical energy storage devices 106 and/or authentication of the collection, charging and distribution machine 102 to the portable electrical energy storage devices 106).

5           The user interface system 208 may include a bill acceptor 208f and a validator and/or coin acceptor 208g to accept and validate cash payments. Such may be highly useful in servicing populations who lack access to credit. Bill acceptor and validator 208f and/or coin acceptor 208g may take any variety of forms, for example those that are currently commercially available and used in  
10 various vending machines and kiosks.

Figure 3A is a block diagram of a system for providing vehicle event data which shows collection, charging and distribution machines 308a to 308d, such as that of Figure 1, within the system, according to one non-limiting illustrated  
15 embodiment.

Shown is a vehicle data information management system 302 for providing vehicle event data via a mobile device, such as, for example, mobile device 313. For example, the vehicle data information management system 302  
20 may provide information regarding one or more of: an accident involving the vehicle, an emergency involving the vehicle, a breakdown of the vehicle, a catastrophic failure of the vehicle, a signal from a tilt sensor, a signal from a gravity sensor, a signal from an accelerometer, a signal from a shock sensor, temperature of the vehicle or vehicle components, temperature of a battery of  
25 the vehicle, temperature of a motor of the vehicle, temperature of an electronic component of the vehicle, data, signal or information from a temperature sensor, data, signal or information from a battery temperature sensor, dangerous temperature levels, temperature levels over or under one or more threshold temperatures, dangerous driving behavior, and one or more types of driving  
30 behaviors, etc. Such sensors may be located in or attached to the portable electrical energy storage device of the vehicle (e.g., vehicle 310a) or other locations in the vehicle. Once generated by such sensors, this information may be communicated to and/or received from one or any combination of the items shown in Figure 3, including the example collection, charging and distribution

machines 308a, 308b, 308c and 308d, the mobile device 313 itself, the vehicle data information management system 302, and/or the vehicle (e.g., electric scooter 310a or 310b).

5           This may include information received from a memory module attached to the portable electrical energy storage device of the electric scooter 310a or 310b (see Figure 3B). This also may include information received from a memory module attached to or associated with the vehicle 310a or 310b, (e.g., a memory module of a subsystem or control system of vehicle 310a or 310b that  
10 stores or is configured to store vehicle event data and possibly other information, etc.). For example, this may include information received from or stored in any memory module storing or configured to store at least some information regarding one or more of: an accident involving the vehicle, an emergency involving the vehicle, a breakdown of the vehicle, a catastrophic failure of the  
15 vehicle, a signal from a tilt sensor, a signal from a gravity sensor, a signal from an accelerometer, a signal from a shock sensor, temperature of the vehicle or vehicle components, temperature of a battery of the vehicle, temperature of a motor of the vehicle, temperature of an electronic component of the vehicle, data, signal or information from a temperature sensor, data, signal or information  
20 from a battery temperature sensor, dangerous temperature levels, temperature levels over or under one or more threshold temperatures, dangerous driving behavior, and one or more types of driving behaviors, etc.

          This information above may be received directly or indirectly from such a  
25 memory module described above. For example, this information may be received by a memory module attached to the portable electrical energy storage device of the electric scooter 310a from one or more systems of vehicle 310a and/or other memory module as described above (including, but not limited to: such a memory module of the user mobile device 313; of one or more collection,  
30 charging and distribution machines 308a-308d, of the vehicle data information management system 302, of another vehicle 310b, etc.). This information may also be received indirectly from the memory module via any one of the communication systems of the items in the system 300 shown in Figure 3. For example, the data regarding the vehicle 310a described herein may be

communicated to, stored in and communicated from the memory module, or the like, in the diagnostic data storage system attached to the portable electrical energy storage device of vehicle 310a as described in U.S. Provisional Patent Application Serial No. 61/601,404 entitled "APPARATUS, METHOD AND ARTICLE FOR PROVIDING VEHICLE DIAGNOSTIC DATA" and filed on February 21, 2012, and/or described in U.S. Patent Application Serial No. 13/559,390 also entitled "APPARATUS, METHOD AND ARTICLE FOR PROVIDING VEHICLE DIAGNOSTIC DATA" and filed on July 26, 2012, both of which are hereby incorporated by reference in their entireties. In some embodiments, the vehicle data information management system 302, or parts or subcomponents thereof, may be the back end or back office system 120 shown in Figure 1. In other embodiments, the vehicle data information management system 302 may be part of or may be in operable communication with, the back end or back office system 120 shown in Figure 1.

The vehicle data information management system 302 is in operable communication with the collection, charging and distribution machines 308a, 308b, 308c and 308d, and one or more user mobile communication devices 313 (only one shown as an example), such that data may be exchanged between the vehicle data information management system 302, the collection, charging and distribution machines 308a, 308b, 308c and 308d, and the user mobile communication device 313. In some embodiments, such exchange of data may be accomplished via storage of such data on a memory module attached to a portable electrical energy storage device used by the vehicle which is exchanged at one or more of collection, charging and distribution machines 308a, 308b, 308c and 308d (see Figure 3B). Also, the vehicle data information management system 302, the collection, charging and distribution machines 308a, 308b, 308c and 308d, and the user mobile communication device 313 may, in some embodiments, additionally or instead be in operable communication directly with each other.

This communication between the various items, systems and entities of Figure 3A is enabled by the various communications subsystems of these various items, systems and entities. For example, this communication may be

enabled by the various communications subsystems of the distribution machines 308a, 308b, 308c and 308d, the vehicle data information management system 302, the vehicles 310a and 310b, and the user mobile communications device 313. One or more of such communication subsystems may provide wired and/or  
5 wireless communications (e.g., cellular, local area network connections, and/or short range wireless connections using or being compatible with any operable communications protocol and/or standard). The communications subsystems of the items in Figure 3A may include one or more ports, wireless receivers, wireless transmitters or wireless transceivers to provide wireless signal paths to  
10 the various remote components or systems. The remote communications subsystems may include one or more bridges or routers suitable to handle network traffic including switched packet type communications protocols (TCP/IP), Ethernet or other networking protocols.

15 For example, the vehicle data information management system 302 may receive an update from collection, charging and distribution machine 308c regarding an event involving the vehicle (e.g., an accident or impact) of the vehicle and/or usage history of the vehicle. In some embodiments, the vehicle data information management system 302 may continually or periodically  
20 monitor the collection, charging and distribution machines or other items shown in Figure 3 to obtain such information. Also, the collection, charging and distribution machines may continually or periodically provide updates to the vehicle data information management system 302 regarding the vehicle event data. This information may be provided to mobile device 313, vehicle 310a,  
25 and/or vehicle 310b continuously, periodically, aperiodically and/or or in response to a request for such information from mobile device 313, vehicle 310a, and/or vehicle 310b. For example, vehicle event data regarding vehicle 310a may be provided to mobile device 313 and/or vehicle 310a in response to the mobile device 313 or vehicle 310a being detected by the vehicle data information  
30 management system 302, or by collection, charging and distribution machine 308a, as being within close proximity to collection, charging and distribution machine 308a.

An alert may be sent to the mobile device 313 or vehicle 310a (e.g., via a text message, email, instant message, status update on a social media network, automated phone call, as a notification within a specific application, etc.) regarding an event involving vehicle (e.g., an accident or impact) etc., based on  
5 the vehicle event data. This alert may be sent via any variety of communications channels including, but not limited to, cellular telephone networks, computer wireless fidelity (Wi-Fi) networks, satellite networks, short range wireless signals, etc., or any operable combination thereof.

10 The alert may also include a selectable link, icon or other user interface element that the user may select to receive further information regarding what to do in case of an event such as the one detected based on the vehicle event data or otherwise act on the information communicated in the alert. For example,  
15 information regarding, a link to, or contact information regarding emergency services, towing services, insurance services, police, and/or vehicle or portable electrical energy storage device replacement or repair may be provided. This information or access thereto may be stored in a database maintained centrally by the vehicle data information management system 302 and/or locally at the selected collection, charging and distribution machine.

20 Any item of Figure 3 may identify, authenticate, verify or otherwise facilitate such operations via the user interface of the vehicle, the mobile device, and/or or collection, charging and distribution machine by the user inputting particular user credentials, a password, biometric data, a user identification  
25 number or code, and/or by the card reader 208e described above, etc. Also, any item of Figure 3 may additionally or alternatively identify, authenticate, verify or otherwise facilitate such operations via information received from a user security token (not shown), mobile device 313 or other item associated with the user. The vehicle event data may be communicated and organized in any manner  
30 including in a list, as a group of selectable icons, etc., that indicates information based on the vehicle data.

In some embodiments, various options and features regarding available portable electrical energy storage devices may be generated and made available

to the user. For example, a specific user's, a specific vehicle's and/or a specific portable electrical energy storage device's safety record may be determined, stored and/or communicated based on the corresponding vehicle event data aggregated by the vehicle data information management system 302. The communication of the events and types of events may be logged and automatically aggregated by the vehicle data information management system 302 from multiple vehicles (e.g., scooters 310a and 310b) for further analysis to determine various potential system-wide safety issues and to track event history on an individual per-user or individual per-vehicle basis or individual per-portable electrical energy storage device basis. Event history, statistics and related alerts may also be communicated wirelessly back to the user (e.g., to mobile device 310a) and displayed on the user's mobile device and/or scooter dash display (e.g., the dash display of scooter 310a). The same information may also be communicated wirelessly to a collection, charging and distribution machine (e.g., collection, charging and distribution machine 308a) and displayed on the collection, charging and distribution machine display. Such information may also be transferred accordingly via the portable electrical energy storage device exchange process at the online collection, charging and distribution machine (e.g., collection, charging and distribution machine 308a) through a memory device attached to the portable electrical energy storage device that stores the event data (e.g., see Figure 3B).

Figure 3B is a block diagram of the portable electrical energy storage device 106z of Figure 1, according to one non-limiting illustrated embodiment.

Shown is a portable electrical energy storage device housing 320, electrical terminals 110a, 110b, a battery cell 304, event data storage system 306, a secure access panel 314 and an event data storage system connection port 318. The battery cell 304 is any rechargeable type of electrochemical cell that converts stored chemical energy into electrical energy. As described above, the electrical terminals 110a, 110b are accessible from an exterior of the portable electrical energy storage device 106z. The electrical terminals 110 allow charge to be delivered from the portable electrical energy storage device 106z, as well as allow charge to be delivered to the portable electrical energy storage

device 106z for charging or recharging the same through conductive terminal connections 312a and 312b to the battery cell 304. While illustrated in Figure 3B as posts, the electrical terminals 110a and 110b may take any other form which is accessible from an exterior of the portable electrical energy storage device  
5 106z, including electrical terminals positioned within slots in the battery housing 320.

The event data storage system 306 is attached (fixedly or removably) directly or indirectly to an interior of the housing 320 and is operably coupled to  
10 the event data storage system connection port 318 via communications line 316 which travels through the housing 320 to the system connection port 318 that is accessible from the exterior of the portable electrical energy storage device 106z. The communications line 316 is configured to receive vehicle event data from external sources (*e.g.*, a vehicle event detection system) through the event  
15 data storage system connection port 318 and communicate such data to the event data storage system 306 for storage in the event data storage system 306. For example, the communications line 316 is configured to receive vehicle event data from a vehicle while the portable electrical energy storage device 106z is operably installed in the vehicle. In other embodiments, the communications line  
20 316 is configured to receive vehicle event data from a vehicle while the portable electrical energy storage device 106z is not operably installed in the vehicle. For example, the portable electrical energy storage device 106z may be connected via communications line 316 to an event detection system of the vehicle and be able to receive event data from the vehicle, while the electrical terminals 110 of  
25 the portable electrical energy storage device 106z are not operably connected to the vehicle (such as when the portable electrical energy storage device 106z is in the process of being installed or uninstalled, or is placed in the vehicle temporarily for the purpose of downloading vehicle event data, but not for powering the vehicle).

30 Such event data includes, but is not limited to, information regarding one or more of: an accident involving the vehicle, an emergency involving the vehicle, a breakdown of the vehicle, a catastrophic failure of the vehicle, a signal from a tilt sensor, a signal from a gravity sensor, a signal from an accelerometer,

a signal from a shock sensor, temperature of the vehicle or vehicle components, temperature of a battery of the vehicle, temperature of a motor of the vehicle, temperature of an electronic component of the vehicle, data, signal or information from a temperature sensor, data, signal or information from a battery  
5 temperature sensor, dangerous temperature levels, temperature levels over or under one or more threshold temperatures, dangerous driving behavior, and one or more types of driving behaviors.

The event data storage system connection port 318 may be operably  
10 connected to a vehicle event detection system, an event detection system of the portable electrical energy storage device 106z, sensors of the vehicle and/or portable electrical energy storage device 106z (e.g., a tilt sensor, a gravity sensor, an accelerometer, a shock sensor, etc.) or may be configured to be operably connected to any number of vehicle subsystems configured to output  
15 event data regarding the particular corresponding vehicle subsystem. The event data storage system connection port 318 is configured to be compatible with one or more output ports of the respective vehicle event detection system or vehicle subsystem to which it is connected. In some embodiments, the event data storage system connection port 318 is operably coupled to a vehicle event  
20 detection system (e.g., the vehicle event detection system 418 shown in Figure 4) as the portable electrical energy storage device 106z is operably placed or installed in the vehicle. For example, the event data storage system connection port 318 may be positioned on the exterior of the portable electrical energy storage device 106z housing 320 such that it aligns and connects with a  
25 corresponding output port of the vehicle event detection system 418 (shown in Figure 4) when the portable electrical energy storage device 106z is properly placed or installed in the vehicle. The communications line 316 is also configured to send vehicle event data to external sources (e.g., a portable electrical energy storage device collection, charging and distribution machine 102, a mobile  
30 device, a server, etc.) from the event data storage system 306 through the event data storage system connection port 318.

The event data storage system 306 is operably coupled to the battery cell 304 via one or more power lines 322 in a manner such that the event data

inexpensive, particularly as compared to automobiles, cars or trucks. Cities with high numbers of combustion engine scooters and/or motorbikes also tend to be very densely populated and suffer from high levels of air pollution. When new, many combustion engine scooters and/or motorbikes provide a relatively low  
5 polluting source of personal transportation. For instance, such scooters and/or motorbikes may have higher mileage ratings than larger vehicles. Some scooters and/or motorbikes may even be equipped with basic pollution control equipment (e.g., catalytic converter). Unfortunately, factory specified levels of emission are quickly exceeded as the scooters and/or motorbikes are used and either not  
10 maintained and/or as the scooters and/or motorbikes are modified, for example by intentional or unintentional removal of catalytic converters. Often owners or operators of scooters and/or motorbikes lack the financial resources or the motivation to maintain their vehicles.

15 It is known that air pollution has a negative effect on human health, being associated with causing or exacerbating various diseases (e.g., various reports tie air pollution to emphysema, asthma, pneumonia, cystic fibrosis as well as various cardiovascular diseases). Such diseases take large numbers of lives and severely reduce the quality of life of countless others.

20

#### BRIEF SUMMARY

A vehicle event data processing system may be summarized as comprising at least one controller and at least one memory device configured to be coupled to the at least one controller. The at least one controller may receive  
25 event data regarding the vehicle and store at least some of the event data in the memory device. The at least one controller may communicate at least some of the event data for display on a device. The at least one memory device may be configured to be coupled to the at least one controller when a portable electrical energy storage device is operably placed in the vehicle. The at least one  
30 controller may be attached to the electrical energy storage device. The device may be mobile device or a dashboard display of a vehicle, for example.

The at least one controller may be further configured to receive the event data regarding the vehicle from a vehicle event detection system of the vehicle.

storage system 306 may receive power for operation of the event data storage system 306 to store vehicle event data. In other embodiments, the event data storage system 306 may receive power from other external sources or may be a system which does not require its own power to store the event data.

5

The access panel 314 is located on the housing 320 and is configured to provide access to the event data storage system 306 for inspection, diagnosis, replacement, and/or repair of the event data storage system 306 and/or any components of the event data storage system 306. The access panel 314 may also include a lock, be tamper resistant or include other security elements to limit access to the event data storage system 306. The access panel 314 may also include weather proofing components such as a seal or other protective components to protect the event data storage system 306 from external elements. In other embodiments, the event data storage system 306 may instead be fixedly or removably attached to an exterior of the housing 320. In such instances, the communications line would not travel through the housing 320. However, in such embodiments, the power line 322 to the battery cell 304, if present, would travel through the housing 320.

20

In some embodiments, the event data storage system 306 is configured to receive and/or send vehicle event data wirelessly to or from an external device. For example, the event data storage system 306 may be configured to receive vehicle event data wirelessly from the vehicle or external event detection system and/or send stored vehicle event data wirelessly to the portable electrical energy storage device collection, charging and distribution machine 102 or other remote device, such as a portable computer or smartphone. In such embodiments, the communications line 316 and the event data storage system connection port 318 may or may not be present as the event data storage system 306 may be configured to send and/or receive vehicle event data wirelessly instead of, or in addition to, being configured to send and/or receive vehicle event data via the communications line 316 and the event data storage system connection port 318.

25

30

The housing 320 is constructed of a polymer or other durable material of sufficient thickness to protect the battery cell 304 and event data storage system 306 from outside elements and tampering. For example the walls of the housing may be at least approximately .25 inch thick and completely surround the battery cell 304 and event data storage system 306 (except for, in some embodiments, a small vent hole in the housing) such that the battery cell 304 and event data storage system 306 cannot be accessed without a key or other specialized tool to open the locked access panel 314.

The housing 320 may provide a protection to prevent or deter tampering, and may be formed of suitably strong and resilient materials (e.g., ABS plastic). Such may not only prevent or deter tampering, but may leave a visible indication of any tampering attempts. For example, the housing 320 may include a strong outer layer of a first color (e.g., black) within an inner layer of a second color (e.g., fluorescent orange) there beneath. Such will render attempts to cut through the housing 320 visibly apparent.

Figure 4A is a schematic view of the event data storage system 306 of Figure 3B coupled to a vehicle event detection system 418, according to one non-limiting illustrated embodiment.

The event data storage system 306 includes a controller 410, a communications subsystem 406, read only memory (ROM) 412, random access memory (RAM) 414 and other storage 416.

The controller 410, for example is a microprocessor, microcontroller, programmable logic controller (PLC), programmable gate array (PGA), application specific integrated circuit (ASIC) or another controller capable of receiving signals from various sensors, performing logical operations, and sending signals to various components. Typically, the controller 410 may take the form of a microprocessor (e.g., INTEL, AMD, ATOM). The event data storage system 306 may also include one or more non-transitory processor- or computer-readable storage media, for example read only memory (ROM) 412, random access memory (RAM) 414, and other storage 416 (e.g., solid-state

storage media such as flash memory or EEPROM, spinning storage media such as hard disk). The non-transitory processor- or computer-readable storage media 412, 414, 416 may be in addition to any non-transitory storage medium (e.g., registers) which is part of the controller 410. The event data storage system 306 may include one or more buses 419 (only one illustrated) coupling various components together, for example one or more power buses, instruction buses, data buses, etc.

As illustrated, the ROM 412, or some other one of the non-transitory processor- or computer-readable storage media 412, 414, 416, stores instructions and/or data or values for variables or parameters. The sets of data may take a variety of forms, for example a lookup table, a set of records in a database, etc. The instructions and sets of data or values are executable by the controller 410. Execution of the instructions and sets of data or values causes the controller 410 to perform specific acts to cause the event data storage system 306 to receive, store and send vehicle event data, such as data received from the vehicle event detection system. The event data may be stored in one or more of the ROM 412, RAM 414 and other storage 416 in a variety of forms and formats including, but not limited to a lookup table, a set of records in a database, etc. The event data may be stored in a format, or converted to and then stored in a format in compliance with a standard format for vehicle event data or other format compatible or readable by various external devices. Information, including event data, could be stored initially at full fidelity, and then incrementally compressed as memory space becomes less. In some embodiments, diagnostically, the vehicle event data information management system 302 or other service center, such as that using the back end or back office systems 120, might require detailed collection of data at a specified interval. For example, the vehicle event data information management system 302 could know that a certain batch of motors was potentially made with a manufacturing defect that causes excessive vibration after some time. The vehicle event data information management system 302 could trace those motors to particular vehicles and request the accelerometer of those vehicles to collect the data at a rate suitable to determine if that particular vehicle was suffering from this early wear mechanism. The vehicle event data information

management system 302 can request collection of certain types of data by the vehicle with selectable parameters (such as sampling rate) to aid in in-field diagnostics. Alternately, a government might request information on road quality using such a mechanism.

5

Also, various metadata related to the event data may also be stored in one or more of the ROM 412 and other storage 416, including but not limited to: associations or indications of associations of the event data with a particular vehicle, portable electrical energy storage device and/or user; date and time information associated with particular event data, vehicle information associated with the event data, categories or types of the event data, vehicle part information associated with parts needing replaced based on the event data, etc. Specific operation of the event data storage system 306 is described herein and also below with reference to various flow diagrams (Figures 5-7).

15

The controller 410 may use RAM 414 in a conventional fashion, for volatile storage of instructions, data, etc. The controller 410 may use data store 416 to log or retain vehicle event data, information regarding route information of user, historic data, etc. The instructions are executable by the controller 410 to control operation of the event data storage system 306 in response to input from remote and/or external systems such as those of external devices including but not limited to: the vehicle event detection system 418; charging devices; vehicles; user identification devices (cards, electronic keys, etc.); portable electrical energy device collection, charging and distribution machines; collection, charging and distribution machine service systems; user mobile devices; user vehicles; and end user or operator input.

20

25

The controller 410 may also receive signals from various sensors and/or components of an external device via the communications subsystem 206 of collection, charging and distribution machine 102. This information may include information that characterizes or is indicative of the authenticity, authorization level, operation, status, or condition of such components.

30

The communications subsystem 406 may include one or more communications modules or components which facilitates communications with the various components of external devices (e.g., such as to receive vehicle event data from the vehicle event detection system 418) and also the various components of the collection, charging and distribution machine 102 of Figure 1 (e.g., such as to send vehicle event data) and one or more user mobile communication devices, such that data may be exchanged between the devices for authentication purposes. Such event data, software updates and data updates of user profile and/or vehicle profile information may include information received from or originating from (either directly or indirectly) an external device or system (e.g., a user's mobile device) or from other external systems such as via, collection charging and distribution machines, collection charging and distribution machine managements systems, other network nodes or locations, etc. These instructions and/or other data may include information that may be used to automatically adjust settings of the vehicle or make other modifications to the vehicle by the vehicle event detection system or other vehicle system when the corresponding electrical energy storage device is placed in or is in (or at which point it becomes in) communication with the vehicle via the communications subsystem 406.

The communications subsystem 406 may provide wired and/or wireless communications. The communications subsystem 406 may include one or more ports, wireless receivers, wireless transmitters or wireless transceivers to provide wireless signal paths to the various remote components or systems. The communications subsystem 406 may, for example, include components enabling short range (e.g., via Bluetooth, near field communication (NFC), radio frequency identification (RFID) components and protocols) or longer range wireless communications (e.g., over a wireless LAN, satellite, or cellular network) and may include one or more modems or one or more Ethernet or other types of communications cards or components for doing so. For wired communications, one example embodiment may include the communications subsystem 406 being configured to multiplex and communicate information over power lines of the vehicle 310a. In some embodiments which include wired communications, the physical layer transport for the wired communications may be implemented

according to or based on the Society of Automotive Engineers' (SAE) J2931/3 specification (*i.e.*, the J2931/3 standard). The SAE J2931/3 specification is generally intended to enable communication from an electric vehicle to service equipment such as a car charger via the charging cable. In one example  
5 embodiment, the J2931/3 standard, or other suitable standard, may be applied to communication of information from the Vehicle Event Data Storage System 306 of the portable electrical energy storage device 106z to the dashboard display of the vehicle 310a and/or mobile device 313 when the mobile device is plugged in  
10 the vehicle for charging without adding new wires. The communications subsystem 406 may include connections to one or more bridges or routers suitable to handle network traffic including switched packet type communications protocols (TCP/IP), Ethernet or other networking protocols.

The controller 410 may be also configured to receive information  
15 regarding the vehicle and/or user with which the vehicle event detection system 418 is associated and store the received event data accordingly. For example, event data for a variety of particular vehicles may be stored in ROM 412 by the processor and associated with the corresponding vehicle in metadata stored in ROM 412. The controller 410 may be configured to receive requests for the  
20 event data from various external devices, and in response, provide such requested data, or indicate that such data is not available. In some embodiments, the controller 410 may be configured to perform search, edit, sort, delete and other database functionalities to manage the stored vehicle event data and identify and retrieve particular requested vehicle event data.

25  
The controller 410 may be configured to identify or authenticate various external devices before providing such vehicle event data by verifying codes, credentials or other information received from external devices with stored information. In some embodiments, the controller and/or communications  
30 subsystem 406 is configured to encrypt and/or decrypt information communicated between the event data storage system 306 and external devices (*e.g.*, between the event data storage system 306 and the portable electrical energy storage device collection, charging and distribution machine 102 or user mobile device). In some embodiments, the vehicle event data storage system

306 may optionally include cryptographic hardware operably coupled to the controller 410 that can maintain keys, encrypt information and provide secure hashing functions. For example, cryptographic hardware can optionally encrypt and/or sign data with public keys from other entities or from itself. The  
5 cryptographic hardware may securely store keys in a tamper-proof fashion. This ensures that sensitive data can be moved securely between the vehicle 310a and any of the collection, charging and distribution machines 308a to 308c, for example, via the portable electrical energy storage device 106z when it is placed in any one of the collection, charging and distribution machines 308a to 308c.  
10 In this manner, the sensitive data is not susceptible to modification or inspection by an external entity unless authorized. This allows, for example, a remote server, such as the vehicle event data information system 302 or other remote server to use its private key and the public key of the vehicle 310a to change configurations on the vehicle 310a, which might include sensitive information  
15 related to subscription and access to value-added services.

In some embodiments, some of the components of the event data storage system 306 shown in Figure 4A may not be present or may be located outside the event data storage system 306. For example, in some embodiments,  
20 the event data storage system 306 may comprise a memory device such as the ROM 412 configured to store vehicle event data while the other components shown in Figure 4A (e.g., the controller 410 and communications subsystem 406) are not present or are located outside the event data storage system 306 (e.g., are instead part of the vehicle event detection system 418).

25  
The vehicle event detection system 418 may be one or more event detection systems of a vehicle and/or portable electrical energy storage device and is configured to track and/or store and communicate vehicle event data. The vehicle event detection system 418 may include one or more sensors to detect  
30 events involving the vehicle and/or portable electrical energy storage device including, but not limited to, one or more of: a tilt sensor, a gravity sensor, an accelerometer, a shock sensor, etc. Such event data includes, but is not limited to, information regarding one or more of: an accident involving the vehicle, an emergency involving the vehicle, a breakdown of the vehicle, a catastrophic

failure of the vehicle, a signal from a tilt sensor, a signal from a gravity sensor, a signal from an accelerometer, a signal from a shock sensor, temperature of the vehicle or vehicle components, temperature of a battery of the vehicle, temperature of a motor of the vehicle, temperature of an electronic component of the vehicle, data, signal or information from a temperature sensor, data, signal or information from a battery temperature sensor, dangerous temperature levels, temperature levels over or under one or more threshold temperatures, dangerous driving behavior, and one or more types of driving behaviors.

10           The power line 322 is configured to provide power for operation of one or more of the various components of the event data storage system including the controller 410, a communications subsystem 406, read only memory (ROM) 412, random access memory (RAM) 414 and other storage 416. For example, the power line 322 may be operably coupled to a power source such as the battery cell 304 of the portable electrical energy storage device 106z (as shown in Figure 3B) and/or another power source located in the vehicle.

20           Figure 4B is an illustration of example information displayed on a user interface screen 420 regarding vehicle event data received from the event data storage system 306 of Figure 3B and Figure 4A, according to one non-limiting illustrated embodiment.

25           For example, the information shown in figure 4B may be displayed on a user interface screen of the user's mobile device 310a, the vehicle dashboard display of the user's vehicle (e.g., vehicle 310a) and/or on the display of the portable electrical energy storage device collection, charging and distribution machine 102 after the user places the portable electrical energy storage device 106z in the portable electrical energy storage device collection, charging and distribution machine 102. In one embodiment, once the user places the portable electrical energy storage device 106z in the portable electrical energy storage device collection, charging and distribution machine 102, a connection is established between the portable electrical energy storage device collection, charging and distribution machine 102 and the portable electrical energy storage device 106z (wirelessly and/or via the via the event data storage system

connection port 318). The portable electrical energy storage device collection, charging and distribution machine 102 then reads vehicle event data stored on the event data storage system 306 of the portable electrical energy storage device 106z and provides information regarding the event data to the user.

5 Figure 4B shows one example of providing such information regarding the event data read from the event data storage system 306 of the portable electrical energy storage device 106z. For example, shown in Figure 4B is a vehicle event report displaying a report regarding the event detected and a series of prompts 426 to make sure the user is not injured and regarding the vehicle condition to  
10 assess what further information to provide to the user. This information is provided based on the event data read from the vehicle accelerometer indicating an impact had occurred. Different or additional information may be displayed based on the degree or severity of impact detected. Additional related information may be provided including, but not limited to: information that may be  
15 useful in resolving an identified potential problem, instructional information regarding resolving an identified problem, location information of where to locate replacement vehicle parts, emergency services contact information, emergency dispatch service information, time remaining until emergency services arrive, etc. Also shown is a selectable button or icon 428 that the user may select to  
20 acknowledge the user has seen the information and to continue to a next screen or quit.

The information shown in Figure 4B may be displayed on a screen of the portable electrical energy storage device collection, charging and distribution  
25 machine 102 or otherwise communicated to a user as part of, or independently from, the process of exchanging or returning a portable electrical energy storage device 106z at the portable electrical energy storage device collection, charging and distribution machine 102 by the user. For example, a user may stop at the portable electrical energy storage device collection, charging and distribution  
30 machine 102 solely to check on the status or condition of the vehicle by obtaining information regarding the vehicle event data stored on the event data storage system 306 without needing to exchange, drop off or even remove the portable electrical energy storage device 106z from the vehicle in some embodiments (such as in embodiments where the vehicle event data is

communicated wirelessly from the event data storage system 306 to the portable electrical energy storage device collection, charging and distribution machine 102).

5           In some embodiments, the information shown in Figure 4B may be displayed on a user interface screen 420 of a mobile device of a user associated with the vehicle currently using (or that had previously used) the portable electrical energy storage device 106z. For example, once within wireless communications range of the event data storage system 306, the event data  
10 storage system 306 may authenticate the wireless mobile device and automatically push the stored vehicle event data to the mobile device or upon request from the mobile device for the vehicle event data. The event data storage system 306 may also authenticate the user associated with the mobile device as being a user associated with the vehicle and/or the event data storage  
15 system 306. For example, such authentication information regarding the association of the user with the vehicle and/or the event data storage system 306 may be communicated to the event data storage system 306 from the portable electrical energy storage device collection, charging and distribution machine 102 when the portable electrical energy storage device 106z having the  
20 event data storage system 306 is retrieved from the portable electrical energy storage device collection, charging and distribution machine 102 by the user who has been identified by the portable electrical energy storage device collection, charging and distribution machine 102.

25           Once the portable electrical energy storage device 106z is placed in the portable electrical energy storage device collection, charging and distribution machine 102 in the process of a user returning or exchanging the portable electrical energy storage device 106z at the portable electrical energy storage device collection, charging and distribution machine 102, and the information  
30 regarding the vehicle event data has been provided to the user or otherwise utilized, the portable electrical energy storage device collection, charging and distribution machine 102 may initiate a deletion of the vehicle event data from the event data storage system 306 or cause the stored vehicle identification data to be able to be overwritten (e.g., to make room for storage of vehicle event data

The at least one controller may be further configured to wirelessly receive the event data regarding the vehicle from the vehicle event detection system. The at least one memory device may be configured to be wirelessly coupled to the at least one controller. The at least one controller may be further configured to  
5 enable the at least some event data stored on the at least one memory device to be provided to an external device. The at least one controller may be at least one controller component of a mobile device. The at least one controller may receive the information regarding authentication via a wireless signal transmitted from the external device. The device is a portable electrical energy storage  
10 device collection, charging and distribution machine.

The vehicle event data processing system may further comprise a wireless communications module coupled to the at least one memory device. The wireless communications module may be configured to enable the at least  
15 some event data stored on the at least one memory device to be provided wirelessly to an external device. The event data may include at least some information regarding one or more of: an accident involving the vehicle, an emergency involving the vehicle, a breakdown of the vehicle, a catastrophic failure of the vehicle, a signal from a tilt sensor, a signal from a gravity sensor, a  
20 signal from an accelerometer, a signal from a shock sensor, temperature of the vehicle or vehicle components, temperature of a battery of the vehicle, temperature of a motor of the vehicle, temperature of an electronic component of the vehicle, data, signal or information from a temperature sensor, data, signal or information from a battery temperature sensor, dangerous temperature levels,  
25 temperature levels over or under one or more threshold temperatures, dangerous driving behavior, and one or more types of driving behaviors.

A vehicle event data processing system may be summarized as including: at least one controller; and at least one memory device configured to  
30 be coupled to the at least one controller, and wherein the at least one controller may: receive event data regarding the vehicle; store at least some of the event data in the memory device; and communicate at least some of the event data for display on a device.

of other vehicles in which the portable electrical energy storage device 106z will be used). In some embodiments, the currently stored vehicle event data may be deleted or caused to be able to be overwritten by the event data storage system 306 or vehicle event detection system 418 upon re-connection of the event data storage system 306 to the vehicle event detection system 418, or upon  
5 connection to a different vehicle than that which is associated with the currently stored vehicle event data on the event data storage system 306.

Figure 5 is a flow diagram showing a method 500 of operating the system for providing vehicle event data of Figures 3 and 4A, according to one non-limiting illustrated embodiment.  
10

At 502, the system for providing vehicle event data receives event data regarding the vehicle.  
15

At 504, the system for providing vehicle event data stores at least some of the event data in the memory device.

At 506, the system for providing vehicle event data communicates at least some of the event data for display on a device.  
20

Figure 6 is a flow diagram showing a method 600 of operating the vehicle event data information management system of Figure 3A, according to one non-limiting illustrated embodiment, including enabling data to be provided to an external device, useful in the method of Figure 5.  
25

At 602, the vehicle event data information management system electronically receives vehicle event data over a period of time longer than a day regarding one or more vehicles.  
30

At 604, the vehicle event data information management system electronically identifies a specific vehicle, a specific user and a specific portable electrical energy storage device associated with respective events of a plurality of events indicated by the received event data.

At 606, the vehicle event data information management system electronically receives a request for information regarding a requested one of the specific vehicle, the specific user and the specific portable electrical energy storage device.

At 608, the vehicle event data information management system, in response to the request, electronically provides the respective events of the plurality of events indicated by the received event data associated with the requested one of the specific vehicle, the specific user and the specific portable electrical energy storage device.

Figure 7 is a flow diagram showing a method 700 of communicating event data received from a sensor indicative of an impact to a portable electrical energy storage device in an electric vehicle, according to one non-limiting illustrated embodiment.

At 702, the system for providing vehicle event data receives event data from a sensor indicative of an impact to a portable electrical energy storage device in an electric vehicle.

At 704, the system for providing vehicle event data stores at least some of the event data in one or more of: a memory device of the portable electrical energy storage device and a memory device of the vehicle.

At 706, the system for providing vehicle event data communicates at least some of the event data for display on a device.

The foregoing detailed description has set forth various embodiments of the devices and/or processes via the use of block diagrams, schematics, and examples. Insofar as such block diagrams, schematics, and examples contain one or more functions and/or operations, it will be understood by those skilled in the art that each function and/or operation within such block diagrams, flowcharts, or examples can be implemented, individually and/or collectively, by

a wide range of hardware, software, firmware, or virtually any combination thereof. In one embodiment, the present subject matter may be implemented via one or more microcontrollers. However, those skilled in the art will recognize that the embodiments disclosed herein, in whole or in part, can be equivalently  
5 implemented in standard integrated circuits (e.g., Application Specific Integrated Circuits or ASICs), as one or more computer programs executed by one or more computers (e.g., as one or more programs running on one or more computer systems), as one or more programs executed by on one or more controllers (e.g., microcontrollers) as one or more programs executed by one or more  
10 processors (e.g., microprocessors), as firmware, or as virtually any combination thereof, and that designing the circuitry and/or writing the code for the software and/or firmware would be well within the skill of one of ordinary skill in the art in light of the teachings of this disclosure.

15           When logic is implemented as software and stored in memory, logic or information can be stored on any non-transitory computer-readable medium for use by or in connection with any processor-related system or method. In the context of this disclosure, a memory is a nontransitory computer- or processor-  
20 readable storage medium that is an electronic, magnetic, optical, or other physical device or means that non-transitorily contains or stores a computer and/or processor program. Logic and/or the information can be embodied in any computer-readable medium for use by or in connection with an instruction execution system, apparatus, or device, such as a computer-based system, processor-containing system, or other system that can fetch the instructions from  
25 the instruction execution system, apparatus, or device and execute the instructions associated with logic and/or information.

In the context of this specification, a "computer-readable medium" can be any physical element that can store the program associated with logic and/or  
30 information for use by or in connection with the instruction execution system, apparatus, and/or device. The computer-readable medium can be, for example, but is not limited to, an electronic, magnetic, optical, electromagnetic, infrared, or semiconductor system, apparatus or device. More specific examples (a non-exhaustive list) of the computer readable medium would include the following: a

portable computer diskette (magnetic, compact flash card, secure digital, or the like), a random access memory (RAM), a read-only memory (ROM), an erasable programmable read-only memory (EPROM, EEPROM, or Flash memory), a portable compact disc read-only memory (CDROM), and digital tape.

5

Aspects of the embodiments can be modified, if necessary, to employ systems, circuits and concepts of the various patents, applications and publications to provide yet further embodiments. While generally discussed in the environment and context of collection, charging and distribution of portable electrical energy storage devices for use with personal transportation vehicle such as all-electric scooters and/or motorbikes, the teachings herein can be applied in a wide variety of other environments, including other vehicular as well as non-vehicular environments.

15

The above description of illustrated embodiments, including what is described in the Abstract of the Disclosure, is not intended to be exhaustive or to limit the embodiments to the precise forms disclosed. Although specific embodiments and examples are described herein for illustrative purposes, various equivalent modifications can be made without departing from the spirit and scope of the disclosure, as will be recognized by those skilled in the relevant art.

20

These and other changes can be made to the embodiments in light of the above-detailed description. In general, in the following claims, the terms used should not be construed to limit the claims to the specific embodiments disclosed in the specification and the claims, but should be construed to include all possible embodiments along with the full scope of equivalents to which such claims are entitled. Accordingly, the claims are not limited by the disclosure.

25

The at least one memory device may be configured to be coupled to the at least one controller when a portable electrical energy storage device is operably placed in the vehicle. The at least one controller may be attached to the electrical energy storage device. The device may be a mobile device. The device  
5 may be a dashboard display of a vehicle. The at least one controller may be further configured to receive the event data regarding the vehicle from a vehicle event detection system of the vehicle. The at least one controller may be further configured to wirelessly receive the event data regarding the vehicle from the vehicle event detection system. The at least one memory device may be  
10 configured to be wirelessly coupled to the at least one controller. The at least one controller may be further configured to enable the at least some event data stored on the at least one memory device to be provided to an external device. The at least one controller may be at least one controller component of a mobile device. The at least one controller may be further configured to enable the at  
15 least some event data stored on the at least one memory device to be provided to an external device via a wired connection to the external device. The device may be a portable electrical energy storage device collection, charging and distribution machine.

20 The vehicle event data processing system may further include a wireless communications module coupled to the at least one memory device, and the wireless communications module may be configured to enable the at least some event data stored on the at least one memory device to be provided wirelessly to an external device.

25

The event data may include at least some information regarding one or more of: an accident involving the vehicle, an emergency involving the vehicle, a breakdown of the vehicle, a catastrophic failure of the vehicle, a signal from a tilt sensor, a signal from a gravity sensor, a signal from an accelerometer, a signal  
30 from a shock sensor, dangerous driving behavior, temperature of the vehicle or vehicle components, temperature of a battery of the vehicle, temperature of a motor of the vehicle, temperature of an electronic component of the vehicle, data, signal or information from a temperature sensor, data, signal or information from a battery temperature sensor, dangerous temperature levels, temperature

levels over or under one or more threshold temperatures, and one or more types of driving behaviors. The at least one controller may communicate at least some of the event data for display on a device by communicating at least some of the event data to a display of a device including the controller.

5

A method in a vehicle event data processing system may be summarized as including: electronically receiving, by a processor of vehicle event data system, vehicle event data over a period of time longer than a day regarding one or more vehicles; electronically identifying, by a processor of the vehicle event data system, a specific vehicle, a specific user and a specific portable electrical energy storage device associated with respective events of a plurality of events indicated by the received event data; electronically receiving a request for information regarding a requested one of the specific vehicle, the specific user and the specific portable electrical energy storage device; and in response to the request, electronically provide, by a processor of vehicle event data system, the respective events of the plurality of events indicated by the received event data associated with the requested one of the specific vehicle, the specific user and the specific portable electrical energy storage device.

20

The method in a vehicle event data processing system may further include: electronically detecting, by a processor of the vehicle event data system, a pattern of safety problems regarding one or more of: a specific vehicle, a specific user and a specific portable electrical energy storage device associated with the respective events of the plurality of events based on the identification of the specific vehicle, the specific user and the specific portable electrical energy storage device associated with the respective events of the plurality of events indicated by the received event data.

25

30

The method in a vehicle event data processing system may further include: electronically communicating, by a processor of the vehicle event data system, information regarding the detected pattern of safety problems regarding the one or more of the specific vehicle, the specific user and the specific portable electrical energy storage device associated with the respective events of the plurality of events to a remote device.

The method in a vehicle event data processing system may further include: receiving a request for collection of a certain type of data by the vehicle with selectable parameters to aid in in-field diagnostics of the vehicle; and in  
5 response to the request, providing the certain type of data according to the selectable parameters.

The remote device may be a mobile device of the specific user. The detected pattern of safety problems may be regarding the specific portable  
10 electrical energy storage device and the method may further include electronically determining, by a processor of the vehicle event data system, a change to make regarding distribution of the specific portable electrical energy storage device to collection, charging and distribution machines based on the detected pattern of safety problems regarding the portable electrical energy  
15 storage device.

A non-transitory computer readable storage medium may be summarized as having computer executable instructions thereon that, when executed, cause a processor of a vehicle event data system to: receive event data from a sensor  
20 indicative of an impact to a portable electrical energy storage device in an electric vehicle; store at least some of the event data in one or more of: a memory device of the portable electrical energy storage device and a memory device of the vehicle; and communicate at least some of the event data for display on a device.  
25

The non-transitory computer readable storage medium may have computer executable instructions thereon that, when executed, further cause a processor of the vehicle event data system to: electronically receive vehicle event data over a period of time longer than a day regarding the electric vehicle;  
30 electronically identify a specific user and a specific portable electrical energy storage device associated with respective events of a plurality of events indicated by the vehicle event data regarding the electric vehicle received over the period of time; and provide information regarding the identification of the specific user and the specific portable electrical energy storage device

associated with the respective events of the plurality of events to a remote device.

#### BRIEF DESCRIPTION OF THE SEVERAL VIEWS OF THE DRAWINGS

5           In the drawings, identical reference numbers identify similar elements or acts. The sizes and relative positions of elements in the drawings are not necessarily drawn to scale. For example, the shapes of various elements and angles are not drawn to scale, and some of these elements are arbitrarily enlarged and positioned to improve drawing legibility. Further, the particular  
10 shapes of the elements as drawn, are not intended to convey any information regarding the actual shape of the particular elements, and have been solely selected for ease of recognition in the drawings.

          Figure 1 is a schematic view of a collection, charging and distribution  
15 machine along with a number of portable electrical energy storage devices, an electric scooter or motorbike, and an electrical service provided via an electrical grid according to one non-limiting illustrated embodiment.

          Figure 2 is a block diagram of the collection, charging and distribution  
20 machine of Figure 1, according to one non-limiting illustrated embodiment.

          Figure 3A is a block diagram of a system for providing vehicle event data which shows collection, charging and distribution machines, such as that of  
25 Figure 1, within the system, according to one non-limiting illustrated embodiment.

          Figure 3B is a block diagram of the portable electrical energy storage device of Figure 1, according to one non-limiting illustrated embodiment.

30           Figure 4A is a schematic view of the vehicle event data storage system of Figure 3B coupled to a vehicle event detection system, according to one non-limiting illustrated embodiment.

Figure 4B is an illustration of example information displayed on a user interface screen regarding vehicle event data received from the vehicle event data information management system of Figure 3A and/or the vehicle event data storage system of Figure 3B and Figure 4A, according to one non-limiting illustrated embodiment.

Figure 5 is a flow diagram showing a method of operating the system for providing vehicle event data of Figures 3 and 4A, according to one non-limiting illustrated embodiment.

Figure 6 is a flow diagram showing a method of operating the vehicle event data information management system of Figure 3A, according to one non-limiting illustrated embodiment, including enabling data to be provided to an external device, useful in the method of Figure 5.

Figure 7 is a flow diagram showing a method of communicating event data from a sensor indicative an impact to a portable electrical energy storage device in an electric vehicle, according to one non-limiting illustrated embodiment.

#### DETAILED DESCRIPTION

In the following description, certain specific details are set forth in order to provide a thorough understanding of various disclosed embodiments. However, one skilled in the relevant art will recognize that embodiments may be practiced without one or more of these specific details, or with other methods, components, materials, etc. In other instances, well-known structures associated with vending apparatus, batteries, supercapacitors or ultracapacitors, power converters including but not limited to transformers, rectifiers, DC/DC power converters, switch mode power converters, controllers, and communications systems and structures and networks have not been shown or described in detail to avoid unnecessarily obscuring descriptions of the embodiments.

Unless the context requires otherwise, throughout the specification and claims which follow, the word "comprise" and variations thereof, such as,

## CLAIMS

1. A method in a vehicle event data processing system comprising the method comprising:

5 electronically receiving, by a processor of vehicle event data system, vehicle event data over a period of time longer than a day regarding one or more vehicles;

electronically identifying, by a processor of the vehicle event data system, a specific vehicle, a specific user and a specific portable electrical energy storage device associated with respective events of a plurality of events indicated by the received event data;

electronically receiving a request for information regarding a requested one of the specific vehicle, the specific user and the specific portable electrical energy storage device; and

15 in response to the request, electronically displaying on a display device, by a processor of vehicle event data system, the respective events of the plurality of events indicated by the received event data associated with the requested one of the specific vehicle, the specific user and the specific portable electrical energy storage device.

20

2. The method of claim 1 further comprising:

electronically detecting, by a processor of the vehicle event data system, a pattern of safety problems regarding one or more of: a specific vehicle, a specific user and a specific portable electrical energy storage device associated with the respective events of the plurality of events based on the identification of the specific vehicle, the specific user and the specific portable electrical energy storage device associated with the respective events of the plurality of events indicated by the received event data.

25  
30

3. The method of claim 2 further comprising: electronically communicating, by a processor of the vehicle event data system, information regarding the detected pattern of safety problems regarding the one or more of

2018 JUL -3 PM 4:06  
OFFICE OF THE  
REGISTERED PROFESSIONAL ENGINEER

the specific vehicle, the specific user and the specific portable electrical energy storage device associated with the respective events of the plurality of events to a remote device.

5           4. The method of claim 2 wherein the detected pattern of safety problems is regarding the specific portable electrical energy storage device and wherein the method further comprises electronically determining, by a processor of the vehicle event data system, a change to make regarding distribution of the specific portable electrical energy storage device to collection, charging and  
10 distribution machines based on the detected pattern of safety problems regarding the portable electrical energy storage device.

          5. The method of claim 1 further comprising:  
          receiving a request for collection of a certain type of data by the vehicle  
15 with selectable parameters to aid in in-field diagnostics of the vehicle; and  
          in response to the request, providing the certain type of data according to the selectable parameters.

          6. The method of claim 1 wherein the remote device is a mobile device  
20 of the specific user.

          7. A non-transitory computer readable storage medium having computer executable instructions thereon that, when executed, cause a processor of a vehicle event data system to:  
25           receive event data from a sensor indicative of an impact to a portable electrical energy storage device in an electric vehicle;  
          store at least some of the event data in one or more of a memory device of the portable electrical energy storage device and a memory device of the vehicle;  
30           communicate at least some of the event data for display on a device;  
          electronically receive vehicle event data over a period of time longer than a day regarding the electric vehicle;

electronically identify a specific user and a specific portable electrical energy storage device associated with respective events of a plurality of events indicated by the vehicle event data regarding the electric vehicle received over the period of time; and

- 5 display on a display device information regarding the identification of the specific user and the specific portable electrical energy storage device associated with the respective events of the plurality of events to a remote device.



By: *[Signature]*  
 Attorneys  
 GOGORO INC.  
 Applicant  
 SAPALO VELEZ BUNDANG & BULLIAN

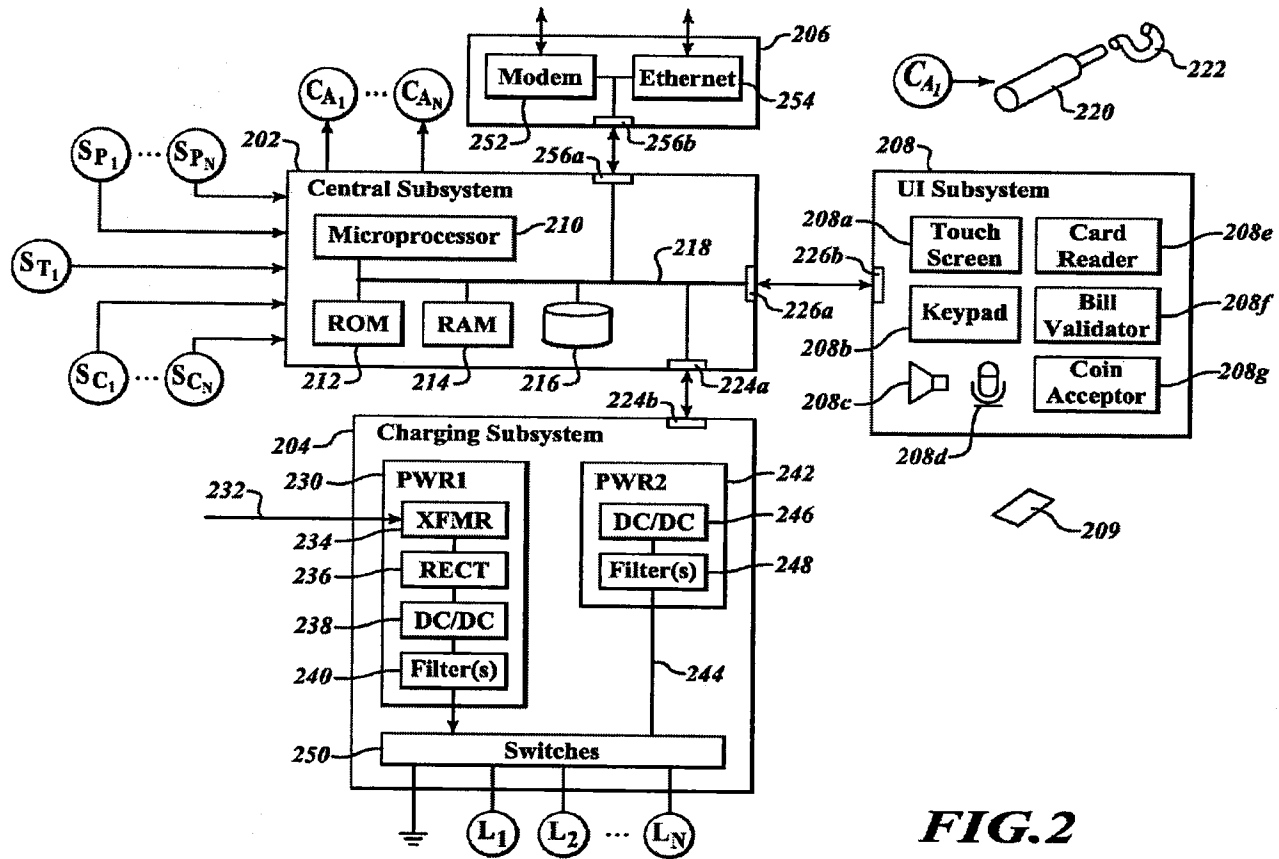
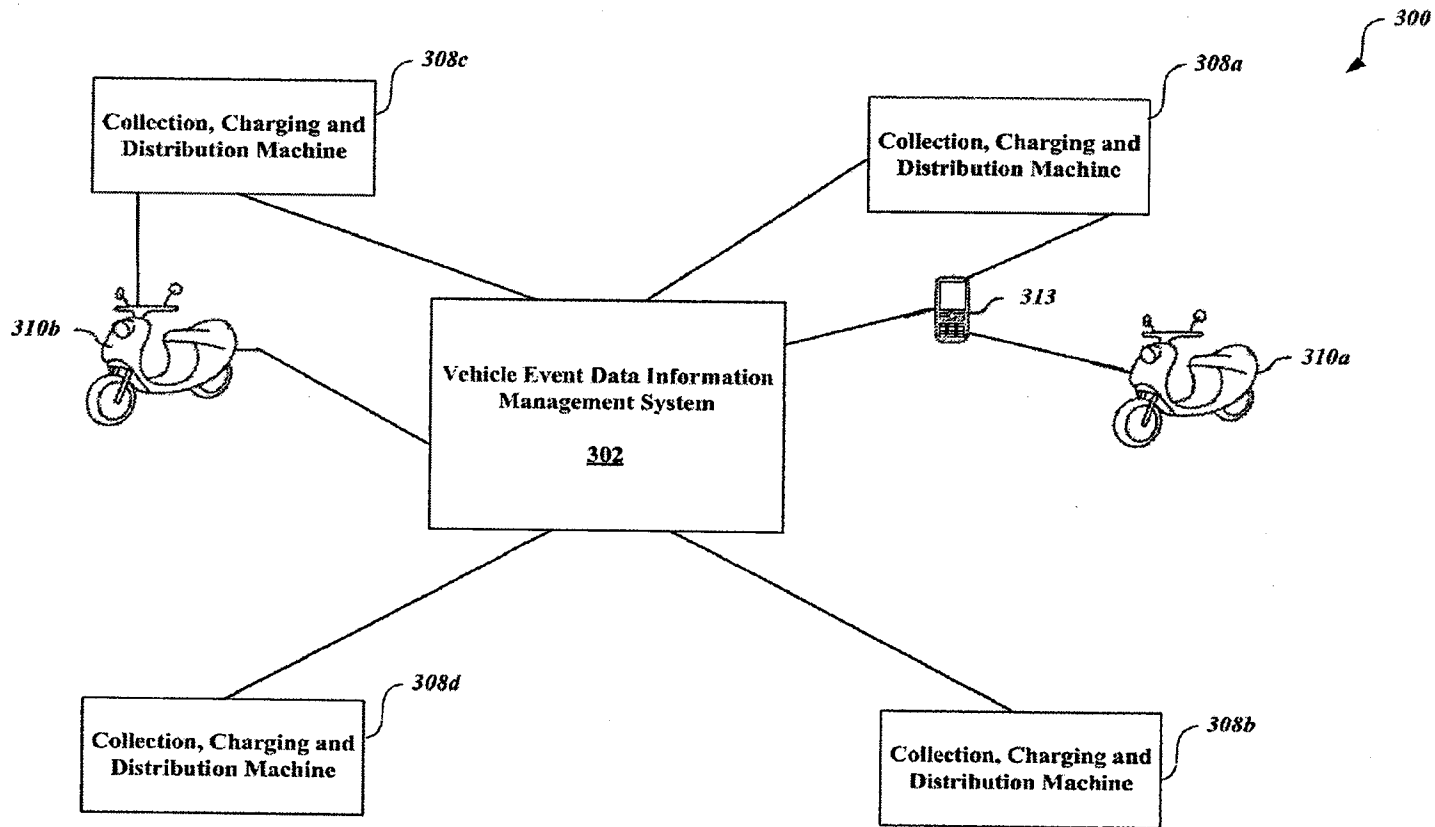
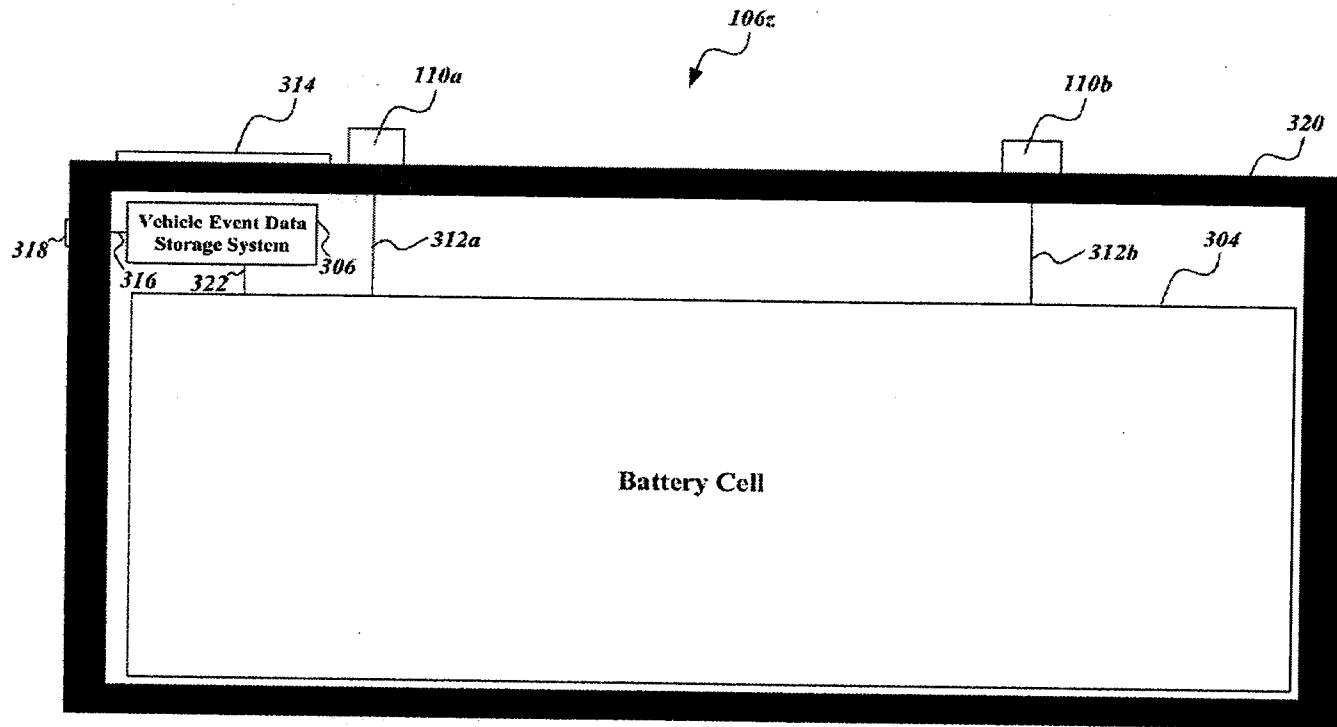


FIG. 2



**FIG. 3A**

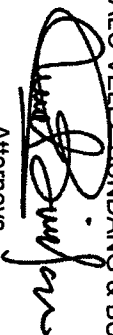
GOGORO INC.  
 Applicant  
 SAPALO VELEZ BUNDANG & BULLIAN  
 Attorneys  
 By: *[Signature]*



**FIG. 3B**

GOGORO INC.  
 Applicant  
 SAPALO VELEZ BUNDEANG & BULLIAN  
 Attorneys

By:

BY:   
SAPALO VELEZ RUNDANG & BULLIAN  
Applicant  
GOGORO INC.  
Attorneys

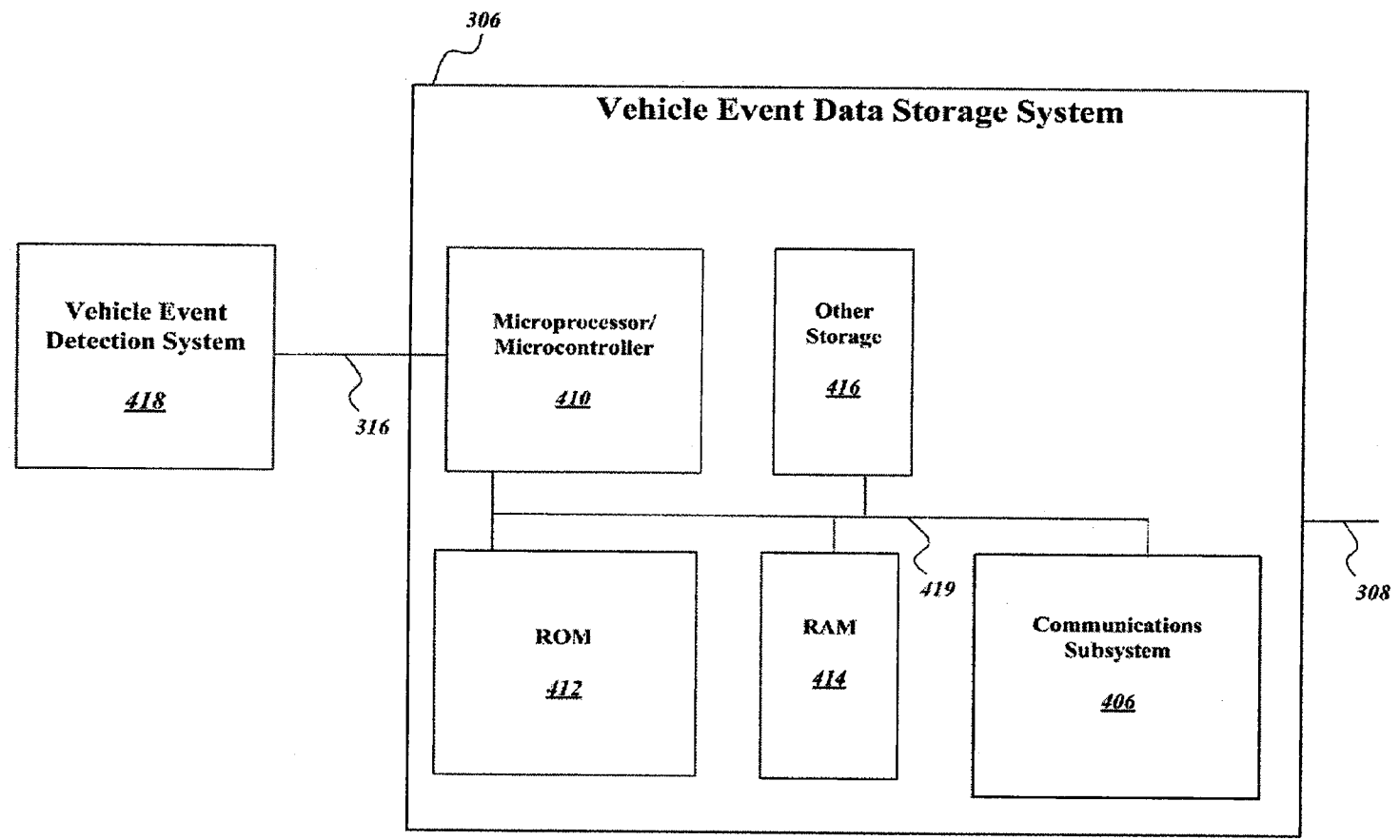


FIG. 4A

By:  
GOGORO INC.  
Applicant  
SAPALO VELEZ BUNDANG & BULLIAN  
Attorneys

420

422

### Vehicle Event Report

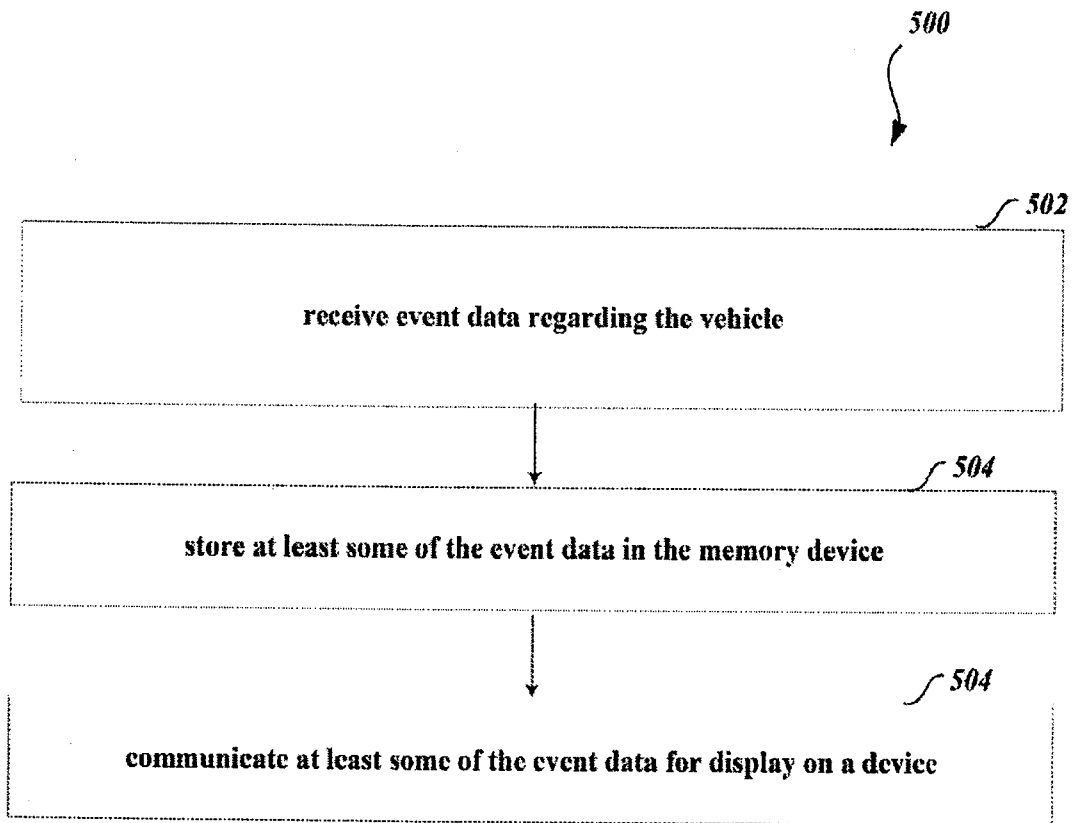
424 A vehicle impact was detected based on the accelerometer in your vehicle.

426 Are you OK? Select: Yes No

Is your vehicle operating properly? Select: Yes No

428 Acknowledged

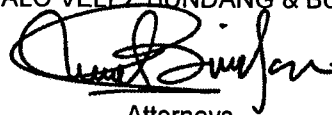
**FIG. 4B**

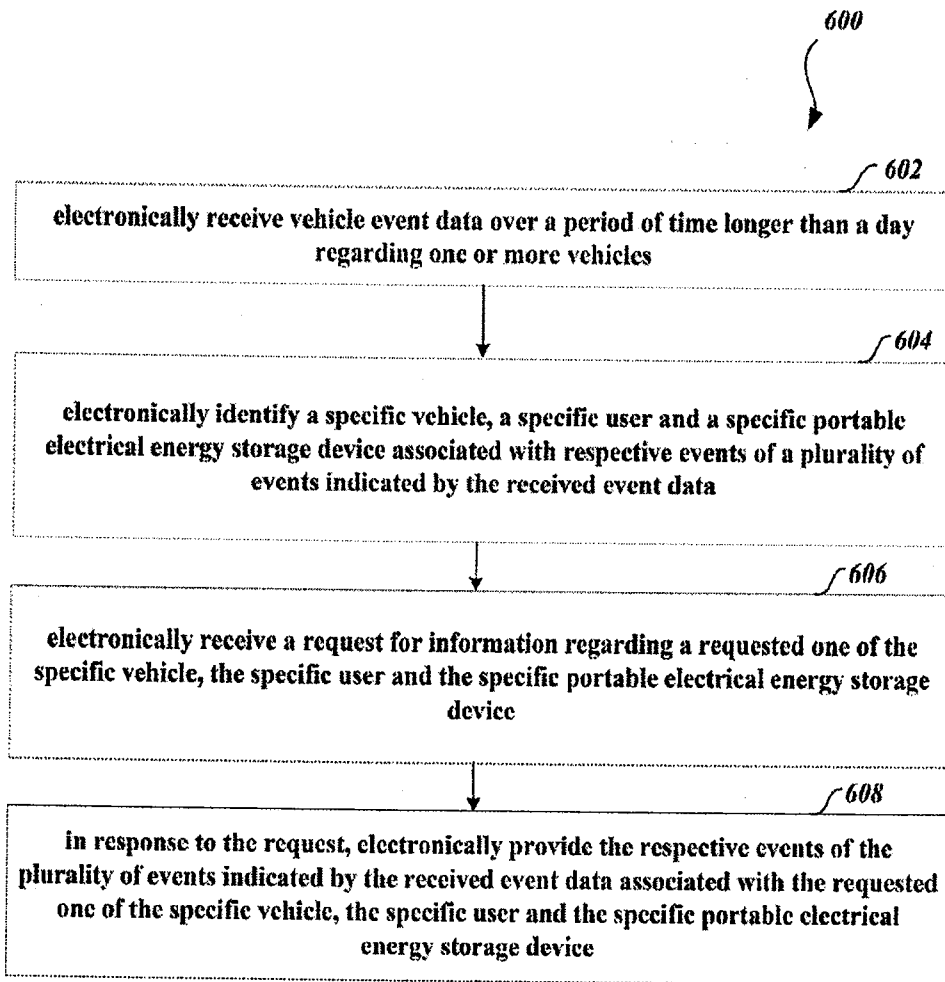


**FIG. 5**

GOGORO INC.  
Applicant  
SAPALO VELEZ BUNDANG & BULILAN

By:

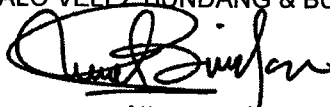
  
Attorneys

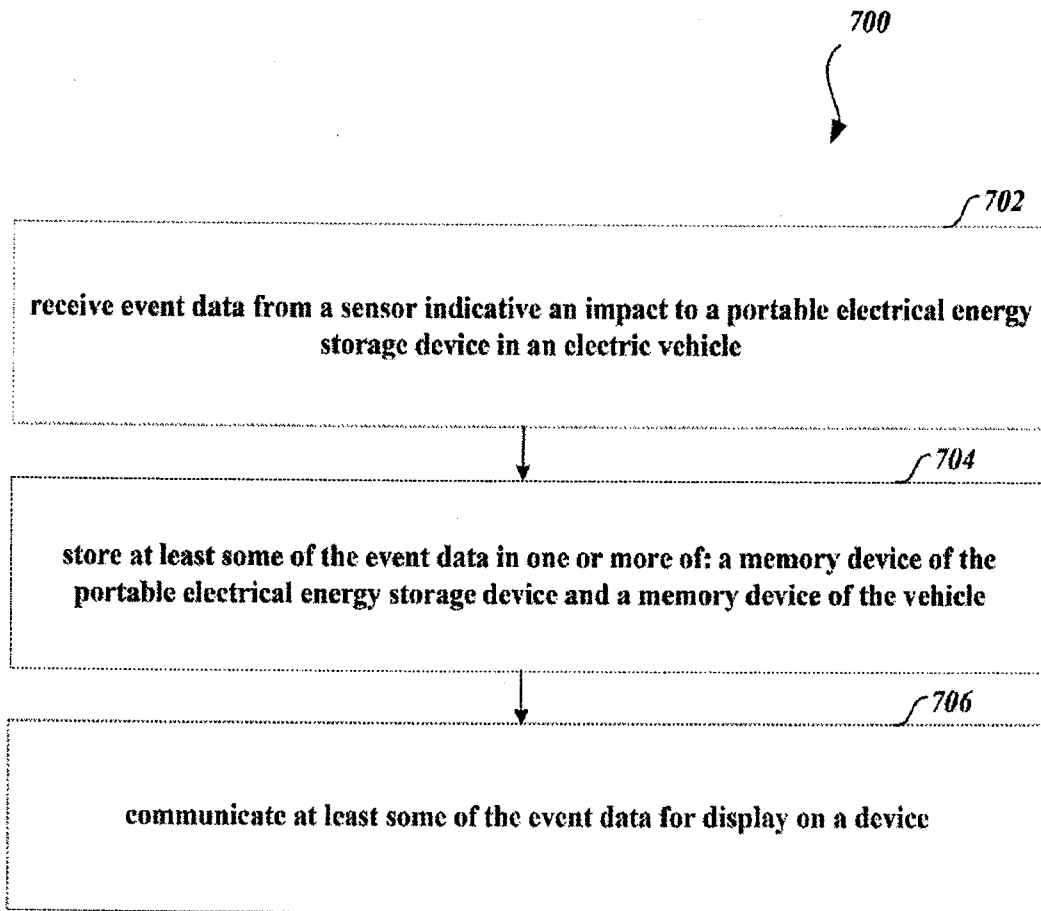


**FIG. 6**

GOGORO INC.  
Applicant  
SAPALO VELEZ BUNDANG & BULILAN

By:

  
Attorneys



**FIG. 7**

2018 JUL - 9 PM 4:16  
 PROVISIONAL  
 PATENT OFFICE

GOGORO INC.  
 Applicant  
 SAPALO VELEZ BUNDANG & BULILAN

By:

*[Handwritten Signature]*  
 Attorneys