

(No Model.)

2 Sheets—Sheet 1.

Z. E. MOON.  
BOILER FURNACE.

No. 523,901.

Patented July 31, 1894.

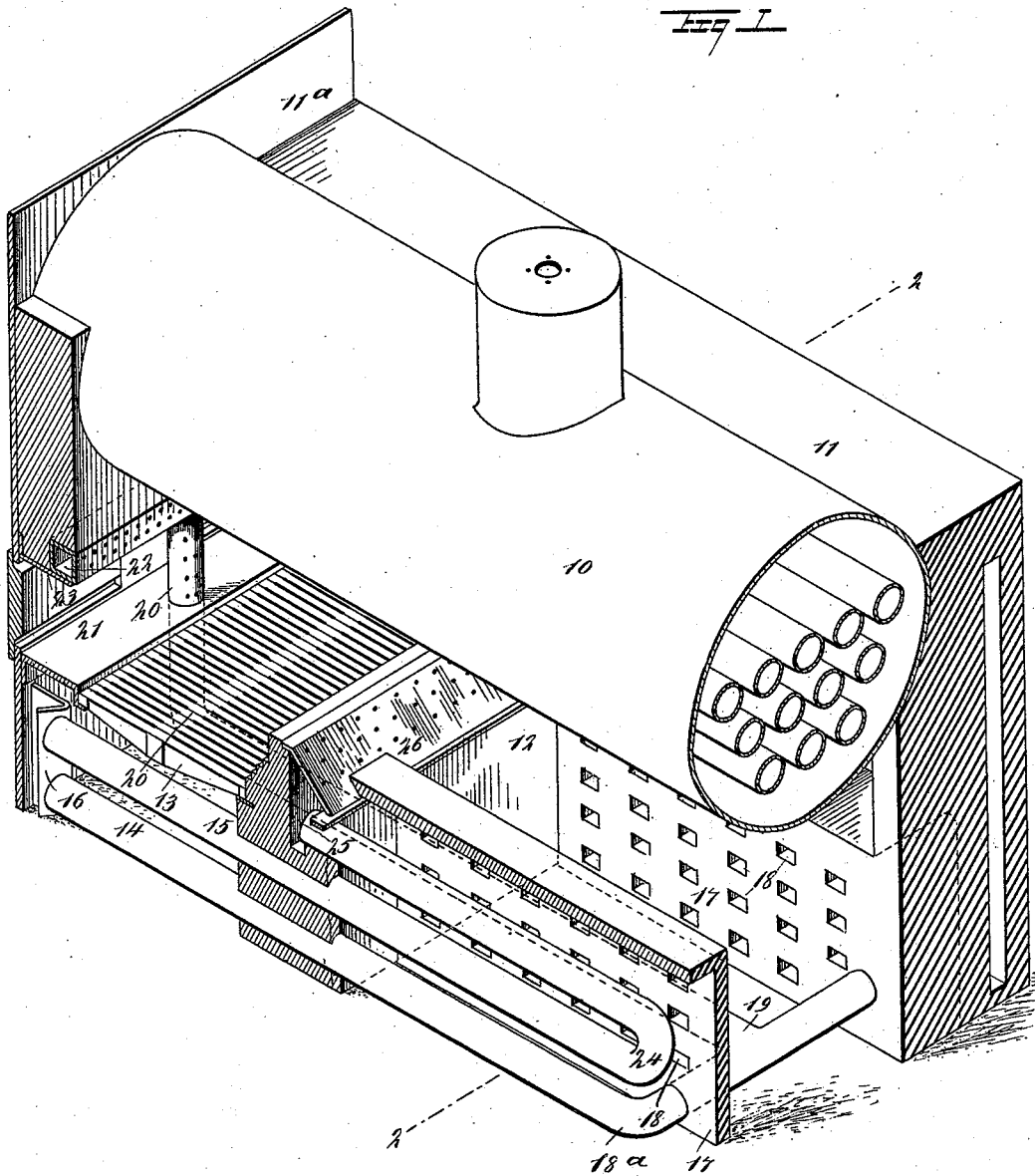

WITNESSES:  
*H. Walker*  
*C. Sedgwick*

INVENTOR  
*Z. E. Moon*  
BY  
*Munn & Co.*  
ATTORNEYS.

(No Model.)

2 Sheets—Sheet 2.

Z. E. MOON.  
BOILER FURNACE.

No. 523,901.

Patented July 31, 1894.

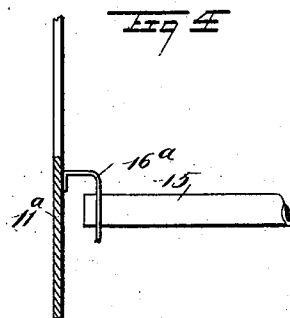
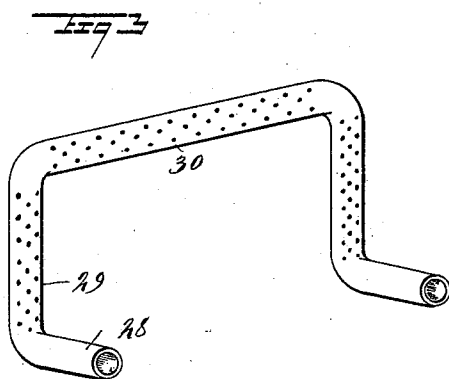
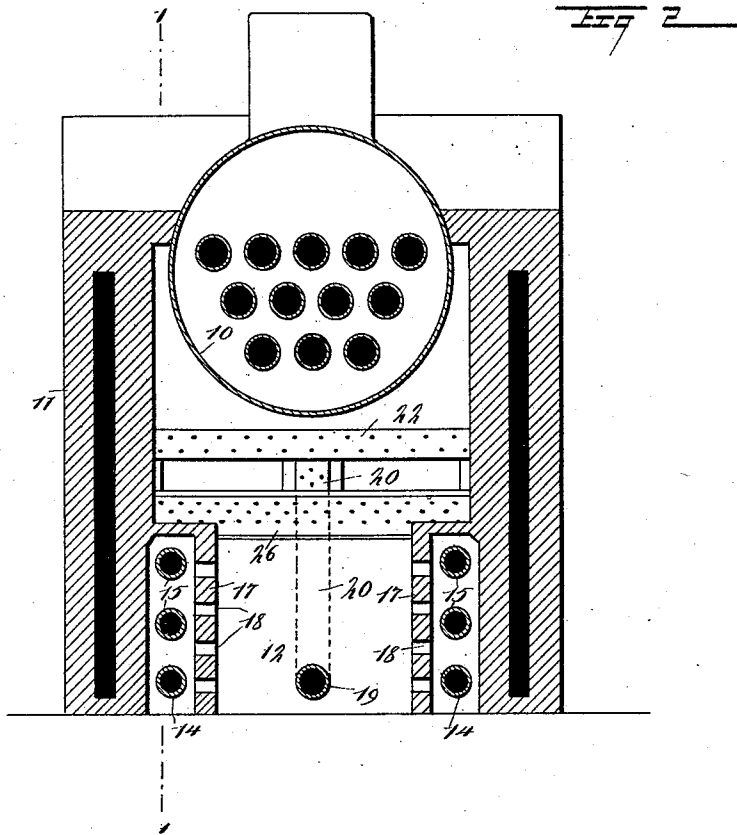

WITNESSES:  
*H. Walker*  
*A. Lurcott*

INVENTOR  
*Z. E. Moon*  
BY *Munnif*  
ATTORNEYS.

# UNITED STATES PATENT OFFICE.

ZENAS EDWIN MOON, OF SCHUYLER, NEBRASKA, ASSIGNOR TO HIMSELF,  
AND JAMES S. STANDEFORD, OF COUNCIL BLUFFS, IOWA.

## BOILER-FURNACE.

SPECIFICATION forming part of Letters Patent No. 523,901, dated July 31, 1894.

Application filed October 10, 1893. Serial No. 487,712. (No model.)

*To all whom it may concern:*

Be it known that I, ZENAS EDWIN MOON; of Schuyler, in the county of Colfax and State of Nebraska, have invented a new and Improved Boiler-Furnace, of which the following is a full, clear, and exact description:

My invention relates to improvements in boiler furnaces; and the object of my invention is to produce a furnace and certain attachments thereof which are applicable to any ordinary horizontal boilers, and especially to horizontal flue and tubular boilers, also to construct the furnace and its attachments in such a way that atmospheric air may be taken from the ash pit and delivered in a heated condition into the fire box and also into the furnace behind the bridge wall, to the end that the air may mingle with the gases of the fire and thus promote combustion and also that the heat may be evenly distributed upon the heating surface of the boiler so that steam is quickly generated and the life of the boiler prolonged.

To these ends my invention consists of certain features of construction and combinations of parts, as will be hereinafter described and claimed.

Reference is to be had to the accompanying drawings, forming a part of this specification, in which similar figures of reference indicate corresponding parts in all the views.

Figure 1 is an inside perspective view of the apparatus embodying my invention, the furnace wall and a portion of the boiler being shown in section, on the line 1—1 in Fig. 2. Fig. 2 is a cross section on the line 2—2 of Fig. 1. Fig. 3 is a perspective view of a perforated pipe which may be used instead of the perforated air plate, this arrangement being a modified form of the invention; and Fig. 4 is a broken detail sectional plan, showing the arrangement of one of the air pipes in the ash pit.

The boiler 10 is the usual horizontal boiler, and is mounted in the customary manner in masonry 11, and has the customary front plate 11<sup>a</sup>. Beneath the boiler is the usual bridge wall 12, which forms the back of the fire box and the fire box has the customary grate 13. Leading from the ash pit and preferably near opposite sides thereof are air

pipes 14 and 15, the ends of which are held in the shield 16, as illustrated in Fig. 1, the shield being of nearly triangular cross section, and its object is to permit the air to enter the pipes, but it excludes ashes and other refuse.

The shield may be of different shape, as shown at 16<sup>a</sup> in Fig. 4, and the apparatus may be used without the shield, although it is preferably employed.

Behind the bridge wall and on opposite sides of the combustion chamber are brick arches 17, and these arches are provided with numerous perforations 18 to facilitate the circulation of heat and insure a consequent even temperature. The arches are preferably of fire brick, and they serve to protect the air pipes behind them and also permit the pipes to be sufficiently heated to heat the air within them. The bricks also hold the heat sufficiently to keep the pipes behind them hot when the fire is low or fresh fuel is applied to the fire.

The lower pipes 14 extend through the bridge wall, as best shown in Fig. 1, and at the rear end of the furnace they are bent inward at 18<sup>a</sup> so as to extend inward through the arches 17 and they merge in a pipe 19, which extends forward through the bridge wall to the front portion of the ash pit and here it is bent upward, as shown at 20, and its inner side that is, the side facing the bridge wall, is provided with numerous perforations, as shown clearly in Fig. 1, so that hot air may issue into the fire box and mingle with the gases therein so as to promote combustion.

The bent end 20 of the central air pipe extends upward in front of the grate, through the supporting plate 21 and delivers into the flue 22 on the arch plate 23 which is arranged in the usual way above the furnace doors. The flue 22 is perforated on its inner side, as shown in Fig. 1, and the hot air issues from the flue into the fire box for the purpose above specified.

The upper pipes 15 extend rearwardly through the bridge wall, parallel with the pipes 14, and are then doubled and returned upon themselves, as shown at 24 in Fig. 1, and they deliver into a flue 25 which is made transversely in the upper portion and back side of

the bridge wall, and this flue is covered by a perforated plate 26, which is placed at an angle to the top of the wall and at an angle to the boiler, so that the hot air which rises from the flue passes rearwardly and upwardly so as to mingle with the products of combustion which pass from the fire box, and the gases are thus consumed and the heat is evenly distributed upon the boiler, as the jets of air from the flue 25 do not impinge upon the boiler, but flow backward at the right angle to mingle with the gases from the fire box.

Instead of having the pipe 19 deliver into the flue 22, as shown in Fig. 1, pipes 28 may be arranged on opposite sides of the fire box to connect with return pipes forming part of the pipes 14, and the pipes 28 may be bent upward, as shown at 29, and then laterally, as shown at 30, so as to form an arch adapted to lie in the front end of the fire box, and the arch thus formed is perforated, as shown in Fig. 3, so as to deliver the hot air into the fire box. Or the flue 22 may be used and the ends 29 of the pipes 28 connected with the ends of this flue.

To keep the holes in the flues clear, steam pipes may be made to deliver into the air pipes behind the shields 16.

It will be seen from the above description that when the fire is built in the fire box, the pipes 14, 15 and 19 will be heated and will thus create a draft so that air will be sucked in from behind the shield 16 and delivered in numerous series of jets from the flues 22 and 25, so that the air is thoroughly mingled with the gases of the furnace, and an intense heat is produced which is evenly applied to the boiler, causes the smoke to be in a great measure consumed, and effects a great saving of fuel.

Having thus described my invention, I claim as new and desire to secure by Letters Patent—

1. The combination with a boiler furnace, of an air pipe opening into and leading from the forward part of the ash pit to the rear of the furnace and then back again to the said forward part of the ash pit, and a perforated flue in the front portion of the fire box and with which the air pipe is connected, substantially as described.

2. The combination with a boiler furnace, of air pipes extending from the ash pit through the bridge wall to the rear of the furnace, a central pipe connected with the said air pipes

and extending forward through the said bridge wall to the ash pit and having its end bent upward and perforated, and a perforated flue arranged in the front of the fire box and with which the said bent end is connected, substantially as described.

3. The combination with a boiler furnace, of a perforated flue at the upper portion of the rear side of the bridge wall, and air pipes opening into the ash pit and leading therefrom to the rear of the furnace and thence forward and connected with the said flue, substantially as described.

4. The combination with a boiler furnace, of air pipes extending from the ash pit to the rear of the furnace and thence back to the forward part of the furnace and delivering into the fire box, and shields in the ash pit for the open ends of the air pipes, substantially as and for the purpose set forth.

5. The combination with a boiler furnace provided with perforated arches in rear of the bridge wall and on opposite sides of the combustion chamber, of air pipes extending from the ash pit through the bridge wall into the said arches and thence inward through the arches, a central pipe connected with the said air pipes and extending forward to the ash pit and having its end bent upward into the fire box, and a perforated flue in the front of the fire box and with which the said bent end is connected, substantially as described.

6. The combination with a boiler furnace provided with perforated arches in rear of the bridge wall and on opposite sides of the combustion chamber, of air pipes extending from the ash pit through the bridge wall into the said arches and thence inward through said arches, a pipe in the combustion chamber connected with the air pipes and extending forward to the ash pit and having its end projecting up into the fire box, a perforated flue in the fire box and to which said forwardly extending pipe is connected, a perforated flue on the rear of the bridge wall, and a second set of air pipes extending from the ash pit through the bridge wall into the arches and doubled upon themselves and extending forward to the flue on the rear of the bridge wall, substantially as herein shown and described.

ZENAS EDWIN MOON.

Witnesses:

VICTOR H. LOVEJOY,  
FRANK H. KOLM.