

(No Model.)

W. DENTON.

MACHINE FOR TRIMMING HEMS AND SEAMS OF SEWED ARTICLES.

No. 246,733.

Patented Sept. 6, 1881.

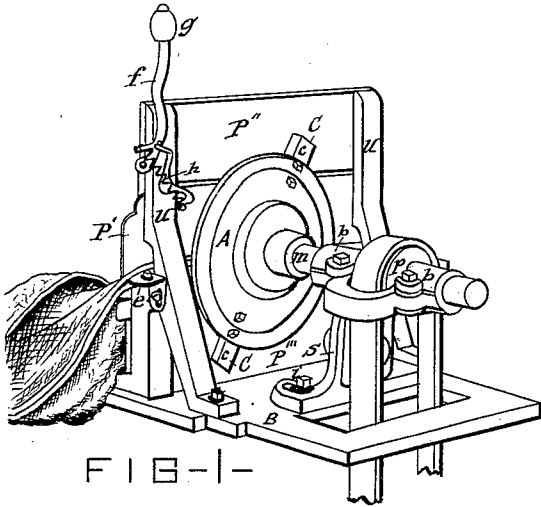

FIG-1-

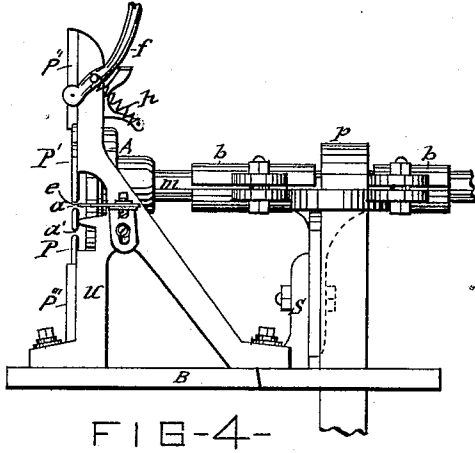

FIG-4-

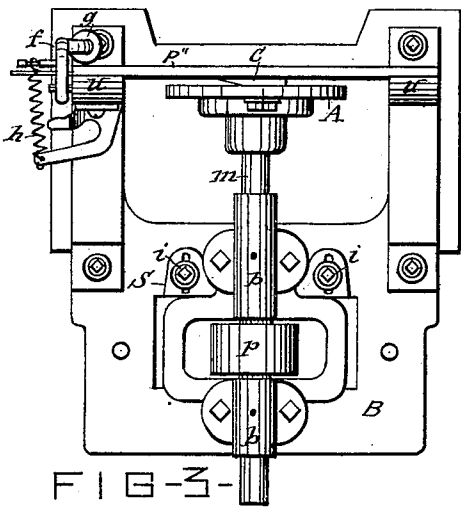

FIG-3-

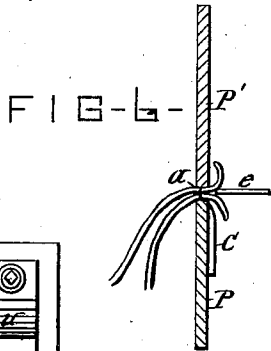

FIG-6-

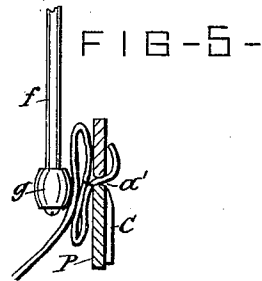

FIG-5-

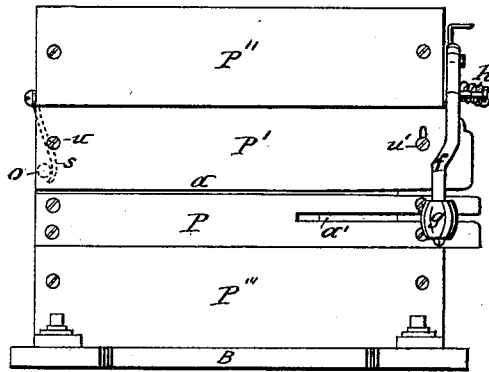

FIG-2-

WITNESSES=

Wm L. Raymond
C. Bendison

INVENTOR=

W. Denton
per H. L. Laess & Key
his Attorneys

UNITED STATES PATENT OFFICE.

WHITLEY DENTON, OF LITTLE FALLS, NEW YORK.

MACHINE FOR TRIMMING HEMS AND SEAMS OF SEWED ARTICLES.

SPECIFICATION forming part of Letters Patent No. 246,733, dated September 6, 1881.

Application filed July 11, 1881. (No model.)

To all whom it may concern:

Be it known that I, WHITLEY DENTON, of Little Falls, in the county of Herkimer, in the State of New York, have invented new and useful Improvements in Machines for Trimming Hems and Seams of Sewed Articles, of which the following, taken in connection with the accompanying drawings, is a full, clear, and exact description.

The nature of this invention relates to a novel, simple, and effective machine designed to expeditiously and accurately trim from the hem and seam of sewed articles the loose and rough edges of the fabric, which are especially common to the hems and seams of knitted underwear.

The invention consists, essentially, of a slotted guide adapted to receive through its slot the edge of the article to be trimmed, and a cutter or cutters arranged in proximity to said slot, for the purpose of cutting the protruding portion of the aforesaid article.

It also consists in certain peculiarities in the details of the aforesaid machine and certain auxiliary devices connected therewith, all as hereinafter more fully described, and specifically set forth in the claims.

In the annexed drawings, Figure 1 is a perspective view of my invention. Fig. 2 is a front view of the same. Fig. 3 is a plan view illustrating the adjustability of the cutters in their proximity to the guide through which the article to be trimmed is passed to the cutters. Fig. 4 is a side view of the machine, and Figs. 5 and 6 are enlarged detail views illustrating the operation of trimming a hem and a seam, respectively.

Similar letters of reference indicate corresponding parts in all the figures.

Upon a suitable base or bed plate, B, is secured a standard, S, which is provided with a journal box or boxes, b, in which is journaled a mandrel, m.

To one end of the mandrel is affixed a collar or face-plate, A, to which are attached knives or cutters C C, projecting from the periphery of said collar, as shown at c. The opposite end of the mandrel is provided with a pulley, p, which, by a belt connected with motive power, imparts rotary motion to the arbor.

Across the outer or front face of the cutter-

carrying collar A are arranged two plates, P P', which are connected to uprights U U, secured to the bed B, said plates being placed side by side, or one above the other, with a narrow slot, a, between their adjacent edges. The slot a constitutes the guide for feeding to the cutters the loose edges of a seam to be trimmed. The knives or cutters C C, passing over the slot a close to the rear of the guide-plates P P', cut away the protruding loose edges of the seam. The seam is passed endwise into the slot a, and is guided by the edges of the plates P P' pressing on the compressed stitched portion, and by means of a plate, e, which is attached to the upright U at the feed end of the guide-plates, and has its edge passing between the protruding loose edges of the seam. The mandrel, being made to revolve about eight hundred revolutions per minute, causes the projecting ends c of the cutters C to cut away the aforesaid loose edges as fast as they can conveniently be carried to them.

Since the seams vary in thickness, it becomes necessary to make the guide-slot a variable in width; and to accomplish this automatically I arrange the plate P' movable vertically and hold it yieldingly in its proximity to the plate P by means of a spring bearing on the plate P'. One mode of effecting this result is illustrated in the annexed drawings by making one of the attaching-screws, u, of the plate P' serve as a pivot for said plate, and vertically elongating the aperture for the attaching-screw u' at the opposite end of the plate, so as to allow the latter to vibrate vertically. The requisite downward pressure on the plate P' is obtained by a spring-plate, s, attached to the upright U at the pivoted end of the said plate, and bearing with its free end on a stud, o, on the plate P', as shown by dotted lines in Fig. 2 of the drawings. The loose edges of hems being nearly of a uniform thickness, the trimming of same does not require the before-described adjustability. I therefore provide the stationary guide-plate P with a slot, a', of the requisite width, the loose edge of the hem being introduced in said slot and passed endwise toward the cutters C in the same manner as the edges of a seam. In passing the hem as aforesaid it is held to its place in the guide a' by an arm, f, which is hinged to

the upper portion of the upright U, and carries on its free end a roller, *g*, which is made to press on the fabric back of the hem by the action of a spring, *h*, connected, respectively, with the upright U and arm *f*, as shown in Figs. 2 and 4 of the drawings. In trimming seams the arm *f* is swung out of the way, as illustrated in Fig. 1 of the drawings.

The machine is rendered adjustable to trim hems and seams at a greater or less distance from the stitches by providing the standard S, which carries the mandrel *m*, with elongated bolt-holes for the bolts *i*, by which it is secured to the bed B, thereby allowing the said standard to be set so as to bring the cutter-carrying collar A in any desired proximity to the guide-plates P P'.

In order to protect the operator against encounter with the cutters C C, plates P'' and P''' are secured to the uprights U above and below the guide-plates P P', respectively, so as to form a perfect shield in front of the cutters.

Having described my invention, what I claim as new, and desire to secure by Letters Patent, is—

1. A machine for trimming hems and seams of sewed articles, consisting, essentially, of a slotted guide adapted to receive through its slot the edge of the article to be trimmed, and a cutter or cutters arranged in proximity to said slot and movable over the same, for the purpose of cutting the protruding portion of the aforesaid article, substantially as set forth.

2. In combination with the cutters C, the plates P P', arranged side by side in front of said cutters and held yieldingly in relation to the distance between the adjacent edges of the plates, substantially as described, for the purpose specified.

3. In combination with the cutters C, the

stationary guide-plate P, the plate P', pivoted at one end, and having at the opposite end an elongated eye for the attaching-screw *u*', and the spring *s*, attached to the upright U, and bearing on a stud, *o*, on the plate P', substantially as described and shown.

4. In combination with the cutters C, the plates P P', having the slot *a* between them, and the plate *e*, having its edge in range with the slot *a*, substantially as described, for the purpose set forth.

5. In combination with the cutters C, the stationary plate P, provided with the slot *a'*, and the plate P', arranged by the side of the plate P movably to and from the same, and with a slot, *a*, between them, substantially as and for the purpose shown and set forth.

6. In combination with the cutters C, the plate P, provided with the slot *a'*, and an arm, *f*, bearing with its free end on said plate over the slot thereof, substantially as and for the purpose set forth.

7. In combination with the guide-plates P P' and the mandrel *m*, carrying the cutters C, the standard S, arranged adjustably in relation to its distance from said guide-plates, substantially in the manner and for the purpose specified.

8. In combination with the guide-plates P P', the cutters C C, projecting from the periphery of their carrying-collar A, substantially as shown and set forth.

In testimony whereof I have hereunto signed my name and affixed my seal, in the presence of two attesting witnesses, at Little Falls, in the county of Herkimer, in the State of New York, this 7th day of July, 1881.

WHITLEY DENTON. [L. S.]

Witnesses:

AMES W. KENFIELD,
SYLVANUS HOLMES.