



## INTERNATIONAL APPLICATION PUBLISHED UNDER THE PATENT COOPERATION TREATY (PCT)

<p>(51) International Patent Classification<sup>6</sup> : <b>A61F 13/56, 13/15</b></p>	<p><b>A1</b></p>	<p>(11) International Publication Number: <b>WO 98/35641</b></p> <p>(43) International Publication Date: 20 August 1998 (20.08.98)</p>
<p>(21) International Application Number: PCT/US97/02096</p> <p>(22) International Filing Date: 18 February 1997 (18.02.97)</p> <p>(71) Applicant (for all designated States except US): THE PROCTER &amp; GAMBLE COMPANY [US/US]; One Procter &amp; Gamble Plaza, Cincinnati, OH 45202 (US).</p> <p>(72) Inventors; and (75) Inventors/Applicants (for US only): SCHAEFER, Markus, Robert [DE/DE]; Im Kleinfeldchen 2, D-53879 Euskirchen (DE). HUBER, Michael, Thomas [US/US]; 4747 Greenwald Court, Cincinnati, OH 45248 (US). WEBER, Josef, Heinz [DE/DE]; Lingscheider Weg 21, D-53902 Bad Muenstereifel (DE).</p> <p>(74) Agents: REED, T., David et al.; The Procter &amp; Gamble Company, 5299 Spring Grove Avenue, Cincinnati, OH 45217 (US).</p>		<p>(81) Designated States: AL, AM, AT, AU, AZ, BA, BB, BG, BR, BY, CA, CH, CN, CU, CZ, DE, DK, EE, ES, FI, GB, GE, HU, IL, IS, JP, KE, KG, KP, KR, KZ, LC, LK, LR, LS, LT, LU, LV, MD, MG, MK, MN, MW, MX, NO, NZ, PL, PT, RO, RU, SD, SE, SG, SI, SK, TJ, TM, TR, TT, UA, UG, US, UZ, VN, YU, ARIPO patent (KE, LS, MW, SD, SZ, UG), Eurasian patent (AM, AZ, BY, KG, KZ, MD, RU, TJ, TM), European patent (AT, BE, CH, DE, DK, ES, FI, FR, GB, GR, IE, IT, LU, MC, NL, PT, SE), OAPI patent (BF, BJ, CF, CG, CI, CM, GA, GN, ML, MR, NE, SN, TD, TG).</p> <p><b>Published</b> With international search report.</p>

(54) Title: DISPOSABLE ABSORBENT ARTICLE WITH FOLDED EAR PANELS AND METHOD OF MAKING SAME

## (57) Abstract

The present invention relates to a means of reproducibly and consistently folding the ear panels on disposable absorbent articles in order to simplify and accelerate the diaper opening process for the user, reduce the risk of potential injury to the end user and wearer caused by clipped ear panels, and create for packaging purposes, a more aesthetically satisfying arrangement in the disposable diaper pack. In another aspect of the invention, a method for the making of a disposable absorbent diaper, which incorporates the folding of the ear panels, is outlined.

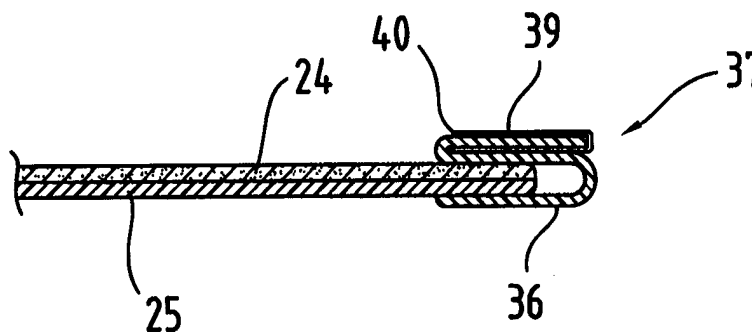

**FOR THE PURPOSES OF INFORMATION ONLY**

Codes used to identify States party to the PCT on the front pages of pamphlets publishing international applications under the PCT.

AL	Albania	ES	Spain	LS	Lesotho	SI	Slovenia
AM	Armenia	FI	Finland	LT	Lithuania	SK	Slovakia
AT	Austria	FR	France	LU	Luxembourg	SN	Senegal
AU	Australia	GA	Gabon	LV	Latvia	SZ	Swaziland
AZ	Azerbaijan	GB	United Kingdom	MC	Monaco	TD	Chad
BA	Bosnia and Herzegovina	GE	Georgia	MD	Republic of Moldova	TG	Togo
BB	Barbados	GH	Ghana	MG	Madagascar	TJ	Tajikistan
BE	Belgium	GN	Guinea	MK	The former Yugoslav Republic of Macedonia	TM	Turkmenistan
BF	Burkina Faso	GR	Greece	ML	Mali	TR	Turkey
BG	Bulgaria	HU	Hungary	MN	Mongolia	TT	Trinidad and Tobago
BJ	Benin	IE	Ireland	MR	Mauritania	UA	Ukraine
BR	Brazil	IL	Israel	MW	Malawi	UG	Uganda
BY	Belarus	IS	Iceland	MX	Mexico	US	United States of America
CA	Canada	IT	Italy	NE	Niger	UZ	Uzbekistan
CF	Central African Republic	JP	Japan	NL	Netherlands	VN	Viet Nam
CG	Congo	KE	Kenya	NO	Norway	YU	Yugoslavia
CH	Switzerland	KG	Kyrgyzstan	NZ	New Zealand	ZW	Zimbabwe
CI	Côte d'Ivoire	KP	Democratic People's Republic of Korea	PL	Poland		
CM	Cameroon	KR	Republic of Korea	PT	Portugal		
CN	China	KZ	Kazakistan	RO	Romania		
CU	Cuba	LC	Saint Lucia	RU	Russian Federation		
CZ	Czech Republic	LI	Liechtenstein	SD	Sudan		
DE	Germany	LK	Sri Lanka	SE	Sweden		
DK	Denmark	LR	Liberia	SG	Singapore		
EE	Estonia						



panels. Clipping tends to occur during the manufacturing cutting phase as a result of the haphazard arrangement of the ear panels on the chassis assembly.

5 The prior art does not reveal any particularly pertinent information on the subject of the folding of ear panels on disposable absorbent articles such as diapers. For example, US 3,863,637 focuses on the folding of a diaper. In particular, the diaper is longitudinally folded into a configuration which in cross-section resembles the Greek symbol sigma on one side of the longitudinal centreline of the diaper and a reverse sigma on the opposite side of the diaper.

10 The diaper has a rectangular outline with adhesive strips being provided on the opposite corners of one end of the diaper. Due to the rectangular shape of the diaper, the issue of ear folding is simply not encountered. In contrast, US 4,050,462 does mention the folding of ear panels. The document describes how a diaper according to the teachings of the invention can be folded and adapted

15 for packaging. The foreshortening of the narrow crotch section as a result of the presence of elastics causes the diaper to fold itself transversely in half, thus enabling the outwardly extending ear panels at the edges of the waistband sections to be easily folded inwards. EP 0 452 951 B1 describes the folding of side sections on a training pants for the purposes of facilitating packaging. In particular, the document relates to a training pants having a front portion, a back portion and side sections connecting both portions together. The side sections extend from the waist opening to the respective leg openings and are folded along a centre line of the training pants extending in the longitudinal direction so that they are positioned between the front portion and the back portion of the

20 training pants. Currently, other disposable diaper products on the market reveal a random arrangement in relation to the folding of ear panels and furthermore, clipped ear panels are very prevalent. This is most pronounced within the disposable diaper packs on opening.

30 As a result of the above prior art attempts, it has been recognised by those skilled in the art that it would be desirable to provide a means of reproducibly and consistently folding the ear panels on disposable diapers in order to simplify and accelerate the diaper opening process for the user, reduce the risk of potential injury to the end user and wearer caused by clipped ear

35 panels, and create for packaging purposes, a more aesthetically satisfying

arrangement in the disposable diaper pack. The solution is found to be ear panels that are multiply folded to create a configuration that exposes the tape tab fastening devices of the ear panels to the user when the diaper has been opened into the semi-folded configuration and that reveals no clipped ears.

5

It has now been discovered that the benefits of the present invention range from an easy one step opening action for the diaper and the tape tab fastening device; to a product with a superior and enhanced appearance due to the neat, controlled and consistent manner of the ear panel folding; to a product that is extremely user friendly and that causes no harm either to the user or to the wearer; to a product that confers a high level of user satisfaction and confidence; and to an arrangement that is most attractive on first impact when the user opens a disposable diaper pack to obtain a diaper. Furthermore, the inclusion of the folding procedure on current manufacturing lines is straightforward. In fact, the folding procedure results in increased reliability, process simplification and permits the elimination of the use of static charging equipment, which poses a safety risk to operators.

10  
15

### **Summary of the invention**

20

In one aspect of the present invention, a disposable absorbent article having a front waist region and a back waist region, a chassis assembly comprising a liquid pervious topsheet and a liquid impervious backsheet joined with the topsheet; an absorbent core positioned between the topsheet and the backsheet; and a pair of ear panels in the back waist region is disclosed. The ear panels comprise a tape tab fastening device comprising an attachment area and a functional area. Each of the ear panels is folded backwards onto itself to at least the width of the attachment area of the tape tab fastening device and subsequently is folded forward onto itself to at least once the width of the attachment area of the tape tab fastening device. The portion of the ear panel after forward folding not comprising the attachment area of the tape tab fastening device is disposed in a configuration partially overlapping the attachment area of the tape tab fastening device. In a preferred embodiment of the present invention, each of the ear panels is folded forward onto itself to twice the width of the attachment area of the tape tab fastening device. The ear panels can be

25

30

either unitary with the back waist region of the diaper or joined along a line of juncture to same.

5 In another aspect of the present invention, a method of making a disposable diaper with the features described above is disclosed. The steps comprise providing a disposable diaper; folding each of the ear panels backwards onto itself to at least the width of the attachment area of the tape tab fastening device; folding each of the ear panels forward onto itself to at least once the width of the attachment area of the tape tab fastening device; folding  
10 each portion of the ear panels after forward folding not comprising the attachment area of the tape tab fastening device into a configuration that partially overlaps the attachment area of the tape tab fastening device. In another preferred embodiment of the present invention, the ear panels are joined along a line of juncture to the back waist region before the forward folding step  
15 occurs.

#### **Brief description of the drawings**

It is believed that the invention will be better understood from the foregoing description in conjunction with the accompanying drawings in which:

20

Figure 1 is a plan view of a disposable diaper embodiment of the present invention having portions cut away to reveal the underlying structure with the outer surface of the diaper facing the viewer;

25

Figure 2a is a cross-sectional view through line A-A in Figure 1 of the preferred disposable diaper embodiment ;

Figure 2b is a continuation from Figure 2a after the ear panel has been folded backward onto itself;

30

Figure 2c is a continuation from Figure 2b after the ear panel has been folded forwarded onto itself to at least once the width of the attachment area of the fastening device;

Figure 3a is a preferred embodiment of the present invention and is a continuation from Figure 2c. In this embodiment, the ear panel has been folded forwarded onto itself to twice the width of the attachment area of the tape tab fastening device.

5

Figure 3b is a continuation from Figure 3a and shows the fully folded configuration of the ear panel.

### Detailed description of the invention

10 As used herein, the term "disposable absorbent article" refers to articles which absorb and contain body exudates; and more specifically, refers to articles which are placed against or in proximity to the body of the wearer to absorb and contain the various exudates discharged from the body and which are intended to be discarded after a single use (i.e., they are not intended to be laundered or  
15 otherwise restored or reused) and, preferably, to be recycled, composted or otherwise disposed of in an environmentally compatible manner. As used herein, the term "diaper" refers to a garment generally worn by infants or incontinence sufferers that is drawn up between the legs and fastened about the waist of the wearer. The term "panel" is used herein to denote an area or  
20 element of the waist feature or the diaper. (While a panel is typically a distinct area or element, a panel may overlap somewhat with an adjacent panel.) As used herein, the term "joined" encompasses configurations whereby an element is directly secured to the other element by affixing the element directly to the other element, and configurations whereby the element is indirectly secured to  
25 the other element by affixing the element to an intermediate member(s) which in turn is affixed to the other element.

Figure 1 is a plan view of the diaper 20 of the present invention in its flat-out, uncontracted state (i.e., with elastic induced contraction pulled out) with  
30 portions of the structure being cut away to more clearly show the construction of the diaper 20 and with the portion of the diaper 20 that faces away from the wearer, the outer surface, facing the viewer. As shown in Figure 1, the diaper 20 has a generally "T-shape" and comprises  
a chassis assembly 22 comprising a liquid pervious topsheet 24, a liquid  
35 impervious backsheet 26 joined with the topsheet 24, an absorbent core 28

positioned between the topsheet 24 and the backsheet 26; extensible leg cuffs 30 each comprising a leg flap panel 31 and one or more elastic members, elastic strands 54, operatively joined with the leg flap panel 31; an extensible back waist feature 32 comprising a central waistband panel 34, a pair of ear panels 36, each comprising a tape tab fastening device 37, and a hip panel 38; a landing member for tape tab fastening device 37; and an extensible front waist feature 42 comprising a front waist panel 43.

Each of the panels may be a separate member joined to the overall diaper structure or may be unitary with the diaper 20 in that they comprise an extension of other elements of the diaper such as the topsheet 24, the backsheet 26, or both. In the embodiment shown in Figure 1, all of the panels except for the ear panels 36 comprise an extension of the topsheet 24 and the backsheet 26. The ear panels 36 comprise a separate member joined to the central waistband panel 34 and at least a portion of the hip panel 38. Further, any or all of the panels may be extensible. The chassis panel 22 is typically not extensible in order to maintain the integrity of the absorbent core 28 during use, although it may be rendered extensible such as by being formed as a structural elastic-like film (SELF) web as described herein. Preferably, the extensible panels comprise a SELF web. The use of a SELF web allows the force/extension properties of each of the panels to be specifically designed to maximise the fit and containment of the diaper with a minimum amount of materials (no conventional elastic materials are needed).

As is evident from Figure 1, the diaper 20 is provided with a closure system comprising a tape tab fastening device 37 and a landing member 41 for fitting the diaper 20 on the wearer. The tape tab fastening device 37 comprises an attachment area 39 and a functional area (not shown), and the landing member, is preferably a reinforcing strip 41 or, the alternative, a portion of the backsheet 26, positioned in the front waist region 45 of the diaper 20. The attachment area 39 is the area on the tape tab fastening device 37 that is joined to the ear panel 36 and the functional area is the area on the tape tab fastening device 37 on which functional elements are located to permit engagement with the landing member on the front waist region 45 of the diaper. The functional elements may take on a number of configurations such as adhesive fastening elements,

mechanical fastening elements, a combination of adhesive fastening elements and mechanical fastening elements, or any other means as are known to the man skilled in the art.

5           The diaper 20 of Figure 1 has an inner surface (not shown), an outer surface 44 (facing the viewer in Figure 1) opposed to the inner surface, a front waist region 45, a back waist region 46 opposed to the front waist region 45, and a periphery which is defined by the outer edges of the diaper 20 in which the longitudinal edges are designated 47 and the end edges are designated 48.  
10 (While the man skilled in the art will recognise that a diaper is usually described in terms of having a pair of waist regions and a crotch region between the waist regions; in this application, for simplicity of terminology, the diaper 20 is described as having only waist regions, each of the waist regions including a portion of the diaper which would typically be designated as part of the crotch region). The inner surface of the diaper 20 comprises that portion of the diaper 20 which is positioned adjacent to the body of the wearer during use (i.e., the inner surface generally is formed by at least a portion of the topsheet 24 and other components joined to the topsheet 24). The outer surface 44 comprises that portion of the diaper 20 which is positioned away from the body of the  
15 wearer (i.e., the outer surface 44 generally is formed by at least a portion of the backsheet 26 and other components joined to the backsheet 26). The front waist region 45 and the back waist region 46 extend, respectively, from the end edges 48 of the periphery to the lateral centreline 49 of the diaper 20. (The lateral direction (x direction or width) is defined as the direction parallel to the lateral centreline 49 of the diaper 20; the longitudinal direction (y direction or length) being defined as the direction parallel to the longitudinal centreline 50; and the axial direction (z direction or thickness) being defined as the direction extending through the thickness of the diaper 20.)  
20  
25

30           Figure 1 shows a preferred embodiment of the diaper 20 in which the topsheet 24 and the backsheet 26 have length and width dimensions generally larger than those of the absorbent core 28. The topsheet 24 and the backsheet 26 extend beyond the edges of the absorbent core 28 to thereby form certain of the panels and portions of the periphery of the diaper. The periphery defines the

outer perimeter or, in other words, the edges of the diaper 20. The periphery comprises the longitudinal edges 47 and the end edges 48.

The chassis assembly 22 (chassis panel) of the diaper 20 is shown in Figure 1 as comprising the main body (chassis) of the diaper 20. The chassis assembly 22 comprises at least an absorbent core 28, preferably an outer covering layer comprising the topsheet 24 and the backsheet 26. Thus, the chassis assembly 22 comprises the main structure of the diaper with other features added to form the composite diaper structure. An exemplary example of a chassis assembly of the present invention is described in US 3,860,003.

The absorbent core 28 may be any absorbent means which is capable of absorbing and retaining liquids such as urine and other certain body exudates. The absorbent core 28 has a garment surface, a body surface, side edges 57, and waist edges 56. The absorbent core 28 may be manufactured in a wide variety of sizes and shapes (e.g., rectangular, hourglass, "T"-shaped, asymmetric, etc.) and from a wide variety of liquid-absorbent materials commonly used in disposable diapers and other absorbent articles such as comminuted wood pulp which is generally referred to as airfelt. Examples of other suitable absorbent materials include creped cellulose wadding, meltblown polymers including coform, cross-linked cellulose fibers, tissue including tissue wraps and tissue laminates, absorbent foams, absorbent sponges, superabsorbent polymers, absorbent gelling materials, or any equivalent material or combinations of materials. The configuration and construction of the absorbent core 28 may also be varied (e.g., the absorbent core 28 may have varying caliper zones, a hydrophilic gradient, a superabsorbent gradient, or lower average density and lower average basis weight acquisition zones; or may comprise one or more layers or structures). The total absorbent capacity of the absorbent core 28 should, however, be compatible with the design loading and the intended use of the diaper 20. Further, the size and absorbent capacity of the absorbent core 28 may be varied to accommodate wearers ranging from infants through adults. An absorbent structure useful as the absorbent core 28 of the present invention that has achieved wide acceptance and commercial success is described in US 4,610,678. US 4,673,402; US 4,888,231; US Patent 5,147,345; US 5,102,597; and US 4,834,735; also describe absorbent structures

that are useful in the present invention. The absorbent core 28 is preferably the dual-layer absorbent structure described in US 5,234,423 .

5 The backsheet 26 is positioned adjacent the garment surface of the absorbent core 28 and is preferably joined thereto by attachment means (not shown) such as those well known in the art. For example, the backsheet 26 may be secured to the absorbent core 28 by a uniform continuous layer of adhesive, a patterned layer of adhesive, or an array of separate lines, spirals, or spots of adhesive. Adhesives which have been found to be satisfactory are  
10 manufactured by H. B. Fuller Company of St. Paul, Minnesota and marketed as HL-1258. The attachment means will preferably comprise an open pattern network of filaments of adhesive as is disclosed in US 4,573,986. An exemplary attachment means of an open pattern network of filaments comprises several lines of adhesive filaments swirled into a spiral pattern such as is illustrated by  
15 the apparatus and methods shown in US 3,911,173; US 4,785,996; and US 4,842,666. Alternatively, the attachment means may comprise heat bonds, pressure bonds, heat/pressure bonds, ultrasonic bonds, dynamic mechanical bonds, or any other suitable attachment means or combinations of these attachment means as are known in the art. The backsheet 26 is impervious to  
20 liquids (e.g., urine) and is preferably manufactured from a thin plastic film, although other flexible liquid impervious materials may also be used. As used herein, the term "flexible" refers to materials which are compliant and will readily conform to the general shape and contours of the human body. The backsheet 26 prevents the exudates absorbed and contained in the absorbent core 28 from  
25 wetting articles which contact the diaper 20 such as bedsheets and undergarments. The backsheet 26 may thus comprise a woven or nonwoven material, polymeric films such as thermoplastic films of polyethylene or polypropylene, or composite materials such as a film-coated nonwoven material. Preferably, the backsheet is a thermoplastic film having a thickness of from  
30 about 0.012 millimetres to about 0.051 millimetres. The backsheet 26 preferably comprises a polyethylene blend film of about 0.025 millimetres as is manufactured by Tredegar Corporation of Terre Haute, IN and marketed as P8863.

The topsheet 24 is positioned adjacent the body surface of the absorbent core 28 and is preferably joined thereto and to the backsheet 26 by attachment means (not shown) such as those well known in the art. Suitable attachment means are described with respect to joining the backsheet 26 to the absorbent core 28. In a preferred embodiment of the present invention, the topsheet 24 and the backsheet 26 are joined directly to each other in the diaper periphery and are indirectly joined together by directly joining them to the absorbent core 28 by the attachment means (not shown). The topsheet 24 is compliant, soft feeling, and non-irritating to the wearer's skin. Further, the topsheet 24 is liquid pervious permitting liquids (e.g., urine) to readily penetrate through its thickness. A suitable topsheet may be manufactured from a wide range of materials, such as porous foams; reticulated foams; apertured plastic films; or woven or nonwoven webs of natural fibres (e.g., wood or cotton fibres), synthetic fibres (e.g., polyester or polypropylene fibres), or a combination of natural and synthetic fibres. Preferably, the topsheet 24 is made of a hydrophobic material to isolate the wearer's skin from liquids which have passed through the topsheet and are contained in the absorbent core 28 (i.e., to prevent rewet). If the topsheet 24 is made of a hydrophobic material, at least the upper surface thereof is treated to be hydrophilic so that liquids will transfer through the topsheet 24 more rapidly. This diminishes the likelihood that body exudates will flow off the topsheet 24 rather than being drawn through the topsheet 24 and being absorbed by the absorbent core 28. The topsheet 24 can be rendered hydrophilic by treating it with a surfactant. Suitable methods for treating the topsheet 24 with a surfactant include spraying the material with the surfactant and immersing the material in the surfactant. A more detailed discussion of such a treatment and hydrophilicity is contained in US 4,988,344.

The diaper 20 preferably further comprises extensible leg cuffs 30 for providing improved containment of liquids and other body exudates. Each extensible leg cuff 30 may comprise several different embodiments for reducing the leakage of body exudates in the leg regions. (The leg cuff can be and is sometimes also referred to as leg bands, leg flaps, barrier cuffs, or elastic cuffs.) US 3,860,003 describes a disposable diaper which provides a contractible leg opening having a leg flap and one or more elastic members to provide an elasticized leg cuff (gasketing cuff). US 4,909,803, describes a disposable

diaper having "stand-up" elasticized flaps (barrier cuffs) to improve the containment of the leg regions. US 4,695,278 describes a disposable diaper having dual cuffs including a gasketing cuff and a barrier cuff. US 4,704,115 discloses a disposable diaper or incontinent garment having side-edge-leakage-guard gutters configured to contain free liquids within the garment. US 5,032,120 discloses an absorbent article having leg cuffs having a relatively low ultimate contact force at relatively high elongations accomplished, for example, by low contact force differential material. US 5,087,255 discloses an absorbent article having inflected barrier cuffs with the distal edge positioned outboard of the proximal edge in one waist region and inboard in the other to provide better fit about the hips/buttocks. While each extensible leg cuff 30 may be configured so as to be similar to any of the leg bands, leg flaps, barrier cuffs, or elastic cuffs described above, as shown in Figure 1, each extensible leg cuff 30 comprises the leg flap panel 31 extending laterally outwardly from the chassis panel 22, the side edge 57 of the absorbent core 28, and one or more elastic members, elastic strands 54, operatively joined with the leg flap panel 31, such as is described in US 3,860,003.

The diaper 20 further comprises extensible waist features that provide improved fit and containment. The extensible waist features at least extend longitudinally outwardly from the chassis assembly, preferably a respective waist edge 56 of the absorbent core 28, and generally form at least a portion of the end edge 48 of the diaper 20. Thus, in the embodiment shown in Figure 1, the extensible back waist feature 32 comprises that portion of the diaper 20 extending from the waist edge 56 of the absorbent core 28 in the back waist region 46 to the end edge 48 of the diaper 20. While a disposable diaper 20 of the present invention is constructed with an extensible waist feature disposed in each waist region (an extensible back waist feature 32 and an extensible front waist feature 42), the discussion will focus on diapers having different configurations for each extensible waist feature. At a minimum, it is preferred that the diaper 20 have at least one of the extensible waist features constructed according to the present invention, more preferably at least the back extensible waist feature 32. The waist features can be constructed as a separate element joined to the chassis assembly 22 or as an extension of other elements of the diaper (i.e., unitary). The waist features will be described with respect to

preferred embodiments in which certain portions or panels comprise an extension of other elements of the diaper such as the backsheet 26, the topsheet 24, or both, and other portions or panels comprise a separate element joined to other portions or panels of the waist feature or other panels of the diaper.

5

The extensible back waist feature 32 provides an extensible member that provides a more comfortable and contouring fit by initially conformably fitting the diaper to the wearer and sustaining this fit throughout the time of wear well past when the diaper has been loaded with exudates since the extensible back waist feature 32 allows the diaper to expand and, preferably, to contract. Further, the extensible back waist feature 32 develops and maintains wearing forces (tensions) that enhance the tensions developed and maintained by the closure system to maintain the diaper on the wearer and that enhance the fit of the diaper about the waist of the wearer. The extensible back waist feature 32 further provides more effective application of the diaper since even if the diaperer pulls one side (ear panel 36) of the extensible back waist feature 32 farther than the other during application (asymmetrically), the diaper will "self-adjust" during wear. As shown in Figure 1, the extensible back waist feature 32 comprises a central waistband panel 34; a pair of ear panels 36; and a hip panel 38. In the embodiment shown in Figure 1, the hip panel 38 is disposed longitudinally outwardly from the chassis assembly 22 (the chassis panel), preferably from the waist edge 56 of the absorbent core 28, in the middle zone of the back waist region 46; the central waistband panel 34 is disposed longitudinally outwardly from the hip panel 38; and the side panels 36 are each disposed laterally outwardly from the central waistband panel 34 and at least a portion of the hip panel 38. As discussed hereinafter, the particular positioning of each panel of the back waist feature is important to the overall functioning of the back waist feature.

The ear panels 36 are those portions of the extensible back waist feature 32 that extend laterally outwardly from the central waistband panel 34 and at least a portion of the hip panel 38. The ear panels 36 are each an extensible member that primarily function to provide a more comfortable and contouring fit by initially conformably fitting the diaper 20 to the wearer at application and sustaining this fit throughout the time of wear well past when the diaper 20 has

35

been loaded with exudates by enlarging the circumference of the diaper 20 at the sides, attaching the back waist region 46 to the front waist region 45 of the diaper 20 to complete a closure for the diaper 20, and distributing forces along both the waist and legs to transfer these forces such that there is a snug fit with no skin irritation due to excessive forces on the legs or the waist. The ear panels 36 provide stretch as well as, in preferred embodiments, a contractive force after extension and application. Thus, the ear panels 36 provide a more comfortable and contouring fit by allowing the sides of the diaper to expand and contract. The ear panels 36 also develop and maintain wearing forces (tensions) and enhance the tensions developed and maintained by the tape tab fastening device 37 and landing member to maintain the diaper 20 on the wearer and enhance the fit. The ear panels 36 assist in maintaining the primary line of tension formed by the primary fastening system; allowing the diaper to conformably fit over the hips of the wearer where there is dynamic motion, and initially pretensioning the front extensible waist feature, if provided on the diaper 20, since the diaper 20 typically stretches the ear panels 36 when applying the diaper on the wearer so that when the ear panels 36 contract, tension is transmitted from the ear panels 36 through the tape tab fastening device 37 and landing member 41 into the extensible front waist feature 42. The ear panels 36 further provide more effective application of the diaper 20 since even if the user pulls one ear panel 36 farther than the other during application, the diaper 20 will "self-adjust" during wear.

The ear panels 36 may have a number of different sizes and shapes. For example, the ear panels 36 may each have an arcuate shape so that forces transmitted through the ear panel 36 are along a line or zone disposed at an angle to the body of the wearer to fit the diaper into the lumbar curve of the back and to allow the tensional forces (the primary line of tension) to be directed downward toward the abdominal crease of the wearer so as to provide a continuous primary line of tension. Examples of such side panels are described in US Patent Application Serial No. 08/072,300; and US Patent Application Serial No. 08/155,048 . The ear panels 36 have a rectangular shape in Figure 1. For a typical "large" (8 kg to 14 kg) baby diaper, the ear panels 36 may, for example, have a size of about 63 mm in the lateral direction by about 57 mm in the longitudinal direction.

The ear panels 36 may be constructed in a number of configurations and from a number of different materials. Examples of diapers with elasticized side panels are disclosed in US 4,857,067; US 4,381,781; US 4,938,753; and US 5,151,091. Thus, the ear panels 36 may comprise conventional elastic materials or mechanically stretched laminates such as a zero strain stretch laminate or a SELF web. The ear panels 36 may comprise a separate element affixed to the back waist feature 32 at the central waistband panel 34 and the hip panel 38, or can be constructed as an extension of other elements of the back waist feature 32 or the diaper 20 such as the backsheet 26 or the topsheet 24, preferably both the topsheet 24 and the backsheet 26. In the embodiment of the present invention shown in Figure 1, the ear panels 36 each comprise a separate SELF web joined to the back waist feature 32 (the central waistband panel 34 and the hip panel 38). The SELF web of the ear panels 36 preferably comprises a laminate of two or more layers, preferably two layers; most preferably a laminate of a layer of a polyethylene blend film such as is marketed by Clopay Corporation of Cincinnati, Ohio as Clopay 1401 and a nonwoven web such as P-8 material.

Figure 2a is a cross sectional view through line A-A in Figure 1 of the preferred disposable diaper embodiment. In more detail, Figure 2a shows only a portion of the topsheet 24, a portion of the backsheet 26, an ear panel 36 and a tape tab fastening device 37. The attachment area 39 of the tape tab fastening device 37 is visible. In the embodiment shown in Figure 2a, the ear panel 36 is joined to and extends laterally outwards from the back waist region 46. In Figure 2a, the ear panel 36 is joined to the backsheet 26, but may equally be joined to the topsheet 24. The ear panel 36 may equally be a unitary part of the disposable diaper 20. Figure 2b is a continuation from Figure 2a. The ear panel 36 is folded backwards onto itself to at least the width of the attachment area 39 of the tape tab fastening device 37. The edge 40 of the attachment area 39 of the tape tab fastening device 37 can serve as a useful reference line for folding. During the process, knife welds (not shown) hold the folded ear panels 36 in place until the disposable diaper 20 has been packaged. In Figure 2c, the ear panel 36 is subsequently folded forward onto itself to at least once the width of the attachment area 39 of the tape tab fastening device 37.

Figure 3a is a preferred embodiment of the present invention and is a continuation from Figure 2c. In this preferred embodiment, the ear panel 36 is folded forward onto itself to twice the width of the attachment area 39 of the tape tab fastening device 37. Figure 3b is a continuation from Figure 3a and shows the fully folded configuration of the ear panel 36, as desired by the present invention. In particular, the portion P of the ear panel 36 after forward folding not comprising the attachment area 39 of the tape tab fastening device 37 is disposed in a configuration partially overlapping the attachment area 39 of the tape tab fastening device 37. In another preferred embodiment of the present invention, each of the ear panels 36 is joined along a line of juncture to the back waist region 46. This is apparent from Figure 1.

In another aspect of the present invention, the making of a disposable diaper 20 is disclosed. Figures 1, 2a, 2b, 2c, 3a and 3b are relevant. The method comprises the steps of (a) providing a diaper 20 comprising a front waist region 45 and a back waist region 46, a chassis assembly 22 comprising a liquid pervious topsheet 24 and a liquid impervious backsheet 26 joined to the topsheet 24; an absorbent core 28 positioned between the topsheet 24 and the backsheet 26; and a pair of ear panels 36 in the back waist region 46, the ear panels 36 comprising a tape tab fastening device 37 comprising an attachment area 39 and a functional area (not shown); (b) folding each of the ear panels 36 backwards onto itself to at least the width of the attachment area 39 of the tape tab fastening device 37; (c) folding each of the ear panels 36 forward onto itself to at least once the width of the attachment area 39 of the tape tab fastening device 37; (d) folding each portion of the ear panels 36 after forward folding not comprising the attachment area 39 of the tape tab fastening device 37 into a configuration that partially overlaps the attachment area 39 of the tape tab fastening device 37. In a preferred embodiment of the method, step (c) includes folding each of the ear panels 36 forward onto itself to twice the width of the attachment area 39 of the tape tab fastening device 37. In another preferred embodiment of the present invention, the ear panels 36 each comprise a web joined to the back waist feature 32 and step (b) occurs before the joining of the ear panels 36 to the back waist region 46 of the diaper 20 at a line of juncture 58. As used herein, the term "juncture" refers to regions where panels extend

from or are joined to the chassis assembly 22. These regions can be any of various curved or straight lines, but they are not limited to lines. Thus, these regions can comprise flanges, strips, intermittent lines and the like.

**CLAIMS**

5

1. Disposable absorbent article (20) having a front waist region (45) and a back waist region (46), said absorbent article (20) comprising:  
a chassis assembly (22) comprising a liquid pervious topsheet (24) and a liquid impervious backsheet (26) joined with said topsheet (24);

10 an absorbent core (28) positioned between said topsheet (24) and said backsheet (26); and a pair of ear panels (36) in said back waist region (46), each of said ear panels (36) comprising a tape tab fastening device (37) comprising an attachment area (39) and a functional area;  
characterised in that

15 each of said ear panels (36) is folded backwards onto itself to at least the width of said attachment area (39) of said tape tab fastening device (37); and subsequently is folded forward onto itself to at least once said width of said attachment area (39) of said tape tab fastening device (37).

20 2. Disposable absorbent article (20) according to claim 1 wherein each of said ear panels (36) is folded forward onto itself to twice said width of said attachment area (39) of said tape tab fastening device (37).

25 3. Disposable absorbent article (20) according to any of the preceding claims wherein portion (P) of said ear panel (36) after forward folding not comprising said attachment area (39) of said tape tab fastening device (37) is disposed in a configuration partially overlapping said attachment area (39) of said tape tab fastening device (37).

30 4. Disposable absorbent article (20) according to any of the preceding claims wherein said functional area of said tape tab fastening device (37) comprises an adhesive fastening element.

5. Disposable absorbent article (20) according to any of the preceding claims wherein said functional area of said tape tab fastening device (37) comprises a mechanical fastening element.

5 6. Disposable absorbent article (20) according to claim 1 wherein each of said ear panels (36) is joined along a line of juncture (58) to said back waist region (46).

7. Method of making a disposable diaper (20) wherein said method  
10 comprises the steps of:

(a) providing a disposable diaper (20) comprising a front waist region (45) and a back waist region (46), a chassis assembly (22) comprising a liquid pervious topsheet (24) and a liquid impervious backsheet (26) joined to said topsheet (24); an absorbent core (28) positioned between said topsheet (24) and  
15 said backsheet (26); and a pair of ear panels (36) in said back waist region (46), said ear panels (36) comprising a tape tab fastening device (37) comprising an attachment area (39) and a functional area;

(b) folding each of said ear panels (36) backwards onto itself to at least said width of said attachment area (39) of said tape tab fastening device (37);

20 (c) folding each of said ear panels (36) forward onto itself to at least once said width of said attachment area (39) of said tape tab fastening device (37);

(d) folding each portion (P) of said ear panels (36) after forward folding not comprising said attachment area (39) of said tape tab fastening device (37) into a configuration that partially overlaps said attachment area (39) of said tape tab  
25 fastening device (37).

8. Method according to claim 7 wherein said step (c) includes folding each of said ear panels (36) forward onto itself to twice said width of said attachment area (39) of said tape tab fastening device (37).

30

9. Method according to claim 8 wherein step (b) occurs before joining of said ear panels (36) to said back waist region (46) at a line of juncture (58).

35

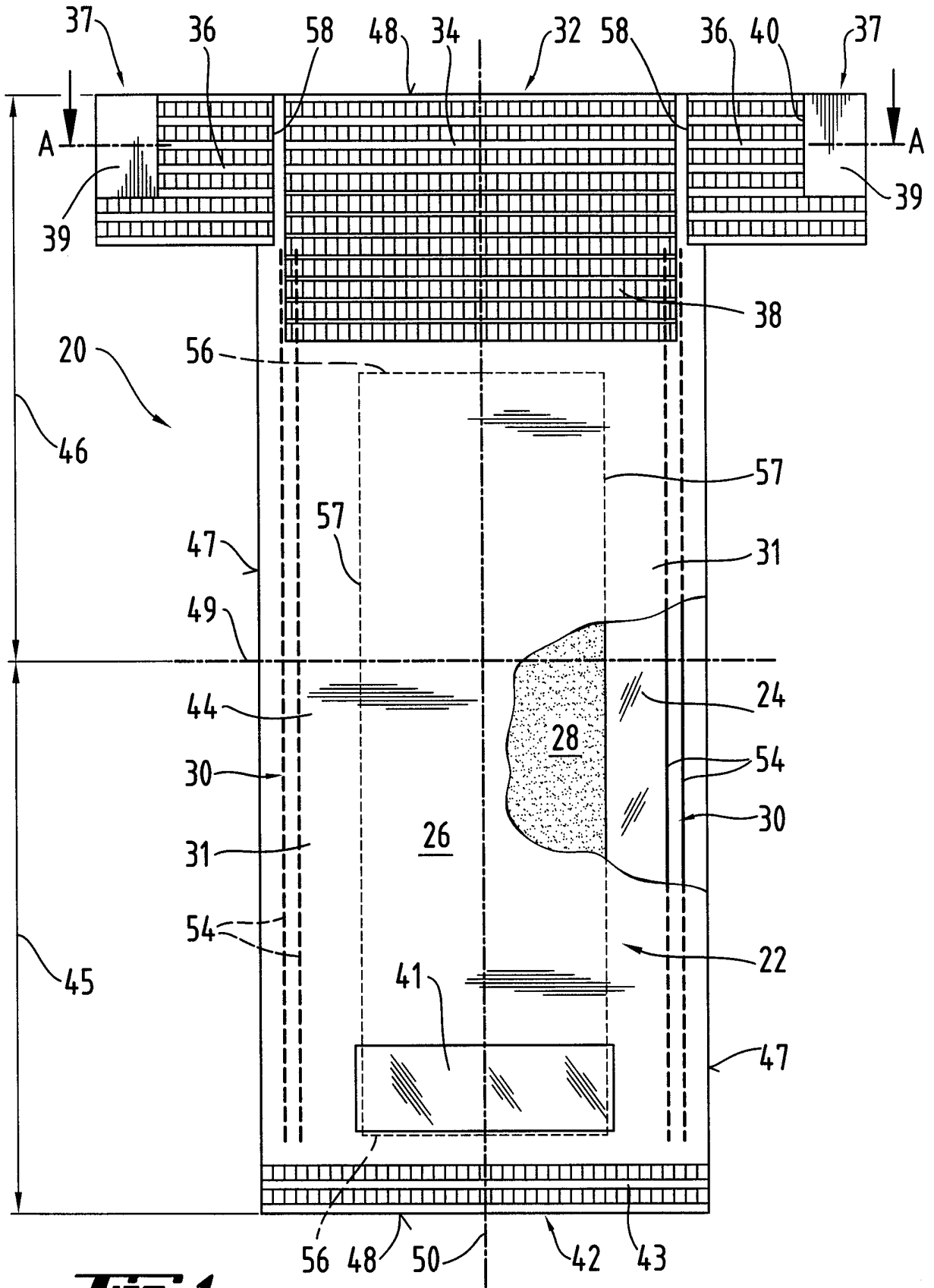

**Fig. 1**

2/2

**Fig. 2 a**

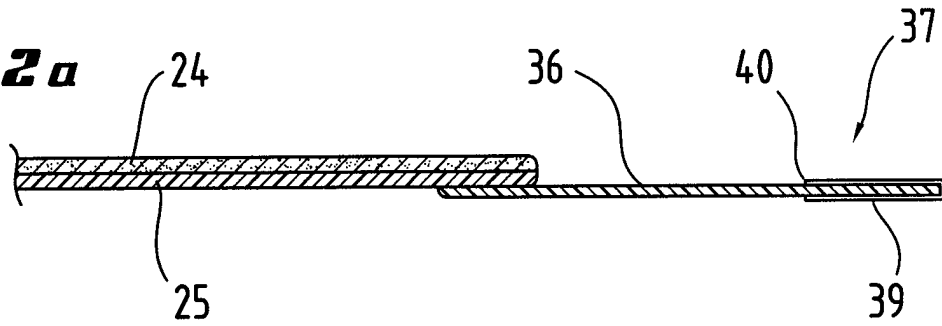

**Fig. 2 b**

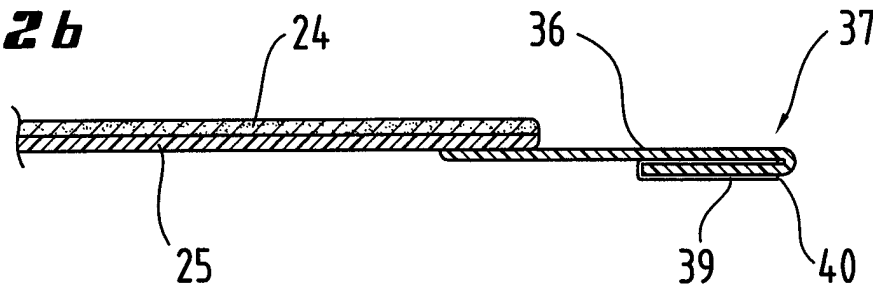

**Fig. 2 c**

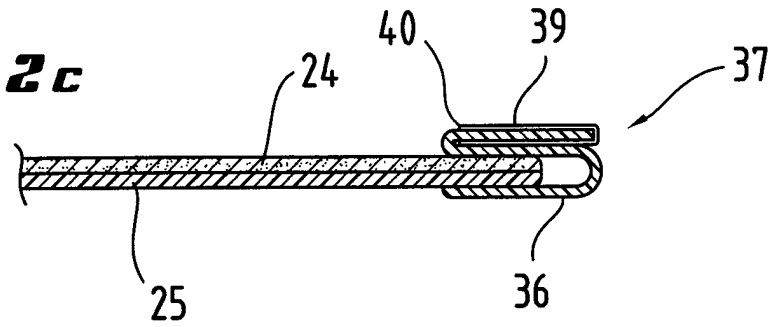

**Fig. 3 a**

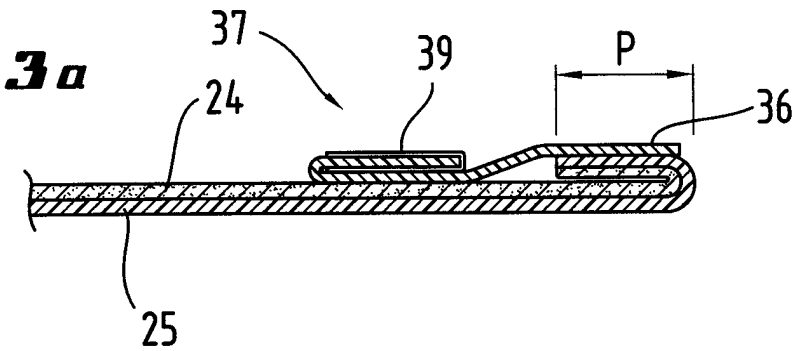

**Fig. 3 b**

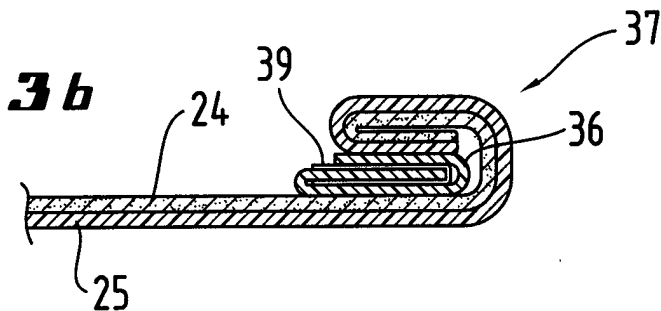

# INTERNATIONAL SEARCH REPORT

International Application No

PCT/US 97/02096

<b>A. CLASSIFICATION OF SUBJECT MATTER</b> IPC 6 A61F13/56 A61F13/15		
According to International Patent Classification (IPC) or to both national classification and IPC		
<b>B. FIELDS SEARCHED</b>		
Minimum documentation searched (classification system followed by classification symbols) IPC 6 A61F		
Documentation searched other than minimum documentation to the extent that such documents are included in the fields searched		
Electronic data base consulted during the international search (name of data base and, where practical, search terms used)		
<b>C. DOCUMENTS CONSIDERED TO BE RELEVANT</b>		
Category °	Citation of document, with indication, where appropriate, of the relevant passages	Relevant to claim No.
X	WO 84 04242 A (JOHNSON & JOHNSON PROD INC) 8 November 1984 see page 3, line 31 - page 4, line 6; claim 1; figures 1,4 ---	1,2,4,6
X	US 4 084 592 A (TRITSCH LUDWIG) 18 April 1978 see column 3, line 57 - column 4, line 29; claims 5,8,11,12; figures	1,4
A	---	2,7
X	FR 2 267 058 A (SCHICKEDANZ VER PAPIERWERK) 7 November 1975 see page 3, line 37 - page 4, line 4; claim 1; figure 2 ---	1,4
--- -/--		
<input checked="" type="checkbox"/> Further documents are listed in the continuation of box C.		
<input checked="" type="checkbox"/> Patent family members are listed in annex.		
° Special categories of cited documents :		
*A* document defining the general state of the art which is not considered to be of particular relevance *E* earlier document but published on or after the international filing date *L* document which may throw doubts on priority claim(s) or which is cited to establish the publication date of another citation or other special reason (as specified) *O* document referring to an oral disclosure, use, exhibition or other means *P* document published prior to the international filing date but later than the priority date claimed		
*T* later document published after the international filing date or priority date and not in conflict with the application but cited to understand the principle or theory underlying the invention *X* document of particular relevance; the claimed invention cannot be considered novel or cannot be considered to involve an inventive step when the document is taken alone *Y* document of particular relevance; the claimed invention cannot be considered to involve an inventive step when the document is combined with one or more other such documents, such combination being obvious to a person skilled in the art. *&* document member of the same patent family		
Date of the actual completion of the international search  <div style="text-align: center; font-size: 1.2em;">16 October 1997</div>		Date of mailing of the international search report  <div style="text-align: center; font-size: 1.2em;">28. 10. 97</div>
Name and mailing address of the ISA European Patent Office, P.B. 5818 Patentlaan 2 NL - 2280 HV Rijswijk Tel. (+31-70) 340-2040, Tx. 31 651 epo nl, Fax: (+31-70) 340-3016		Authorized officer  <div style="text-align: center; font-size: 1.2em;">Mirza, A</div>

1

INTERNATIONAL SEARCH REPORT

International Application No

PCT/US 97/02096

C.(Continuation) DOCUMENTS CONSIDERED TO BE RELEVANT

Category °	Citation of document, with indication, where appropriate, of the relevant passages	Relevant to claim No.
X	DE 34 40 544 A (HERMANN GMBH CO HEINRICH) 7 May 1986 see claims 1,2; figures ---	1,4
A	US 4 670 012 A (JOHNSON NORDAHL K) 2 June 1987 see column 5, line 35 - line 39; claim 1; figures 7,9 ---	1,4,6
A	WO 95 22951 A (PROCTER & GAMBLE) 31 August 1995 see page 38, line 34 - page 39, line 19; claims 1,12; figure 18 ---	1,5,6
A	US 3 930 502 A (TRITSCH LUDWIG) 6 January 1976 see claims 1,2; figures ---	1,4
A	WO 95 35079 A (PROCTER & GAMBLE) 28 December 1995 see claims 1,5,6,10 -----	7,9

# INTERNATIONAL SEARCH REPORT

Information on patent family members

International Application No  
PCT/US 97/02096

Patent document cited in search report	Publication date	Patent family member(s)	Publication date
WO 8404242 A	08-11-84	AU 2824584 A DK 609084 A EP 0143810 A	19-11-84 18-12-84 12-06-85
-----			
US 4084592 A	18-04-78	NONE	
-----			
FR 2267058 A	07-11-75	DE 2418209 A AT 343572 B BE 827847 A CH 590024 A LU 72276 A NL 7503923 A	23-10-75 12-06-78 31-07-75 29-07-77 20-08-75 15-10-75
-----			
DE 3440544 A	07-05-86	NONE	
-----			
US 4670012 A	02-06-87	NONE	
-----			
WO 9522951 A	31-08-95	US 5554145 A AU 1746395 A CA 2182873 A CN 1144472 A CZ 9602469 A EP 0748197 A FI 963355 A NO 963555 A US 5556394 A US 5554143 A US 5569232 A US 5554144 A	10-09-96 11-09-95 31-08-95 05-03-97 15-01-97 18-12-96 28-08-96 25-10-96 17-09-96 10-09-96 29-10-96 10-09-96
-----			
US 3930502 A	06-01-76	NONE	
-----			
WO 9535079 A	28-12-95	US 5487809 A AU 2703495 A CA 2192323 A EP 0766547 A FI 965168 A NO 965485 A US 5578152 A US 5620432 A	30-01-96 15-01-96 28-12-95 09-04-97 20-12-96 21-02-97 26-11-96 15-04-97

# INTERNATIONAL SEARCH REPORT

Information on patent family members

International Application No

PCT/US 97/02096

Patent document cited in search report	Publication date	Patent family member(s)	Publication date
WO 9535079 A		ZA 9505103 A	16-04-96
-----			