

(19) World Intellectual Property Organization
International Bureau



(43) International Publication Date
8 February 2007 (08.02.2007)

PCT

(10) International Publication Number
WO 2007/016409 A1

- (51) **International Patent Classification:**
A61F 2/92 (2006.01)
- (21) **International Application Number:**
PCT/US2006/029566
- (22) **International Filing Date:** 28 July 2006 (28.07.2006)
- (25) **Filing Language:** English
- (26) **Publication Language:** English
- (30) **Priority Data:**
11/196,800 2 August 2005 (02.08.2005) US
- (71) **Applicant (for all designated States except US):** REVA MEDICAL, INC. [US/US]; 5751 Copley Drive, Suite B, San Diego, California 92111 (US).
- (72) **Inventors; and**
- (75) **Inventors/Applicants (for US only):** SCHMID, Eric, V. [US/US]; 12248 Meadow Grass Ct., San Diego, California 92128 (US). NGUYEN, John, D. [US/US]; 14340 El Vestido St., San Diego, California 92129 (US). PADILLA, Orlando [US/US]; 24582 Via Carissa, Laguna Niguel, California 92677-7039 (US). MORRIS, Andrew [US/US];

7924 Valdosta Ave., San Diego, California 92126 (US). MOORE, Daniel [US/US]; 12618 Futura St., San Diego, California 92130 (US). JACKSON, Thomas, R. [US/US]; 7135 Olivetas Ave., La Jolla, California 92037 (US).

(74) **Agent:** DELANEY, Karoline, A.; Knobbe, Martens, Olson & Bear, LLP, 2040 Main Street, 14th Floor, Irvine, California 92614 (US).

(81) **Designated States (unless otherwise indicated, for every kind of national protection available):** AE, AG, AL, AM, AT, AU, AZ, BA, BB, BG, BR, BW, BY, BZ, CA, CH, CN, CO, CR, CU, CZ, DE, DK, DM, DZ, EC, EE, EG, ES, FI, GB, GD, GE, GH, GM, HN, HR, HU, ID, IL, IN, IS, JP, KE, KG, KM, KN, KP, KR, KZ, LA, LC, LK, LR, LS, LT, LU, LV, LY, MA, MD, MG, MK, MN, MW, MX, MZ, NA, NG, NI, NO, NZ, OM, PG, PH, PL, PT, RO, RS, RU, SC, SD, SE, SG, SK, SL, SM, SY, TJ, TM, TN, TR, TT, TZ, UA, UG, US, UZ, VC, VN, ZA, ZM, ZW.

(84) **Designated States (unless otherwise indicated, for every kind of regional protection available):** ARIPO (BW, GH, GM, KE, LS, MW, MZ, NA, SD, SL, SZ, TZ, UG, ZM,

[Continued on next page]

(54) **Title:** AXIALLY NESTED SLIDE AND LOCK EXPANDABLE DEVICE

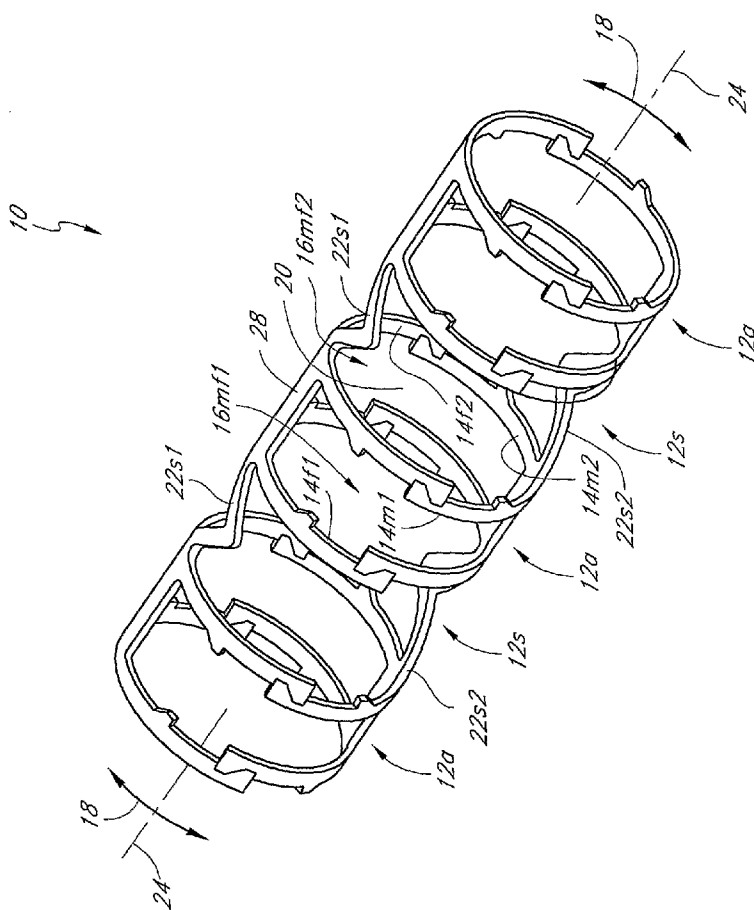

(57) **Abstract:** The invention relates generally to expandable medical implants for maintaining support of a body lumen and, in particular, to an axially nested, diametrically expandable, slide and lock vascular device for enlarging an occluded portion of a vessel. The axially nested vascular device desirably achieves both competitive crossing profiles while maintaining other key features, such as, for example, radial strength and luminal patency. The collapsed profile can also be made very thin without compromising radial strength. Thus, the vascular device can advantageously be deployed in small and difficult to reach areas or vessels. The axial nesting substantially eliminates radial overlap between mating structural elements thereby desirably allowing for a low, uniform profile.

WO 2007/016409 A1



ZW), Eurasian (AM, AZ, BY, KG, KZ, MD, RU, TJ, TM), European (AT, BE, BG, CH, CY, CZ, DE, DK, EE, ES, FI, FR, GB, GR, HU, IE, IS, IT, LT, LU, LV, MC, NL, PL, PT, RO, SE, SI, SK, TR), OAPI (BF, BJ, CF, CG, CI, CM, GA, GN, GQ, GW, ML, MR, NE, SN, TD, TG).

Declaration under Rule 4.17:

— *of inventorship (Rule 4.17(iv))*

Published:

— *with international search report*
— *before the expiration of the time limit for amending the claims and to be republished in the event of receipt of amendments*

For two-letter codes and other abbreviations, refer to the "Guidance Notes on Codes and Abbreviations" appearing at the beginning of each regular issue of the PCT Gazette.

AXIALLY NESTED SLIDE AND LOCK EXPANDABLE DEVICE

Background of the Invention

Field of the Invention

[0001] The invention relates generally to expandable medical implants for maintaining support of a body lumen. More particularly, the invention relates to a predominantly axially nested, diametrically expandable, slide and lock device for enlarging a portion of a body lumen.

Description of the Related Art

[0002] Stents or expandable stent grafts are implanted in a variety of body lumens in an effort to maintain their patency. The body lumens no matter how large or small may be vascular and nonvascular. These devices are typically intraluminally implanted by use of a catheter, which is inserted at an easily accessible location and then advanced to the deployment site. The stent is initially in a radially compressed or collapsed state to enable it to be maneuvered through the lumen. Once in position, the stent is deployed which, depending on its configuration, may be achieved either automatically or manually, by for example, the inflation of a balloon about which the stent is carried on the catheter.

[0003] An important and frequent use of stents is the treatment of blood vessels in situations where part of the vessel wall or stenotic plaque blocks or occludes fluid flow in the vessel. Often, a balloon catheter is utilized in a percutaneous transluminal coronary angioplasty procedure to enlarge the occluded portion of the vessel. However, the dilation of the occlusion can cause fissuring of atherosclerotic plaque and damage to the endothelium and underlying smooth muscle cell layer, potentially leading to immediate problems from flap formation or perforations in the vessel wall, as well as long-term problems with restenosis of the dilated vessel. Implantation of stents can provide support for such problems and prevent re-closure of the vessel or provide patch repair for a perforated vessel. Further, the stent may overcome the tendency of diseased vessel walls to collapse, thereby maintaining a more normal flow of blood through that vessel. Stents are also now being used in other clinical conditions such as in patients with unstable vulnerable plaque lesions.

[0004] As stents are normally employed to hold open an otherwise blocked, constricted or occluded lumen, a stent must exhibit sufficient radial or hoop strength in its expanded state to effectively counter the anticipated forces. It is, however, simultaneously necessary for the stent to be as compact as possible in its collapsed state in order to facilitate its advancement through the lumen. As a result, it is advantageous for a stent to have as large an expansion ratio as possible.

[0005] An additional consideration is the longitudinal flexibility of the device. Such characteristic is important not only in maneuvering the stent into position, which may require the traversal of substantial convolutions of the vasculature, but also to better conform to any curvature of the vasculature at the deployment site. At the same time it is, however, necessary for the stent to nonetheless exhibit sufficient radial strength to provide the necessary support for the lumen walls upon deployment.

[0006] Another problem inherent in many prior art stent configurations is the longitudinal contraction that such structures typically undergo as they are radially expanded. This not only reduces the effective length of the stent in its deployed state but may cause abrasion trauma to be inflicted on the vessel walls during expansion.

[0007] A number of very different approaches have been previously devised in an effort to address these various requirements. A popular approach calls for the stent to be constructed wholly of wire. The wire is bent, woven and/or coiled to define a generally cylindrical structure in a configuration that has the ability to undergo radial expansion. The use of wire has a number of disadvantages associated therewith including for example, its substantially constant cross-section which may cause greater or lesser than an ideal amount of material to be concentrated at certain locations along the stent. Additionally, wire has limitations with respect to the shapes it can be formed into thus limiting the expansion ratio, coverage area, flexibility and strength that can ultimately be attained therewith.

[0008] As an alternative to wire-based structures, stents have been constructed from tube stock. By selectively removing material from such tubular starting material, a desired degree of flexibility and expandability can be imparted to the structure. Etching techniques as well as laser-cutting processes are utilized to remove material from the tube. Laser cutting provides for a high degree of precision and accuracy with which very well

defined patterns of material can be removed from the tube to conversely leave very precisely and accurately defined patterns of material in tact. The performance of such stent is very much a function of the pattern of material which remains (i.e., design) and material thickness. The selection of a particular pattern has a profound effect on the coverage area, expansion ratio and strength of the resulting stent as well as its longitudinal flexibility and longitudinal dimensional stability during expansion.

[0009] While the tube-based stents offer many advantages over the wire-based designs, it is nonetheless desirable to improve upon such designs in an effort to further enhance longitudinal flexibility and longitudinal dimensional stability during radial expansion without sacrificing radial hoop strength.

[0010] One stent design described by Fordenbacher, see e.g., U.S. Patent Nos. 5,549,662 and 5,733,328, employs a plurality of elongated parallel stent components, each having a longitudinal backbone that spans the entire axial length of the stent and a plurality of opposing circumferential elements or fingers extending therefrom. The circumferential elements from one stent component weave into paired slots in the longitudinal backbone of an adjacent stent component. This weave-like interlocking configuration, wherein a circumferential element passes through the first slot in a pair and then weaves back through the second slot in the pair, is essential to Fordenbacher's goal of permitting radial expansion without material deformation. In addition, sufficient members of circumferential elements in the Fordenbacher stent may provide adequate scaffolding. Unfortunately, the circumferential elements have free ends, protruding from the paired slots. Moreover, the circumferential elements weaving through the paired slots also necessarily stand off from the lumen wall. Both the free ends and the stand off may pose significant risks of thrombosis and/or restenosis. Moreover, this stent design would tend to be rather inflexible as a result of the plurality of longitudinal backbones.

[0011] Some stents employ "jelly roll" designs, wherein a sheet is rolled upon itself with a high degree of overlap in the collapsed state and a decreasing overlap as the stent unrolls to an expanded state. Examples of such designs are described in U.S. Patent Nos. 5,421,955 to Lau, 5,441,515 and 5,618,299 to Khosravi, and 5,443,500 to Sigwart. The disadvantage of these designs is that they tend to exhibit very poor longitudinal flexibility. In

a modified design that exhibits improved longitudinal flexibility, multiple short rolls are coupled longitudinally. See e.g., U.S. Patent Nos. 5,649,977 to Campbell and 5,643,314 and 5,735,872 to Carpenter. However, these coupled rolls lack vessel support between adjacent rolls. Furthermore, these designs exhibit extensive overlapping of stent elements in multiple layers, which makes the delivery profile rather thick.

[0012] Various types of stents, including those referenced above, are often described based on their means for expansion. For additional information, a variety of stents types are described by Balcon et al., "Recommendations on Stent Manufacture, Implantation and Utilization," *European Heart Journal* (1997), vol. 18, pages 1536-1547, and Phillips, et al., "The Stenter's Notebook," Physician's Press (1998), Birmingham, Michigan.

[0013] Balloon expandable stents are manufactured in the collapsed condition and are expanded to a desired diameter with a balloon. The expandable stent structure may be held in the expanded condition by mechanical deformation of the stent as taught in, for example, U.S. Patent No. 4,733,665 to Palmaz. Alternatively, balloon expandable stents may be held in the expanded condition by engagement of the stent walls with respect to one another as disclosed in, for example, U.S. Patent Nos. 4,740,207 to Kremer, 4,877,030 to Beck et al., and 5,007,926 to Derbyshire. Further still, the stent may be held in the expanded condition by one-way engagement of the stent walls together with tissue growth into the stent, as disclosed in U.S. Patent No. 5,059,211 to Stack et al.

[0014] Although balloon expandable stents are the first stent type to be widely used in clinical applications, it is well recognized that balloon expandable stents have a variety of shortcomings which may limit their effectiveness in many important applications. For example, balloon expandable stents often exhibit substantial recoil (i.e., a reduction in diameter) immediately following deflation of the inflatable balloon. Accordingly, it may be necessary to over-inflate the balloon during deployment of the stent to compensate for the subsequent recoil. This is disadvantageous because it has been found that over-inflation may damage the blood vessel. Furthermore, a deployed balloon expandable stent may exhibit chronic recoil over time, thereby reducing the patency of the lumen. Still further, balloon expandable stents often exhibit foreshortening (i.e., a reduction in length) during expansion, thereby creating undesirable stresses along the vessel wall and making stent placement less

precise. Still further, many balloon expandable stents, such as the original Palmaz-Schatz stent and later variations, are configured with an expandable mesh having relatively jagged terminal prongs, which increases the risk of injury to the vessel, thrombosis and/or restenosis.

[0015] Self-expanding stents are manufactured with a diameter approximately equal to, or larger than, the vessel diameter and are collapsed and constrained at a smaller diameter for delivery to the treatment site. Self-expanding stents are commonly placed within a sheath or sleeve to constrain the stent in the collapsed condition during delivery. After the treatment site is reached, the constraint mechanism is removed and the stent self-expands to the expanded condition. Most commonly, self-expanding stents are made of Nitinol or other shape memory alloy. One of the first self-expanding stents used clinically is the braided "WallStent," as described in U.S. Patent No. 4,954,126 to Wallsten. Another example of a self-expanding stent is disclosed in U.S. Patent No. 5,192,307 to Wall wherein a stent-like prosthesis is formed of plastic or sheet metal that is expandable or contractible for placement.

[0016] Heat expandable stents are similar in nature to self-expanding stents. However, this type of stent utilizes the application of heat to produce expansion of the stent structure. Stents of this type may be formed of a shape memory alloy, such as Nitinol or other materials, such as polymers, that must go through a thermal transition to achieve a dimensional change. Heat expandable stents are often delivered to the affected area on a catheter capable of receiving a heated fluid. Heated saline or other fluid may be passed through the portion of the catheter on which the stent is located, thereby transferring heat to the stent and causing the stent to expand. However, heat expandable stents have not gained widespread popularity due to the complexity of the devices, unreliable expansion properties and difficulties in maintaining the stent in its expanded state. Still further, it has been found that the application of heat during stent deployment may damage the blood vessel.

[0017] In summary, although a wide variety of stents have been proposed over the years for maintaining the patency of a body lumen, none of the existing schemes has been capable of overcoming most or all of the above described shortcomings. As a result, clinicians are forced to weigh advantages against shortcomings when selecting a stent type to use in a particular application. Accordingly, there remains a need for an improved stent: one

that is compact and flexible enough when collapsed to permit uncomplicated delivery to the affected area; one that is sufficiently flexible upon deployment to conform to the shape of the affected body lumen; one that expands uniformly to a desired diameter, without change in length; one that maintains the expanded size, without significant recoil; and one that has sufficient scaffolding to provide a clear through-lumen.

Summary of the Invention

[0018] For purposes of summarizing the invention, certain aspects, advantages and novel features of the invention have been described herein above. Of course, it is to be understood that not necessarily all such advantages may be achieved in accordance with any particular embodiment of the invention. Thus, the invention may be embodied or carried out in a manner that achieves or optimizes one advantage or group of advantages as taught or suggested herein without necessarily achieving other advantages as may be taught or suggested herein.

[0019] Some embodiments provide a diametrically expanding, slide and lock vascular device, prosthesis or stent comprising elements or members that do not substantially overlap each other in the radial direction, i.e., do not lay (nest) upon each other in the deployed state. In the nested (non-expanded, undeployed, predilated) position, the radial thickness of two overlapping elements is less than about two times the nominal material thickness. Overlap in the non-deployed state is generally acceptable as long a suitable crossing profile is achieved while in the deployed state there is desirably substantially no, minimal or reduced overlap.

[0020] During manufacture and assembly of the axially nested embodiments, the device structural elements are substantially majorly or primarily positioned side by side (axially) in the predilated or non-expanded state to substantially reduce or minimize the device crossing profile and bulk in both the undeployed (non-expanded, predilated) and deployed (expanded, dilated) states. Advantageously, by substantially reducing or eliminating the excess bulk typically encountered with a radially nesting device design, embodiments of the invention can be used to achieve competitive devices and crossing profiles with a wide variety of materials at a wide variety of thicknesses, thereby desirably allowing for optimum device design and performance.

[0021] Many conventional slide and lock vascular devices comprise elements that overlap each other in the radial direction, i.e., lay upon each other. This feature can limit that thickness of material that can be employed as well as the number of elements that can be employed. As the thickness or element number increases, competitive features of the device may be compromised, such as crossing profile. To provide acceptable crossing profiles, the

thicknesses and the number of elements employed in these radially nesting devices is often reduced, which can have an impact on such features as reliability and device radial strength.

[0022] Embodiments of the invention provide an axially nested vascular device to achieve both competitive crossing profiles while maintaining other key features, such as, for example, radial strength and luminal patency. Advantageously, an axially nested device design allows for use of thicker materials to maintain radial strength, as needed or desired.

[0023] Embodiments of the invention can utilize a number of features to create slide and lock mechanisms that allow for controlled and predictable device expansion. For example, deflectable and non-deflectable elements and members can be employed to achieve desired deployment and lock out performance. The skilled artisan will appreciate that a variety of mechanisms, features and/or geometries can readily be included to achieve the desired deployment and lock out performance. For example, mechanisms can be employed that incorporate the bulk of the structural element, or smaller localized sub-elements can be employed.

[0024] Some embodiments provide a slide-and-lock stent that comprises a tubular member that is expandable from a collapsed state to an expanded state. The tubular member comprises at least one slide-and-lock section, comprising separate first and second axially nested, slidably coupled structural elements, at least one of which comprises a deflectable structure configured to deflect during expansion from the collapsed state to the expanded state, thereby resisting recoil, and wherein no portion of either structural elements weaves through paired slots in the other structural element.

[0025] In preferred variations, the deflectable structure is configured to deflect axially. Alternatively, the deflectable structure is configured to deflect radially.

[0026] Some embodiments provide a slide-and-lock stent that comprises a tubular member. The tubular member is expandable from a collapsed diameter to an expanded diameter. The tubular member comprises a first circumferential slide-and-lock section and a second circumferential slide-and-lock section. The slide-and-lock sections are longitudinally arranged and linked. Each of the slide-and-lock sections comprises a first axial element and a second axial element. The corresponding axial elements of each slide-and-lock section are spatially offset and connected by an interlocking articulating mechanism. Each of the first

axial elements comprises a first rib with least one axially outwardly extending tooth and each of the second axial elements comprises a second rib with at least one axially inwardly extending tooth. Corresponding outwardly and inwardly extending teeth engage one another during expansion and are configured to permit one-way sliding between the corresponding first and second axial elements such that at least one of the corresponding first and second ribs is axially and temporarily deflected during expansion from the collapsed diameter to the expanded diameter.

[0027] Some embodiments provide a slide-and-lock stent that comprises a tubular member. The tubular member is expandable from a first diameter to a second diameter. The tubular member comprises a first circumferential section and a second circumferential section. The circumferential sections are longitudinally arranged. A linkage section connects the circumferential sections and is configured to provide flexibility. Each of the circumferential sections comprises a first slide-and-lock element and a second slide-and-lock element. The corresponding slide-and-lock elements of each circumferential section are radially connected by a slidable articulating mechanism. Each of the first slide-and-lock elements comprises at least one tooth and each of the second slide-and-lock elements comprises at least one radially extending tooth. During expansion the teeth of the first slide-and-lock elements engage corresponding radially extending teeth of the second slide and lock sections. The teeth are configured to permit one-way sliding between the corresponding first and second slide-and-lock elements such that at least a portion of the corresponding first and second slide-and-lock elements is radially deflected during expansion from the first diameter to the second diameter.

[0028] Some embodiments provide a slide-and-lock stent that comprises a tubular member. The tubular member is expandable from a collapsed state to an expanded state and comprises a lumen. The tubular member comprises at least one slide-and-lock section. The slide-and-lock section comprises at least one first structural element and at least one second structural element that are radially interlocked with an articulating mechanism such as to provide circumferential relative motion between the first structural element and the second structural element. The articulating mechanism is configured to permit one-way sliding between the first structural element and the second structural element such that at least a

portion of the first structural element and/or at least a portion of the second structural element is elastically deflected during expansion from the collapsed state to the expanded state. Advantageously, the radial interlocking between the structural elements substantially eliminates radial overlap and allows for a substantially clear through-lumen such that substantially no structure protrudes into the lumen in either the collapsed or the expanded state.

[0029] In embodiments of the invention, structural elements can be linked together and interlocking elements captured through a wide variety of techniques. For example, channels can be created or added that allow the elements to slide within, between or therethrough. Other examples include, but are not limited to, capture straps, overhanging elements, covers, tongue-groove configurations and other suitable geometries, that can be employed or created through a wide variety of techniques to provide for linkage and capture of elements.

[0030] Embodiments of the invention provide an improved stent: one that desirably is small enough and flexible enough when collapsed to permit uncomplicated delivery to the affected area; one that is sufficiently flexible upon deployment to conform to the shape of the affected body lumen; one that expands uniformly to a desired diameter, without change in length; one that maintains the expanded size, without significant recoil; one that has sufficient scaffolding to provide a clear through-lumen; one that supports endothelialization or covering of the stent with vessel lining, which in turn minimizes the risk of thrombosis; and one that has a greater capacity to deliver therapeutic agents to minimize injury, treat restenosis and other vascular diseases.

[0031] Stents in accordance with embodiments of the invention can be fabricated or created using a wide variety of manufacturing methods, techniques and procedures. These include, but are not limited to, lasing, laser processing, milling, stamping, forming, casting, molding, laminating, bonding, welding, adhesively fixing, and the like, among others.

[0032] In some embodiments, stent features and mechanisms are created in a generally two dimensional geometry and further processed, for example by utilizing, but not limited to, bonding, lamination and the like, into three dimensional designs and features. In other embodiments, stent features and mechanisms are directly created into three dimensional

shapes, for example by utilizing, but not limited to, processes such as injection molding and the like.

[0033] In preferred variations to the above-described stents, the stent further comprises a material selected from the group consisting of metal and polymer. Preferably, the polymer comprises a bioresorbable polymer. More preferably, the polymer comprises a radiopaque, bioresorbable polymer. In one aspect, the polymer forms a coating on at least a portion of the stent. The polymer coating may further comprise a biocompatible, bioresorbable polymer adapted to promote a selected biological response.

[0034] A method for re-treatment of a body lumen is disclosed in accordance with another embodiment of the present invention. The method comprises the steps of: deploying to a region of the body lumen any of the above described stents, wherein the stent is made from a bioresorbable polymer, and resides at the region for a period of time; and administering to the region, after the period of time, a second treatment, such as for example, treatments selected from the group consisting of a second stent of any kind, angioplasty, arthrectomy, surgical bypass, radiation, ablation, local drug infusion, etc., or any subsequent intervention or treatment.

[0035] In preferred variations to the above-described stents, the stent further comprises a therapeutic agent.

[0036] In preferred variations to the above-described stents, the stent further comprises a layered material. Preferably, the layered material comprises a bioresorbable polymer.

[0037] One key design aspect of embodiments of a slide and lock vascular device is its deployment ratio, that is, the ratio of final maximum diameter to initial compacted diameter. Depending upon the particular design being pursued or the application being addressed, the deployment ratio may vary. Advantageously, the stent of embodiments of the invention allows the number of elements to be increased or decreased, that is, varied, as needed or desired, to achieve optimization of the deployment ratio as well as device performance, crossing profile, flexibility, among others. This desirably adds to the device versatility and utility.

[0038] In preferred variations to the above-described stents, a cross-sectional geometry of at least a portion of the stent is tapered so as to produce generally desirable blood flow characteristics when the stent is placed in a blood vessel lumen.

[0039] In preferred variations to the above-described stents, the stent further comprises a retractable sheath sized for enclosing the tubular member during delivery to a treatment site.

[0040] In preferred variations to the above-described stents, the stent further comprises a solid wall region. The solid wall region may further comprise an opening.

[0041] In preferred variations to the above-described stents, the stent further comprises a polymeric sheath.

[0042] A system for treating a site within a vessel is also disclosed. The system comprises a catheter having a deployment means, and any of the above-described stents, wherein the catheter is adapted to deliver the stent to the site and the deployment means is adapted to deploy the stent. In preferred variations, the catheter is selected from the group consisting of over-the-wire catheters, coaxial rapid-exchange catheters, and multi-exchange delivery catheters.

[0043] All of these embodiments are intended to be within the scope of the invention herein disclosed. These and other embodiments of the invention will become readily apparent to those skilled in the art from the following detailed description of the preferred embodiments having reference to the attached figures, the invention not being limited to any particular preferred embodiment(s) disclosed.

Brief Description of the Drawings

[0044] Having thus summarized the general nature of the invention and some of its features and advantages, certain preferred embodiments and modifications thereof will become apparent to those skilled in the art from the detailed description herein having reference to the figures that follow, of which:

[0045] **FIG. 1A** is a simplified schematic end view of an axially nested slide and lock stent illustrating features and advantages in accordance with an embodiment of the invention.

[0046] **FIG. 1B** is a simplified schematic side view of an axially nested slide and lock stent illustrating features and advantages in accordance with another embodiment of the invention.

[0047] **FIG. 2** is a simplified perspective view of an axially nested slide and lock stent in an expanded state illustrating features and advantages in accordance with an embodiment of the invention.

[0048] **FIG. 3** is a simplified partially exploded perspective view of an undeployed section of the stent of **FIG. 2** illustrating features and advantages in accordance with an embodiment of the invention.

[0049] **FIG. 4** is a simplified partially exploded perspective view of a deployed section of the stent of **FIG. 2** illustrating features and advantages in accordance with an embodiment of the invention.

[0050] **FIG. 5** is a simplified planar perspective view of sections of the stent of **FIG. 2** illustrating features and advantages in accordance with an embodiment of the invention.

[0051] **FIG. 6** is a simplified planar perspective partial view of a section of the stent of **FIG. 2** with a capture mechanism illustrating features and advantages in accordance with an embodiment of the invention.

[0052] **FIG. 7** is a simplified planar perspective partial view of a section of the stent of **FIG. 2** with a capture mechanism illustrating features and advantages in accordance with another embodiment of the invention.

[0053] FIG. 8 is a simplified planar enlarged perspective view of the capture mechanism of FIG. 7.

[0054] FIG. 9 is a simplified planar perspective view of a stent articulation geometry illustrating features and advantages in accordance with an embodiment of the invention.

[0055] FIG. 10 is a simplified planar perspective view of a stent articulation geometry illustrating features and advantages in accordance with another embodiment of the invention.

[0056] FIG. 11 is a simplified planar perspective partial view of an axially nested slide and lock stent section with an axially deflecting arm mechanism illustrating features and advantages in accordance with an embodiment of the invention.

[0057] FIG. 12 is a simplified planar perspective partial view of at least one axially nested slide and lock stent section with an axially deflecting arm mechanism illustrating features and advantages in accordance with another embodiment of the invention.

[0058] FIGS. 13A and 13B are simplified planar perspective partial views of axially nested slide and lock stent sections with an axially deflecting arm mechanism illustrating features and advantages in accordance with yet another embodiment of the invention.

[0059] FIGS. 14A and 14B are simplified planar perspective partial views of axially nested slide and lock stent sections with an axially deflecting mechanism illustrating features and advantages in accordance with still another embodiment of the invention.

[0060] FIG. 15 is a simplified planar perspective partial view of an axially nested slide and lock stent section with a radially deflecting arm mechanism illustrating features and advantages in accordance with an embodiment of the invention.

[0061] FIG. 16 is a simplified planar perspective view of an axially nested slide and lock stent section with a radially deflecting arm mechanism illustrating features and advantages in accordance with another embodiment of the invention.

[0062] FIG. 17 is simplified planar perspective enlarged partial view of the stent section of FIG. 16 illustrating features and advantages in accordance with an embodiment of the invention.

[0063] **FIG. 18** is a simplified planar perspective enlarged partial view of the stent section of **FIG. 16** showing radial rib deflection and illustrating features and advantages in accordance with an embodiment of the invention.

[0064] **FIG. 19** is a simplified planar perspective partial view of an axially nested slide and lock stent section with an axially deflecting mechanism in a collapsed state illustrating features and advantages in accordance with an embodiment of the invention.

[0065] **FIG. 20** is a simplified planar perspective partial view of the axially nested slide and lock stent section of **FIG. 19** in an expanded state illustrating features and advantages in accordance with an embodiment of the invention.

[0066] **FIG. 21** is a conceptual simplified perspective view of an axially nested slide and lock stent in a deployed state illustrating features and advantages in accordance with an embodiment of the invention.

[0067] **FIG. 22** is a conceptual simplified perspective view of an axially nested slide and lock stent in an undeployed state illustrating features and advantages in accordance with an embodiment of the invention.

[0068] **FIGS. 23A and 23B** are conceptual simplified perspective views of an axially nested slide and lock stent in an undeployed state illustrating features and advantages in accordance with an embodiment of the invention.

[0069] **FIG. 24** is a simplified end view of the stent of **FIG. 23B** illustrating features and advantages in accordance with an embodiment of the invention.

[0070] **FIG. 25** is a conceptual simplified perspective view of the stent of **FIG. 22** in a deployed state illustrating features and advantages in accordance with an embodiment of the invention.

[0071] **FIGS. 26A and 26B** are conceptual simplified perspective views of the respective stents of **FIGS. 23A and 23B** in a deployed state illustrating features and advantages in accordance with an embodiment of the invention.

[0072] **FIG. 27** is a simplified end view of the stent of **FIG. 26B** illustrating features and advantages in accordance with an embodiment of the invention.

[0073] **FIG. 28** is a simplified planar perspective view of an axially nested slide and lock stent in a partially expanded state illustrating features and advantages in accordance with an embodiment of the invention.

[0074] **FIG. 29** is a simplified planar perspective view of an axially nested slide and lock stent in an almost fully expanded state illustrating features and advantages in accordance with an embodiment of the invention.

[0075] **FIG. 30** is a simplified planar view of an axially nested slide and lock stent in a collapsed state illustrating features and advantages in accordance with an embodiment of the invention.

[0076] **FIG. 31** is a simplified planar partial view of an axially nested slide and lock stent section in a collapsed state illustrating features and advantages in accordance with an embodiment of the invention.

[0077] **FIG. 32** is a simplified planar view of an axially nested slide and lock stent in a fully expanded state illustrating features and advantages in accordance with an embodiment of the invention.

[0078] **FIG. 33** is a simplified planar partial view of an axially nested slide and lock stent section a partially expanded state illustrating features and advantages in accordance with an embodiment of the invention.

[0079] **FIG. 34** is a simplified planar view of an axially nested slide and lock stent section in an almost fully expanded state illustrating features and advantages in accordance with an embodiment of the invention.

[0080] **FIG. 35** is a simplified planar partial view of an axially nested slide and lock stent section in an almost fully expanded state illustrating features and advantages in accordance with an embodiment of the invention.

[0081] **FIG. 36** is another simplified planar partial view of an axially nested slide and lock stent section in an almost fully expanded state illustrating features and advantages in accordance with an embodiment of the invention.

[0082] **FIG. 37** is a simplified planar perspective partial view of an axially nested slide and lock stent section in an almost fully expanded state illustrating features and advantages in accordance with an embodiment of the invention.

[0083] FIG. 38 is a simplified planar perspective view of an axially nested slide and lock stent during its manufacture and assembly illustrating features and advantages in accordance with an embodiment of the invention.

[0084] FIG. 39 is a simplified planar view of an axially nested slide and lock stent in a compacted state illustrating features and advantages in accordance with an embodiment of the invention.

[0085] FIG. 40 is a simplified planar view of the stent of FIG. 39 in an expanded state illustrating features and advantages in accordance with an embodiment of the invention.

[0086] FIG. 41 is a simplified planar perspective partial view of the stent of FIG. 39 illustrating features and advantages in accordance with an embodiment of the invention.

[0087] FIG. 42 is a simplified planar perspective enlarged view of structural element of the stent of FIG. 39 illustrating features and advantages in accordance with an embodiment of the invention.

[0088] FIG. 43 is a simplified planar perspective view of an axially nested slide and lock stent in a partially expanded state illustrating features and advantages in accordance with an embodiment of the invention.

[0089] FIG. 44 is a simplified planar perspective view of an axially nested slide and lock stent in an expanded state illustrating features and advantages in accordance with another embodiment of the invention.

[0090] FIG. 45 is a simplified planar enlarged perspective view of a slide and lock articulation mechanism of the stent of FIG. 44 illustrating features and advantages in accordance with another embodiment of the invention.

[0091] FIG. 46 is a simplified planar perspective partial view of the stent of FIG. 43 or FIG. 44 during its manufacture and assembly illustrating features and advantages in accordance with an embodiment of the invention.

[0092] FIG. 47 is a simplified planar perspective view of an axially nested slide and lock stent in a partially expanded state illustrating features and advantages in accordance with an embodiment of the invention.

[0093] FIG. 48 is a simplified planar perspective view of an axially nested slide and lock stent in a partially expanded state illustrating features and advantages in accordance with another embodiment of the invention.

[0094] FIG. 49 is a simplified planar perspective partial view of the stent of FIG. 47 during its manufacture and assembly illustrating features and advantages in accordance with an embodiment of the invention.

[0095] FIG. 50 is a simplified planar perspective partial view of the stent of FIG. 47 during its manufacture and assembly illustrating features and advantages in accordance with another embodiment of the invention.

[0096] FIG. 51 is a conceptual planar perspective view of structural elements of an axially nested slide and lock stent in a partially expanded state illustrating features and advantages in accordance with an embodiment of the invention.

[0097] FIG. 52 is a conceptual planar perspective view of structural elements of an axially nested slide and lock stent in a partially expanded state illustrating features and advantages in accordance with another embodiment of the invention.

[0098] FIG. 53 is a conceptual planar perspective view of structural elements of an axially nested slide and lock stent in a partially expanded state illustrating features and advantages in accordance with yet another embodiment of the invention.

[0099] FIG. 54 is a conceptual planar perspective view of structural elements of an axially nested slide and lock stent in a partially expanded state illustrating features and advantages in accordance with still another embodiment of the invention.

[0100] FIG. 55 is a conceptual planar perspective view of structural elements of an axially nested slide and lock stent in a partially expanded state illustrating features and advantages in accordance with a further embodiment of the invention.

[0101] FIG. 56 is a conceptual planar perspective view of structural elements of an axially nested slide and lock stent in a partially expanded state illustrating features and advantages in accordance with a another further embodiment of the invention.

[0102] FIG. 57 is a simplified planar perspective view of an axially nested slide and lock stent illustrating features and advantages in accordance with an embodiment of the invention.

[0103] FIG. 58 is a simplified planar perspective view of the stent of FIG. 57 in a collapsed state illustrating features and advantages in accordance with an embodiment of the invention.

[0104] FIG. 59 is a simplified planar view of the stent of FIG. 57 in a collapsed state illustrating features and advantages in accordance with an embodiment of the invention.

[0105] FIG. 60 is a simplified planar view of the stent of FIG. 57 in an expanded state illustrating features and advantages in accordance with an embodiment of the invention.

[0106] FIG. 61 is a simplified planar perspective top view of a slide and lock articulation mechanism of the stent of FIG. 57 illustrating features and advantages in accordance with an embodiment of the invention.

[0107] FIG. 62 is a simplified planar perspective bottom view of a slide and lock articulation mechanism of the stent of FIG. 57 illustrating features and advantages in accordance with an embodiment of the invention.

[0108] FIG. 63 is a simplified planar perspective view of an axially nested slide and lock stent in an expanded state illustrating features and advantages in accordance with another embodiment of the invention.

Detailed Description of the Preferred Embodiments

[0109] While the description sets forth various embodiment specific details, it will be appreciated that the description is illustrative only and should not be construed in any way as limiting the invention. Furthermore, various applications of the invention, and modifications thereto, which may occur to those who are skilled in the art, are also encompassed by the general concepts described herein.

[0110] The term "stent" is used herein to designate embodiments for placement in (1) vascular body lumens (i.e., arteries and/or veins) such as coronary vessels, neurovascular vessels and peripheral vessels for instance renal, iliac, femoral, popliteal, subclavian and carotid; and in (2) nonvascular body lumens such as those treated currently i.e., digestive lumens (e.g., gastrointestinal, duodenum and esophagus, biliary ducts), respiratory lumens (e.g., tracheal and bronchial), and urinary lumens (e.g., urethra); (3) additionally such embodiments may be useful in lumens of other body systems such as the reproductive, endocrine, hematopoietic and/or the integumentary, musculoskeletal/orthopedic and nervous systems (including auditory and ophthalmic applications); and, (4) finally, stent embodiments may be useful for expanding an obstructed lumen and for inducing an obstruction (e.g., as in the case of aneurysms).

[0111] In the following description of the present invention, the term "stent" may be used interchangeably with the term "prosthesis" and should be interpreted broadly to include a wide variety of devices configured for supporting a segment of a body passageway. Furthermore, it should be understood that the term "body passageway" encompasses any lumen or duct within a body, such as those described herein.

[0112] Still further, it should be understood that the term "shape-memory material" is a broad term that includes a variety of known shape memory alloys, such as nickel-titanium alloys, as well as any other materials that return to a previously defined shape after undergoing substantial plastic deformation.

[0113] In one preferred embodiment, the assembled stent generally comprises a tubular member having a length in the longitudinal axis and a diameter in the circumferential axis sized for insertion into the body lumen. The tubular member is preferably formed with a

"clear through-lumen," which is defined as having little or no structure protruding into the lumen in either the collapsed or expanded condition.

[0114] In many of the embodiments illustrated and described herein, the intraluminal stent is preferably provided with "slide-and-lock elements" generally referred to herein as "axial elements." The axial elements are slidably interconnected with circumferentially adjacent axial elements in a manner wherein the stent exhibits mono-directional axial expansion from an axially collapsed state to an axially expanded state, e.g., during deployment. The axial elements are preferably configured to provide a ratcheting effect such that the stent is maintained (i.e., "locked-out") in the expanded diameter after deployment within the body passage. More particularly, the structures (e.g., axial elements) may flex or bend; however, unlike conventional balloon expandable stents, no substantial plastic deformation of the elements are required during expansion of the stent from a collapsed diameter to an expanded diameter. Elements of this type are generally referred to herein as "non-deforming elements." Accordingly, the term "non-deforming element" is intended to generally describe a structure that substantially maintains its original dimensions (i.e., length and width) during deployment of the stent. Each axial element is preferably formed as a flat sheet that is cut or otherwise shaped to provide a slide-and-lock mechanism.

[0115] The phrase "weaves through paired slots" has the meaning described in U.S. Patent Nos. 5,549,662 and 5,733,328. As used herein, this phrase describes a particular slidable coupling or articulation between stent components, wherein a portion of one stent component passes through one of a pair of slots in another stent component, and then passes back through the second of the pair of slots, creating a weave-like interlocking configuration. Preferred embodiments of the present invention employ slidable couplings or articulations between stent components that avoid weave-like configurations, such that in these preferred embodiments, no portion of a stent component weaves through paired slots in another stent component.

[0116] The term "radial strength," as used herein, describes the external pressure that a stent is able to withstand without incurring clinically significant damage. Due to their high radial strength, balloon expandable stents are commonly used in the coronary arteries to ensure patency of the vessel. During deployment in a body lumen, the inflation of the

balloon can be regulated for expanding the stent to a particular desired diameter. Accordingly, balloon expandable stents may be used in applications wherein precise placement and sizing are important. Balloon expandable stents may be used for direct stenting applications, where there is no pre-dilation of the vessel before stent deployment, or in prosthetic applications, following a pre-dilation procedure (e.g., balloon angioplasty). During direct stenting, the expansion of the inflatable balloon dilates the vessel while also expanding the stent.

[0117] In another preferred embodiment, the stent further comprises a tubular member formed from a biocompatible and preferably, bioresorbable polymer, such as those disclosed in co-pending US Application No. 10/952,202; incorporated herein in its entirety by reference. It is also understood that the various polymer formulae employed may include homopolymers and heteropolymers, which includes stereoisomers. Homopolymer is used herein to designate a polymer comprised of all the same type of monomers. Heteropolymer is used herein to designate a polymer comprised of two or more different types of monomer which is also called a co-polymer. A heteropolymer or co-polymer may be of a kind known as block, random and alternating. Further with respect to the presentation of the various polymer formulae, products according to embodiments of the present invention may be comprised of a homopolymer, heteropolymer and/or a blend of such polymers.

[0118] The term "bioresorbable" is used herein to designate polymers that undergo biodegradation (through the action of water and/or enzymes to be chemically degraded) and at least some of the degradation products are eliminated and/or absorbed by the body. The term "radiopaque" is used herein to designate an object or material comprising the object visible by in vivo analysis techniques for imaging such as, but not limited to, methods such as x-ray radiography, fluoroscopy, other forms of radiation, MRI, electromagnetic energy, structural imaging (such as computed or computerized tomography), and functional imaging (such as ultrasonography). The term, "inherently radiopaque", is used herein to designate polymer that is intrinsically radiopaque due to the covalent bonding of halogen species to the polymer. Accordingly, the term does encompass a polymer which is simply blended with a halogenated species or other radiopacifying agents such as metals and their complexes.

[0119] In another preferred variation, the stent further comprises an amount of a therapeutic agent (for example, a pharmaceutical agent and/or a biologic agent) sufficient to exert a selected therapeutic effect. The term "pharmaceutical agent", as used herein, encompasses a substance intended for mitigation, treatment, or prevention of disease that stimulates a specific physiologic (metabolic) response. The term "biological agent", as used herein, encompasses any substance that possesses structural and/or functional activity in a biological system, including without limitation, organ, tissue or cell based derivatives, cells, viruses, vectors, nucleic acids (animal, plant, microbial, and viral) that are natural and recombinant and synthetic in origin and of any sequence and size, antibodies, polynucleotides, oligonucleotides, cDNA's, oncogenes, proteins, peptides, amino acids, lipoproteins, glycoproteins, lipids, carbohydrates, polysaccharides, lipids, liposomes, or other cellular components or organelles for instance receptors and ligands. Further the term "biological agent", as used herein, includes virus, serum, toxin, antitoxin, vaccine, blood, blood component or derivative, allergenic product, or analogous product, or arsphenamine or its derivatives (or any trivalent organic arsenic compound) applicable to the prevention, treatment, or cure of diseases or injuries of man (per Section 351(a) of the Public Health Service Act (42 U.S.C. 262(a)). Further the term "biological agent" may include 1) "biomolecule", as used herein, encompassing a biologically active peptide, protein, carbohydrate, vitamin, lipid, or nucleic acid produced by and purified from naturally occurring or recombinant organisms, tissues or cell lines or synthetic analogs of such molecules, including antibodies, growth factors, interleukins and interferons; 2) "genetic material" as used herein, encompassing nucleic acid (either deoxyribonucleic acid (DNA) or ribonucleic acid (RNA), genetic element, gene, factor, allele, operon, structural gene, regulator gene, operator gene, gene complement, genome, genetic code, codon, anticodon, messenger RNA (mRNA), transfer RNA (tRNA), ribosomal extrachromosomal genetic element, plasmagene, plasmid, transposon, gene mutation, gene sequence, exon, intron, and, 3) "processed biologics", as used herein, such as cells, tissues or organs that have undergone manipulation. The therapeutic agent may also include vitamin or mineral substances or other natural elements.

[0120] In some embodiments, the design features of the axial elements can be varied to customize the functional features of strength, compliance, radius of curvature at deployment and expansion ratio. In some embodiments, the stent comprises a resorbable material and vanishes when its job is done. In some embodiments, the stent serves as a therapeutic delivery platform.

[0121] The stent preferably comprises at least one longitudinal module, which consists of a series of axial elements, including one or more slide-and-lock axial elements and optionally one or more passive axial elements, linked in the longitudinal axis by flexible coupling portions. Preferably, the axial elements from two or more similar longitudinal modules are slidably connected to circumferentially adjacent axial elements. Of course, single module (or jellyroll-type) embodiments are also encompassed within the scope of the present disclosure. Each module is preferably a discrete, unitary structure that does not stretch or otherwise exhibit any substantial permanent deformation during stent deployment.

[0122] Some embodiments relate to an axially expandable stent used to open, or to expand a targeted area in a body lumen. In some embodiments, the assembled stent comprises a tubular member having a length in the longitudinal axis and a diameter in the circumferential or axial axis, of appropriate size to be inserted into the body lumen. The length and diameter of the tubular member may vary considerably for deployment in different selected target lumens depending on the number and configuration of the structural components, described below. The tubular member is adjustable from at least a first collapsed diameter to at least a second expanded diameter. One or more stops and engaging elements or tabs are incorporated into the structural components of the tubular member whereby recoil (i.e., collapse from an expanded diameter to a more collapsed diameter) is minimized to less than about 5%.

[0123] The tubular member in accordance with some embodiments has a "clear through-lumen," which is defined as having no structural elements protruding into the lumen in either the collapsed or expanded diameters. Further, the tubular member has smooth marginal edges to minimize the trauma of edge effects. The tubular member is preferably thin-walled (wall thickness depending on the selected materials ranging from less than about 0.010 inches for plastic and degradable materials to less than about 0.002 inches for metal

materials) and flexible (e.g., less than about 0.01 Newtons force/millimeter deflection) to facilitate delivery to small vessels and through tortuous vasculature.

[0124] Stents according to aspects of the present invention are preferably formed with walls for providing a low crossing profile and for allowing excellent longitudinal flexibility. In preferred embodiments, the wall thickness is about 0.0001 inches to about 0.0250 inches, and more preferably about 0.0010 to about 0.0100 inches. However, the wall thickness depends, at least in part, on the selected material. For example, the thickness may be less than about 0.0080 inches for plastic and degradable materials and may be less than about 0.0020 inches for metal materials. More particularly, for a 3.00 mm stent application, when a plastic material is used, the thickness is preferably in the range of about 0.0040 inches to about 0.0085 inches. However, a stent having various diameters may employ different thicknesses for biliary and other peripheral vascular applications. The above thickness ranges have been found to provide preferred characteristics through all aspects of the device including assembly and deployment. However, it will be appreciated that the above thickness ranges should not be limiting with respect to the scope of the invention and that the teachings of the present invention may be applied to devices having dimensions not discussed herein.

[0125] Some aspects are also disclosed in co-pending U.S. Patent Application Nos. 11/016,269, 60/601,526, 10/655,338, 10/773,756, 10/897,235; each of which is incorporated herein in its entirety by reference thereto.

[0126] The preferred embodiments of the invention described herein relate generally to expandable medical implants for maintaining support of a body lumen and, in particular, to an axially nested, diametrically expandable, slide and lock vascular device for enlarging an occluded portion of a vessel.

[0127] While the description sets forth various embodiment specific details, it will be appreciated that the description is illustrative only and should not be construed in any way as limiting the invention. Furthermore, various applications of the invention, and modifications thereto, which may occur to those who are skilled in the art, are also encompassed by the general concepts described herein.

[0128] Some embodiments relate to an expandable stent having a plurality of longitudinally arranged sections, segments or frames. The sections have a plurality of axially

nesting sliding and locking elements permitting one-way sliding of the elements from a collapsed diameter to an expanded/deployed diameter, but inhibiting recoil from the expanded diameter. In some embodiments, the stent comprises a polymer and is fabricated by a combination of laminating and laser cutting a plurality of layers. Advantageously, the stent substantially reduces or minimizes overlap between the structural elements and thus desirably reduces the effective wall thickness of the stent. Another advantage is that the stent design elements and interlocks can be varied to customize the functional features of strength, compliance, radius of curvature at deployment and expansion ratio. In some embodiments, the stent comprises a resorbable material and vanishes when its job is done. In some embodiments, the stent serves as a delivery platform for therapeutic agents such as pharmaceutical compounds or biological materials.

[0129] Some embodiments relate to a radially expandable stent used to open, or to expand a targeted area in a body lumen. Some embodiments relate to a radially expandable stent used as a drug delivery platform to treat vascular conditions. In some embodiments, the assembled stent comprises a tubular member having a length in the longitudinal axis and a diameter in the radial axis, of appropriate size to be inserted into the body lumen. The length and diameter of the tubular member may vary considerably for deployment in different selected target lumens depending on the number and configuration of the structural components, described below. The tubular member is adjustable from at least a first collapsed diameter to at least a second expanded diameter. One or more stops, teeth, slots or grooves and engaging elements, tabs, teeth or tongues are incorporated into the structural components of the tubular member whereby recoil (i.e., collapse from an expanded diameter to a more collapsed diameter) is minimized to less than about 5%.

[0130] The tubular member in accordance with some embodiments has a “clear through-lumen,” which is defined as having no structural elements protruding into the lumen in either the collapsed or expanded diameters. Further, the tubular member has smooth marginal edges to minimize the trauma of edge effects. The tubular member is preferably thin-walled (wall thickness depending on the selected materials and intended vessel size to be treated ranging from less than about 0.009 inches for plastic and resorbable materials to less than about 0.0008 inches for metal materials) and flexible to facilitate delivery to small

vessels and through tortuous vasculature. The thin walled design can also minimize blood turbulence and thus risk of thrombosis. The thin profile of the deployed tubular member in accordance with some embodiments also facilitates more rapid endothelialization of the stent.

[0131] In some embodiments, the wall of the tubular member comprises at least one section, which comprises at least one sliding and locking structural element. Preferably, a plurality of sections are connected in the longitudinal axis via linkage elements which couple at least some of the structural elements between adjacent sections. The structural elements are configured within each section so as to generally define the circumference of the tubular member. In some embodiments, each structural element within a section is a discrete, unitary structure. In some embodiments, the tubular member comprises an integral unit including one or more sections with one or more structural elements. In one embodiment, each structural element comprises one or more circumferential ribs bowed in the radial axis to form a fraction of the total circumference of the tubular member.

[0132] At least some of the structural elements have at least one articulating mechanism (e.g., deflecting or non-deflecting) for providing slidable engagement between adjacent circumferentially offset structural elements and/or adjacent axially offset structural elements. In one embodiment, the articulating mechanism includes a tongue and groove configuration. The articulating between structural elements is such that a locking or ratcheting mechanism is formed, whereby the adjacent elements may slide circumferentially in one direction but are substantially prevented from sliding circumferentially in an opposite direction. Accordingly, the tubular member may be radially expanded from a smaller diameter to a larger diameter, but advantageously recoil to a smaller diameter is minimized by the locking mechanism. The amount of recoil can be customized for the application by adjusting the configuration of the articulating locking mechanism. In one embodiment, the recoil is less than about 5%.

[0133] Some features and arrangements of embodiments of stents are disclosed in U.S. Patent Nos. 6,033,436, 6,224,626 and 6,623,521 each issued to Steinke, the disclosures of each one of which are hereby incorporated in their entirety by reference thereto.

Embodiments and Design Features of the Device

[0134] FIG. 1A schematically depicts an end view of one embodiment of a vascular device, prosthesis or stent 10' generally comprising one or more longitudinally arranged sections, segments or frames 12'. Each section 12' includes two or more structural elements 14' that are radially or circumferentially coupled to other structural elements 14' of the same section 12' by one-way slide and lock articulating mechanisms 16'.

[0135] The articulating mechanisms 16' allow one-way expansion of the section 12' from a first collapsed diameter to a second expanded diameter. During expansion, there is circumferential relative motion between the structural elements 14' as generally shown by arrows 18' such that one or both of the structural elements 14' slidably move apart.

[0136] As described in more detail below, even though the structural elements 14' of the same section 12' are radially or circumferentially coupled, the sections 12' and structural elements 14' are designed and configured such that there is minimal or reduced overlapping in the radial or circumferential direction between the structural elements 14' in both the non-expanded and expanded states. Thus, the structural elements 14' are referred to as being axially, longitudinally or non-radially nested.

[0137] FIG. 1B schematically depicts a side view of another embodiment of a vascular device, prosthesis or stent 10'' generally comprising two or more longitudinally arranged sections, segments or frames 12''. Each section 12'' includes one or more structural elements 14''. Structural elements 14'' of adjacent sections 12'' are axially or longitudinally coupled to one another by one-way slide and lock articulating mechanisms 16''.

[0138] The articulating mechanisms 16'' allow one-way expansion of the sections 12'' from a first collapsed diameter to a second expanded diameter. During expansion, there is circumferential relative motion between the structural elements 14'' as generally shown by arrows 18'' such that one or both of the structural elements 14'' slidably move.

[0139] As described in more detail below, the axial or longitudinal coupling between the structural elements 14'' of adjacent sections 12'', and the design and configuration of the sections 12'' and structural elements 14'' are such that there is minimal or reduced overlapping in the radial or circumferential direction between the structural

elements 14'' in both the non-expanded and expanded states. Thus, the structural elements 14'' are referred to as being axially, longitudinally or non-radially nested.

[0140] Advantageously, the axially nested embodiments of FIGS. 1A and 1B, and others as described, taught or suggested herein, allow suitable crossing profiles (e.g. luminal size) while maintaining desirable radial strength and luminal patency. In the non-expanded state, there is also minimal or reduced overlap between structural elements, so that the luminal size facilitates insertion of a guiding catheter balloon or the like to expand the vascular device. The collapsed profile can also be made very thin without compromising radial strength. Thus, the stent of embodiments of the invention can be deployed in small and difficult to reach vessels, such as the intercranial vessels distal to the carotids and the remote coronary vessels.

[0141] The axially nested embodiments of FIGS. 1A and 1B, and others as described, taught or suggested herein advantageously significantly minimizes radial stacking (overlap) which results in less material thickness in the nondeployed and deployed configurations and thus desirably reduces the effective wall thickness of the deployed stent. Stated differently, the stent substantially eliminates radial overlap between mating structural elements thereby desirably allowing for a low, uniform profile.

[0142] FIG. 2 shows one embodiment of an axially nested slide and lock vascular device, prosthesis or stent 10 having a tubular form with a wall comprising a plurality of generally longitudinally arranged linked circumferential sections, segments or frames 12a, 12s. The stent 10 has a through lumen 20 which is expandable from a first diameter to a second diameter. The stent 10 and/or the lumen 20 have a generally longitudinal axis 24.

[0143] The stent 10 comprises alternately arranged slide and lock sections 12a and linkage sections 12s. Each section 12a includes a pair of male structural elements 14m1, 14m2 and a pair of female structural elements 14f1, 14f2 that respectively slidingly mate via respective interlocking articulating mechanisms 16mf1, 16mf2. In modified embodiments, fewer or more structural elements may be efficaciously utilized, as needed or desired.

[0144] Each linkage section 12s includes a pair of spring elements 22s1, 22s2 with the spring elements 22s1 connected to adjacent female structural elements 14f1, 14f2 and the spring elements 22s2 connected to adjacent male structural elements 14m1, 14m2.

As described further below, the spring elements **22** can allow expansion of the sections **12s** and also allow for deflection of ribs of the structural elements **14** during stent expansion. The spring elements **22** also allow for flexibility in the non-deployed and deployed states. In modified embodiments, fewer or more spring elements may be efficaciously utilized, as needed or desired.

[0145] During stent expansion, there is circumferential relative motion between the mating male structural elements **14m1**, **14m2** and female structural elements **14f1**, **14f2** as generally shown by arrows **18**. One or both of the mating male-female structural elements **14m1**, **14f1** and **14m2**, **14f2** may slidably move apart.

[0146] FIGS. 3 and 4 are partially exploded views of one of the sections **12a**. FIG. 3 shows the section **12a** in a collapsed or undeployed state and FIG. 4 shows the section **12a** in an expanded or deployed state.

[0147] The female structural element **14f1** generally comprises a pair of spaced ribs or arms **26f1** to form a gap **30f1** therebetween. Each of the ribs **26f1** includes an inwardly extending end stop, tooth or tab **32f1** that engage the male structural element **14m1**.

[0148] The female structural element **14f2** generally comprises a pair of spaced ribs or arms **26f2** to form a gap **30f2** therebetween. Each of the ribs **26f2** includes an inwardly extending end stop, tooth or tab **32f2** that engage the male structural element **14m2**.

[0149] The female structural elements **14f1**, **14f2** share a common end portion **28** to which the ribs **26f1** and **26f2** are connected. In one embodiment, the female structural elements **14f1**, **14f2** comprise an integral unit. In modified embodiments, the female structural elements **14f1**, **14f2** can efficaciously be connected by other techniques, as needed or desired.

[0150] The male structural element **14m1** generally comprises a pair of spaced ribs or arms **36m1** to form a gap **40m1** therebetween. In the collapsed state (FIG. 3), the ribs **36m1** extend into the gap **30f1** between the female ribs **26f1**. Each of the ribs **36m1** includes a plurality of outwardly extending spaced stops, teeth or tabs **42m1** that engage the female structural element **14f1** and its stops **32f1**.

[0151] The male structural element **14m2** generally comprises a pair of spaced ribs or arms **36m2** to form a gap **40m2** therebetween. In the collapsed state (FIG. 3), the ribs

36m2 extend into the gap **30f2** between the female ribs **26f2**. Each of the ribs **36m2** includes a plurality of outwardly extending spaced stops, teeth or tabs **42m2** that engage the female structural element **14f2** and its stops **32f2**.

[0152] The male structural elements **14m1**, **14m2** share a common end portion **38** to which the ribs **36m1** and **36m2** are connected. In one embodiment, the male structural elements **14m1**, **14m2** comprise an integral unit. In modified embodiments, the male structural elements **14m1**, **14m2** can efficaciously be connected by other techniques, as needed or desired.

[0153] During expansion, there is circumferential relative motion between the male set of ribs **36m1** and female set of ribs **26f1** with one or both of the sets slidably moving apart. Similarly, there is circumferential relative motion between the male set of ribs **36m2** and female set of ribs **26f2** with one or both of the sets slidably moving apart. The motion is generally denoted by arrows **18**.

[0154] As illustrated by **FIGS. 3** and **4**, during expansion, the stops **32f1**, **32f2** and the respective stops **42m1**, **42m2** cross one another. This is accomplished by utilizing an axially deflecting mechanism. Thus, during "cross-over" the male ribs **36m1** and/or the female ribs **26f1** are respectively deflected outwards and inwards and then resume their original undeflected position. This axial motion is generally denoted by arrows **44**.

[0155] Similarly, during "cross-over" the male ribs **36m2** and/or the female ribs **26f2** are respectively deflected outwards and inwards and then resume their original undeflected position with their axial motion being generally denoted by the arrows **44**. In one embodiment, the spring elements **22s1**, **22s2** facilitate this rib deflection by providing a resilient biasing mechanism to achieve substantially elastic rib deflection or deformation.

[0156] As indicated above, either the male ribs **36m1**, **36m2**, the female ribs **26f1**, **26f2**, both or any other suitable combination of ribs may axially deflect to achieve the desired expansion and other deployment characteristics. The axial deflection is caused by the generation of a generally axial or longitudinal force when the female stops **32f1**, **32f2** and respective male stops **42m1**, **42m2** slide over, engage or abut one another. As discussed further below, at full expansion, a capture mechanism is provided to limit further stent expansion.

[0157] Advantageously, there is substantially no or minimal overlap between nesting male structural elements **14m1**, **14m2** and respective female structural elements **14f1**, **14f2** in both the collapsed state (see, for example, **FIG. 3**) and the expanded state (see, for example, **FIG. 4**). The male ribs **36m1**, **36m2** and respective female ribs **26f1**, **26f2** of a given section **12a** are axially and/or radially displaced from one another and from the ribs or elements of adjacent sections. Thus, the structural elements **14** are referred to as being axially nested since their radial overlap is substantially reduced or minimal.

[0158] **FIG. 5** shows a planar view of the active slide and lock section **12a** connected to an adjacent linkage section **12s**. The linkage section **12s** includes three elements **22s1'**, **22s1''** and **22s2** some or all of which may be spring elements.

[0159] In the embodiment of **FIG. 5**, two independent spring elements **22s1'**, **22s1''** of the linkage section **12s** are connected to a respective one of the female structural elements **14f1**, **14f2** and one spring element **22s2** of the same linkage section **12s** is connected to both the male structural elements **14m1**, **14m2**. In modified embodiments, any suitable number of spring elements **22s** and/or rigid elements may be connected to the male and female structural elements **14m**, **14f** with efficacy, as needed or desired, to control the rib deflection and stent deployment characteristics.

[0160] The female stops **32f1**, **32f2** are configured so that they have generally flat respective end surfaces **46f1**, **46f2** to substantially reduce or minimize recoil and generally tapered respective engaging surfaces **48f1**, **48f2** to facilitate one-way sliding. Similarly, the male stops **42m1**, **42m2** are configured so that they have generally flat respective end surfaces **50m1**, **50m2** to substantially reduce or minimize recoil and generally tapered respective engaging surfaces **52m1**, **52m2** to facilitate one-way sliding. Other suitable configurations that inhibit undesirable recoil and facilitate one-way expansion may be efficaciously utilized, as needed or desired.

[0161] **FIG. 6** shows one embodiment of the female structural element **14f1** including a capture mechanism, device or strap **54f1'** to provide profile capture, containment or control during stent expansion. A similar or other suitable capture mechanism can also be associated with the other female structural element **14f2**.

[0162] The capture strap 54f1' is connected to the female ribs 26f1 and extends therebetween. In one embodiment, the female structural element 14f1 including the capture strap 54f1' comprise an integral unit. In modified embodiments, the capture strap, member or element 54f1' can efficaciously be connected to the ribs 26f1 by other techniques, as needed or desired.

[0163] In the illustrated embodiment of FIG. 6, the capture strap 54f1' is located substantially adjacent to the open end of the gap 30f1 formed between the female ribs 26f1 and substantially adjacent to the end stops 32f1. The capture strap 54f1' permits sliding relative motion between itself (and hence the female structural element 14f1) and the male structural element 14m1 such that the male ribs 36m1 desirably do not jump out of their track during stent deployment.

[0164] The female end stops 32f1 and the male end stops 42m1' are configured to provide engagement that stops further stent expansion. The end stops 42m1' are located adjacent to the open end of the gap 40m1 formed between the ribs 36m1. Any one of a number of suitable locking or lock-out mechanisms may be utilized to control the maximum stent expansion such as tongue and groove arrangements and the like, among others.

[0165] FIGS. 7 and 8 show another embodiment of a capture mechanism, device or strap 54f1" incorporated with the female structural element 14f1 to provide profile control in the non-deployed or collapsed state. A similar or other suitable capture mechanism can also be associated with the other female structural element 14f2. The capture strap 54f1" may be used in conjunction with the capture strap 54f1' (FIG. 6) or independently, as needed or desired.

[0166] The capture strap 54f1" is connected to the female ribs 26f1 and extends therebetween. In one embodiment, the female structural element 14f1 including the capture strap 54f1" comprise an integral unit. In modified embodiments, the capture strap 54f1" can efficaciously be connected to the ribs 26f1 by other techniques, as needed or desired.

[0167] In the illustrated embodiment of FIGS. 7 and 8, the capture strap, member or element 54f1" is located substantially adjacent to the closed end of the gap 30f1 formed between the female ribs 26f1 and substantially at the end portion 28. The capture strap 54f1"

holds the male ribs **36f1** in place in the deployed state and prevents them from jumping out. This desirably maintains the stent profile.

[0168] [0134] In the embodiment of **FIGS. 7 and 8**, the end portion capture strap **54f1** includes a pair of spaced slots or grooves **56f1** through which respective male ribs **36m1** extend. The slots **56f1** are configured to allow slidable relative motion between the ribs **36m1** and slots **56f1** thereby allowing the end stops **42m1** to pass therethrough during stent expansion or deployment. Grooves or tracks may be provided on the inwardly facing surfaces of the female ribs **26f1** that engage the male stops **42m1, 42m1** during stent expansion, thereby preventing the male ribs **36m1** from jumping out and disturbing the stent profile.

[0169] The female end stops **32f1** and the male end stops **42m1** are configured to provide engagement that stops further stent expansion. The end stops **42m1** are located adjacent to the open end of the gap **40m1** formed between the ribs **36m1**. Any one of a number of suitable locking or lock-out mechanisms may be utilized to control the maximum stent expansion such as tongue and groove arrangements and the like, among others.

[0170] **FIG. 9** shows an capture and/or articulation geometry between a male structural element **14m1'** and a female structural element **14f1'** that joins or links adjacent elements **14m1', 14f1'** in accordance with one embodiment. Female rib **26f1'** includes a groove, slot, recess or track **58f1'** through which a portion, stops, teeth or tabs **42m1'** of a male rib **36m1'** slide during stent expansion. Advantageously, this prevents the male rib **36m1'** from jumping out of its track and disturbing the stent profile. The slide or expansion direction is generally denoted by arrows **18**. The groove **58f1'** also keeps the male rib **36m1'** in place in the stent collapsed state.

[0171] **FIG. 10** shows an capture and/or articulation geometry between a male structural element **14m1"** and a female structural element **14f1"** that joins or links adjacent elements **14m1", 14f1"** in accordance with another embodiment. Female rib **26f1"** includes a groove, slot, recess or track **58f1"** through which a portion, stops, teeth or tabs **42m1"** of a male rib **36m1"** slide during stent expansion. Advantageously, this prevents the male rib **36m1"** from jumping out of its track and disturbing the stent profile. The slide or expansion

direction is generally denoted by arrows 18. The groove 58f1" also keeps the male rib 36m1" in place in the stent collapsed state.

[0172] FIG. 11 shows a portion of an axially nested expandable stent section, segment or frame 112' in accordance with one embodiment. The section 112' generally comprises a male structural element 114m' and a female structural element 114f' radially or circumferentially coupled by a slide and lock articulating mechanism 116mf'. During stent expansion, there is circumferential relative motion between the mating male structural element 114m' and female structural element 114f' as generally shown by arrows 118'. One or both of the mating male-female structural elements 114m' and 114f' may slidably move apart.

[0173] The female structural element 114f' generally comprises a pair of ribs or arms 126f' spaced by a gap 130f'. In the collapsed state, at least a portion of the male structural element 114m' extends within the gap 130f'. The male structural element 114m' generally comprises a pair of ribs or arms 136m' spaced by a gap 140m'.

[0174] In the embodiment of FIG. 11, each of the female ribs 126f' includes a plurality of inwardly extending spaced stops, teeth or tabs 132f' that engage the male structural element 114m' and each of the male ribs 136m' includes an outwardly extending end stop, tooth or tab 142m' that engage the female structural element 114f' and its stops 132f'. The stops 132f' and 142m' are configured to permit one-way slidable relative motion between the male and female structural elements 114m', 114f'.

[0175] During stent expansion, the stops 132f' and the stops 142m' cross one another. This is accomplished by utilizing an axially deflecting mechanism. Thus, during "cross-over" the female ribs 126f' and/or the male ribs 136m' are respectively deflected outwards and inwards and then resume their original undeflected position. This axial motion is generally denoted by arrows 144'. In one embodiment, spring elements facilitate this rib deflection by providing a resilient biasing mechanism to achieve substantially elastic rib deflection or deformation.

[0176] As indicated above, either the female ribs 126f', the male ribs 136m', both or any other suitable combination of ribs may axially deflect to achieve the desired expansion and other deployment characteristics. The axial deflection is caused by the generation of a

generally axial or longitudinal force when the female stops **132f'** and respective male stops **142m'** slide over, engage or abut one another. As discussed herein, at full expansion, a hard stop or end capture mechanism is provided to limit further stent expansion.

[0177] Advantageously, there is substantially no or minimal overlap between nesting male structural elements **114m'** and female structural elements **114f'** in both the stent collapsed state and the stent expanded state, and more particularly in the expanded state. The female ribs **126f'** and male ribs **136m'** of a given section **112'** are axially and/or radially displaced from one another and from the ribs or elements of adjacent sections. Thus, the structural elements **114'** are referred to as being axially nested since their radial overlap is substantially reduced or minimal. Multiple slide and lock sections **112'** may be connected axially by suitable linkage sections that may include spring elements, as described above and herein.

[0178] FIG. 12 shows a portion of an axially nested expandable stent section, segment or frame **112''** in accordance with another embodiment. This embodiment illustrates the implementation of additional teeth and lockout points, as discussed further below.

[0179] In one embodiment, the drawing of FIG. 12 illustrates two side-by-side, axial or longitudinal stent sections **112a''** and **112b''** (shown in phantom lead lines). Thus, axially nested stent sections **112a''**, **112b''** and structural elements **114f''**, **114m''** are axially or longitudinally coupled.

[0180] The section **112''** generally comprises a female structural element **114f''** and a male structural element **114m''** radially or circumferentially coupled by a slide and lock articulating mechanism **116mf''**. During stent expansion, there is circumferential relative motion between the mating male structural element **114m''** and female structural element **114f''** as generally shown by arrows **118''**. One or both of the mating male-female structural elements **114m''** and **114f''** may slidably move apart.

[0181] The female structural element **114f''** generally comprises a pair of spaced ribs or arms **126f''** (only one shown). At least a portion of the male structural element **114m''** extends between the female ribs **126f''**. The male structural element **114m''** generally comprises a pair of spaced ribs or arms **136m''** (only one shown).

[0182] In the embodiment of FIG. 12, each of the female ribs 126f” includes a plurality of inwardly extending spaced stops, teeth or tabs 132f” that engage the male structural element 114m” and each of the male ribs 136m” includes a plurality of outwardly extending spaced stops, teeth or tabs 142m” that engage the female structural element 114f” and its stops 132f”. The stops 132f” and 142m” are configured to permit one-way slidable relative motion between the male and female structural elements 114m”, 114f”.

[0183] During stent expansion, the stops 132f” and the stops 142m” cross one another. This is accomplished by utilizing an axially deflecting mechanism. Thus, during “cross-over” the female ribs 126f” and/or the male ribs 136m” are respectively deflected outwards and inwards and then resume their original undeflected position. This axial motion is generally denoted by arrows 144”. In one embodiment, spring elements facilitate this rib deflection by providing a resilient biasing mechanism to achieve substantially elastic rib deflection or deformation.

[0184] As indicated above, either the female ribs 126f”, the male ribs 136m”, both or any other suitable combination of ribs may axially deflect to achieve the desired expansion and other deployment characteristics. The axial deflection is caused by the generation of a generally axial or longitudinal force when the female stops 132f” and respective male stops 142m” slide over, engage or abut one another. As discussed herein, at full expansion, a hard stop or end capture mechanism is provided to limit further stent expansion.

[0185] Advantageously, there is substantially no or minimal overlap between nesting male structural elements 114m” and female structural elements 114f” in both the stent collapsed state and the stent expanded state, and more particularly in the expanded state. The female ribs 126f” and male ribs 136m” of a given section 112” are axially and/or radially displaced from one another and from the ribs or elements of adjacent sections. Thus, the structural elements 114” are referred to as being axially nested since their radial overlap is substantially reduced or minimal. The slide and lock sections 112” may be connected axially by suitable linkage sections that may include spring elements, as described above and herein.

[0186] FIGS. 13A and 13B show a pair of longitudinally arranged and axially nested expandable stent sections, segments or frames 212a', 212b' in accordance with one embodiment. Each section 212a', 212b' comprises at least one structural element 214a', 214b' respectively. Structural elements 214a', 214b' of respective adjacent sections 212a', 212b' are axially or longitudinally coupled to one another by a one-way slide and lock articulating mechanism 216ab'. As discussed further below, one or more capture wings are provided that keeps the parts 214a', 214b' coupled and generally side by side.

[0187] During stent expansion, there is circumferential relative motion between the mating structural element 214a' and structural element 214b' as generally shown by arrows 218'. One or both of the mating structural elements 214a' and 214b' may slidably move apart.

[0188] The structural element 214a' generally comprises a pair of ribs or arms 226a', 236a' spaced by end portions 228a'. The structural element 214b' generally comprises a pair of ribs or arms 226b', 236b' spaced by end portions 228b'. The ribs 236a' and 226b' are axially or longitudinally coupled.

[0189] The rib 236a' includes a slot 260a' along substantially its entire length to create a deflectable member 262a'. The deflectable member 262a' has a plurality of spaced stops, teeth or tabs 242a' that engage the rib 226b' of the structural element 214b'. The rib 226b' has a plurality of spaced stops, teeth or tabs 232b' that engage the opposed stops 242a' during stent expansion. The stops 242a' and 232b' are configured to permit one-way slidable relative motion between the structural elements 214a', 214b'.

[0190] During stent expansion, the stops 242a' and the stops 232b' cross one another. This is accomplished by utilizing an axially deflecting mechanism. Thus, during "cross-over" the deflectable member 262a' is deflected and then resumes its original undeflected position. This axial motion is generally denoted by arrows 244'. The axial deflection is caused by the generation of a generally axial or longitudinal force when the stops 242a' and respective stops 232b' slide over, engage or abut one another. In a modified embodiment, spring elements may facilitate rib deflection by providing a resilient biasing mechanism to achieve substantially elastic rib deflection or deformation.

[0191] The rib **226b'** further includes a overlapping capture wings or elements **264b'** and **266b'** that axially or longitudinally connect the ribs **226b'** and **236a'**. The capture wing **264b'** is raised relative to the stops **242a'**, **232b'** and extends over the deflectable member **262a'**. The capture wing **266b'** is lowered relative to the stops **242a'**, **232b'** and extends below the deflectable member **262a'**. Any number of capture wings may be utilized with efficacy, as needed or desired.

[0192] The capture wings **264b'**, **266b'** maintain a coupling between the structural elements **214a'**, **214b'** and keep them in a generally side by side plane in the collapsed state and as the stent expands. As discussed herein, at full expansion, a hard stop or end capture mechanism is provided to limit further stent expansion.

[0193] The rib **226a'** is generally similar in structure to the rib **226b'** and includes stops, teeth or tabs **232a'**, overlapping capture wings or elements **264a'** and **266a'**. The rib **236b'** is generally similar in structure to the rib **236a'** and includes stops, teeth or tabs **242b'**, a slot **260b'** and a deflectable member **262b'**.

[0194] Advantageously, there is substantially no or minimal overlap between axially nesting structural elements **214a'** and **214b'** in both the stent collapsed state and the stent expanded state, and more particularly in the expanded state. The articulating ribs **236a'**, **226b'** of axially adjacent structural elements **214a'**, **214b'** are axially displaced from one another. Also, the ribs and elements of a given section **212'** are axially and/or radially displaced from one another and from the ribs or elements of adjacent sections. Thus, the structural elements **214'** are referred to as being axially nested since their radial overlap is substantially reduced or minimal. The slide and lock sections **212'** may also be connected axially by suitable linkage sections that may include spring elements, as described above and herein.

[0195] FIGS. 14A and 14B show a pair of longitudinally arranged and axially nested expandable stent sections, segments or frames **212a''**, **212b''** in accordance with another embodiment. Each section **212a''**, **212b''** comprises at least one structural element **214a''**, **214b''** respectively. Structural elements **214a''**, **214b''** of respective adjacent sections **212a''**, **212b''** are axially or longitudinally coupled to one another by a one-way slide and

lock articulating mechanism **216ab**". As discussed further below, one or more capture wings are provided that keeps the parts **214a**", **214b**" coupled and generally side by side.

[0196] During stent expansion, there is circumferential relative motion between the mating structural element **214a**" and structural element **214b**" as generally shown by arrows **218**". One or both of the mating structural elements **214a**" and **214b**" may slidably move apart.

[0197] The structural element **214a**" generally comprises a pair of ribs or arms **226a**", **236a**" spaced by end portions **228a**". The structural element **214b**" generally comprises a pair of ribs or arms **226b**", **236b**" spaced by end portions **228b**". The ribs **236a**" and **226b**" are axially or longitudinally coupled.

[0198] The rib **236a**" has a plurality of spaced stops, teeth or tabs **242a**" that engage the rib **226b**" of the structural element **214b**". The rib **226b**" has a plurality of spaced stops, teeth or tabs **232b**" that engage the opposed stops **242a**" during stent expansion. The stops **242a**" and **232b**" are configured to permit one-way slidable relative motion between the structural elements **214a**", **214b**".

[0199] The embodiment of FIGS. 14A and 14B utilizes a substantially axial deflecting mechanism during stent expansion in which the structural elements **214a**", **214b**" and/or the sections **212a**", **212b**" are deflectable in substantially their entirety. This may be accomplished by utilizing spring linkage elements or the like that facilitate element deflection by providing a resilient biasing mechanism to achieve substantially elastic deflection or deformation.

[0200] During stent expansion, the stops **242a**" and the stops **232b**" cross one another. This is accomplished by utilizing an axially deflecting mechanism. Thus, during "cross-over" the structural element **236a**" is deflected and then resumes its original undeflected position. This axial motion is generally denoted by arrows **244**". The axial deflection is caused by the generation of a generally axial or longitudinal force when the generally rigid stops **242a**" and associated generally rigid stops **232b**" slide over, engage or abut one another

[0201] The rib **226b**" further includes overlapping capture wings or elements **264b**" and elements **266b**" that axially or longitudinally connect the ribs **226b**" and **236a**".

The capture wings **264b**" are raised relative to the stops **242a**", **232b**" and extend over the rib **236a**". The capture wing **266b**" is lowered relative to the stops **242a**", **232b**" and extends below the rib **236a**". Any number of capture wings may be utilized with efficacy, as needed or desired.

[0202] The capture wings **264b**", **266b**" maintain a coupling between the structural elements **214a**", **214b**" and keep them in a generally side by side plane in the collapsed state and as the stent expands. As discussed herein, at full expansion, a hard stop or end capture mechanism is provided to limit further stent expansion.

[0203] The rib **226a**" is generally similar in structure to the rib **226b**" and includes stops, teeth or tabs **232a**", overlapping capture wings or elements **264a**" and **266a**". The rib **236b**" is generally similar in structure to the rib **236a**' and includes stops, teeth or tabs **242b**".

[0204] Advantageously, there is substantially no or minimal overlap between axially nesting structural elements **214a**" and **214b**" in both the stent collapsed state and the stent expanded state, and more particularly in the expanded state. The articulating ribs **236a**", **226b**" of axially adjacent structural elements **214a**", **214b**" are axially displaced from one another. Also, the ribs and elements of a given section **212**" are axially and/or radially displaced from one another and from the ribs or elements of adjacent sections. Thus, the structural elements **214**" are referred to as being axially nested since their radial overlap is substantially reduced or minimal. The slide and lock sections **212**" may also be connected axially by suitable linkage sections that may include spring elements, as described above and herein.

[0205] FIG. 15 shows a portion of an axially nested expandable stent section, segment or frame **312**' in accordance with one embodiment. The section **312**' generally comprises a male structural element **314m**' and a female structural element **314f**' radially or circumferentially coupled by a slide and lock articulating mechanism **316mf**'. During stent expansion, there is circumferential relative motion between the mating male structural element **314m**' and female structural element **314f**' as generally shown by arrows **318**'. One or both of the mating male-female structural elements **314m**' and **314f**' may slidably move apart.

[0206] The female structural element 314f' generally comprises a pair of spaced ribs or arms 326f' (only one shown). At least a portion of the male structural element 314m' extends between the female ribs 326f'. The male structural element 314m' generally comprises a pair of spaced ribs or arms 336m' (only one shown).

[0207] In the embodiment of FIG. 15, each of the female ribs 326f' includes a plurality of spaced stops, teeth or tabs 332f' that engage the male structural element 314m' and each of the male ribs 336m' includes a plurality of spaced stops, teeth or tabs 342m' that engage the female structural element 314f' and its stops 332f'. The stops 332f' and 342m' are configured to permit one-way slidable relative motion between the male and female structural elements 314m', 314f'.

[0208] During stent expansion, the stops 332f' and the stops 342m' cross or slide over one another. This is accomplished by utilizing a radially deflecting mechanism. Thus, during "cross-over" the female ribs 326f' and/or the male ribs 336m' are deflected radially and then resume their original undeflected position. This radial motion is generally denoted by arrows 344'. In one embodiment, spring elements facilitate this rib deflection by providing a resilient biasing mechanism to achieve substantially elastic rib deflection or deformation.

[0209] As indicated above, either the female ribs 326f', the male ribs 336m', both or any other suitable combination of ribs may radially deflect to achieve the desired expansion and other deployment characteristics. The radial deflection is caused by the generation of a generally radial force when the female stops 332f' and respective male stops 342m' slide over, engage or abut one another. As discussed herein, at full expansion, a hard stop or end capture mechanism is provided to limit further stent expansion.

[0210] Advantageously, there is substantially minimal overlap between nesting male structural elements 314m' and female structural elements 314f' in both the stent collapsed state and the stent expanded state, and more particularly in the expanded state. The radial thickness of overlapping stops or elements 332f', 342m' is between about the same as the stent material nominal thickness and about two times the stent material nominal thickness. The female ribs 326f' and male ribs 336m' of a given section 312' are substantially axially and/or radially displaced from one another and from the ribs or elements

of adjacent sections. Thus, the structural elements **314'** are referred to as being axially nested since their radial overlap is substantially reduced or minimal. The slide and lock sections **312'** may be connected axially by suitable linkage sections that may include spring elements, as described above and herein.

[0211] In one embodiment, the drawing of **FIG. 15** illustrates two substantially side-by-side, axial or longitudinal stent sections **312a'** and **312b'** (shown in phantom lead lines). Thus, axially nested stent sections **312a'**, **312b'** and structural elements **314f'**, **314m'** are axially or longitudinally coupled with minimal radial overlap. The radial thickness of overlapping stops, teeth or elements **332f'**, **342m'** is between about the same as the stent material nominal thickness and about two times the stent material nominal thickness.

[0212] **FIG. 16** shows an axially nested expandable stent section, segment or frame **312''** in accordance with another embodiment. **FIG. 17** is an enlarged view of the axially, longitudinally or non-radially overlapping design mechanism in a locked position and **FIG. 18** is an enlarged view showing radial rib deflection in a sliding position.

[0213] The section **312''** includes a pair of male structural elements **314m1''**, **314m2''** and a pair of female structural elements **314f1''**, **314f2''** that respectively slidably mate via respective interlocking articulating mechanisms **316mf1''**, **316mf2''**. In modified embodiments, fewer or more structural elements may be efficaciously utilized, as needed or desired.

[0214] During stent expansion, there is circumferential relative motion between the mating male structural elements **314m1''**, **314m2''** and female structural elements **314f1''**, **314f2''** as generally shown by arrows **318''**. One or both of the mating male-female structural elements **314m1''**, **314f1''** and **314m2''**, **314f2''** may slidably move apart.

[0215] The female structural element **314f1''** generally comprises a pair of spaced ribs or arms **326f1''** to form a gap **330f1''** therebetween. Each of the ribs **326f1''** includes a plurality of spaced radially extending stops, teeth or tabs **332f1''** that engage the male structural element **314m1''**.

[0216] The female structural element **314f2''** generally comprises a pair of spaced ribs or arms **326f2''** to form a gap **330f2''** therebetween. Each of the ribs **326f2''** includes a

plurality of spaced radially extending stops, teeth or tabs 332f2" that engage the male structural element 314m2".

[0217] The female structural elements 314f1", 314f2" share a common end portion 328" to which the ribs 326f1" and 326f2" are connected. In one embodiment, the female structural elements 314f1", 314f2" comprise an integral unit. In modified embodiments, the female structural elements 314f1", 314f2" can efficaciously be connected by other techniques, as needed or desired.

[0218] The male structural element 314m1" generally comprises a rib or arm 336m1" with a pair of axially extending stops, teeth, tabs or wings 342m1" that engage the female structural element 314f1" and its stops 332f1". In the collapsed and partially expanded states, the rib 336m1" extends into the gap 330f1" between the female ribs 326f1". The stops 332f1", 342m1" are configured to permit one-way slidable relative motion between the male and female structural elements 314m1", 314f1".

[0219] The male structural element 314m2" generally comprises a rib or arm 336m2" with a pair of axially extending stops, teeth, tabs or wings 342m2" that engage the female structural element 314f2" and its stops 332f2". In the collapsed and partially expanded states, the rib 336m2" extends into the gap 330f2" between the female ribs 326f2". The stops 332f2", 342m2" are configured to permit one-way slidable relative motion between the male and female structural elements 314m2", 314f2".

[0220] The male structural elements 314m1", 314m2" can share a common end portion to which the ribs 336m1" and 336m2" are connected. In one embodiment, the male structural elements 314m1", 314m2" comprise an integral unit. In modified embodiments, the male structural elements 314m1", 314m2" can efficaciously be connected by other techniques, as needed or desired.

[0221] During stent expansion, there is circumferential relative motion between the female ribs 326f1" and male rib 336m1" with one or both slidably moving apart. Similarly, there is circumferential relative motion between the female ribs 326f2" and male rib 336m2" with one or both slidably moving apart. The motion is generally denoted by arrows 318".

[0222] The female stops 332f1", 332f2" are configured so that they have generally flat respective end surfaces 346f1", 346f2" to substantially reduce or minimize recoil and generally tapered respective engaging surfaces 348f1", 348f2" to facilitate one-way sliding. The male stops 342m1", 342m2" may also be similarly configured to substantially reduce or minimize recoil and facilitate one-way sliding. Other suitable configurations that inhibit undesirable recoil and facilitate one-way expansion may be efficaciously utilized, as needed or desired.

[0223] During stent expansion, the stops 332f1" and the stops 342m1" cross or slide over one another. This is accomplished by utilizing a radially deflecting mechanism. Thus, and as illustrated by FIGS. 17 and 18, during "cross-over" the female ribs 326f1" and/or the male rib 336m1" are deflected radially and then resume their original undeflected position. This radial motion is generally denoted by arrows 344".

[0224] Similarly, during stent expansion, the stops 332f2" and the stops 342m2" cross or slide over one another. This is accomplished by utilizing a radially deflecting mechanism. Thus, during "cross-over" the female ribs 326f2" and/or the male rib 336m2" are deflected radially and then resume their original undeflected position. This radial motion is generally denoted by arrows 344". In one embodiment, spring elements facilitate the rib deflection by providing a resilient biasing mechanism to achieve substantially elastic rib deflection or deformation.

[0225] As indicated above, either the female ribs 326f1", 326f2", the male ribs 336m1", 336m2", both or any other suitable combination of ribs may radially deflect to achieve the desired expansion and other deployment characteristics. The radial deflection is caused by the generation of a generally radial force when the female stops 332f1", 332f2" and respective male stops 342m1", 342m2" slide over, engage or abut one another. As discussed herein, at full expansion, a hard stop or end capture mechanism is provided to limit further stent expansion.

[0226] Advantageously, there is substantially minimal overlap between nesting male structural elements 314m1", 314m2" and respective female structural elements 314f1", 314f2" in both the stent collapsed state and the stent expanded state, and more particularly in the expanded state. The radial thickness of overlapping elements 314m1", 314f1" and

314m2", **314f2**" is between about the same as the stent material nominal thickness and about two times the stent material nominal thickness. The female ribs **326f**" and male rib(s) **336m**" of a given section **312**" are substantially axially and/or radially displaced from one another and from the ribs or elements of adjacent sections. Thus, the structural elements **314**" are referred to as being axially nested since their radial overlap is substantially reduced or minimal. The slide and lock sections **312**" may be connected axially by suitable linkage sections that may include spring elements, as described above and herein.

[0227] **FIGS. 19** and **20** show a portion of an axially nested expandable stent section, segment or frame **412** in accordance with one embodiment. **FIG. 19** illustrates a stent collapsed state and **FIG. 20** illustrates a stent expanded state.

[0228] The section **412** generally comprises a male structural element **414m** and a female structural element **414f** radially or circumferentially coupled by a slide and lock articulating mechanism **416mf**. During stent expansion, there is circumferential relative motion between the mating male structural element **414m** and female structural element **414f** as generally shown by arrows **418**. One or both of the mating male-female structural elements **414m** and **414f** may slidably move apart.

[0229] The female structural element **414f** generally comprises a pair of ribs or arms **426f** spaced by an end portion **428** to form a gap **430f** therebetween. In the collapsed state, at least a portion of the male structural element **414m** extends within the gap **430f**.

[0230] The male structural element **414m** generally comprises a main rib or arm **436** that bifurcates or divides into two ribs or arms **436m**. The ribs **436m** are spaced by a proximal end portion **438m1** and distal end portion **438m2** to form a gap **440m** therebetween.

[0231] In the embodiment of **FIGS. 19** and **20**, each of the female ribs **426f** includes a plurality of inwardly extending spaced deflectable fingers or elements **431f** that extend into the gap **430f**. The fingers **431f** terminate in stops, teeth or tabs **432f** that engage the male structural element **414m**.

[0232] Each of the male ribs **436m** includes an outwardly extending end stop, tooth or tab **442m** that engage the female structural element **414f** and its stops **432f**. The stops **432f** and **442m** are configured to permit one-way slidable relative motion between the male and female structural elements **414m**, **414f**. The stops **432f** are arranged in an

alternating repetitive or staggered pattern for enhanced resolution and greater selection and adaptability in expansion size.

[0233] The female stops **432f** are configured so that they have generally flat respective end surfaces **446f** to substantially reduce or minimize recoil and generally tapered respective engaging surfaces **448f** to facilitate one-way sliding. Similarly, the male stops **442m** are configured so that they have generally flat respective end surfaces **450m** to substantially reduce or minimize recoil and generally tapered respective engaging surfaces **452m** to facilitate one-way sliding. Other suitable configurations that inhibit undesirable recoil and facilitate one-way expansion may be efficaciously utilized, as needed or desired.

[0234] During stent expansion, the stops **432f** and the stops **442m** cross one another. This is accomplished by utilizing an axially deflecting mechanism. Thus, during "cross-over" the male stop engaging fingers **431f** deflected generally axially outwards and then resume their original undeflected position. This axial motion is generally denoted by arrows **444**. Alternatively, or in addition, deflectable fingers or elements may be provided on the male structural element **414m**.

[0235] The axial deflection is caused by the generation of a generally axial or longitudinal force when the female stops **432f** and respective male stops **442m** slide over, engage or abut one another. As discussed herein, at full expansion, a hard stop or end capture mechanism is provided to limit further stent expansion.

[0236] Advantageously, there is substantially no or minimal overlap between nesting male structural elements **414m** and female structural elements **414f** in both the stent collapsed state and the stent expanded state, and more particularly in the expanded state. The female ribs **426f** and male ribs **436**, **436m** of a given section **412** are axially and/or radially displaced from one another and from the ribs or elements of adjacent sections. Thus, the structural elements **414** are referred to as being axially nested since their radial overlap is substantially reduced or minimal. Multiple slide and lock sections **412** may be connected axially by suitable linkage sections that may include spring elements, as described above and herein.

Some Stent Embodiments

[0237] FIGS. 21-27 show conceptual views of embodiments of expandable axially nested slide and lock vascular devices, prostheses or stents **510** in deployed and undeployed states. The stent **510** has a tubular form with a wall comprising a plurality of generally longitudinally arranged linked circumferential sections, segments or frames **512a**, **512s**. The stent **510** has a through lumen **520** which is expandable from a first diameter to a second diameter. The stent **510** and/or the lumen **520** have a generally longitudinal axis **524**.

[0238] Advantageously, the axially nested embodiments of the stent **510** allow suitable crossing profiles (e.g. luminal size) while maintaining desirable radial strength and luminal patency. In the non-expanded state, there is also minimal or reduced overlap between structural elements, so that the luminal size facilitates insertion of a guiding catheter balloon or the like to expand the vascular device.

[0239] The stent **510** comprises alternately arranged slide and lock sections **512a** and linkage sections **512s**. Each section **512a** includes a pair of male structural elements **514m1**, **514m2** and a pair of female structural elements **514f1**, **514f2** that each slidingly mate with the male structural elements **514m1**, **514m2** via respective interlocking articulating mechanisms **516mf1**, **516mf2**. (Each of the structural elements **514** may also be described as comprising two structural elements since each mates at two circumferential locations.)

[0240] As conceptually illustrated in FIG. 21, the articulating mechanisms may comprise radially deflecting locking mechanisms **516r** (arrows **544r**) or axially (laterally) deflecting locking mechanisms **516a** (arrows **544a**). The number of structural elements in a section and/or the number of sections in a stent may be efficaciously varied and selected, as needed or desired.

[0241] The axial or longitudinal coupling between the structural elements **514** of adjacent sections **512a**, the radial coupling between structural elements **514** of the same section **512a**, and the design and configuration of the sections **512** and structural elements **514** are such that there is minimal or reduced overlapping in the radial or circumferential direction between the structural elements **514** in both the non-expanded and expanded states. Thus, the structural elements **514**, sections **512** and/or stent **510** are referred to as being

axially, longitudinally or non-radially nested. (There is also minimal or reduced radial overlap between linkage elements 522 of the same and adjacent sections 512s in both the undeployed and deployed states.)

[0242] One of the stent sections 512a' generally comprises male structural elements 514m1', 514m2' and female structural elements 514f1', 514f2'. The proximate stent section 512a'' generally includes male structural elements 514m1'', 514m2'' and female structural elements 514f1'', 514f2''. (The sections 512a', 512a'' are generally similar in structure except for being angularly offset and this nomenclature is used in some instances to provide a more clear description – the use of 512a encompasses one or both of 512a' and 512a'' as does other similar use of 'prime' and "double-prime".)

[0243] The female structural element 514f1' generally comprises a pair of ribs or arms 526f1' spaced by end portions 528f11', 528f12'. As discussed above and below herein, the end portions 528f11', 528f12' have slide and lock articulating mechanisms such as tongue-groove configuration stops, tabs or teeth that engage respective male structural elements 514m1', 514m2' to provide radially and/or axially deflecting mechanisms for stent expansion and lock-out.

[0244] The female structural element 514f2' generally comprises a pair of ribs or arms 526f2' spaced by end portions 528f21', 528f22'. As discussed above and below herein, the end portions 528f21', 528f22' have slide and lock articulating mechanisms such as tongue-groove configuration stops, tabs or teeth that engage respective female structural elements 514m2', 514m1' to provide radially and/or axially deflecting mechanisms for stent expansion and lock-out.

[0245] The male structural element 514m1' generally comprises a rib or arm 536m11' and a pair of spaced ribs or arms 536m12' extending in a direction opposite to the rib 536m11'. The ribs 536m11', 536m12' share a common end portion 538m1'. In the stent collapsed state, the male rib 536m11' extends in the gap between the female ribs 526f1' and the male ribs 536m12' extend in the gap between the female ribs 526f2'.

[0246] As discussed above and below herein, the ribs 536m11', 536m12' have slide and lock articulating mechanisms such as tongue-groove configuration stops, tabs or teeth that engage respective female structural elements 514f1', 514f2' to provide radially

and/or axially deflecting mechanisms for stent expansion and lock-out. More specifically, the ribs 536m11', 536m12' engage respective female end portions 528f11', 528f22'.

[0247] The male structural element 514m2' generally comprises a rib or arm 536m21' and a pair of spaced ribs or arms 536m22' extending in a direction opposite to the rib 536m21'. The ribs 536m21', 536m22' share a common end portion 538m2'. In the stent collapsed state, the male rib 536m21' extends in the gap between the female ribs 526f2' and the male ribs 536m22' extend in the gap between the female ribs 526f1'.

[0248] As discussed above and below herein, the ribs 536m21', 536m22' have slide and lock articulating mechanisms such as tongue-groove configuration stops, tabs or teeth that engage respective female structural elements 514f2', 514f1' to provide radially and/or axially deflecting mechanisms for stent expansion and lock-out. More specifically, the ribs 536m21', 536m22' engage respective female end portions 528f21', 528f12'.

[0249] The female structural element 514f1'' generally comprises a pair of ribs or arms 526f1'' spaced by end portions 528f11'', 528f12''. As discussed above and below herein, the end portions 528f11'', 528f12'' have slide and lock articulating mechanisms such as tongue-groove configuration stops, tabs or teeth that engage respective male structural elements 514m2'', 514m1'' to provide radially and/or axially deflecting mechanisms for stent expansion and lock-out.

[0250] The female structural element 514f2'' generally comprises a pair of ribs or arms 526f2'' spaced by end portions 528f21'', 528f22''. As discussed above and below herein, the end portions 528f21'', 528f22'' have slide and lock articulating mechanisms such as tongue-groove configuration stops, tabs or teeth that engage respective male structural elements 514m1'', 514m2'' to provide radially and/or axially deflecting mechanisms for stent expansion and lock-out.

[0251] The male structural element 514m1'' generally comprises a rib or arm 536m11'' and a pair of spaced ribs or arms 536m12'' extending in a direction opposite to the rib 536m11''. The ribs 536m11'', 536m12'' share a common end portion 538m1''. In the stent collapsed state, the male rib 536m11'' extends in the gap between the female ribs 526f2'' and the male ribs 536m12'' extend in the gap between the female ribs 526f1''.

[0252] As discussed above and below herein, the ribs 536m11", 536m12" have slide and lock articulating mechanisms such as tongue-groove configuration stops, tabs or teeth that engage respective female structural elements 514f2", 514f1" to provide radially and/or axially deflecting mechanisms for stent expansion and lock-out. More specifically, the ribs 536m11", 536m12" engage respective female end portions 528f21", 528f12".

[0253] The male structural element 514m2" generally comprises a rib or arm 536m21" and a pair of spaced ribs or arms 536m22" extending in a direction opposite to the rib 536m21". The ribs 536m21", 536m22" share a common end portion 538m2". In the stent collapsed state, the male rib 536m21" extends in the gap between the female ribs 526f1" and the male ribs 536m22" extend in the gap between the female ribs 526f2".

[0254] As discussed above and below herein, the ribs 536m21", 536m22" have slide and lock articulating mechanisms such as tongue-groove configuration stops, tabs or teeth that engage respective female structural elements 514f1", 514f2" to provide radially and/or axially deflecting mechanisms for stent expansion and lock-out. More specifically, the ribs 536m21", 536m22" engage respective female end portions 528f11", 528f22".

[0255] Each linkage section 512s includes a plurality of elements 522 and connects adjacent stent sections 512a' and 512a". One or more of the linkage elements 522 may comprise spring elements. The spring elements 522 provide flexibility and allow expansion of the linkage sections 512s along with stent expansion. The spring elements 522 also allow for radial and/or axial rib deflection during stent expansion to a deployed state. The spring elements 522 facilitate this rib deflection by providing a resilient biasing mechanism to achieve substantially elastic rib deflection or deformation.

[0256] In one embodiment, each linkage section 512s generally comprises four linkage elements 522m1, 522m2, 522f1, 522f2. In modified embodiments, fewer or more linkage elements may be efficaciously utilized, as needed or desired.

[0257] The linkage elements 522m1 axially or longitudinally connect the male structural elements 514m1 (514m1', 514m1"). In one embodiment, the linkage elements 522m1 and the male structural elements 514m1 comprise an integral unit. In modified embodiments, the linkage elements 522m1 and the male structural elements 514m1 can efficaciously be connected by other techniques, as needed or desired.

[0258] The linkage elements **522m2** axially or longitudinally connect the male structural elements **514m2** (**514m2'**, **514m2''**). In one embodiment, the linkage elements **522m2** and the male structural elements **514m2** comprise an integral unit. In modified embodiments, the linkage elements **522m2** and the male structural elements **514m2** can efficaciously be connected by other techniques, as needed or desired.

[0259] The linkage elements **522f1** axially or longitudinally connect the female structural elements **514f1** (**514f1'**, **514f1''**). In one embodiment, the linkage elements **522f1** and the female structural elements **514f1** comprise an integral unit. In modified embodiments, the linkage elements **522f1** and the female structural elements **514f1** can efficaciously be connected by other techniques, as needed or desired.

[0260] The linkage elements **522f2** axially or longitudinally connect the female structural elements **514f2** (**514f2'**, **514f2''**). In one embodiment, the linkage elements **522f2** and the female structural elements **514f2** comprise an integral unit. In modified embodiments, the linkage elements **522f2** and the female structural elements **514f2** can efficaciously be connected by other techniques, as needed or desired.

[0261] During stent expansion, there is circumferential relative motion between the mating male structural elements **514m1**, **514m2** and female structural elements **514f1**, **514f2** as generally shown by arrows **518**. One or both of the male structural elements **514m1**, **514m2**, one or both of the female structural elements **514f1**, **514f2**, both the male and female structural elements **514m1**, **514m2**, **514f1**, **514f2**, or any suitable combination thereof may slidably move apart.

[0262] More specifically, during expansion, there is circumferential relative motion between: the female ribs **526f1'** and the male rib **536m11'** with one or both slidably moving apart; the female ribs **526f1'** and the male ribs **536m22'** with one or both slidably moving apart; the female ribs **526f2'** and the male rib **536m21'** with one or both slidably moving apart; and the female ribs **526f2'** and the male ribs **536m12'** with one or both slidably moving apart. The motion is generally denoted by arrows **518**.

[0263] Similarly, during stent expansion, there is circumferential relative motion between: the female ribs **526f1''** and the male rib **536m21''** with one or both slidably moving apart; the female ribs **526f1''** and the male ribs **536m12''** with one or both slidably moving

apart; the female ribs **526f2**" and the male rib **536m11**" with one or both slidably moving apart; and the female ribs **526f2**" and the male ribs **536m22**" with one or both slidably moving apart. The motion is generally denoted by arrows **518**.

[0264] As discussed herein, at full expansion, a hard stop or end capture mechanism is provided to limit further stent expansion. Each section **512a** can comprise one or more end capture mechanisms such as hard stops, straps or other suitable devices that prevent further expansion between mating male and female structural elements **514m** and **514f**.

[0265] Advantageously, there is substantially no or minimal overlap between nesting male structural elements **514m** and associated female structural elements **514f** in both the collapsed state and the expanded state, and more particularly in the expanded state. For example, for a given stent section **512a'**, in the collapsed state the female ribs **526f1'** and the male ribs **536m11'**, **536m22'** are substantially axially or longitudinally displaced or offset while in the expanded state the same are substantially radially or circumferentially displaced or offset, thereby minimizing radial overlap in both the collapsed and expanded states.

[0266] Also, for axially displaced stent sections **512a'** and **512a"**, for example, the female ribs **526f1'** and the male rib **536m1"** are substantially axially or longitudinally displaced or offset from the female ribs **526f1"** and male ribs **536m12"**. Thus, the stent **510**, its sections **512a** and/or structural elements **514** are referred to as being axially nested since their radial overlap is substantially reduced or minimal in both the collapsed and expanded states.

[0267] Referring in particular to **FIGS. 24** and **27**, the stent **510** has a minor inner collapsed diameter $D_{i-collapsed}$, a major outer collapsed diameter $D_{o-collapsed}$, a minor inner expanded diameter $D_{i-expanded}$ and a major outer expanded diameter $D_{o-expanded}$. The stent wall curvature decreases as the stent **510** expands, but its radius of curvature increases.

[0268] The stent wall has a minimum thickness T_{min} and a maximum thickness T_{max} . The thicknesses T_{min} and thickness T_{max} remain substantially unchanged in the collapsed and expanded states. In one embodiment, the minimum thickness T_{min} is the thickness of the male structural elements **514m** and the maximum T_{max} is the thickness of the female structural elements **514f**. If the thickness T_{min} is considered to be the nominal

material thickness then, in one embodiment, the maximum wall thickness is given by, where k is embodiment dependent:

$$T_{\min} < T_{\max} \leq kT_{\min}$$

[0269] In one embodiment k is about two (2). In another embodiment, k is in the range from about 1.5 to about 3, including all values and sub-ranges therebetween. In yet another embodiment, k is in the range from about 1.25 to about 5, including all values and sub-ranges therebetween. In modified embodiments, other suitable values and/or ranges of k may be efficaciously utilized, as needed or desired.

[0270] Embodiments of the invention provide an axially nested vascular device 510 to achieve both competitive crossing profiles (e.g. luminal size) while maintaining other key features, such as, for example, radial strength and luminal patency. Advantageously, an axially nested device design allows for use of thicker materials to maintain radial strength, as needed or desired.

[0271] The maximum thickness T_{\max} is substantially the same in both the collapsed and expanded states. Thus, in the collapsed state, there is also minimal or reduced overlap between structural elements (e.g., 514m, 514f), so that the luminal size facilitates insertion of a guiding catheter balloon or the like to expand the vascular device.

[0272] During manufacture and assembly of the axially nested embodiments, the device structural elements (e.g., 514m, 514f) and/or ribs (e.g. the female ribs 526f1' and the male ribs 536m11', 536m22') are positioned side by side (axially) in the predilated or non-expanded state to substantially reduce or minimize the device crossing profile and bulk in both the undeployed (non-expanded, predilated) and deployed (expanded, dilated) states. Advantageously, by substantially reducing or eliminating the excess bulk typically encountered with a radially nesting device design, embodiments of the invention can be used to achieve competitive devices and crossing profiles with a wide variety of materials at a wide variety of thicknesses, thereby desirably allowing for optimum device design and performance.

[0273] FIGS. 28-37 show different views of the axially nested slide and lock vascular device, prosthesis or stent 510. These drawings illustrate, among other things, features of the articulating slide and lock mechanisms, deflecting arm mechanisms and

capture mechanisms at full expansion in accordance with some embodiments of the stent 510.

[0274] The male rib 536m11' includes a plurality of outwardly extending stops, tabs or teeth 542m11' that extend on both sides of the rib 536m11'. The stops 542m11' engage the female structural element 514f1' in a one-way slide and lock articulating motion.

[0275] The male stops 542m11' are configured so that they have generally flat end surfaces 550m11' to substantially reduce or minimize recoil and generally tapered engaging surfaces 552m11' to facilitate one-way sliding (see, for example, FIGS. 31 and 33). Other suitable configurations that inhibit undesirable recoil and facilitate one-way expansion may be efficaciously utilized, as needed or desired.

[0276] The male rib 536m11' also includes a pair of outwardly extending end stops, tabs, wings or teeth 542m11e' with one each extending on each sides of the rib 536m11'. The end stops 542m11e' engage a capture mechanism of the female structural element 514f1' to control and limit the maximum stent expansion.

[0277] The end stops 542m11e' have generally flat engaging surfaces 552m11e' that facilitate lock-out and capture at full expansion (see, for example, FIGS. 31 and 33). Other suitable lock-out and capture configurations may be efficaciously utilized, as needed or desired.

[0278] Each of the male ribs 536m12' includes a plurality of outwardly extending stops, tabs or teeth 542m12'. The stops 542m12' engage the female structural element 514f2' in a one-way slide and lock articulating motion.

[0279] The male stops 542m12' are configured so that they have generally flat end surfaces 550m21' to substantially reduce or minimize recoil and generally tapered engaging surfaces 552m21' to facilitate one-way sliding (see, for example, FIG. 34). Other suitable configurations that inhibit undesirable recoil and facilitate one-way expansion may be efficaciously utilized, as needed or desired.

[0280] In one embodiment, one or both of the male ribs 536m12' include one or more inwardly extending stops, tabs or teeth 542m12i' (see, for example, FIG. 34). These stops 542m12i' are configured to allow only one-way sliding and provide a mechanism to substantially reduce or minimize recoil.

[0281] Each of the male ribs 536m12' also includes an outwardly extending end stop, tab, wing or tooth 542m12e'. The end stops 542m12e' engage a capture mechanism of the female structural element 514f2' to control and limit the maximum stent expansion.

[0282] The end stops 542m12e' have generally flat engaging surfaces 552m12e' that facilitate lock-out and capture at full expansion (see, for example, FIG. 34). Other suitable lock-out and capture configurations may be efficaciously utilized, as needed or desired.

[0283] The male rib 536m21' includes a plurality of outwardly extending stops, tabs or teeth 542m21' that extend on both sides of the rib 536m21'. The stops 542m21' engage the female structural element 514f2' in a one-way slide and lock articulating motion.

[0284] The male stops 542m21' are configured so that they have generally flat end surfaces 550m21' to substantially reduce or minimize recoil and generally tapered engaging surfaces 552m21' to facilitate one-way sliding (see, for example, FIG. 34). Other suitable configurations that inhibit undesirable recoil and facilitate one-way expansion may be efficaciously utilized, as needed or desired.

[0285] The male rib 536m21' also includes a pair of outwardly extending end stops, tabs, wings or teeth 542m21e' with one each extending on each sides of the rib 536m21'. The end stops 542m21e' engage a capture mechanism of the female structural element 514f2' to control and limit the maximum stent expansion.

[0286] The end stops 542m21e' have generally flat engaging surfaces 552m21e' that facilitate lock-out and capture at full expansion (see, for example, FIG. 32). Other suitable lock-out and capture configurations may be efficaciously utilized, as needed or desired.

[0287] Each of the male ribs 536m22' includes a plurality of outwardly extending stops, tabs or teeth 542m22'. The stops 542m22' engage the female structural element 514f1' in a one-way slide and lock articulating motion.

[0288] The male stops 542m12' are configured so that they have generally flat end surfaces 550m22' to substantially reduce or minimize recoil and generally tapered engaging surfaces 552m22' to facilitate one-way sliding (see, for example, FIGS. 31 and 33).

Other suitable configurations that inhibit undesirable recoil and facilitate one-way expansion may be efficaciously utilized, as needed or desired.

[0289] In one embodiment, one or both of the male ribs **536m22'** include one or more inwardly extending stops, tabs or teeth **542m22i'** (see, for example, **FIG. 34**). These stops **542m22i'** are configured to allow only one-way sliding and provide a mechanism to substantially reduce or minimize recoil.

[0290] Each of the male ribs **536m22'** also includes an outwardly extending end stop, tab, wing or tooth **542m22e'**. The end stops **542m22e'** engage a capture mechanism of the female structural element **514f1'** to control and limit the maximum stent expansion.

[0291] The end stops **542m22e'** have generally flat engaging surfaces **552m22e'** that facilitate lock-out and capture at full expansion (see, for example, **FIGS. 31** and **33**). Other suitable lock-out and capture configurations may be efficaciously utilized, as needed or desired.

[0292] The female structural elements **514f1'** and **514f2'** are of generally similar construction as are the other female structural elements of the stent **510**. Thus, for brevity, the female structural element **514m1'** is discussed in greater detail below with respect to articulation, lock-out and capture features. It is to be understood that a generally similar arrangement is encompassed by the other male structural elements **514m** of the stent **510**.

[0293] The end portion **528f11'** of the female structural element **514f1'** slidingly articulates with the male rib **536m11'** as generally denoted by arrows **518**. The end portion **528f11'** also advantageously provides an internal protected locking mechanism for rib articulation and capture of the rib **536m11'** at full stent expansion.

[0294] The end portion **528f11'** includes a pair of spaced deflectable elements, fingers, stops or tabs **531f11'**. During expansion, the deflectable elements **531f11'** and the respective stops **542m11'** cross one another. This is accomplished by utilizing an axially deflecting mechanism.

[0295] Thus, during "cross-over" the deflectable elements **531f11'** are deflected outwards and then resume their original undeflected position. This axial, longitudinal or lateral motion is generally denoted by arrows **544**. The axial deflection is caused by the

generation of a generally axial or longitudinal force when the deflectable elements **531f11'** and respective male stops **542m11'** slide over, engage or abut one another.

[0296] A lock-out and capture mechanism includes one or more spaced end stops, tabs or teeth **532f11e'** that engage respective end hard stops **542m11e'** of the male rib **536m11'** at full stent expansion, and prevent further expansion. This provides to control and limit stent expansion to a predetermined deployment diameter.

[0297] A raised capture strap or device **554f11'** and an associated slot, gap or recess **556f11'** can be provided proximate to the hard stops **532f11e'**. The capture strap **554f11'** can serve to protect and/or align the male rib **536m11'** and the articulating and lock-out mechanisms, and also prevent the male rib **536m11'** from jumping out of its track. The internal protected articulating and locking mechanisms advantageously allow clearance space at the outer stent periphery which shields and protects the mechanisms from external surface interferences.

[0298] The slot **556f11'** extends between the end hard stops **532f11e'** and allows passage of the male rib articulating stops **542m11'** but prevents the male rib end hard stops **542m11e'** to pass through, thereby desirably providing a lock-out and capture mechanism. The slot **556f11'** can also provide protection, clearance space and/or alignment of the male rib **536m11'** and its engaging mechanisms, and also prevent the male rib **536m11'** from jumping out of its track.

[0299] In some embodiments, the end portion **528f11'** includes a shielding and alignment strap, device or element **570f11'** (see, for example, **FIGS. 35** and **36**). The raised element **570f11'** provides protection, clearance space and/or alignment of the male rib **536m11'** and its engaging mechanisms, and also prevents the male rib **536m11'** from jumping out of its track.

[0300] The end portion **528f11'** can also include one or more spaced clearance elements, spaces, gaps or recesses **572f11'**. Advantageously, the raised portions of the elements **572f11'** provide protection, clearance space and/or alignment of the male ribs **536m22'** in particular during the collapsed and initial stages of stent expansion.

[0301] The end portion **528f12'** of the female structural element **514f1'** slidingly articulates with the male ribs **536m22'** as generally denoted by arrows **518**. The end portion

528f12' also advantageously provides an internal protected locking mechanism for rib articulation and capture of the ribs 536m22' at full stent expansion.

[0302] The end portion 528f12' includes a pair of spaced deflectable elements, fingers, stops or tabs 531f12'. During expansion, the deflectable elements 531f12' and the respective stops 542m22' cross one another. This is accomplished by utilizing an axially deflecting mechanism.

[0303] Thus, during "cross-over" the deflectable elements 531f12' are deflected outwards and then resume their original undeflected position. This axial, longitudinal or lateral motion is generally denoted by arrows 544. The axial deflection is caused by the generation of a generally axial or longitudinal force when the deflectable elements 531f12' and respective male stops 542m22' slide over, engage or abut one another.

[0304] A lock-out and capture mechanism includes one or more spaced end stops, tabs or teeth 532f12e' that engage respective end hard stops 542m22e' of the male ribs 536m22' at full stent expansion, and prevent further expansion. This provides to control and limit stent expansion to a predetermined deployment diameter.

[0305] A pair of raised capture straps or devices 554f12' and associated slots, gaps or recesses 556f12' can be provided proximate to respective hard stops 532f12e'. The capture straps 554f12' can serve to protect and/or align respective male ribs 536m22' and the articulating and lock-out mechanisms, and also prevent the male ribs 536m22' from jumping out of their track. The internal protected articulating and locking mechanisms advantageously allow clearance space at the outer stent periphery which shields and protects the mechanisms from external surface interferences.

[0306] The slots 556f12' extend between the end hard stops 532f12e' and allow passage of respective male rib articulating stops 542m22' but prevent the male rib end hard stops 542m22e' to pass through, thereby desirably providing a lock-out and capture mechanism. The slots 556f12' can also provide protection, clearance space and/or alignment of respective female ribs 536f22' and their engaging mechanisms, and also prevent the male ribs 536m22' from jumping out of their track.

[0307] In some embodiments, the end portion 528f12' includes a shielding and alignment strap, device or element 570f12' (see, for example, FIGS. 35 and 36). The raised

element **570f12'** is configured to provide protection, clearance space and/or alignment of the female ribs **536f22'** and their engaging mechanisms. The raised element **57f12'** is also shaped to provide additional stent strength and facilitate a curved structure when the stent **510** is coiled or rolled down. The shape logic of the device **570f12'** is to provide a capture element configuration and structural support for the "box" shape and/or to provide stiffness and support to the center section.

[0308] The end portion **528f12'** can also include a clearance element, space, gap or recess **572f12'**. Advantageously, the raised portion of the element **572f12'** provides protection, clearance space and/or alignment of the male rib **536m11'** in particular during the collapsed and initial stages of stent expansion.

[0309] Referring in particular to **FIG. 30**, in one embodiment, the undeployed length $L_{undeployed}$ is about 5.1 mm (0.2 inches) and the undeployed stent diameter is about 1.6 mm (0.064 inches). In other embodiments, the undeployed lengths and undeployed diameters may efficaciously be higher or lower, as needed or desired.

[0310] Referring in particular to **FIG. 32**, in one embodiment, the deployed length $L_{deployed}$ is about 10.6 mm (0.419 inches) and the deployed stent diameter is about 3.4 mm (0.133 inches). In other embodiments, the deployed lengths and deployed diameters may efficaciously be higher or lower, as needed or desired.

[0311] **FIG. 38** shows the expandable stent **510** during a phase of its fabrication and assembly. In some embodiments, the stent **510** is formed using a lamination and laser cutting process to yield the structure as shown in **FIG. 38**. The stent **510** is then rolled into a tubular shape in the collapsed state.

[0312] In some embodiments, axially extending rows **513f1**, **513m1**, **513f2**, **513m2** can each be formed as an integral unit and then connected and rolled into a tubular form in the collapsed state. This may be accomplished by using an injection molding technique or the like, among others. The row **513f1** comprises female structural elements **514f1** connected by linkage elements **522f1**, the row **513m1** comprises male structural elements **514m1** connected by linkage elements **522m1**, the row **513f2** comprises female structural elements **514f2** connected by linkage elements **522f2** and the row **513m2** comprises male structural elements **514m2** connected by linkage elements **522m2**.

Some Further Stent Embodiments

[0313] FIGS. 39-42 show views of an expandable axially nested slide and lock vascular device, prosthesis or stent **610** including deployed and undeployed states. In a rolled configuration, the stent **610** has a tubular form with a wall comprising a plurality of generally longitudinally arranged linked circumferential sections, segments or frames **612a**, **612s**. The stent **610** is expandable from a first diameter to a second diameter.

[0314] Advantageously, the axially nested embodiments of the stent **610** allow suitable crossing profiles (e.g. luminal size) while maintaining desirable radial strength and luminal patency. In the non-expanded state, there is also minimal or reduced overlap between structural elements, so that the luminal size facilitates insertion of a guiding catheter balloon or the like to expand the vascular device.

[0315] The stent **610** comprises alternately arranged slide and lock sections **612a** and linkage sections **612s**. Each section **612a** includes three structural elements **614mf1**, **614mf2**, **614mf3** that each slidingly mate with one another via respective interlocking articulating mechanisms **616mf1**, **616mf2**, **616mf3**. (Each of the structural elements **614** may also be described as comprising two structural elements – one male and one female - since each mates at two circumferential locations.)

[0316] Each linkage section **612s** includes three elements **622mf1**, **622mf2**, **622mf3**. The linkage elements **622mf1** connect structural elements **614mf1** to form a stent element row **613mf1**. The linkage elements **622mf2** connect structural elements **614mf2** to form a stent element row **613mf2**. The linkage elements **622mf3** connect structural elements **614mf3** to form a stent element row **613mf3**. The number of elements in a section or row and the number of sections and rows in a stent may be efficaciously varied and selected, as needed or desired.

[0317] One or more of the linkage elements **622** may comprise spring elements. The spring elements **622** provide flexibility and allow expansion of the linkage sections **612s** along with stent expansion. The spring elements **622** also allow for radial and/or axial element or member deflection during stent expansion to a deployed state. The spring

elements **622** facilitate this deflection by providing a resilient biasing mechanism to achieve substantially elastic deflection or deformation.

[0318] The linkage elements **622mf1** axially or longitudinally connect the structural elements **614mf1**. In one embodiment, the linkage elements **622mf1** and the structural elements **614mf1** comprise an integral unit, that is, the stent row **613mf1** comprises an integral unit. In modified embodiments, the linkage elements **622mf1** and the structural elements **614mf1** can efficaciously be connected by other techniques, as needed or desired.

[0319] The linkage elements **622mf2** axially or longitudinally connect the structural elements **614mf2**. In one embodiment, the linkage elements **622mf2** and the structural elements **614mf2** comprise an integral unit, that is, the stent row **613mf2** comprises an integral unit. In modified embodiments, the linkage elements **622mf2** and the structural elements **614mf2** can efficaciously be connected by other techniques, as needed or desired.

[0320] The linkage elements **622mf3** axially or longitudinally connect the structural elements **614mf3**. In one embodiment, the linkage elements **622mf3** and the structural elements **614mf3** comprise an integral unit, that is, the stent row **613mf3** comprises an integral unit. In modified embodiments, the linkage elements **622mf3** and the structural elements **614mf3** can efficaciously be connected by other techniques, as needed or desired.

[0321] In some embodiments, each of the axially extending rows **613mf1**, **613mf2**, **613mf3** are first formed as independent units that may be independent integral units. The stent rows **613mf1**, **613mf2**, **613mf3** are then connected and rolled into a tubular form in the collapsed state.

[0322] The axial or longitudinal coupling between the structural elements **614** of adjacent sections **612a**, the radial coupling between structural elements **614** of the same section **612a**, and the design and configuration of the sections **612** and structural elements **614** are such that there is minimal or reduced overlapping in the radial or circumferential direction between the structural elements **614** in both the non-expanded and expanded states. Thus, the structural elements **614**, sections **612** and/or stent **610** are referred to as being axially, longitudinally or non-radially nested. (There is also minimal or reduced radial overlap between linkage elements **622** of the same and adjacent sections **612s** in both the undeployed and deployed states.)

[0323] During stent expansion, there is circumferential relative motion between the mating structural elements **614mf1**, **614mf2**, **614mf3** as generally shown by arrows **518**. One or more or all of structural elements **614mf1**, **614mf2**, **614mf3** in any suitable combination may slidably move apart.

[0324] The structural element **614mf1** generally comprises female portion with a pair spaced of ribs or arms **626f1** and a male portion with a pair of spaced ribs or arms **636m12** terminating in a single rib or arm **636m11**. The end structural elements **614mf1** may comprises side extensions or supports **622mf1e**. As discussed above and below herein, the structural element **614mf1** has one or more slide and lock articulating mechanisms such as tongue-groove configuration stops, tabs or teeth that engage respective coupled structural elements **614mf2**, **614mf3** to provide radially deflecting mechanisms for stent expansion and lock-out.

[0325] The female ribs **626f1** are spaced by an end portion **628f1**. Each of the ribs **626f1** includes a cavity **674f1** in which a plurality of radially deflectable elements, stops, tabs or teeth **632f1** extend. Each of the ribs **626f1** further includes slots **654f1** that receive a mating portion from the adjacent structural element **614mf2**. Each of the slots **654f1** terminates at the end portion **628f1** at a respective one of end hard stops **632f1e** that control and limit the maximum stent expansion to a predetermined diameter.

[0326] The deflectable elements **632f1** engage the male portion of the radially coupled structural element **614mf2** in a one-way slide and lock articulating motion. The deflectable elements **632f1** are configured so that they have generally flat end surfaces **646f1** to substantially reduce or minimize recoil and generally tapered engaging surfaces **648f1** to facilitate one-way sliding (see, for example, **FIG. 42**). Other suitable configurations that inhibit undesirable recoil and facilitate one-way expansion may be efficaciously utilized, as needed or desired.

[0327] The male portion of the structural element **614mf1** has a generally central portion **638m1** that connects the ribs **636m12** and the rib **636m11**. As discussed further below, the central portion **638m1** serves as a hard stop in the stent collapsed state.

[0328] Each of the ribs **636m12** includes a slot **654m12** that receives a mating portion from the adjacent structural element **614mf2**. Each of the slots **654m12** is connected

to or is in communication with at least one of the respective female portion slots **654f1**. The male rib **636m11** may also include a slot **654m11** that is connected to or is in communication with the slots **654m12**.

[0329] The male rib **636m11** includes a pair of outwardly extending end stops, tabs, wings or teeth **642m11e** with one each extending on each sides of the rib **636m11**. The stops **642m11e** engage the female portion of the adjacent structural element **614mf3** in a one-way slide and lock articulating motion. The stops **642m11e** are configured so that they have generally flat end surfaces **650m11e** to substantially reduce or minimize recoil. Other suitable configurations that inhibit undesirable recoil may be efficaciously utilized, as needed or desired.

[0330] As discussed further below, the end stops **642m11e** engage a capture mechanism of a mating structural element to control and limit the maximum stent expansion. The end stops **642m11e** are configured to have generally flat engaging surfaces **652m11e** that facilitate lock-out and capture at full expansion while allowing one-way slide and lock motion during expansion. Other suitable lock-out and capture configurations may be efficaciously utilized, as needed or desired.

[0331] The end wings **642m11e** are spaced by a generally central raised portion **642m11c**. As discussed further below, the central portion **642m11c** serves as a hard stop in the stent collapsed state.

[0332] The end stops **642m11e** have generally flat engaging surfaces **652m11e** that facilitate lock-out and capture at full expansion (see, for example, **FIG. 42**). Other suitable lock-out and capture configurations may be efficaciously utilized, as needed or desired.

[0333] The structural elements **614mf1**, **614mf2**, **614mf3** are of generally similar construction. Thus, for brevity, the features of the structural element **614mf1** have been discussed in greater detail with respect to articulation, lock-out and capture features. It is to be understood that a generally similar arrangement is encompassed by the other structural elements **614mf2** and **614mf3** of the stent **610**, and similar reference numerals are used herein.

[0334] Thus, for example, if the female ribs of the structural element **614mf1** are denoted by **626f1**, then the female ribs of the structural elements **614mf2** and **614mf3** are respectively denoted by **626f2** and **626f3**, and so on. Similarly, if the male rib of the structural element **614mf1** is denoted by **636m11**, then the male ribs of the structural elements **614mf2** and **614mf3** are respectively denoted by **636m21** and **636m31**, and so on.

[0335] Advantageously, there is substantially no or minimal overlap between nesting structural elements **614mf1**, **614mf2** and **614mf3** in both the collapsed state and the expanded state, and more particularly in the expanded state. Thus, the stent **610**, its sections **612a** and/or structural elements **614** are referred to as being axially nested.

[0336] Embodiments of the invention provide an axially nested vascular device **610** to achieve both competitive crossing profiles (e.g. luminal size) while maintaining other key features, such as, for example, radial strength and luminal patency. Advantageously, an axially nested device design allows for use of thicker materials to maintain radial strength, as needed or desired.

[0337] During manufacture and assembly of the axially nested embodiments, the device structural elements (e.g., **614mf1**, **614mf2**) and/or ribs (e.g. the female ribs **626m1** and the male ribs **636m12**) are positioned side by side (axially) in the predilated or non-expanded state to substantially reduce or minimize the device crossing profile and bulk in both the undeployed (non-expanded, predilated) and deployed (expanded, dilated) states. Advantageously, by substantially reducing or eliminating the excess bulk typically encountered with a radially nesting device design, embodiments of the invention can be used to achieve competitive devices and crossing profiles with a wide variety of materials at a wide variety of thicknesses, thereby desirably allowing for optimum device design and performance.

[0338] The articulation between the structural elements **614mf1** and **614mf2** of a given stent section **612a** is discussed below. As the skilled artisan will recognize, a similar articulation is applicable to other mating structural elements of the stent **610**. Thus, for brevity it is not repeated herein.

[0339] In the collapsed state (**FIG. 39**), the male portion of the structural element **614mf2** mates with the structural element **614mf1**. More specifically, the male rib **636m21**

extends into the gap between the ribs **636m12**, the wings **642m21e** extend into respective slots **654m12** and the raised hard stop **642m21c** abuts against the raised portion **638m1**. Advantageously, in the collapsed state, there is axial nesting between the mating structural elements **614mf1** and **614mf2** at least in part because the respective ribs **636m12** and **636m21** are axially or longitudinally displaced or offset from one another.

[0340] In the collapsed state, the male ribs **636m22** extend into the gap between the female ribs **626f1**. Again advantageously, in the collapsed state, there is axial nesting between the mating structural elements **614mf1** and **614mf2** at least in part because the female ribs **626f1** and male ribs **636m22** are axially or longitudinally displaced or offset from one another.

[0341] During stent expansion, there is circumferential relative motion between male ribs **636m21**, **636m22** of the structural element **614mf2** and the ribs **636m12**, **626f1** of the structural element **614mf1** as generally indicated by arrows **618**. The male ribs **636m21** withdraw from the gap between the ribs **636m12** and the male ribs **636m22** withdraw from the gap between the ribs **626f1**. The wings **642m21e** slide within respective slots **654m11** such that their relative motion is towards the female ribs **626f1**.

[0342] As the rib **636m21** begins to extend out of the gap between the ribs **636m12** and into the gap between the ribs **626f1**, and the ribs **636m22** begin to extend out of the gap between the ribs **626f1**, the wings **642m21e** slide into respective slots **654f1** and cavities **674f1**. The wings **642m21e** engage the respective deflectable elements, fingers, stops or tabs **632f1**. Thus, during expansion, the deflectable elements **632f1** and the respective wings **642m21e** cross one another. This is accomplished by utilizing a generally radially deflecting mechanism.

[0343] Thus, during "cross-over" the deflectable elements **632f1** are deflected radially inwards and then resume their original undeflected position. This radial motion is generally denoted by arrows **644**. The radial deflection is caused by the generation of a generally radial force when the deflectable elements **632f1** and respective wings **642m21e** slide over, engage or abut one another.

[0344] The tapered surfaces **648f1** of the deflectable elements **632f1** facilitate sliding in one direction. The generally flat end surfaces **646f1** of the deflectable elements

632f1 and the generally flat end surfaces of the wings 650m21e desirably substantially reduce or minimize recoil.

[0345] At full expansion, the hard stops 652m21e of the wings 642m21e and the respective end hard stops 632f1e of the structural element portion 628f1 contact, engage or abut against one other, and prevent further stent expansion. This lock-out and capture mechanism provides to control and limit stent expansion to a predetermined deployment diameter.

[0346] The internal protected articulating and locking mechanisms of the stent 610 advantageously allow clearance space at the outer stent periphery which shields and protects the mechanisms from external surface interferences. Raised and recessed portions of the structural elements 614mf provide this shielding, for example, the top portions of the female ribs 626f1. The structural elements 614mf are also configured to facilitate alignment between the mating elements.

Still Further Stent Embodiments

[0347] FIGS. 43 and 44 show views of expandable axially nested slide and lock vascular devices, prostheses or stents 710 (710' and 710"). FIG. 45 shows an enlarged view of an articulating and lock-out mechanism 716mf1 of the stent 710".

[0348] In a rolled configuration, the stent 710 has a tubular form with a wall comprising a plurality of generally longitudinally arranged linked circumferential sections, segments or frames 712a, 712s. The stent 710 is expandable from a first diameter to a second diameter. (The axially nested stents 710' and 710" are generally similar in overall design but their articulating and lock-out mechanisms have different constructions, as discussed further below, in accordance with embodiments of the invention.)

[0349] Advantageously, the axially nested embodiments of the stent 710 allow suitable crossing profiles (e.g. luminal size) while maintaining desirable radial strength and luminal patency. In the non-expanded state, there is also minimal or reduced overlap between structural elements, so that the luminal size facilitates insertion of a guiding catheter balloon or the like to expand the vascular device.

[0350] The stent 710 comprises alternately arranged slide and lock sections 712a and linkage sections 712s. Each section 712a includes a pair of female structural elements 714f1, 714f2 and a pair of male structural elements 714m1, 714m2 that each slidingly mate with the female structural elements 714f1, 714f2 via respective interlocking articulating mechanisms 716mf1, 716mf2. (Each of the structural elements 714 may also be described as comprising two structural elements since each mates at two circumferential locations.)

[0351] As described further below, the articulating mechanisms 716 comprise substantially axially (laterally) deflecting locking mechanisms. The number of structural elements in a section and/or the number of sections in a stent may be efficaciously varied and selected, as needed or desired.

[0352] The axial or longitudinal coupling between the structural elements 714 of adjacent sections 712a, the radial coupling between structural elements 714 of the same section 712a, and the design and configuration of the sections 712 and structural elements 714 are such that there is minimal or reduced overlapping in the radial or circumferential direction between the structural elements 714 in both the non-expanded and expanded states. Thus, the structural elements 714, sections 712 and/or stent 710 are referred to as being axially, longitudinally or non-radially nested. (There is also minimal or reduced radial overlap between linkage elements 722 of the same and adjacent sections 712s in both the undeployed and deployed states.)

[0353] Each of the stent linkage sections 712s generally comprises linkage elements 722m1, 722f1, 722m2, 722f2 which are connected to respective structural elements 714m1, 714f1, 714m2, 714f2. Stent row 713m1 generally comprises the elements 714m1 and 722m1, row 713f1 generally comprises the elements 714f1 and 722f1, row 713m2 generally comprises the elements 714m2 and 722m2, and row 713f2 generally comprises the elements 714f2 and 722f2.

[0354] The female structural element 714f1 generally comprises a generally central rib, arm or portion 726f1 spaced from a pair of side ribs or arms 726f11, 726f12. End portions 728f11, 728f12 connect the ribs 726f1, 726f11, 726f12. As discussed above and below herein, the female structural element 714f1 and one or more of its ribs 726f1, 726f11,

726f22 have slide and lock articulating mechanisms such as tongue-groove configuration stops, tabs, wings or teeth that engage male structural elements 714m1, 714m2 to provide axially deflecting mechanisms for stent expansion and lock-out.

[0355] The female structural element 714f2 generally comprises a generally central rib, arm or portion 726f2 spaced from a pair of side ribs or arms 726f21, 726f22. End portions 728f21, 728f22 connect the ribs 726f2, 726f21, 726f22. As discussed above and below herein, the female structural element 714f2 and one or more of its ribs 726f2, 726f21, 726f22 have slide and lock articulating mechanisms such as tongue-groove configuration stops, tabs, wings or teeth that engage female structural elements 714f1, 714f2 to provide axially deflecting mechanisms for stent expansion and lock-out.

[0356] The male structural element 714m1 generally comprises a first rib or arm 736m11 and a second rib or arm 736m12 extending in opposite directions. The ribs 736m11, 736m12 share a share a common end portion 738m1. In the stent collapsed state, the male rib 736m11 extends in the gap between and/or is engaged with the female ribs 726f1, 726f11 and the male rib 736m12 extends in the gap between and/or is engaged with the female ribs 726f2, 726f22. As discussed above and below herein, the ribs 736m11, 736m12 have slide and lock articulating mechanisms such as tongue-groove configuration stops, tabs, wings or teeth that engage respective female structural elements 714f1, 714f2 to provide axially deflecting mechanisms for stent expansion and lock-out.

[0357] The male structural element 714m2 generally comprises a first rib or arm 736m21 and a second rib or arm 736m22 extending in opposite directions. The ribs 736m21, 736m22 share a share a common end portion 738m2. In the stent collapsed state, the male rib 736m21 extends in the gap between and/or is engaged with the female ribs 726f1, 726f12 and the male rib 736m22 extends in the gap between and/or is engaged with the female ribs 726f2, 726f21. As discussed above and below herein, the ribs 736m21, 736m22 have slide and lock articulating mechanisms such as tongue-groove configuration stops, tabs, wings or teeth that engage respective female structural elements 714f1, 714f2 to provide axially deflecting mechanisms for stent expansion and lock-out.

[0358] Each linkage section 712s includes a plurality of the elements 722 (722m1, 722f1, 722m2, 722f2) and connects adjacent stent sections 712a. One or more of

the linkage elements 722 may comprise spring elements. In the embodiment of FIGS. 43 and 44, the spring elements 722 provide device flexibility and can allow expansion of the linkage sections 712s along with stent expansion.

[0359] The linkage elements 722m1 axially or longitudinally connect the male structural elements 714m1. In one embodiment, the linkage elements 722m1 and the male structural elements 714m1 comprise an integral unit, that is, the stent row 713m1 comprises an integral unit. In modified embodiments, the linkage elements 722m1 and the male structural elements 714m1 can efficaciously be connected by other techniques, as needed or desired.

[0360] The linkage elements 722m2 axially or longitudinally connect the male structural elements 714m2. In one embodiment, the linkage elements 722m2 and the male structural elements 714m2 comprise an integral unit, that is, the stent row 713m2 comprises an integral unit. In modified embodiments, the linkage elements 722m2 and the male structural elements 714m2 can efficaciously be connected by other techniques, as needed or desired.

[0361] The linkage elements 722f1 axially or longitudinally connect the female structural elements 714f1. In one embodiment, the linkage elements 722f1 and the female structural elements 714f1 comprise an integral unit, that is, the stent row 713f1 comprises an integral unit. In modified embodiments, the linkage elements 722f1 and the female structural elements 714f1 can efficaciously be connected by other techniques, as needed or desired.

[0362] The linkage elements 722f2 axially or longitudinally connect the female structural elements 714f2. In one embodiment, the linkage elements 722f2 and the female structural elements 714f2 comprise an integral unit, that is, the stent row 713f2 comprises an integral unit. In modified embodiments, the linkage elements 722f2 and the female structural elements 714f2 can efficaciously be connected by other techniques, as needed or desired.

[0363] During stent expansion, there is circumferential relative motion between the mating male structural elements 714m1, 714m2 and female structural elements 714f1, 714f2 as generally shown by arrows 718. One or both of the male structural elements 714m1, 714m2, one or both of the female structural elements 714f1, 714f2, both the male

and female structural elements **714m1**, **714m2**, **714f1**, **714f2**, or any suitable combination thereof may slidably move apart to achieve the desired or predetermined expansion.

[0364] More specifically, during expansion, there is circumferential relative motion between: the female ribs **726f1**, **726f11** and the male rib **736m11** with one or both slidably moving apart; the female ribs **726f1**, **726f12** and the male rib **736m21** with one or both slidably moving apart; the female ribs **726f2**, **726f21** and the male rib **736m22** with one or both slidably moving apart; and the female ribs **726f2**, **726f22** and the male rib **736m12** with one or both slidably moving apart. The motion is generally denoted by arrows **718**.

[0365] As discussed herein, at full expansion, a capture mechanism is provided to limit further stent expansion to a predetermined deployment diameter. Each section **712a** and/or structural element **714** can comprise one or more capture mechanisms such as straps, hard stops, and the like among other suitable devices that prevent further expansion between mating male and female structural elements **714m** and **714f** and control the maximum expansion. Any of the capture mechanisms as disclosed, taught or suggested herein may efficaciously be used in conjunction with the stent **710** and any of the other stent embodiments, as needed or desired.

[0366] Advantageously, there is substantially no or minimal overlap between nesting male structural elements **714m** and associated female structural elements **714f** in both the collapsed state and the expanded state, and more particularly in the expanded state. For example, for a given stent section **712a**, in the collapsed state the female ribs **726f1**, **726f11**, **726f12** and the male ribs **736m11**, **736m21** are substantially axially or longitudinally displaced or offset while in the expanded state the same are substantially radially or circumferentially displaced or offset, thereby minimizing radial overlap in both the collapsed and expanded states. Thus, the stent **710**, its sections **712** and/or structural elements **714** are referred to as being axially nested since their radial overlap is substantially reduced or minimal in both the collapsed and expanded states.

[0367] Embodiments of the invention provide an axially nested vascular device **710** to achieve both competitive crossing profiles (e.g. luminal size) while maintaining other key features, such as, for example, radial strength and luminal patency. Advantageously, an

axially nested device design allows for use of thicker materials to maintain radial strength, as needed or desired.

[0368] During manufacture and assembly of the axially nested embodiments, the device structural elements (e.g., 714m, 714f) and/or ribs (e.g. the female ribs 726f1, 726f11, 726f12 and the male ribs 736m11, 736m21) are positioned side by side (axially) in the predilated or non-expanded state to substantially reduce or minimize the device crossing profile and bulk in both the undeployed (non-expanded, predilated) and deployed (expanded, dilated) states. Advantageously, by substantially reducing or eliminating the excess bulk typically encountered with a radially nesting device design, embodiments of the invention can be used to achieve competitive devices and crossing profiles with a wide variety of materials at a wide variety of thicknesses, thereby desirably allowing for optimum device design and performance.

[0369] The articulation between the structural elements 714m1 and 714f1 of a given stent section 712a is discussed below. As the skilled artisan will recognize, a similar articulation is applicable to other mating structural elements and/or ribs of the stent 710. Thus, for brevity it is not repeated herein.

[0370] Referring in particular to FIG. 43, that is the stent 710', the male rib 736m11 includes a pair of outwardly extending deflectable elements, stops, tabs, wings or teeth 742m' with one each extending on each side of the rib 736m11. The stops 742m' engage respective stops, tabs or teeth 732f' of the female ribs 726f1, 726f11 in a one-way slide and lock articulating motion. This is accomplished by utilizing a generally axial deflecting mechanism.

[0371] Thus, during "cross-over" the deflectable wings 742m' are deflected axially inwards and then resume their original undeflected position. This axial motion is generally denoted by arrows 744. The axial deflection is caused by the generation of a generally axial force when the deflectable wings 742m' and respective teeth 732f' slide over, engage or abut one another.

[0372] The stops 742m', 732f' are configured to facilitate one-way sliding relative motion as generally shown by arrows 718. The stops 742m', 732f' are also configured to substantially reduce or minimize recoil. Other suitable configurations that

inhibit facilitate one-way motion and undesirable recoil may be efficaciously utilized, as needed or desired.

[0373] At full expansion, a hard stop **742me'** of the male rib **736m11** and a safety hard stop **732fe'** of the structural element portion **728f11** contact, engage or abut against one other, and prevent further stent expansion. This lock-out and capture mechanism provides to control and limit stent expansion to a predetermined deployment diameter. The safety stop **742me'** also prevents the male rib **736m11** from jumping off the female ribs **726f1**, **726f11** during deployment and keeps the rib **736m11** in its appropriate track.

[0374] Referring in particular to **FIGS. 44** and **45**, that is the stent **710"**, the male rib **736m11** includes a pair of outwardly extending deflectable elements, stops, tabs, wings or teeth **742m"** with one each extending on each side of the rib **736m11**. In the collapsed state, the wings **742m"** are positioned in a cavity **774f"** between the female ribs **726f1**, **726f11**.

[0375] During stent expansion, the wings **742m"** engage respective internal stops, tabs or teeth **732f"** of the female ribs **726f1**, **726f11** in a one-way slide and lock articulating motion. This is accomplished by utilizing a generally axial deflecting mechanism.

[0376] Thus, during "cross-over" the deflectable wings **742m"** are deflected axially inwards and then resume their original undeflected position. This axial motion is generally denoted by arrows **744**. The axial deflection is caused by the generation of a generally axial force when the deflectable wings **742m"** and respective teeth **732f"** slide over, engage or abut one another.

[0377] The stops **742m"**, **732f"** are configured to facilitate one-way sliding relative motion as generally shown by arrows **718**. The stops **742m"**, **732f"** are also configured to substantially reduce or minimize recoil. Other suitable configurations that inhibit facilitate one-way motion and undesirable recoil may be efficaciously utilized, as needed or desired.

[0378] The teeth **732f"** are positioned within respective slots **754f"** and under respective raised or top portions **756f"** of respective female ribs **726f1**, **726f11**. Thus, the wings **742m"** also extend into the slots **754f"**. Advantageously, the top portions **756f"** prevents the male rib **736m11** from jumping off the female ribs **726f1**, **726f11** during deployment and keeps the rib **736m11** in its appropriate track.

[0379] At full expansion, one or more hard stops 732fe” of the structural element portion 728f11 contact, engage or abut against the wings 742m”, and prevent further stent expansion. This lock-out and capture mechanism provides to control and limit stent expansion to a predetermined deployment diameter.

[0380] FIG. 46 shows a die 776 that is used to fabricate the stent rows 713f1, 713f2 in accordance with one embodiment. An injection molding process or the like, among others, may be used to form stent rows 713f1, 713f2 as integral units. The stent rows 713m1, 713m2 can also be similarly formed as integral units. The axially extending rows 713f1, 713m1, 713f2, 713m2 can then be connected and rolled into a tubular form in the collapsed state.

Yet Further Stent Embodiments

[0381] FIGS. 47 and 48 show views of expandable axially nested slide and lock vascular devices, prostheses or stents 810 (810’ and 810”). In a rolled configuration, the stent 810 has a tubular form with a wall comprising a plurality of generally longitudinally arranged linked circumferential sections, segments or frames 812a, 812s. The stent 810 is expandable from a first diameter to a second diameter. (The axially nested stents 810’ and 810” are generally similar in overall design but their articulating and lock-out mechanisms may have slightly different constructions, as shown in the drawings, in accordance with embodiments of the invention.)

[0382] Advantageously, the axially nested embodiments of the stent 810 allow suitable crossing profiles (e.g. luminal size) while maintaining desirable radial strength and luminal patency. In the non-expanded state, there is also minimal or reduced overlap between structural elements, so that the luminal size facilitates insertion of a guiding catheter balloon or the like to expand the vascular device.

[0383] The stent 810 comprises alternately arranged slide and lock sections 812a and linkage sections 812s. Each section 812a includes a pair of male structural elements 814m1, 814m2 and a pair of female structural elements 814f1, 814f2 that each slidingly mate with the male structural elements 814m1, 814m2 via respective interlocking articulating mechanisms 816mf1, 816mf2. (Each of the structural elements 814 may also be

described as comprising two structural elements since each mates at two circumferential locations.)

[0384] As described further below, the articulating mechanisms **816** comprise substantially radially deflecting locking mechanisms. The number of structural elements in a section and/or the number of sections in a stent may be efficaciously varied and selected, as needed or desired.

[0385] The axial or longitudinal coupling between the structural elements **814** of adjacent sections **812a**, the radial coupling between structural elements **814** of the same section **812a**, and the design and configuration of the sections **812** and structural elements **814** are such that there is minimal or reduced overlapping in the radial or circumferential direction between the structural elements **814** in both the non-expanded and expanded states. Thus, the structural elements **814**, sections **812** and/or stent **810** are referred to as being axially, longitudinally or non-radially nested. (There is also minimal or reduced radial overlap between linkage elements **822** of the same and adjacent sections **812s** in both the undeployed and deployed states.)

[0386] Each of the stent linkage sections **812s** generally comprises linkage elements **822m1**, **822f1**, **822m2**, **822f2** which are connected to respective structural elements **814m1**, **814f1**, **814m2**, **814f2**. Stent row **813m1** generally comprises the elements **814m1** and **822m1**, row **813f1** generally comprises the elements **814f1** and **822f1**, row **813m2** generally comprises the elements **814m2** and **822m2**, and row **813f2** generally comprises the elements **814f2** and **822f2**.

[0387] The female structural element **814f1** generally comprises a generally central rib, arm or portion **826f1** spaced from a pair of side ribs or arms **826f11**, **826f12**. End portions **828f11**, **828f12** connect the ribs **826f1**, **826f11**, **826f12**. As discussed above and below herein, the female structural element **814f1** and one or more of its ribs **826m1**, **826m11**, **826m22** have slide and lock articulating mechanisms such as tongue-groove configuration stops, tabs, wings or teeth that engage male structural elements **814m1**, **814m2** to provide radially deflecting mechanisms for stent expansion and lock-out.

[0388] The female structural element **814f2** generally comprises a generally central rib, arm or portion **826f2** spaced from a pair of side ribs or arms **826f21**, **826f22**. End

portions **828f21**, **828f22** connect the ribs **826f2**, **826f21**, **826f22**. As discussed above and below herein, the female structural element **814f2** and one or more of its ribs **826f2**, **826f21**, **826f22** have slide and lock articulating mechanisms such as tongue-groove configuration stops, tabs, wings or teeth that engage male structural elements **814m1**, **814m2** to provide radially deflecting mechanisms for stent expansion and lock-out.

[0389] The male structural element **814m1** generally comprises a first rib or arm **836m11** and a second rib or arm **836m12** extending in opposite directions. The ribs **836m11**, **836m12** share a share a common end portion **838m1**. In the stent collapsed state, the male rib **836m11** extends in the gap between and/or is engaged with the female ribs **826f1**, **826f11** and the male rib **836m12** extends in the gap between and/or is engaged with the female ribs **826f2**, **826f22**. As discussed above and below herein, the ribs **836f11**, **836f12** have slide and lock articulating mechanisms such as tongue-groove configuration stops, tabs, wings or teeth that engage respective female structural elements **814f1**, **814f2** to provide radially deflecting mechanisms for stent expansion and lock-out.

[0390] The male structural element **814m2** generally comprises a first rib or arm **836m21** and a second rib or arm **836m22** extending in opposite directions. The ribs **836m21**, **836m22** share a share a common end portion **838m2**. In the stent collapsed state, the male rib **836m21** extends in the gap between and/or is engaged with the female ribs **826f1**, **826f12** and the male rib **836m22** extends in the gap between and/or is engaged with the female ribs **826f2**, **826f21**. As discussed above and below herein, the ribs **836m21**, **836m22** have slide and lock articulating mechanisms such as tongue-groove configuration stops, tabs, wings or teeth that engage respective female structural elements **814f1**, **814f2** to provide radially deflecting mechanisms for stent expansion and lock-out.

[0391] Each linkage section **812s** includes a plurality of the elements **822** (**822m1**, **822f1**, **822m2**, **822f2**) and connects adjacent stent sections **812a**. One or more of the linkage elements **822** may comprise spring elements. In the embodiments of FIGS. 47 and 48, the spring elements **822** provide device flexibility and can allow expansion of the linkage sections **812s** along with stent expansion.

[0392] The linkage elements **822m1** axially or longitudinally connect the male structural elements **814m1**. In one embodiment, the linkage elements **822m1** and the male

structural elements **814m1** comprise an integral unit, that is, the stent row **813m1** comprises an integral unit. In modified embodiments, the linkage elements **822m1** and the male structural elements **814m1** can efficaciously be connected by other techniques, as needed or desired.

[0393] The linkage elements **822m2** axially or longitudinally connect the male structural elements **814m2**. In one embodiment, the linkage elements **822m2** and the male structural elements **814m2** comprise an integral unit, that is, the stent row **813m2** comprises an integral unit. In modified embodiments, the linkage elements **822m2** and the male structural elements **814m2** can efficaciously be connected by other techniques, as needed or desired.

[0394] The linkage elements **822f1** axially or longitudinally connect the female structural elements **814f1**. In one embodiment, the linkage elements **822f1** and the female structural elements **814f1** comprise an integral unit, that is, the stent row **813f1** comprises an integral unit. In modified embodiments, the linkage elements **822f1** and the female structural elements **814f1** can efficaciously be connected by other techniques, as needed or desired.

[0395] The linkage elements **822f2** axially or longitudinally connect the female structural elements **814f2**. In one embodiment, the linkage elements **822f2** and the female structural elements **814f2** comprise an integral unit, that is, the stent row **813f2** comprises an integral unit. In modified embodiments, the linkage elements **822f2** and the female structural elements **814f2** can efficaciously be connected by other techniques, as needed or desired.

[0396] During stent expansion, there is circumferential relative motion between the mating male structural elements **814m1**, **814m2** and female structural elements **814f1**, **814f2** as generally shown by arrows **818**. One or both of the male structural elements **814m1**, **814m2**, one or both of the female structural elements **814f1**, **814f2**, both the male and female structural elements **714m1**, **714m2**, **714f1**, **714f2**, or any suitable combination thereof may slidably move apart to achieve the desired or predetermined expansion.

[0397] More specifically, during expansion, there is circumferential relative motion between: the female ribs **826f1**, **826f11** and the male rib **836m11** with one or both slidably moving apart; the female ribs **826f1**, **826f12** and the male rib **836m21** with one or both slidably moving apart; the female ribs **826f2**, **826f21** and the male rib **836m22** with one

or both slidably moving apart; and the female ribs **826f2**, **826f22** and the male rib **836m12** with one or both slidably moving apart. The motion is generally denoted by arrows **818**.

[0398] As discussed herein, at full expansion, a capture mechanism is provided to limit further stent expansion to a predetermined deployment diameter. Each section **812a** and/or structural element **814** can comprise one or more capture mechanisms such as straps, hard stops, and the like among other suitable devices that prevent further expansion between mating male and female structural elements **814m** and **814f** and control the maximum expansion. Any of the capture mechanisms as disclosed, taught or suggested herein may efficaciously be used in conjunction with the stent **810** and any of the other stent embodiments, as needed or desired.

[0399] Advantageously, there is substantially no or minimal overlap between nesting male structural elements **814m** and associated female structural elements **814f** in both the collapsed state and the expanded state, and more particularly in the expanded state. For example, for a given stent section **812a**, in the collapsed state the female ribs **826f1**, **826f11**, **826f12** and the male ribs **836m11**, **836m21** are substantially axially or longitudinally displaced or offset while in the expanded state the same are substantially radially or circumferentially displaced or offset, thereby minimizing radial overlap in both the collapsed and expanded states. Thus, the stent **810**, its sections **812** and/or structural elements **814** are referred to as being axially nested since their radial overlap is substantially reduced or minimal in both the collapsed and expanded states.

[0400] Embodiments of the invention provide an axially nested vascular device **810** to achieve both competitive crossing profiles (e.g. luminal size) while maintaining other key features, such as, for example, radial strength and luminal patency. Advantageously, an axially nested device design allows for use of thicker materials to maintain radial strength, as needed or desired.

[0401] During manufacture and assembly of the axially nested embodiments, the device structural elements (e.g., **814m**, **814f**) and/or ribs (e.g. the female ribs **826f1**, **826f11**, **826f12** and the male ribs **836m11**, **836m21**) are positioned side by side (axially) in the predilated or non-expanded state to substantially reduce or minimize the device crossing profile and bulk in both the undeployed (non-expanded, predilated) and deployed (expanded,

dilated) states. Advantageously, by substantially reducing or eliminating the excess bulk typically encountered with a radially nesting device design, embodiments of the invention can be used to achieve competitive devices and crossing profiles with a wide variety of materials at a wide variety of thicknesses, thereby desirably allowing for optimum device design and performance.

[0402] The articulation between the structural elements **814m1** and **814f1** of a given stent section **812a** is discussed below. As the skilled artisan will recognize, a similar articulation is applicable to other mating structural elements and/or ribs of the stent **810**. Thus, for brevity it is not repeated herein.

[0403] Referring in particular to **FIG. 47**, that is the stent **810'**, the male rib **836m11** includes a pair of outwardly extending stops, tabs, wings or teeth **842m'** with one each extending on each side of the rib **836m11**. The male rib **836m11** also has a radially inwardly pointing bump, stop, tab or tooth **842mb'**.

[0404] During stent expansion, the bump **842mb'** engages respective stops, tabs or teeth **832f'** of the female ribs **826f1**, **826f11** in a one-way slide and lock articulating motion. This is accomplished by utilizing a generally radial deflecting mechanism.

[0405] Thus, during "cross-over" the male rib **836m11** is radially outwardly deflected and then resumes its original undeflected position. This radial motion is generally denoted by arrows **844**. The radial deflection is caused by the generation of a generally radial force when the bump **842m'** and respective teeth **832f'** slide over, engage or abut one another.

[0406] The stops **842m'**, **832f'** are configured to facilitate one-way sliding relative motion as generally shown by arrows **818**. The stops **842m'**, **732f'** are also configured to substantially reduce or minimize recoil. Other suitable configurations that inhibit facilitate one-way motion and undesirable recoil may be efficaciously utilized, as needed or desired.

[0407] The wings **842m'** extend into side slots of one or both of the female ribs **826f1**, **826f11**. Advantageously, this prevents the male rib **836m11** from jumping off the female ribs **826f1**, **826f11** during deployment and keeps the rib **836m11** in its appropriate track.

[0408] At full expansion, one or more hard stops **832fe'** of the structural element portion **828f11** contact, engage or abut against the wings **842m'**, and prevent further stent expansion. This lock-out and capture mechanism provides to control and limit stent expansion to a predetermined deployment diameter.

[0409] Referring in particular to **FIG. 48**, that is the stent **810"**, the articulating between male and female structural elements **814m**, **814f** is generally similar to that described herein with respect to the stent **810'**. Thus, as the skilled artisan will appreciate, it is not repeated herein.

[0410] **FIG. 49** shows two of the stent rows **813f1**, **813f2** in accordance with one embodiment. An injection molding process or the like, among others, may be used to form stent rows **813f1**, **813f2** as integral units. The stent rows **813m1**, **813m2** can also be similarly formed as integral units. The axially extending rows **813f1**, **813m1**, **813f2**, **813m2** can then be connected and rolled into a tubular form in the collapsed state.

[0411] **FIG. 50** shows an exploded view of a lamination stack **878** used to fabricate the stent rows **813** (**813f1**, **813f2**) by a lamination process in accordance with one embodiment. The stent rows **813m1**, **81mf2** can also be similarly formed. The axially extending rows **813f1**, **813m1**, **813f2**, **813m2** can then be connected and rolled into a tubular form in the collapsed state.

[0412] The lamination stack **878** generally comprises three sheets or pallets **878f1**, **878f2**, **878f3** which have the desired features formed thereon, for example, by laser cutting, etching and the like. The pallets **878f1**, **878f2**, **878f3** are aligned and joined, for example, by bonding, welding and the like to form a unit. The excess material (e.g., side and end rails) is removed to form the rows **813** (**813f1**, **813f2**).

[0413] The pallet **878f1** includes features that correspond to stops engaged by an articulating female rib. The pallet **878f2** includes features that correspond to hard stops that control and limit the diameter in collapsed and fully deployed states. The pallet **878f3** includes features that correspond to teeth that align and hold the articulating rib in place.

[0414] **FIGS. 51-56** show various conceptual views of axially nested one-way slide and lock stent geometries and configurations in accordance with embodiments of the invention. The nesting utilizes a "telescope" concept. The drawings show embodiments of

stent sections, segments or frames **912a** with structural elements **914mf**. The stent sections include articulating mechanisms that may comprises radially deflecting locking mechanisms or axially (laterally) deflecting locking mechanisms. These slide and lock articulating mechanisms may include tongue-groove configurations stops, tabs, wings or teeth that provide radially and/or axially deflecting mechanisms for stent expansion and lock-out. Any of the articulating mechanism as disclosed, taught or suggested herein including any disclosed, taught or suggested by the embodiments of **FIGS. 51-56** may efficaciously be used, as needed or desired.

[0415] The embodiments of **FIGS. 51-56** can include capture mechanisms that serve to control and limit stent expansion to a predetermined deployment diameter. Each section **912** and/or structural element **914** can comprise one or more capture mechanisms such as straps, hard stops, and the like among other suitable devices that prevent further expansion between mating structural elements **914** and control the maximum expansion. Any of the capture mechanisms as disclosed, taught or suggested herein may efficaciously be used in conjunction with the embodiments of **FIGS. 51-56**, as needed or desired.

Some Additional Stent Embodiments

[0416] **FIGS. 57-62** show views of an expandable axially nested slide and lock vascular device, prosthesis or stent **1010** including deployed and undeployed states. In a rolled configuration, the stent **1010** has a tubular form with a wall comprising a plurality of generally longitudinally arranged linked circumferential sections, segments or frames **1012a**, **1012s**. The stent **1010** is expandable from a first diameter to a second diameter. The general design of the stent **1010** may be conceptually characterized as a one-way sliding “telescope-like” configuration.

[0417] Advantageously, the axially nested embodiments of the stent **1010** allow suitable crossing profiles (e.g. luminal size) while maintaining desirable radial strength and luminal patency. In the non-expanded state, there is also minimal or reduced overlap between structural elements, so that the luminal size facilitates insertion of a guiding catheter balloon or the like to expand the vascular device.

[0418] The stent **1010** comprises alternatingly arranged slide and lock sections **1012a** and linkage sections **1012s**. Each section **1012a** includes three structural elements **1014mf1**, **1014mf2**, **1014mf3** that each slidingly mate with one another via respective interlocking articulating mechanisms **1016mf1**, **1016mf2**, **1016mf3**. (Each of the structural elements **1014** may also be described as comprising two structural elements – one male and one female - since each mates at two circumferential locations.)

[0419] Each linkage section **1012s** includes three elements **1022mf1**, **1022mf2**, **1022mf3**. The linkage elements **1022mf1** connect structural elements **1014mf1** to form a stent element row **1013mf1**. The linkage elements **1022mf2** connect structural elements **1014mf2** to form a stent element row **1013mf2**. The linkage elements **1022mf3** connect structural elements **1014mf3** to form a stent element row **1013mf3**. The number of elements in a section or row and the number of sections and rows in a stent may be efficaciously varied and selected, as needed or desired.

[0420] One or more of the linkage elements **1022** may comprise spring elements. The spring elements **1022** provide device flexibility and allow expansion of the linkage sections **1012s** along with stent expansion. The spring elements **1022** can also allow for radial and/or axial element or member deflection during stent expansion to a deployed state. The spring elements **1022** facilitate this deflection by providing a resilient biasing mechanism to achieve substantially elastic deflection or deformation.

[0421] The linkage elements **1022mf1** axially or longitudinally connect the structural elements **1014mf1**. In one embodiment, the linkage elements **1022mf1** and the structural elements **1014mf1** comprise an integral unit, that is, the stent row **1013mf1** comprises an integral unit. In modified embodiments, the linkage elements **1022mf1** and the structural elements **1014mf1** can efficaciously be connected by other techniques, as needed or desired.

[0422] The linkage elements **1022mf2** axially or longitudinally connect the structural elements **1014mf2**. In one embodiment, the linkage elements **1022mf2** and the structural elements **1014mf2** comprise an integral unit, that is, the stent row **1013mf2** comprises an integral unit. In modified embodiments, the linkage elements **1022mf2** and the

structural elements **1014mf2** can efficaciously be connected by other techniques, as needed or desired.

[0423] The linkage elements **1022mf3** axially or longitudinally connect the structural elements **1014mf3**. In one embodiment, the linkage elements **1022mf3** and the structural elements **1014mf3** comprise an integral unit, that is, the stent row **1013mf3** comprises an integral unit. In modified embodiments, the linkage elements **1022mf3** and the structural elements **1014mf3** can efficaciously be connected by other techniques, as needed or desired.

[0424] In some embodiments, each of the axially extending rows **1013mf1**, **1013mf2**, **1013mf3** are first formed as independent units that may be independent integral units. The stent rows **1013mf1**, **1013mf2**, **1013mf3** are then connected and rolled into a tubular form in the collapsed state.

[0425] The axial or longitudinal coupling between the structural elements **1014** of adjacent sections **1012a**, the radial coupling between structural elements **1014** of the same section **1012a**, and the design and configuration of the sections **1012** and structural elements **1014** are such that there is minimal or reduced overlapping in the radial or circumferential direction between the structural elements **1014**, in particular in the expanded or deployed state. Thus, the structural elements **1014**, sections **1012** and/or stent **1010** are referred to as being axially, longitudinally or non-radially nested. (There is also minimal or reduced radial overlap between linkage elements **1022** of the same and adjacent sections **1012s** in both the undeployed and deployed states, and more particularly in the deployed state.)

[0426] During stent expansion, there is circumferential relative motion between the mating structural elements **1014mf1**, **1014mf2**, **1014mf3** as generally shown by arrows **1018**. One or more or all of structural elements **1014mf1**, **1014mf2**, **1014mf3** in any suitable combination may slidably move apart.

[0427] Each of the structural elements **1014mf1**, **1014mf2**, **1014mf3** has a generally similar structure and each comprises a male portion and a female portion. Thus, for brevity, only the male portion of the structural element **1014mf1** and the female portion of the structural element **1014mf2** and their articulation, lock-out and capture features are described in detail below.

[0428] It is to be understood that a generally similar arrangement is encompassed by the other structural elements **1014** of the stent **1010**, and similar reference numerals are used herein. Thus, for example, if the male ribs of the structural element **1014mf1** are denoted by **1036m1**, then the male ribs of the structural elements **1014mf2** and **1014mf3** are respectively denoted by **1036m2** and **1026m3**, and so on.

[0429] The male portion of the structural element **1014mf1** mates or articulates with the female portion of the structural element **1014mf2** in a one-way sliding manner. Similarly, the male portion of the structural element **1014mf2** mates or articulates with the female portion of the structural element **1014mf3** in a one-way sliding manner. Also similarly, the male portion of the structural element **1014mf3** mates or articulates with the female portion of the structural element **1014mf1** in a one-way sliding manner. As discussed above and below herein, the slide and lock articulating mechanisms of the structural elements **1014** include features such as deflectable elements or members, tongue-groove configuration stops, tabs or teeth that provide axially deflecting mechanisms for stent expansion and lock-out.

[0430] The male portion of the structural element **1014mf1** generally includes a pair of spaced ribs or arms **1036m1** with a gap therebetween. The male ribs **1036m1** converge towards one another to terminate and join at a common end portion **1038m1**.

[0431] As best seen in FIGS. 61 and 62, the end portion **1038m1** includes a radially inwards extending end tab, tooth or stop **1042me1** that terminates in a pair of outwardly and axially extending tabs, teeth, stops or wings **1042m1**. As discussed further below, the end stop **1042me1** engages the female portion of the adjacent structural element **614mf2** in a one-way slide and lock articulating motion. The end stop **1014me1** is configured to substantially reduce or minimize recoil.

[0432] As discussed further below, the end stop **1042me1** also serves as a safety hard stop in the collapsed state and at full stent expansion. At full expansion, the end stop **1042me1** engages a capture mechanism of the mating structural element **1014mf2** to control and limit the maximum stent expansion to a predetermined deployment diameter. Other suitable lock-out and capture configurations may be efficaciously utilized, as needed or desired.

[0433] Referring in particular to FIGS. 61 and 62, the female portion of the structural element 1014mf2 generally comprises a pair of spaced ribs or arms 1026f2 within the gap between the male ribs 1036m2. The female ribs 1026f2 are radially inwardly recessed relative to the male ribs 1036m2 to provide clearance space for the mating male ribs 1036m1 in the collapsed state and during stent expansion. The female ribs 1026f1 are connected by an end portion 1028f1 that has one or more hard stops 1032fe2 that control and limit the maximum stent expansion to a predetermined diameter.

[0434] Each of the ribs 1026f2 includes a pair of spaced sub-ribs, -arms or rails 1026f21, 1026f22. The rails 1026f21 are axially deflectable and have a plurality of inwardly axially extending stops, tabs or teeth 1032f2. As discussed further below, the teeth 1032f2 engage the male portion of the radially coupled structural element 1014mf1 in a one-way slide and lock articulating motion, and in one embodiment, are not deflectable.

[0435] The teeth 1032f2 are configured so that they have generally flat end surfaces to substantially reduce or minimize recoil and generally tapered engaging surfaces to facilitate one-way sliding. Other suitable configurations that inhibit undesirable recoil and facilitate one-way expansion may be efficaciously utilized, as needed or desired.

[0436] Each of the ribs 1026f22 includes an axial deflection control device, bump or protrusion 1032f22b that is spaced by a predetermined amount from a respective one of the deflectable rails or ribs 1026f21. Advantageously, the bumps 1032f22b serve to control the maximum deflection of the rails or ribs 1026f21 so that they do not deform or bend beyond a prescribed range. The bumps 1032f22b also desirably act as "speed bumps" to control deployment and maintain uniformity of deployment.

[0437] Advantageously, there is substantially no or minimal overlap between nesting structural elements 1014mf1, 1014mf2 and 1014mf3 in both the collapsed state and the expanded state, and more particularly in the expanded state. Thus, the stent 1010, its sections 1012a and/or structural elements 1014 are referred to as being axially nested. Any overlap in the collapsed state is such that a suitable crossing profile is still achieved.

[0438] Embodiments of the invention provide an axially nested vascular device 1010 to achieve both competitive crossing profiles (e.g. luminal size) while maintaining other key features, such as, for example, radial strength and luminal patency. Advantageously, an

axially nested device design allows for use of thicker materials to maintain radial strength, as needed or desired.

[0439] During manufacture and assembly of the axially nested embodiments, at least some of the device ribs (e.g. the male ribs **1036m1** and the male ribs **1036m1**) are positioned side by side (axially) in the predilated or non-expanded state to substantially reduce or minimize the device crossing profile and bulk in both the undeployed (non-expanded, predilated) and deployed (expanded, dilated) states. Advantageously, by substantially reducing or eliminating the excess bulk typically encountered with a radially nesting device design, embodiments of the invention can be used to achieve competitive devices and crossing profiles with a wide variety of materials at a wide variety of thicknesses, thereby desirably allowing for optimum device design and performance.

[0440] The articulation between the structural elements **1014mf1** and **1014mf2** of a given stent section **1012a** is discussed below. As the skilled artisan will recognize, a similar articulation is applicable to other mating structural elements of the stent **1010**. Thus, for brevity it is not repeated herein.

[0441] During stent expansion, there is circumferential relative motion between the ribs of the structural element **1014mf1** and the ribs of the structural element **1014mf1** as generally indicated by arrows **1018**. The male ribs **1036m1** withdraw from the gap between the ribs **1036m2**.

[0442] The end stop **1042me1** slides within the gap between the female ribs **1026f21** and the wings **1042m1** slide along the lower or radially inwards surface of the female toothed ribs **1026f21**. Advantageously, the ribs **1026f21** and/or wings **1042m1** prevent the male ribs **1036m1** from jumping out of their track and keep them in position.

[0443] The stop **1042me1** engages the teeth **1032f2** of the female ribs **1026f21**. Thus, during expansion, the teeth **1032f2** of the deflectable female ribs **1026f21** and the stop **1042me1** cross one another. This is accomplished by utilizing a generally axially deflecting mechanism.

[0444] Thus, during "cross-over" the deflectable female ribs **1026f21** are deflected axially outwards and then resume their original undeflected position. This axial motion is generally denoted by arrows **1044**. The axial deflection is caused by the generation

of a generally axial force when the teeth **1032f2** and the stop **1042me1** slide over, engage or abut one another. Advantageously, the axial deflection control bumps **1032f22b** substantially prevent undesirable or excessive deflection and control deployment to maintain uniformity of deployed stent.

[0445] At full expansion, the safety hard stop **1042me1** and the respective end hard stops **1032fe2** of the structural element portion **1028f2** contact, engage or abut against one other, and prevent further stent expansion. This lock-out and capture mechanism provides to control and limit stent expansion to a predetermined deployment diameter.

[0446] The internal protected articulating and locking mechanisms of the stent **1010** advantageously allow clearance space at the outer stent periphery which shields and protects the mechanisms from external surface interferences. Raised and recessed portions of the structural elements **1014mf** can provide this shielding and the structural elements **1014mf** are also configured to facilitate alignment between the mating elements.

[0447] FIG. 63 shows an expandable axially nested slide and lock vascular device, prosthesis or stent **1010'** in accordance with another embodiment. The stent **1010'** is generally similar to the stent **1010** except that it has linkage sections **1012s'** that have a modified construction.

[0448] Each linkage section **1012s'** includes three elements **1022mf'** that are generally similar to one another. Each linkage element **1022mf'** generally comprises a plurality of interconnected sub-elements **1022mfs'**. One or more of the linkage elements **1022mf'** and/or the sub-elements **1022mfs'** may comprise spring elements, as needed or desired.

Metal Stents and Methods of Manufacturing

[0449] Preferred materials for making the stents in accordance with some embodiments of the invention include cobalt chrome, 316 stainless steel, tantalum, titanium, tungsten, gold, platinum, iridium, rhodium and alloys thereof or pyrolytic carbon. In still other alternative embodiments, the stents may be formed of a corrodible material, for instance, a magnesium alloy. Although preferred stent embodiments have been described as being conventional balloon expandable stents, those skilled in the art will appreciate that

stent constructions according to the present invention may also be formed from a variety of other materials to make a stent crush-recoverable. For example, in alternative embodiments, such as self expandable stents, shape memory alloys that allow for such as Nitinol and Elastinite® may be used in accordance with embodiments of the invention.

[0450] Preferably, sheets are work-hardened prior to forming of the individual stent elements to increase strength. Methods of work hardening are well known in the art. Sheets are rolled under tension, annealed under heat and then re-worked. This may be continued until the desired modulus of hardness is obtained. Most stents in commercial use today employ 0% to 10% work hardened material in order to allow for "softer" material to deform to a larger diameter. In contrast, because expansion of the sliding and locking radial elements in accordance with embodiments of the invention depends on sliding rather than material deformation, it is preferred to use harder materials, preferably in the range of about 25-95% work hardened material to allow for thinner stent thickness. More preferably, the stent materials are 50-90% work hardened and most preferably, the materials are 80-85% work hardened.

[0451] Preferred methods of forming the individual elements from the metal sheets may be laser cutting, laser ablation, die-cutting, chemical etching, plasma etching and stamping and water jet cutting of either tube or flat sheet material or other methods known in the art which are capable of producing high-resolution components. The method of manufacture, in some embodiments, depends on the material used to form the stent. Chemical etching provides high-resolution components at relatively low price, particularly in comparison to high cost of competitive product laser cutting. Some methods allow for different front and back etch artwork, which could result in chamfered edges, which may be desirable to help improve engagements of lockouts. Further one may use plasma etching or other methods known in the art which are capable of producing high-resolution and polished components. The current invention is not limited to the means by which stent or stent elements can be fabricated.

[0452] Once the base geometry is achieved, the elements can be assembled numerous ways. Tack-welding, adhesives, mechanical attachment (snap-together and/or weave together), and other art-recognized methods of attachment, may be used to fasten the

individual elements. Some methods allow for different front and back etch artwork, which could result in chamfered edges, which may be desirable to help improve engagements of lockouts. In one preferred method of manufacture, the components of the stent may be heat set at various desired curvatures. For example, the stent may be set to have a diameter equal to that of the deflated balloon, as deployed, at a maximum diameter, or greater than the maximum diameter. In yet another example, elements can be electropolished and then assembled, or electropolished, coated, and then assembled, or assembled and then electropolished.

[0453] In another embodiment, in particular with shape memory alloys, the stent is heat set at beyond the maximum diameter then built mid diameter than placed over catheter and reverse ratcheted and locked into smaller diameter and onto catheter with positive catch hold down mechanism to achieve a small profile and excellent retention.

Polymeric Stents

[0454] While metal stents possess certain desirable characteristics, the useful lifespan of a stent is estimated to be in the range of about 6 to 9 months, the time at which in-stent restenosis stabilizes and healing plateaus. In contrast to a metal stent, a bioresorbable stent may not outlive its usefulness within the vessel. Moreover, a bioresorbable stent may be used to deliver a greater dose of a therapeutic agent, deliver multiple therapeutic agents at the same time or at various times of its life cycle, to treat specific aspects or events of vascular disease. Additionally, a bioresorbable stent may also allow for repeat treatment of the same approximate region of the blood vessel. Accordingly, there remains an important unmet need to develop temporary (i.e., bioresorbable and/or radiopaque) stents, wherein the polymeric materials used to fabricate these stents have the desirable qualities of metal (e.g., sufficient radial strength and radiopacity, etc.), while circumventing or alleviating the many disadvantages or limitations associated with the use of permanent metal stents.

[0455] In one preferred embodiment, the stent may be formed from biocompatible polymers that are bio-resorbable (e.g., bio-erodible or bio-degradable). Bio-resorbable materials are preferably selected from the group consisting of any hydrolytically degradable and/or enzymatically degradable biomaterial. Examples of suitable degradable polymers

include, but are not limited to, polyhydroxybutyrate /polyhydroxyvalerate copolymers (PHV/PHB), polyesteramides, polylactic acid, hydroxy acids (i.e. lactide, glycolide, hydroxybutyrate), polyglycolic acid, lactone based polymers, polycaprolactone, poly(propylene fumarate-co-ethylene glycol) copolymer (aka fumarate anhydrides), polyamides, polyanhydride esters, polyanhydrides, polylactic acid/polyglycolic acid with a calcium phosphate glass, polyorthesters, silk-elastin polymers, polyphosphazenes, copolymers of polylactic acid and polyglycolic acid and polycaprolactone, aliphatic polyurethanes, polyhydroxy acids, polyether esters, polyesters, polydepsidpetides, polysaccharides, polyhydroxyalkanoates, and copolymers thereof.

[0456] In one mode, the degradable materials are selected from the group consisting of poly(glycolide-trimethylene carbonate), poly(alkylene oxalates), polyaspartimic acid, polyglutarunic acid polymer, poly-p-dioxanone, poly-.beta.-dioxanone, asymmetrically 3,6-substituted poly-1,4-dioxane-2,5-diones, polyalkyl-2-cyanoacrylates, polydepsipeptides (glycine-DL-lactide copolymer), polydihydropyranes, polyalkyl-2-cyanoacrylates, poly-.beta.-maleic acid (PMLA), polyalkanotes and poly-.beta.-alkanoic acids. There are many other degradable materials known in the art. (See e.g., *Biomaterials Science: An Introduction to Materials in Medicine* (29 July, 2004) Ratner, Hoffman, Schoen, and Lemons; and Atala, A., Mooney, D. *Synthetic Biodegradable Polymer Scaffolds*. 1997 Birkhauser, Boston; incorporated herein by reference).

[0457] Further still, in a more preferred embodiment, the stents may be formed of a polycarbonate material, such as, for example, tyrosine-derived polycarbonates, tyrosine-derived polyarylates, iodinated and/or brominated tyrosine-derived polycarbonates, iodinated and/or brominated tyrosine-derived polyarylates. For additional information, see U.S. Patent Nos. 5,099,060, 5,198,507, 5,587,507, 5,658,995, 6,048,521, 6,120,491, 6,319,492, 6,475,477, 5,317,077, and 5,216,115, each of which is incorporated by reference herein. In another preferred embodiment, the polymer is any of the biocompatible, bioabsorbable, radiopaque polymers disclosed in U.S. Patent Application Nos. 60/601,526; 60/586,796; and 10/952,202 the entire disclosures of which are incorporated herein by reference thereto.

[0458] Natural polymers (biopolymers) include any protein or peptide. Preferred biopolymers may be selected from the group consisting of alginate, cellulose and ester,

chitosan, collagen, dextran, elastin, fibrin, gelatin, hyaluronic acid, hydroxyapatite, spider silk, cotton, other polypeptides and proteins, and any combinations thereof.

[0459] In yet another alternative embodiment, shape-shifting polymers may be used to fabricate stents constructed according to the present invention. Suitable shape-shifting polymers may be selected from the group consisting of polyhydroxy acids, polyorthoesters, polyether esters, polyesters, polyamides, polyesteramides, polydepsidpetides, aliphatic polyurethanes, polysaccharides, polyhydroxyalkanoates, and copolymers thereof. For addition disclosure on bio-degradable shape-shifting polymers, see U.S. Patent No. 6,160,084, which is incorporated by reference herein. For additional disclosure on shape memory polymers, see U.S. Patent Nos. 6,388,043 and 6,720,402, each of which are incorporated by reference herein. Further the transition temperature may be set such that the stent is in a collapsed condition at a normal body temperature. However, with the application of heat during stent placement and delivery, such as via a hot balloon catheter or a hot liquid (e.g., saline) perfusion system, the stent expands to assume its final diameter in the body lumen. When a thermal memory material is used, it may provide a crush-recoverable structure.

[0460] Further still, stents may be formed from biocompatible polymers that are biostable (e.g., non-degrading and non-erodible). Examples of suitable non-degrading materials include, but are not limited to, polyurethane, Delrin, high density polyethylene, polypropylene, and poly(dimethyl siloxane).

[0461] In some embodiments, the layers may comprise or contain any example of thermoplastics, such as the following, among others: fluorinated ethylene-propylene, poly(2-hydroxyethylmethacrylate (aka pHEMA), poly(ethylene terephthalate) fiber (aka Dacron®) or film (Mylar®), poly(methyl methacrylate (aka PMMA), Poly(tetraflouroethylene) (aka PTFE and ePTFE and Gore-Tex®), poly(vinylchloride), polyacrylates and polyacrylonitrile (PAN), polyamides (aka Nylon), polycarbonates and polycarbonate urethanes, polyethylene and poly(ethylene-co-vinyl acetate), polypropylene, polystyrene, polysulphone, polyurethane and polyetherurethane elastomers such as Pellethane® and Estane®, Silicone rubbers, Siloxane, polydimethylsiloxane (aka PDMS), Silastic®, Siliconized Polyurethane.

Methods of Manufacturing and Assembling Polymeric Stents

[0462] Where plastic and/or degradable materials are used, the elements may be made using laser ablation with a screen, stencil or mask; solvent casting; forming by stamping, embossing, compression molding, centripetal spin casting and molding; extrusion and cutting, three-dimensional rapid prototyping using solid free-form fabrication technology, stereolithography, selective laser sintering, or the like; etching techniques comprising plasma etching; textile manufacturing methods comprising felting, knitting, or weaving; molding techniques comprising fused deposition modeling, injection molding, room temperature vulcanized molding, or silicone rubber molding; casting techniques comprising casting with solvents, direct shell production casting, investment casting; pressure die casting, resin injection, resin processing electroforming, or injection molding or reaction injection molding. Certain preferred embodiments with the present polymers may be shaped into stents via combinations of two or more thereof, and the like.

[0463] Such processes may further include two-dimensional methods of fabrication such as cutting extruded sheets of polymer, via laser cutting, etching, mechanical cutting, or other methods, and assembling the resulting cut portions into stents, or similar methods of three-dimensional fabrication of devices from solid forms. For additional information, see U.S. Patent Application No. 10/655,338, which is incorporated by reference herein.

[0464] Stents of the preferred embodiment are manufactured with elements prepared in full stent lengths or in partial lengths of which two or more are then connected or attached. If using partial lengths, two or more may be connected or attached to comprise a full length stent. In this arrangement the parts are assembled to give rise to a central opening. The assembled full or partial length parts and/or modules may be assembled by inter-weaving them in various states, from a collapsed state, to a partially expanded state, to an expanded state.

[0465] Further, elements may be connected or attached by solvent or thermal bonding, or by mechanical attachment. If bonding, preferred methods of bonding comprise the use of ultrasonic radiofrequency or other thermal methods, and by solvents or adhesives

or ultraviolet curing processes or photoreactive processes. The elements may be rolled by thermal forming, cold forming, solvent weakening forming and evaporation, or by preforming parts before linking.

[0466] Another method of manufacture allows for assembly of the stent components that have been cut out and assembled into flat series of radial elements. The linkage elements between longitudinally adjacent series of radial elements may be connected (e.g., by welding, inter-weaving frame elements, etc.), the flat sheets of material are rolled to form a tubular member. Coupling arms from floating coupling elements and end portions may be joined (e.g., by welding) to maintain the tubular shape. In embodiments that do not include coupling elements, the end portions of the top and bottom radial elements in a series may be joined. Alternatively, where sliding is desired throughout the entire circumference, a sliding and locking articulation can be made between the end portion of the top radial element and the rib(s)/rails of the bottom radial element (e.g., by tack-welding, heat-staking or snap-together). Similarly, a corresponding articulation can be made between the end portion of the bottom radial element and the rib(s)/rails of the top radial element.

[0467] Rolling of the flat series of module(s) to form a tubular member can be accomplished by any means known in the art, including rolling between two plates, which are each padded on the side in contact with the stent elements. One plate is held immobile and the other can move laterally with respect to the other. Thus, the stent elements sandwiched between the plates may be rolled about a mandrel by the movement of the plates relative to one another. Alternatively, 3-way spindle methods known in the art may also be used to roll the tubular member. Other rolling methods that may be used in accordance with the present invention include those used for "jelly-roll" designs, as disclosed for example, in U.S. Pat. Nos. 5,421,955, 5,441,515, 5,618,299, 5,443,500, 5,649,977, 5,643,314 and 5,735,872; the disclosures of which are incorporated herein in their entireties by reference thereto.

[0468] The construction of the slide-and-lock stents in these fashions provides a great deal of benefit over the prior art. The construction of the locking mechanism is largely material-independent. This allows the structure of the stent to comprise high strength materials, not possible with designs that require deformation of the material to complete the locking mechanism. The incorporation of these materials will allow the thickness required of

the material to decrease, while retaining the strength characteristics of thicker stents. In preferred embodiments, the frequency of catches, stops or teeth present on selected circumferential elements prevents unnecessary recoil of the stent subsequent to expansion.

Radiopacity

[0469] Traditional methods for adding radiopacity to a medical product include the use of metal bands, inserts and/or markers, electrochemical deposition (i.e., electroplating), or coatings. The addition of radiopacifiers (i.e., radiopaque materials) to facilitate tracking and positioning of the stent could be accommodated by adding such an element in any fabrication method, by absorbing into or spraying onto the surface of part or all of the device. The degree of radiopacity contrast can be altered by element content.

[0470] For plastics and coatings, radiopacity may be imparted by use of monomers or polymers comprising iodine or other radiopaque elements, i.e., inherently radiopaque materials. Common radiopaque materials include barium sulfate, bismuth subcarbonate, and zirconium dioxide. Other radiopaque elements include: cadmium, tungsten, gold, tantalum, bismuth, platinum, iridium, and rhodium. In one preferred embodiment, a halogen such as iodine and/or bromine may be employed for its radiopacity and antimicrobial properties.

Multi-Material Vascular Prosthesis

[0471] In still other alternative embodiments, various materials (e.g., metals, polymers, ceramics, and therapeutic agents) may be used to fabricate stent embodiments. The embodiments may comprise: 1) differentially layered materials (through the vertical or radial axis) to create a stack of materials (materials may be stacked in any configuration, e.g., parallel, staggered, etc.); 2) spatially localized materials which may vary along the long axis and/or thickness of the stent body; 3) materials that are mixed or fused to create a composite stent body; 4) embodiments whereby a material is laminated (or coated) on the surface of the stent body (see Stent Surface Coatings with Functional Properties as well as see Therapeutic Agents Delivered by Stents); and, 5) stents comprised of 2 or more parts where at least one part is materially distinct from a second part, or any combination thereof.

[0472] The fashioning of a slide-and-lock multi-material stent can have between two or more materials. Thickness of each material may vary relative to other materials. This approach as needed or desired allows an overall structural member to be built with each material having one or more functions contributing towards enabling prosthesis function which includes, but is not limited to: 1) enabling mechanical properties for stent performance as defined by ultimate tensile strength, yield strength, Young's modulus, elongation at yield, elongation at break, and Poisson's ratio; 2) enabling the thickness of the substrate, geometrical shape (e.g., bifurcated, variable surface coverage); 3) enabling chemical properties of the material that bear relevance to the materials performance and physical state such as rate of degradation and resorption (which may impact therapeutic delivery), glass transition temperature, melting temperature, molecular weight; 4) enabling radiopacity or other forms of visibility and detection; 5) enabling radiation emission; 6) enabling delivery of a therapeutic agent (see Therapeutic Agents Delivered by Stents); and 7) enabling stent retention and/or other functional properties (see Stent Surface Coatings with Functional Properties).

[0473] In some embodiments, the materials may comprise load-bearing properties, elastomeric properties, mechanical strength that is specific to a direction or orientation e.g., parallel to another material and/or to the long axis of the stent, or perpendicular or uniform strength to another material and/or stent. The materials may comprise stiffeners, such as the following, boron or carbon fibers, pyrolytic carbon. Further, stents may be comprised of at least one re-enforcement such a fibers, nanoparticles or the like.

[0474] In another preferred mode of the invention, the stent is made, at least in part, from a polymeric material, which may be degradable. The motivation for using a degradable stent is that the mechanical support of a stent may only be necessary for several weeks. In some embodiments, bioresorbable materials with varying rates of resorption may be employed. For additional information, see U.S. Patent Application No. 10/952,202 and 60/601,526, which are incorporated by reference herein. Degradable polymeric stent materials may be particularly useful if it also controls restenosis and thrombosis by delivering

pharmacologic agents. Degradable materials are well suited for therapeutic delivery (see Therapeutic Agents Delivered by Stents).

[0475] In some embodiments, the materials may comprise or contain any class of degradable polymer as previously defined. Along with variation in the time of degradation and/or resorption the degradable polymer may have other qualities that are desirable. For example, in some embodiments the materials may comprise or contain any example of natural polymers (biopolymers) and/or those that degrade by hydrolytic and/or enzymatic action. In some embodiments, the material may comprise or contain any example of hydrogels that may or may not be thermally reversible hydrogels, or any example of a light or energy curable material, or magnetically stimulateable (responding) material. Each of these responses may provide for a specific functionality.

[0476] In some embodiments, the materials may comprise or be made from or with constituents which has some radiopaque material alternatively, a clinically visible material which is visible by x-ray, fluoroscopy, ultrasound, MRI, or Imatron Electron Beam Tomography (EBT).

[0477] In some embodiments, one or more of the materials may emit predetermined or prescribed levels of therapeutic radiation. In one embodiment, the material can be charged with beta radiation. In another embodiment, the material can be charged with Gamma radiation. In yet another embodiment, the material can be charged with a combination of both Beta and Gamma radiation. Stent radioisotopes that may be used include, but are not limited to, ^{103}Pd and ^{32}P (phosphorus-32) and two neutron-activated examples, ^{65}Cu and $^{87}\text{Rb}_2\text{O}$, ^{90}Sr , tungsten-188 (188).

[0478] In some embodiments, one or more of the materials may comprise or contain a therapeutic agent. The therapeutic agents may have unique, delivery kinetics, mode of action, dose, half-life, purpose, et cetera. In some embodiments, one or more of the materials comprise an agent which provides a mode and site of action for therapy for example by a mode of action in the extracellular space, cell membrane, cytoplasm, nucleus and/or other intracellular organelle. Additionally an agent that serves as a chemoattractant for specific cell types to influence tissue formation and cellular responses for example host-biomaterial interactions, including anti-cancer effects. In some embodiments, one or more of

the materials deliver cells in any form or state of development or origin. These could for example be encapsulated in a degradable microsphere, or mixed directly with polymer, or hydrogel and serve as vehicle for pharmaceutical delivery. Living cells could be used to continuously deliver pharmaceutical type molecules, for instance, cytokines and growth factors. Nonliving cells may serve as a limited release system. For additional concepts of therapeutic delivery, see the section entitled: Therapeutic Agents Delivered by Stents.

Therapeutic Agents Delivered by Stents

[0479] In another preferred variation, the stent further comprises an amount of a therapeutic agent (as previously defined for a pharmaceutical agent and/or a biologic agent) sufficient to exert a selected therapeutic effect. In some preferred embodiments of the stent (e.g., polymer stents and multi-material stents) the therapeutic agent is contained within the stent as the agent is blended with the polymer or admixed by other means known to those skilled in the art. In other preferred embodiments of the stent, the therapeutic agent is delivered from a polymer coating on the stent surface. In some preferred embodiments of the stent a therapeutic agent is localized in or around a specific structural aspect of the device.

[0480] In another preferred variation the therapeutic agent is delivered by means of a non-polymer coating. In other preferred embodiments of the stent, the therapeutic agent is delivered from at least one region or one surface of the stent. The therapeutic can be chemically bonded to the polymer or carrier used for delivery of the therapeutic from at least one portion of the stent and/or the therapeutic can be chemically bonded to the polymer that comprises at least one portion of the stent body. In one preferred embodiment, more than one therapeutic agent may be delivered.

[0481] The amount of the therapeutic agent is preferably sufficient to inhibit restenosis or thrombosis or to affect some other state of the stented tissue, for instance, heal a vulnerable plaque, and/or prevent rupture or stimulate endothelialization or limit other cell types from proliferating and from producing and depositing extracellular matrix molecules. The agent(s) may be selected from the group consisting of antiproliferative agents, anti-inflammatory, anti-matrix metalloproteinase, and lipid lowering, cholesterol modifying, anti-thrombotic and antiplatelet agents, in accordance with preferred embodiments of the present

invention. Some of these preferred anti-proliferative agents that improve vascular patency include without limitation paclitaxel, Rapamycin, ABT-578, everolimus, dexamethasone, nitric oxide modulating molecules for endothelial function, tacrolimus, estradiol, mycophenolic acid, C6-ceramide, actinomycin-D and epothilones, and derivatives and analogs of each.

[0482] Some of these preferred agents act as an antiplatelet agent, antithrombin agent, compounds to address other pathologic events and/or vascular diseases. Various therapeutic agents may be classified in terms of their sites of action in the host: agents that exert their actions extracellularly or at specific membrane receptor sites, those that act on the plasma membrane, within the cytoplasm, and/or the nucleus.

[0483] In addition to the aforementioned, therapeutic agents may include other pharmaceutical and/or biologic agents intended for purposes of treating body lumens other than arteries and/or veins). Therapeutic agents may be specific for treating nonvascular body lumens such as digestive lumens (e.g., gastrointestinal, duodenum and esophagus, biliary ducts), respiratory lumens (e.g., tracheal and bronchial), and urinary lumens (e.g., urethra). Additionally such embodiments may be useful in lumens of other body systems such as the reproductive, endocrine, hematopoietic and/or the integumentary, musculoskeletal/orthopedic and nervous systems (including auditory and ophthalmic applications); and finally, stent embodiments with therapeutic agents may be useful for expanding an obstructed lumen and for inducing an obstruction (e.g., as in the case of aneurysms).

[0484] Therapeutic release may occur by controlled release mechanisms, diffusion, interaction with another agent(s) delivered by intravenous injection, aerosolization, or orally. Release may also occur by application of a magnetic field, an electrical field, or use of ultrasound.

Stent Surface Coatings with Functional Properties

[0485] In addition to stents that may deliver a therapeutic agent, for instance delivery of a biological polymer on the stent such as a repellent phosphorylcholine, the stent may be coated with other bioresorbable polymers predetermined to promote biological responses in the body lumen desired for certain clinical effectiveness. Further the coating

may be used to mask (temporarily or permanently) the surface properties of the polymer used to comprise the stent embodiment. The coating may be selected from the broad class of any biocompatible bioresorbable polymer which may include any one or combination of halogenated and/or non-halogenated which may or may not comprise any poly(alkylene glycol). These polymers may include compositional variations including homopolymers and heteropolymers, stereoisomers and/or a blend of such polymers. These polymers may include for example, but are not limited to, polycarbonates, polyarylates, poly(ester amides), poly(amide carbonates), trimethylene carbonate, polycaprolactone, polydioxane, polyhydroxybutyrate, poly-hydroxyvalerate, polyglycolide, polylactides and stereoisomers and copolymers thereof, such as glycolide/lactide copolymers. In a preferred embodiment, the stent is coated with a polymer that exhibits a negative charge that repels the negatively charged red blood cells' outer membranes thereby reducing the risk of clot formation. In another preferred embodiment, the stent is coated with a polymer that exhibits an affinity for cells, (e.g., endothelial cells) to promote healing. In yet another preferred embodiment, the stent is coated with a polymer that repels the attachment and/or proliferation of specific cells, for instance arterial fibroblasts and/or smooth muscle cells in order to lessen restenosis and/or inflammatory cells such as macrophages.

[0486] Described above are the stents of the present invention that may be modified with a coating to achieve functional properties that support biological responses. Such coatings or compositions of material with a therapeutic agent may be formed on stents or applied in the process of making a stent body via techniques such as dipping, spray coating, cross-linking combinations thereof, and the like. Such coatings or compositions of material may also serve purpose other than delivering a therapeutic, such as to enhance stent retention on a balloon when the coating is placed intraluminally on the stent body and/or placed over the entire device after the stent is mounted on the balloon system to keep the stent in a collapsed formation. Other purposes can be envisioned by those skilled in the art when using any polymer material.

[0487] In one aspect of the invention, a stent would have a coating applied that has specific mechanical properties. The properties may include *inter alia* thickness, tensile strength, glass transition temperature, and surface finish. The coating is preferably applied

prior to final crimping or application of the stent to the catheter. The stent may then be applied to the catheter and the system may have either heat or pressure or both applied in a compressive manner. In the process, the coating may form frangible bonds with both the catheter and the other stent surfaces. The bonds would enable a reliable method of creating stent retention and of holding the stent crossing profile over time. The bonds would break upon the balloon deployment pressures. The coating would be a lower Tg than the substrate to ensure no changes in the substrate.

Stent Deployment

[0488] First, a catheter is provided wherein an expandable member, preferably an inflatable balloon, such as an angioplasty balloon, is provided along a distal end portion. One example of a balloon catheter for use with a stent is described in U.S. Patent No. 4,733,665 to Palmaz, which is incorporated by reference herein. A stent on a catheter is commonly collectively referred to as a stent system. Catheters include but are not limited to over-the-wire catheters, coaxial rapid-exchange designs and the Medtronic Zipper Technology that is a new delivery platform. Such catheters may include for instance those described in Bonzel U.S. Patent Nos. 4,762,129 and 5,232,445 and by Yock U.S. Patent Nos. 4,748,982; 5,496,346; 5,626,600; 5,040,548; 5,061,273; 5,350,395; 5,451,233 and 5,749,888. Additionally, catheters may include for instance those as described in U.S. Patent Nos. 4,762,129; 5,092,877; 5,108,416; 5,197,978; 5,232,445; 5,300,085; 5,445,646; 5,496,275; 5,545,135; 5,545,138; 5,549,556; 5,755,708; 5,769,868; 5,800,393; 5,836,965; 5,989,280; 6,019,785; 6,036,715; 5,242,399; 5,158,548; and 6,007,545. The disclosures of the above-cited patents are incorporated herein in their entirety by reference thereto.

[0489] Catheters may be specialized with highly compliant polymers and for various purposes such as to produce an ultrasound effect, electric field, magnetic field, light and/or temperature effect. Heating catheters may include for example those described in U.S. Patent No. 5,151,100, 5,230,349; 6,447,508; and 6,562,021 as well as WO9014046A1. Infrared light emitting catheters may include for example those described in U. S. Patent Nos. 5,910,816 and 5,423,321. The disclosures of the above-cited patents and patent publications are incorporated herein in their entirety by reference thereto.

[0490] An expandable member, such as an inflatable balloon, is preferably used to deploy the stent at the treatment site. As the balloon is expanded, the radial force of the balloon overcomes the initial resistance of the constraining mechanism, thereby allowing the stent to expand. As the balloon is inflated, the radial elements slide with respect to each other along the surface of the balloon until the stent has been expanded to a desired diameter.

[0491] The stent of embodiments of the invention are adapted for deployment using conventional methods known in the art and employing percutaneous transluminal catheter devices. This includes deployment in a body lumen by means of a balloon expandable design whereby expansion is driven by the balloon expanding. Alternatively, the stent may be mounted onto a catheter that holds the stent as it is delivered through the body lumen and then releases the stent and allows it to self-expand into contact with the body lumen. The restraining means may comprise a removable sheath and/or a mechanical aspect of the stent design.

[0492] Some embodiments of the invention may be useful in coronary arteries, carotid arteries, vascular aneurysms (when covered with a sheath), and peripheral arteries and veins (e.g., renal, iliac, femoral, popliteal, subclavian, aorta, intercranial, etc.). Other nonvascular applications include gastrointestinal, duodenum, biliary ducts, esophagus, urethra, reproductive tracts, trachea, and respiratory (e.g., bronchial) ducts. These applications may or may not require a sheath covering the stent.

[0493] It is desirable to have the stent radially expand in a uniform manner. Alternatively, the expanded diameter may be variable and determined by the internal diameter and anatomy of the body passageway to be treated. Accordingly, uniform and variable expansion of the stent that is controlled during deployment is not likely to cause a rupture of the body passageway. Furthermore, the stent will resist recoil because the locking means resist sliding of the mating elements. Thus, the expanded intraluminal stent will continue to exert radial pressure outward against the wall of the body passageway and will therefore, not migrate away from the desired location.

[0494] From the foregoing description, it will be appreciated that a novel approach for expanding a lumen has been disclosed. While the components, techniques and aspects of the invention have been described with a certain degree of particularity, it is

manifest that many changes may be made in the specific designs, constructions and methodology herein above described without departing from the spirit and scope of this disclosure.

[0495] While a number of preferred embodiments of the invention and variations thereof have been described in detail, other modifications and methods of using and medical applications for the same will be apparent to those of skill in the art. Accordingly, it should be understood that various applications, modifications, materials, and substitutions may be made of equivalents without departing from the spirit of the invention or the scope of the claims.

[0496] Various modifications and applications of the invention may occur to those who are skilled in the art, without departing from the true spirit or scope of the invention. It should be understood that the invention is not limited to the embodiments set forth herein for purposes of exemplification, but is to be defined only by a fair reading of the appended claims, including the full range of equivalency to which each element thereof is entitled.

References

[0497] Some of the references cited herein are listed below, the entirety of each one of which is hereby incorporated by reference herein:

- Charles R, Sandirasegarane L, Yun J, Bourbon N, Wilson R, Rothstein RP, et al. Ceramide-Coated Balloon Catheters Limit Neointimal Hyperplasia after Stretch Injury in Carotid Arteries. *Circ Res* 2000;87(4):282-288.
- Coroneos E, Martinez M, McKenna S, Kester M. Differential regulation of sphingomyelinase and ceramidase activities by growth factors and cytokines. Implications for cellular proliferation and differentiation. *J Biol Chem* 1995;270(40):23305-9.
- Coroneos E, Wang Y, Panuska JR, Templeton DJ, Kester M. Sphingolipid metabolites differentially regulate extracellular signal-regulated kinase and stress-activated protein kinase cascades. *Biochem J* 1996;316(Pt 1):13-7.

- Jacobs LS, Kester M. Sphingolipids as mediators of effects of platelet-derived growth factor in vascular smooth muscle cells. *Am J Physiol* 1993;265(3 Pt 1):C740-7.
- Tanguay JF, Zidar JP, Phillips HR, 3rd, Stack RS. Current status of biodegradable stents. *Cardiol Clin* 1994;12(4):699-713.
- Nikol S, Huehns TY, Hofling B. Molecular biology and post-angioplasty restenosis. *Atherosclerosis* 1996;123(1-2):17-31.
- *Biomaterials Science: An Introduction to Materials in Medicine* (29 July, 2004)
Ratner, Hoffman, Schoen, and Lemons

WHAT IS CLAIMED IS:

1. A slide-and-lock stent, comprising:
 - a tubular member that is expandable from a collapsed state to an expanded state;
 - the tubular member comprising at least one slide-and-lock section;
 - the slide-and-lock section comprising separate first and second axially nested, slidably coupled structural elements, at least one of which comprises a deflectable structure configured to deflect during expansion from the collapsed state to the expanded state, thereby resisting recoil, and wherein no portion of either structural elements weaves through paired slots in the other structural element.
2. The slide-and-lock stent of Claim 1, wherein the deflectable structure is configured to deflect axially.
3. The slide-and-lock stent of Claim 1, wherein the deflectable structure is configured to deflect radially.
4. The slide-and-lock stent of Claim 1, wherein the first structural element comprises a rib with an axially extending tooth.
5. The slide-and-lock stent of Claim 2, wherein the second structural element comprises a rib with a plurality of axially extending teeth which engage the axially extending tooth of the rib of the first structural element during expansion so that at least one of the ribs is deflected.
6. The slide-and-lock stent of Claim 5, wherein the rib of the first structural element comprises a plurality of teeth which engage the teeth of the rib of the second structural element during expansion so that at least one of the ribs is axially deflected.
7. The slide-and-lock stent of Claim 5, wherein the second structural element comprises a rib with a plurality of axially extending teeth which engage the axially extending tooth of the rib of the first structural element during expansion so that at least one of the ribs is radially deflected.
8. The slide-and-lock stent of Claim 5, wherein the teeth of the rib of the second structural element are arranged in a staggered pattern.

9. The slide-and-lock stent of Claim 1, wherein the stent further comprises at least one more slide-and-lock section.

10. The slide-and-lock stent of Claim 9, wherein the slide-and-lock sections are substantially identical to one another.

11. The slide-and-lock stent of Claim 9, wherein the slide-and-lock sections are different from one another.

12. The slide-and-lock stent of Claim 9, wherein the stent further comprises at least one flexible linkage section connecting adjacent slide-and-lock sections to facilitate the elastic deflection.

13. The slide-and-lock stent of Claim 1, wherein the stent comprises a biocompatible material.

14. The slide-and-lock stent of Claim 13, wherein the stent comprises a bioresorbable polymer.

15. The slide-and-lock stent of Claim 1, wherein the stent comprises a therapeutic agent.

16. The slide-and-lock stent of Claim 15, wherein the therapeutic agent comprises a pharmaceutical agent.

17. The slide-and-lock stent of Claim 15, wherein the therapeutic agent comprises a biological agent.

18. The slide-and-lock stent of Claim 1, wherein the stent comprises a radiopaque material.

19. The slide-and-lock stent of Claim 1, wherein the recoil is less than about 5%.

20. The slide-and-lock stent of Claim 1, wherein a lock-out mechanism controls the maximum stent expansion.

21. A slide-and-lock stent, comprising:

a tubular member that is expandable from a collapsed diameter to an expanded diameter;

the tubular member comprising a first circumferential slide-and-lock section and a second circumferential slide-and-lock section, said slide-and-lock sections being longitudinally arranged and linked;

each of the slide-and-lock sections comprising a first axial element and a second axial element wherein the first and second axial elements are axially offset and connected by an interlocking mechanism;

wherein the first axial element comprises a first rib with at least one axially outwardly extending tooth and the second axial element comprises a second rib with at least one axially inwardly extending tooth; and

wherein the outwardly and inwardly extending teeth engaging one another during expansion and are configured to permit one-way sliding between the first and second axial elements such that at least one of the first and second ribs is axially deflected during expansion from the collapsed diameter to the expanded diameter.

22. The slide-and-lock stent of Claim 21, wherein the tubular member comprises a lumen and the interlocking mechanism between the axial elements substantially eliminates radial overlap and allows for a substantially clear lumen such that substantially no structure protrudes into the lumen.

23. The slide-and-lock stent of Claim 21, wherein said slide-and-lock sections are connected by a linkage section that comprises at least one flexible element.

24. The slide-and-lock stent of Claim 21, wherein the at least one tooth of the first and/or second ribs has a tapered engaging surface and a flat end surface to facilitate one-way sliding.

25. The slide-and-lock stent of Claim 21, wherein the stent further comprises a capture mechanism configured to control stent profile during expansion.

26. The slide-and-lock stent of Claim 25, wherein the capture mechanism comprises a capture strap.

27. The slide-and-lock stent of Claim 25, wherein the capture mechanism inhibits the first and/or second ribs from jumping out of a predetermined track during stent expansion.

28. The slide-and-lock stent of Claim 21, wherein the stent further comprises a capture mechanism configured to control stent profile when the stent is in the collapsed diameter.

29. The slide-and-lock stent of Claim 28, wherein the capture mechanism comprises a capture strap.

30. The slide-and-lock stent of Claim 21, wherein at least one of the first or second ribs comprises a groove that engages the at least one tooth from the other rib, wherein such engagement substantially prevents the ribs from substantially deviating from a predetermined path.

31. The slide-and-lock stent of Claim 21, wherein the maximum stent expansion is controlled by a lock-out mechanism.

32. The slide-and-lock stent of Claim 31, wherein the lock-out mechanism comprises a tongue and groove arrangement.

33. The slide-and-lock stent of Claim 21, wherein the corresponding axial elements of each slide-and-lock section are radially offset.

34. The slide-and-lock stent of Claim 21, wherein each of the second ribs comprises a plurality of engaging teeth.

35. The slide-and-lock stent of Claim 34, wherein each of the first ribs comprises a plurality of engaging teeth.

36. The slide-and-lock stent of Claim 21, wherein each of the second axial elements comprises two ribs with engaging teeth.

37. The slide-and-lock stent of Claim 36, wherein each of the first axial elements comprises two ribs with engaging teeth.

38. The slide-and-lock stent of Claim 21, wherein each of the second ribs comprises a plurality of spaced deflectable fingers that each comprise a plurality of teeth that engage the corresponding first rib during expansion.

39. The slide-and-lock stent of Claim 38, wherein each of the second axial elements comprises an additional rib that comprises a plurality of spaced deflectable fingers that each comprise a plurality of teeth that engage the corresponding first rib during expansion.

40. The slide-and-lock stent of Claim 39, wherein the teeth each of the second axial elements are arranged in an alternating repetitive pattern.

41. The slide-and-lock stent of Claim 39, wherein the deflectable fingers of each second axial element are arranged in a staggered pattern.

42. A slide-and-lock stent, comprising:

a tubular member that is expandable from a first diameter to a second diameter;

the tubular member comprising a first circumferential section and a second circumferential section with said circumferential sections being longitudinally arranged;

a flexible linkage section connecting said circumferential sections;

each of the circumferential sections comprising a first slide-and-lock element and a second slide-and-lock element with the corresponding slide-and-lock elements of each circumferential section being radially connected by a slidable articulating mechanism;

each of the first slide-and-lock elements comprising at least one tooth and each of the second slide-and-lock elements comprising at least one radially extending tooth; and

during expansion, the teeth of the first slide-and-lock elements engaging corresponding radially extending teeth of the second slide and lock sections, said teeth being configured to permit one-way sliding between the corresponding first and second slide-and-lock elements such that at least a portion of the corresponding first and second slide-and-lock elements is radially deflected during expansion from the first diameter to the second diameter.

43. The slide-and-lock stent of Claim 42, wherein the first slide-and-lock elements and the corresponding second slide-and-lock elements are axially nested to substantially eliminate radial overlap between mating slide-and-lock elements thereby allowing for a substantially uniform thickness profile when the stent is expanded to the second diameter.

44. The slide-and-lock stent of Claim 42, wherein the tubular member comprises a lumen and the interlocking between the corresponding slide-and-lock elements substantially eliminates radial overlap and allows for a substantially clear through-lumen such that

substantially no structure protrudes into the lumen when the stent is expanded to the second diameter.

45. The slide-and-lock stent of Claim 42, wherein the radially extending teeth comprise radially outwardly extending teeth.

46. The slide-and-lock stent of Claim 42, wherein at least one of the second slide-and-lock elements comprise a plurality of radially extending teeth

47. The slide-and-lock stent of Claim 42, wherein at least one of the second slide-and-lock elements comprises two spaced ribs and each rib comprises a plurality of radially extending teeth.

48. The slide-and-lock stent of Claim 42, wherein at least one of the first slide-and-lock elements comprises a rib that comprises a pair of axially extending teeth that engage the corresponding plurality of radially extending teeth on corresponding ribs of the corresponding second slide-and-lock element during expansion to the second diameter.

49. The slide-and-lock stent of Claim 42, wherein at least one of the first slide-and-lock elements includes a plurality of radially extending teeth that engage a corresponding plurality of radially extending teeth of at least one of the second slide-and-lock elements during expansion to the second diameter.

50. The slide-and-lock stent of Claim 42, wherein the linkage section comprises at least one spring element.

51. The slide-and-lock stent of Claim 42, wherein the stent further comprises a hard stop to control maximum stent expansion.

52. The slide-and-lock stent of Claim 42, wherein the stent further comprises a raised shielding and alignment strap to provide additional strength and facilitate a curved structure.

53. The slide-and-lock stent of Claim 42, wherein the stent comprises a metal or alloy.

54. The slide-and-lock stent of Claim 42, wherein the stent comprises at least two materials.

55. The slide-and-lock stent of Claim 54, wherein the stent comprises a metal and a polymer.

56. The slide-and-lock stent of Claim 42, wherein the stent comprises a polymeric material.

57. The slide-and-lock stent of Claim 56, wherein the stent comprises a bio-resorbable material.

58. The slide-and-lock stent of Claim 57, wherein the stent comprises a bio-erodible material.

59. The slide-and-lock stent of Claim 57, wherein the stent comprises a bio-degradable material.

60. The slide-and-lock stent of Claim 56, wherein the stent comprises a bio-stable material.

61. The slide-and-lock stent of Claim 60, wherein the stent comprises a non-degrading material.

62. The slide-and-lock stent of Claim 60 wherein the stent comprises a non-erodible material.

63. The slide-and-lock stent of Claim 42, wherein the stent is fabricated by a lamination process.

64. The slide-and-lock stent of Claim 62 wherein the stent is fabricated by a laser cutting process.

65. The slide-and-lock stent of Claim 42, wherein the stent further comprises a coating to alter a physical characteristic of the stent.

66. The slide-and-lock stent of Claims 1, 21 or 42, wherein the stent further comprises a polymeric sheath.

67. A system for treating a site within a vessel, comprising a catheter having a deployment means, and any stent of Claims 1, 21 or 42, wherein said catheter is adapted to deliver the stent to said site and said deployment means is adapted to deploy the stent.

68. The system of Claim 67, wherein said catheter is selected from the group consisting of over-the-wire catheters, coaxial rapid-exchange catheters, and multi-exchange delivery catheters.

69. A method for re-treatment of a body lumen, comprising the steps of:

deploying to a region of said body lumen any stent of Claims 1, 21 or 42, wherein said stent is made from a bioresorbable polymer, and resides at said region for a period of time; and

administering to said region, after the period of time, a second treatment.

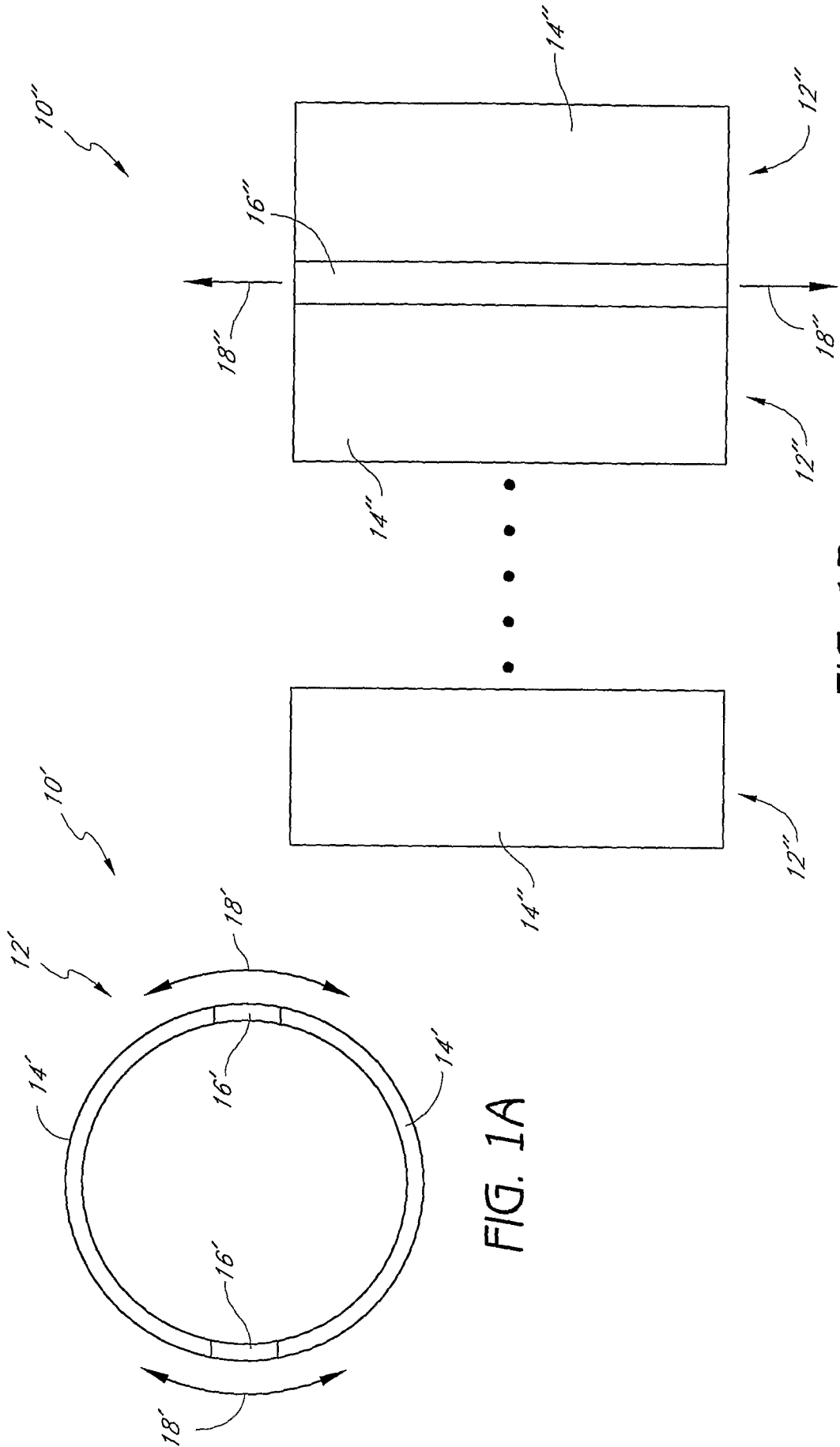

FIG. 1A

FIG. 1B

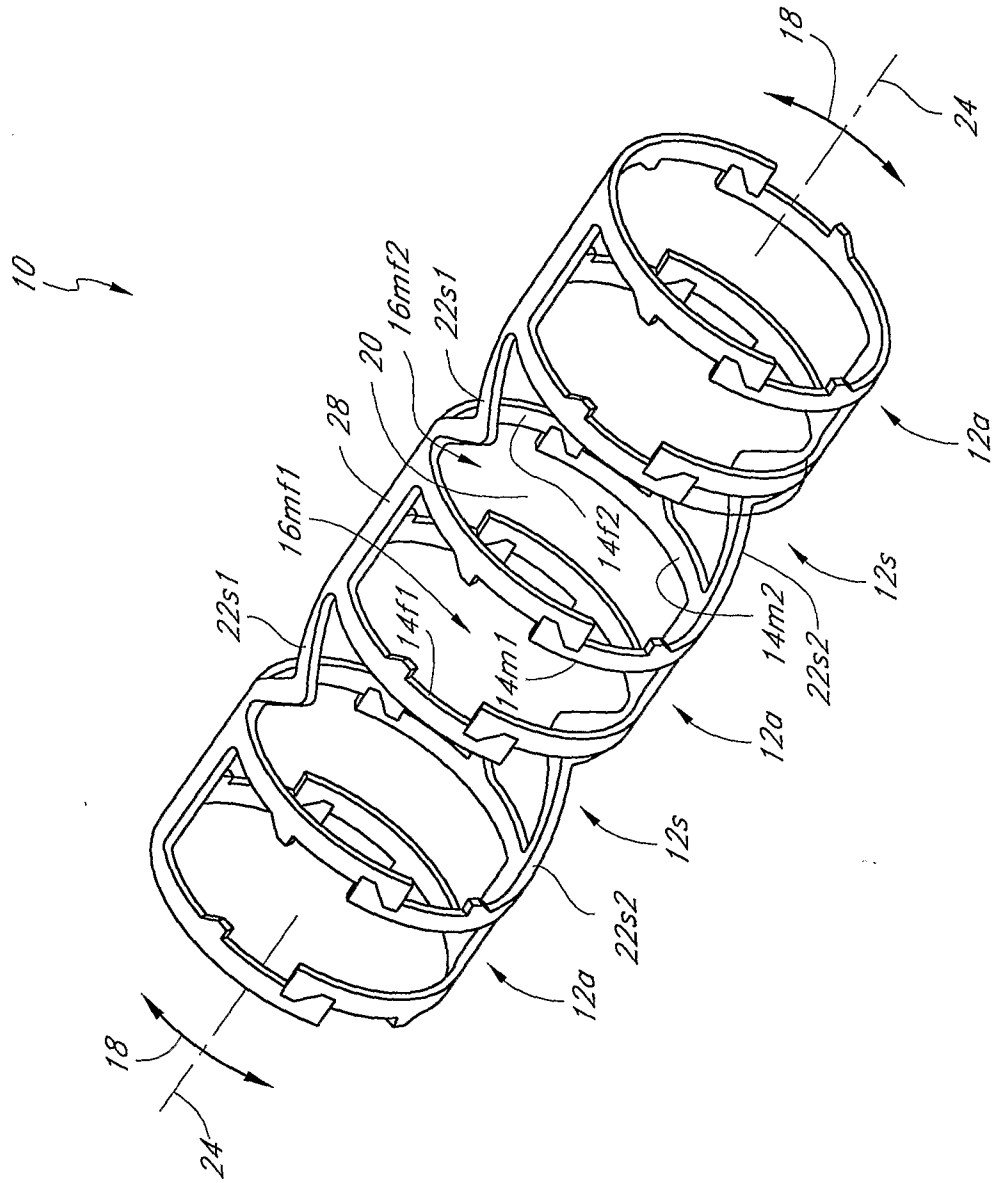

FIG. 2

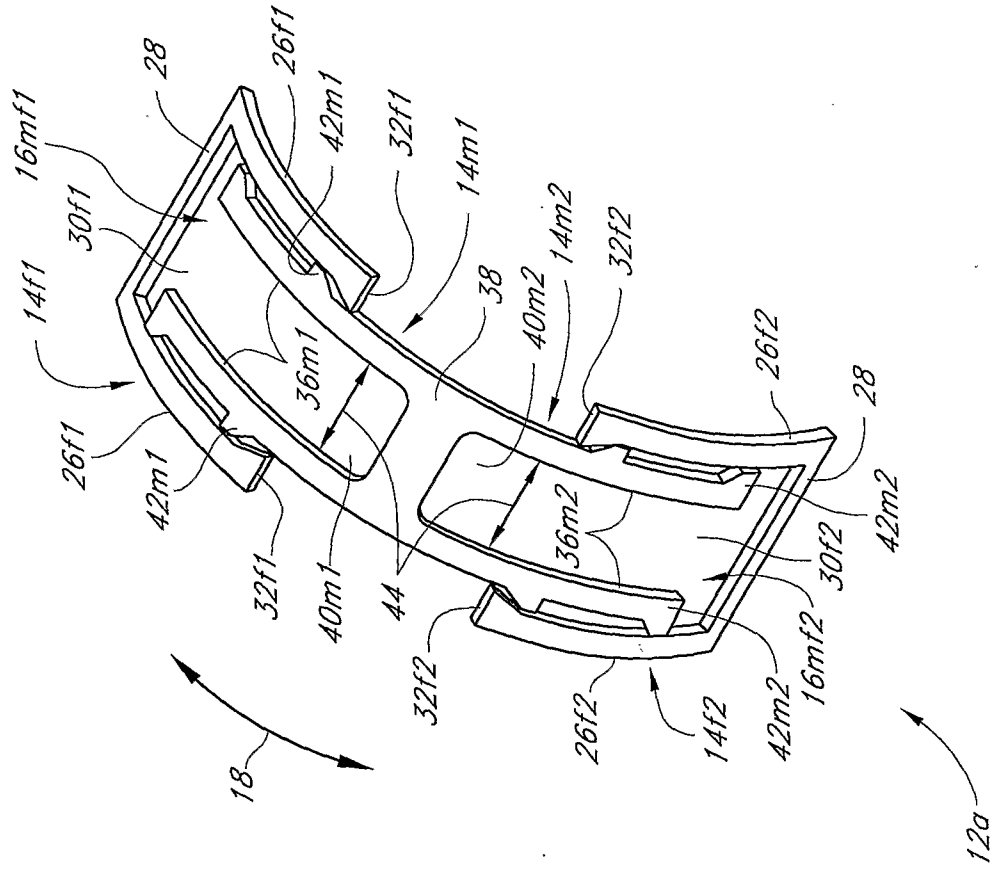

FIG. 3

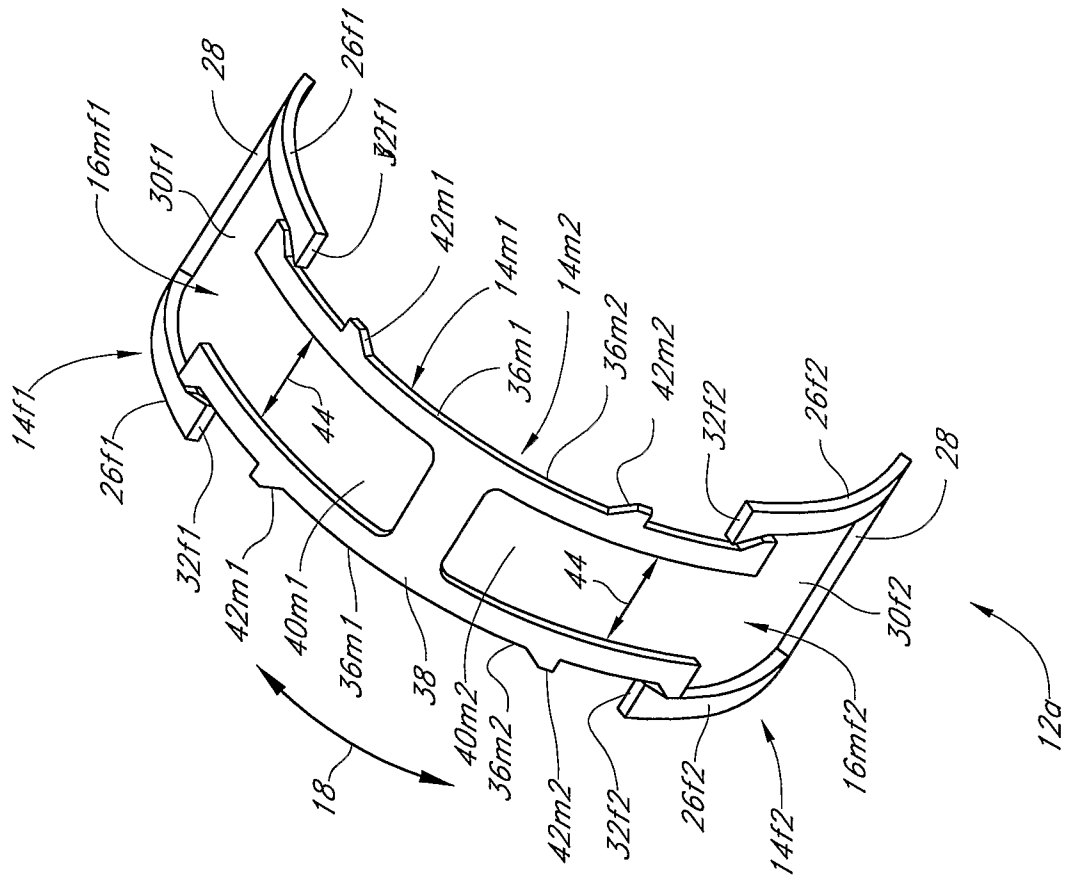

FIG. 4

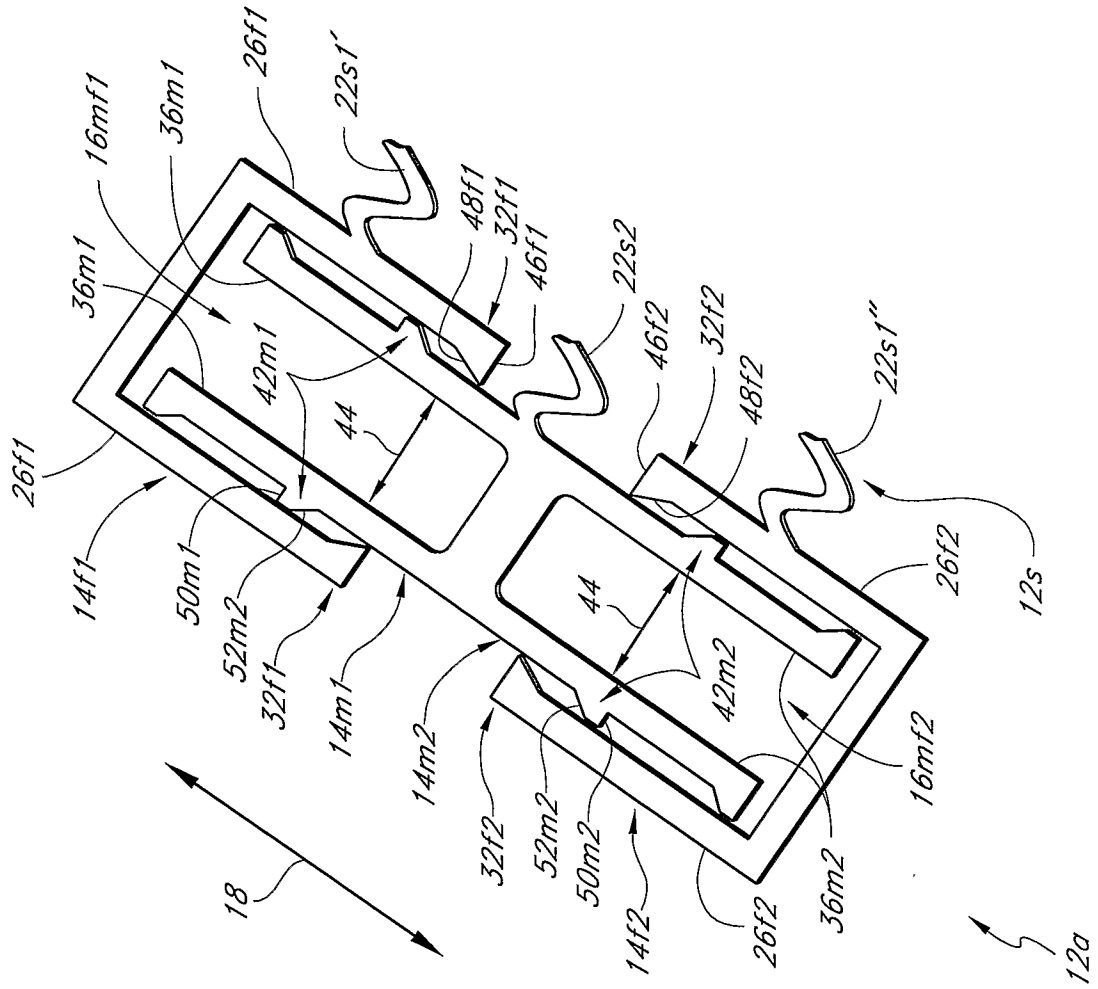

FIG. 5

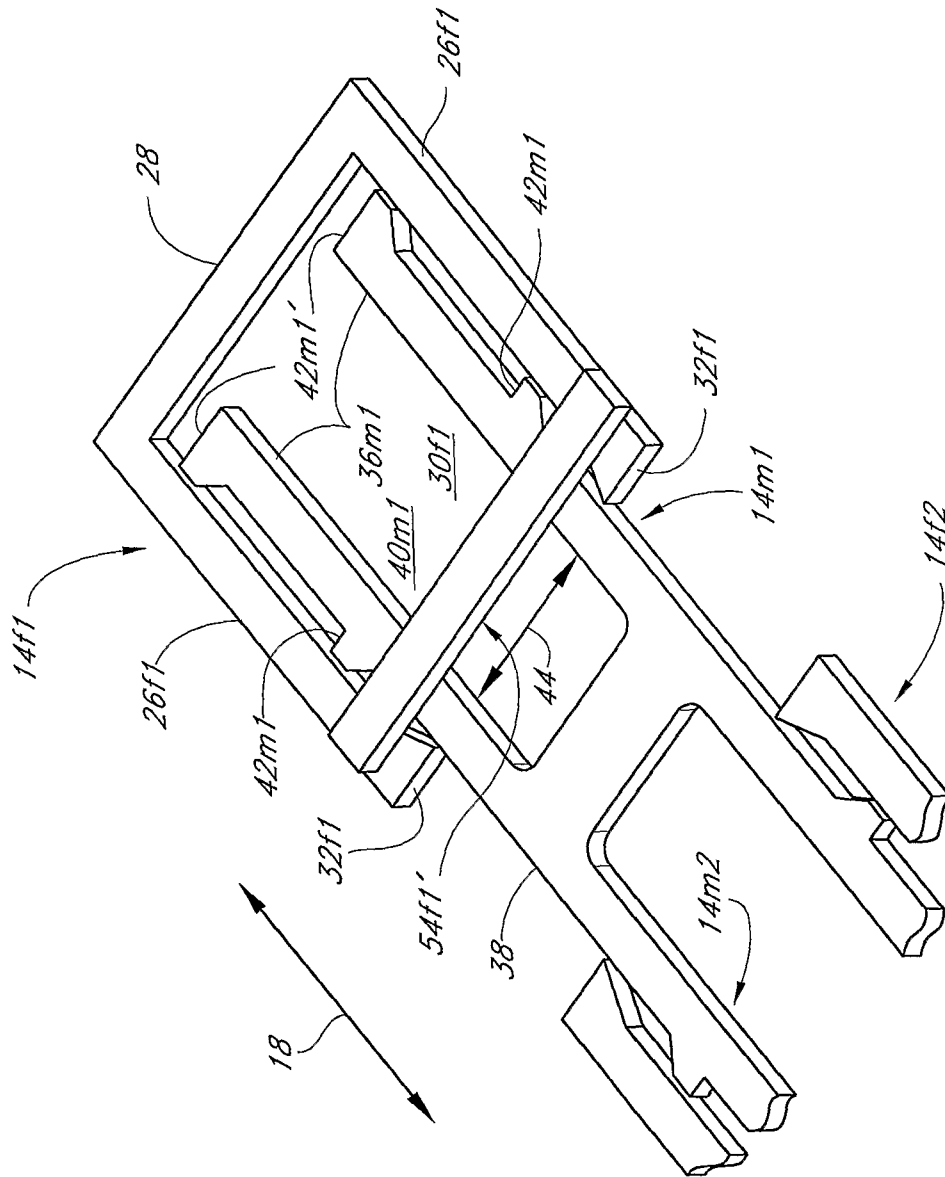

FIG. 6
12a

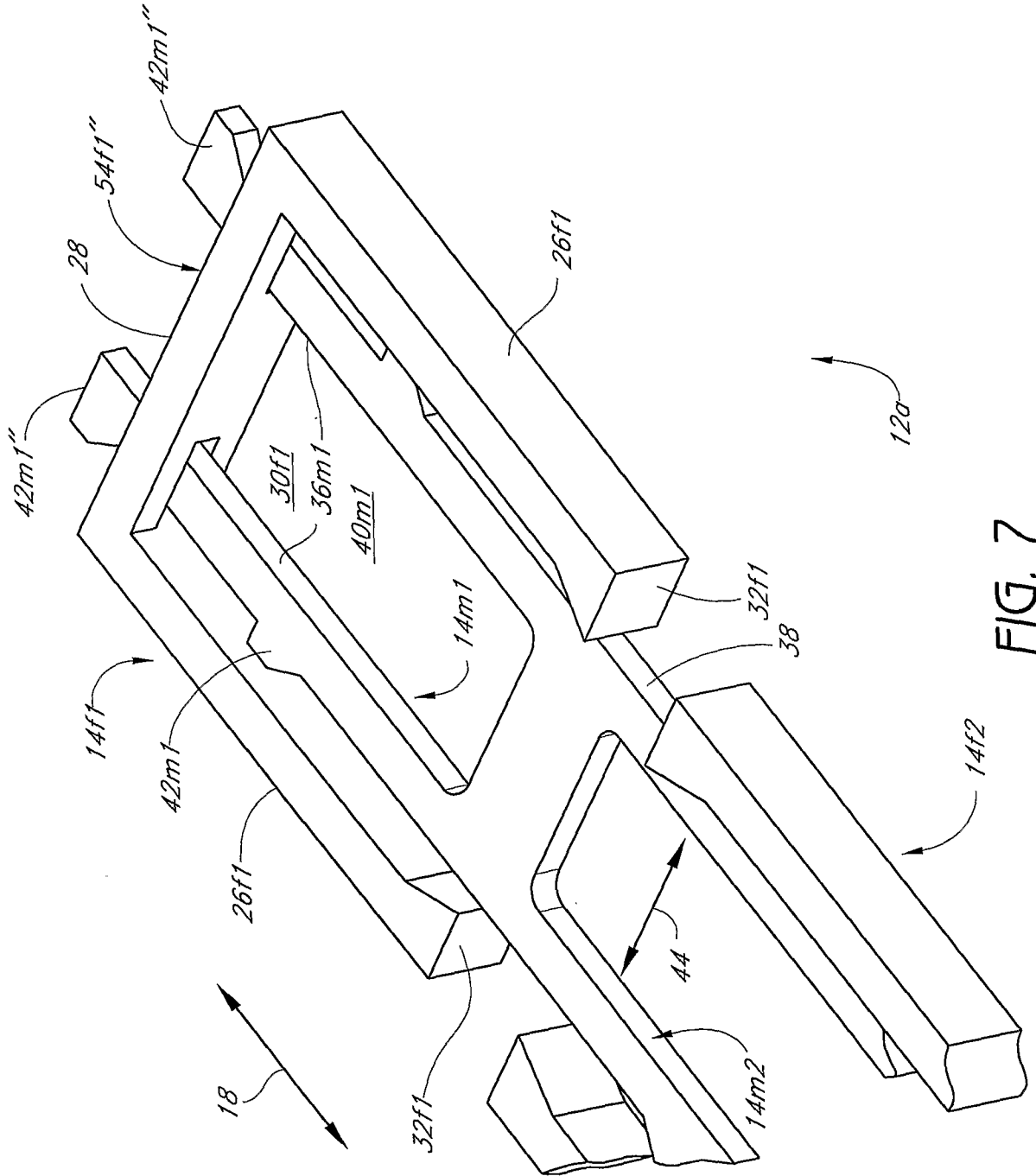

FIG. 7

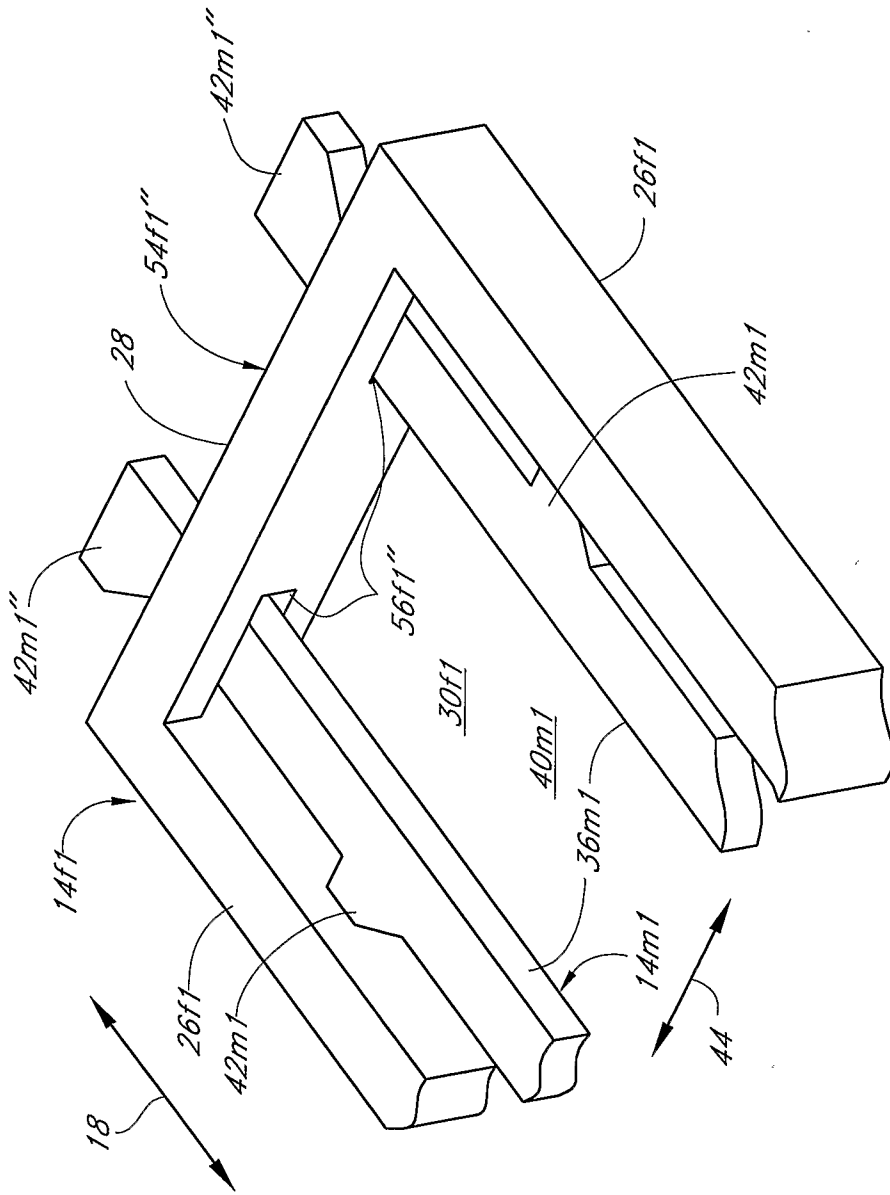

FIG. 8

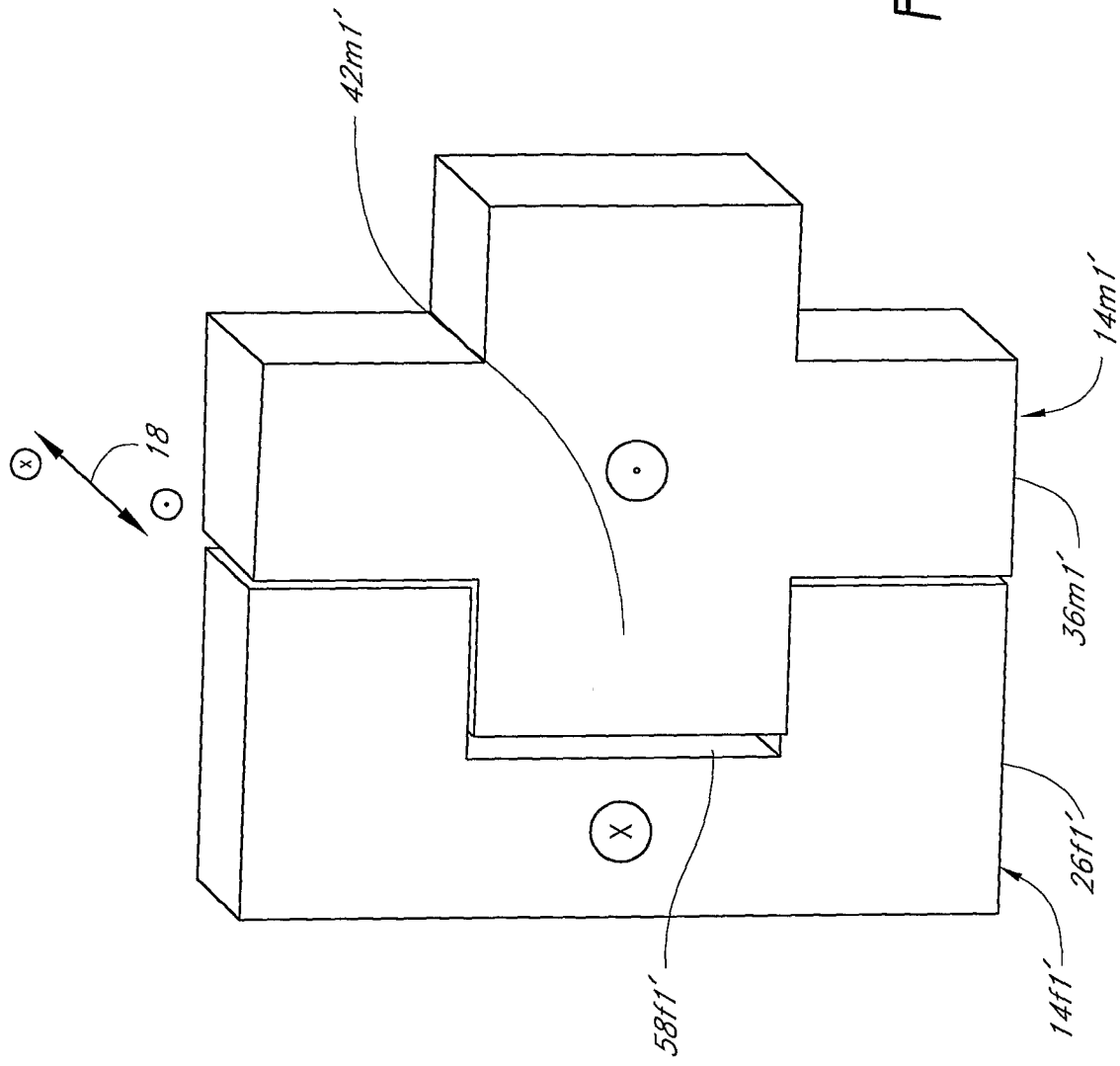

FIG. 9

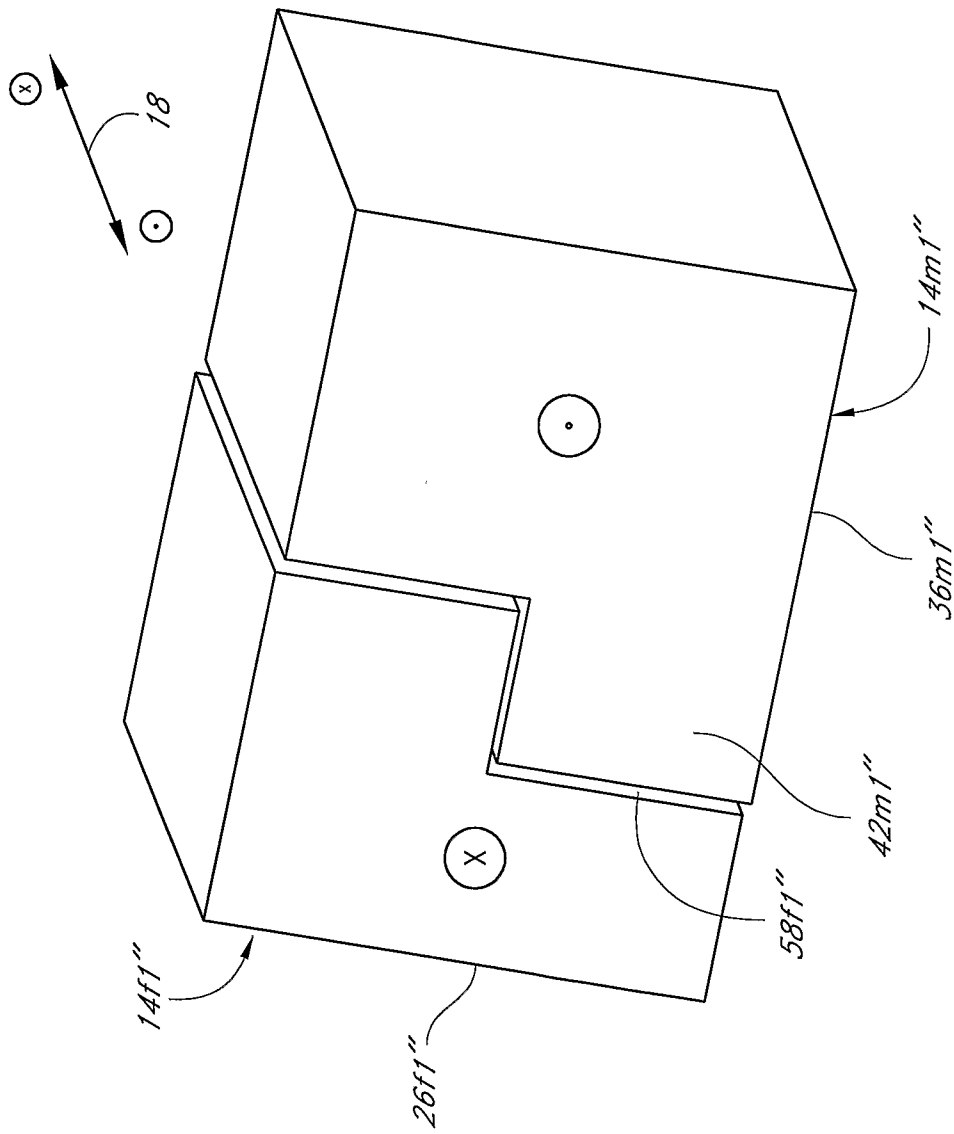

FIG. 10

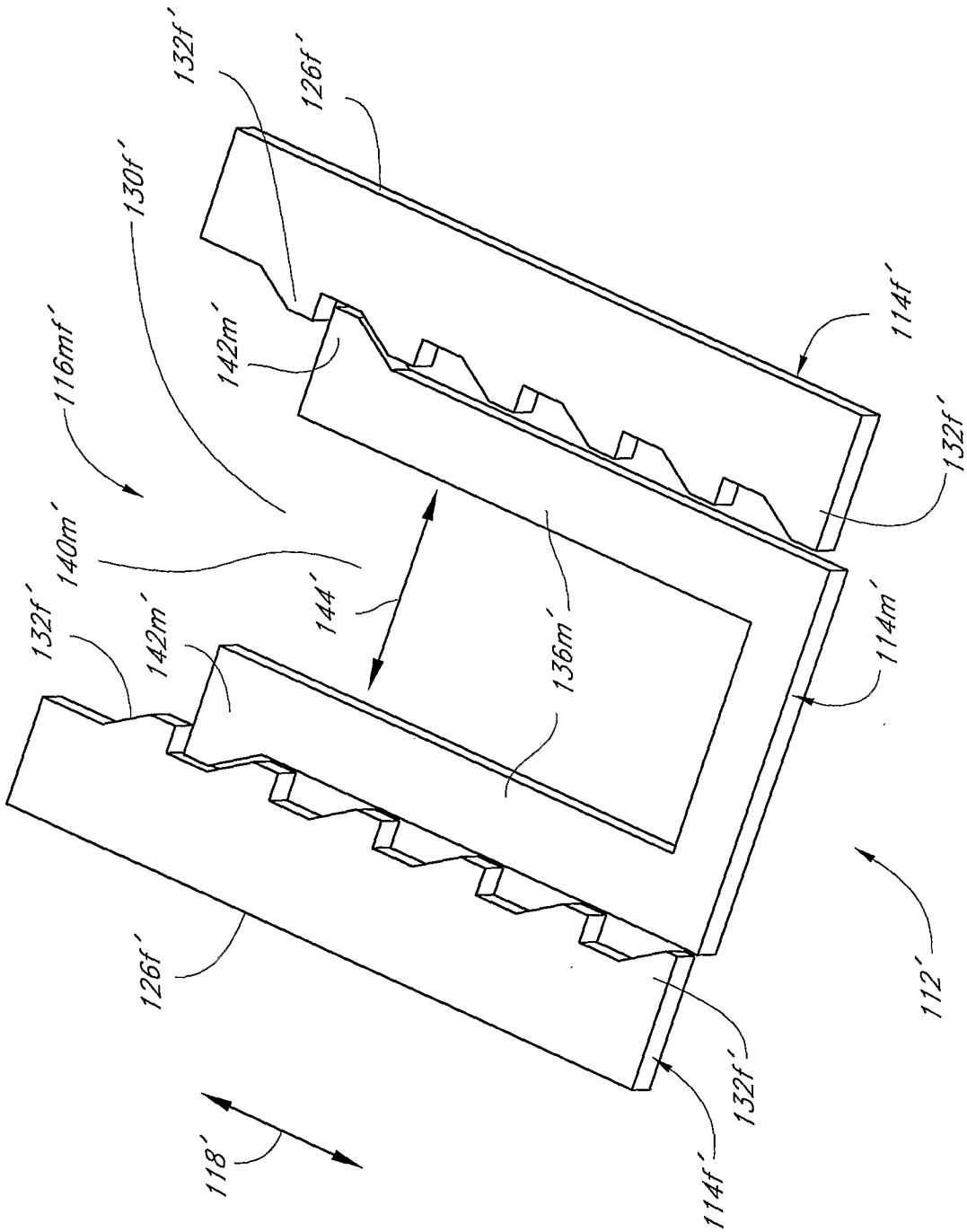

FIG. 11

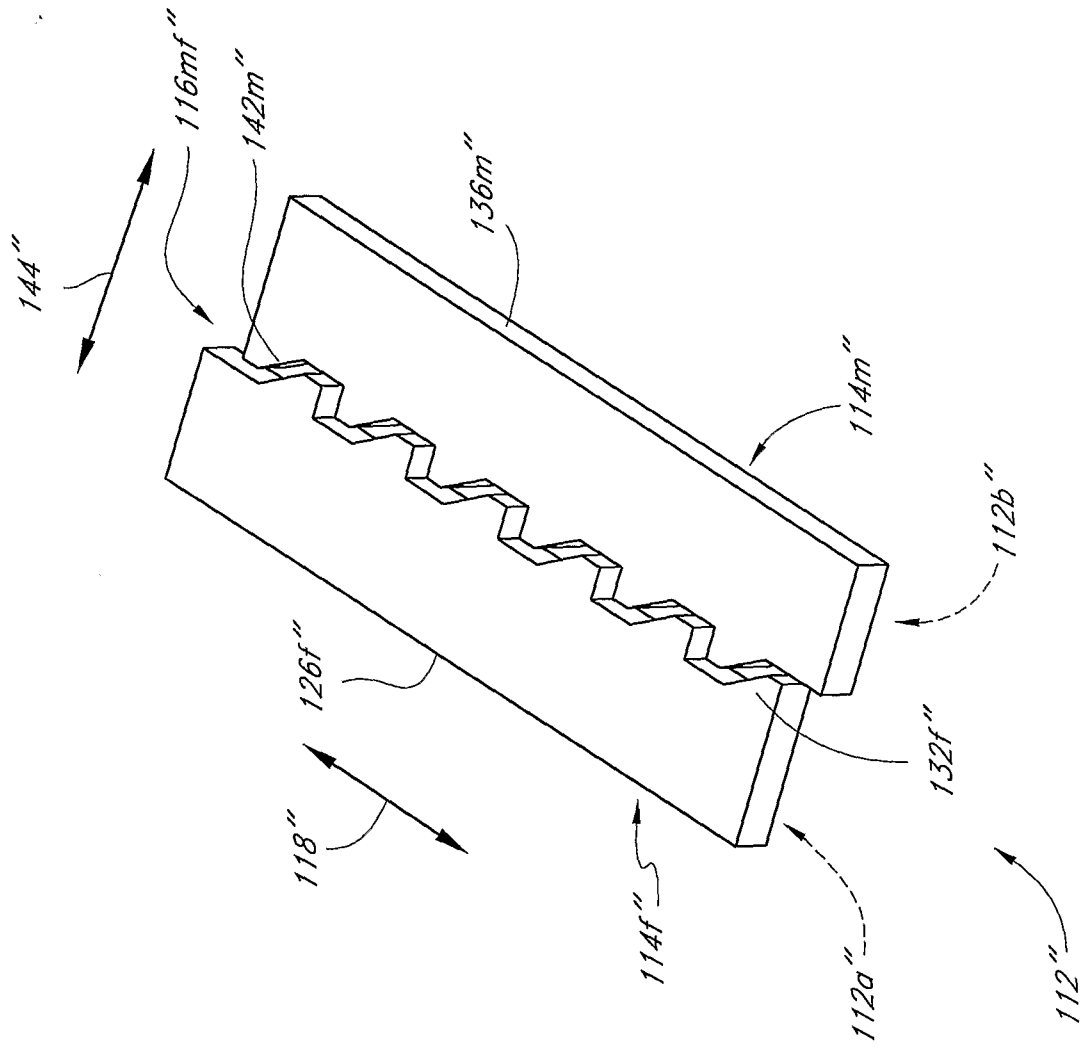

FIG. 12

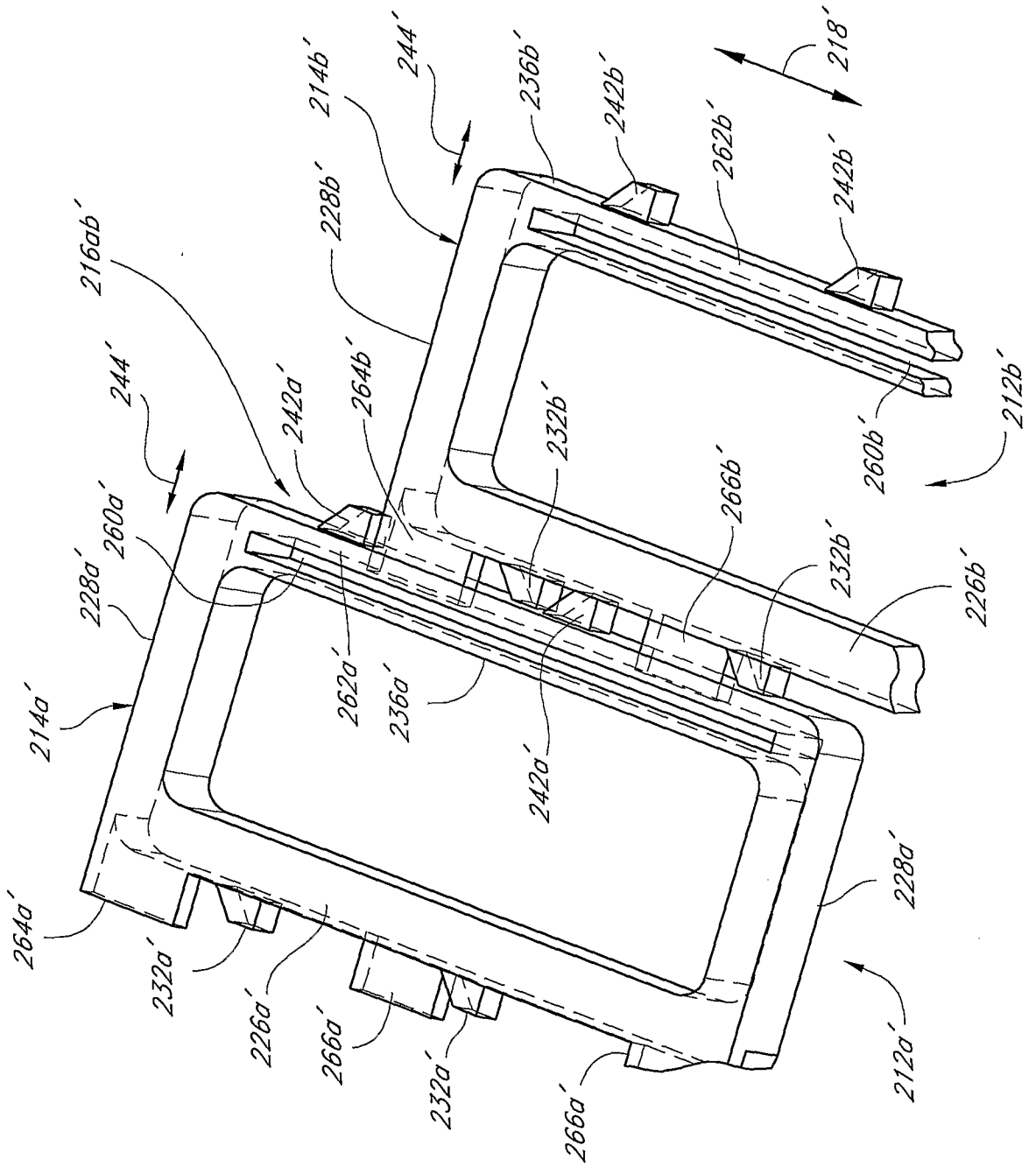

FIG. 13A

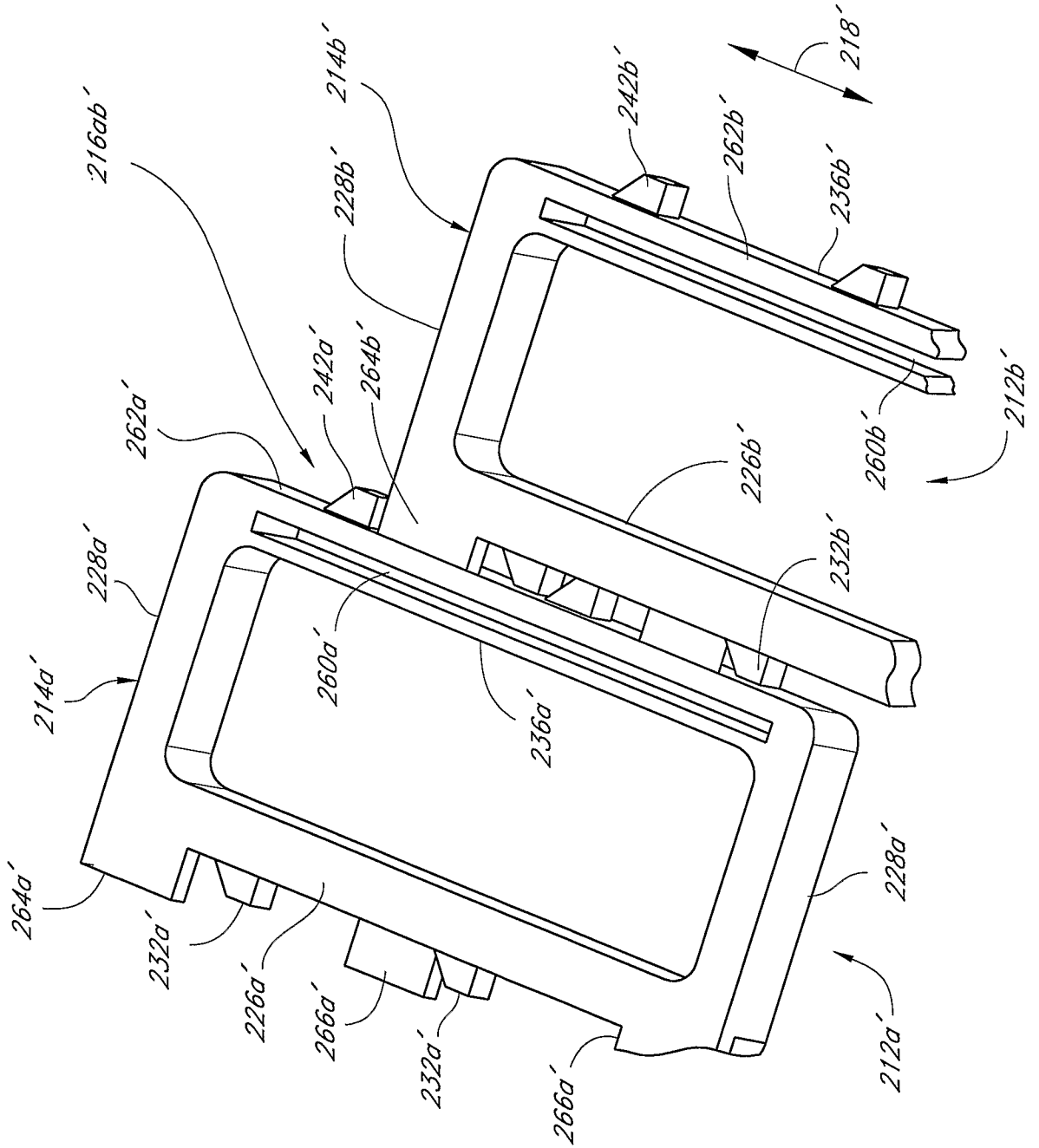

FIG. 13B

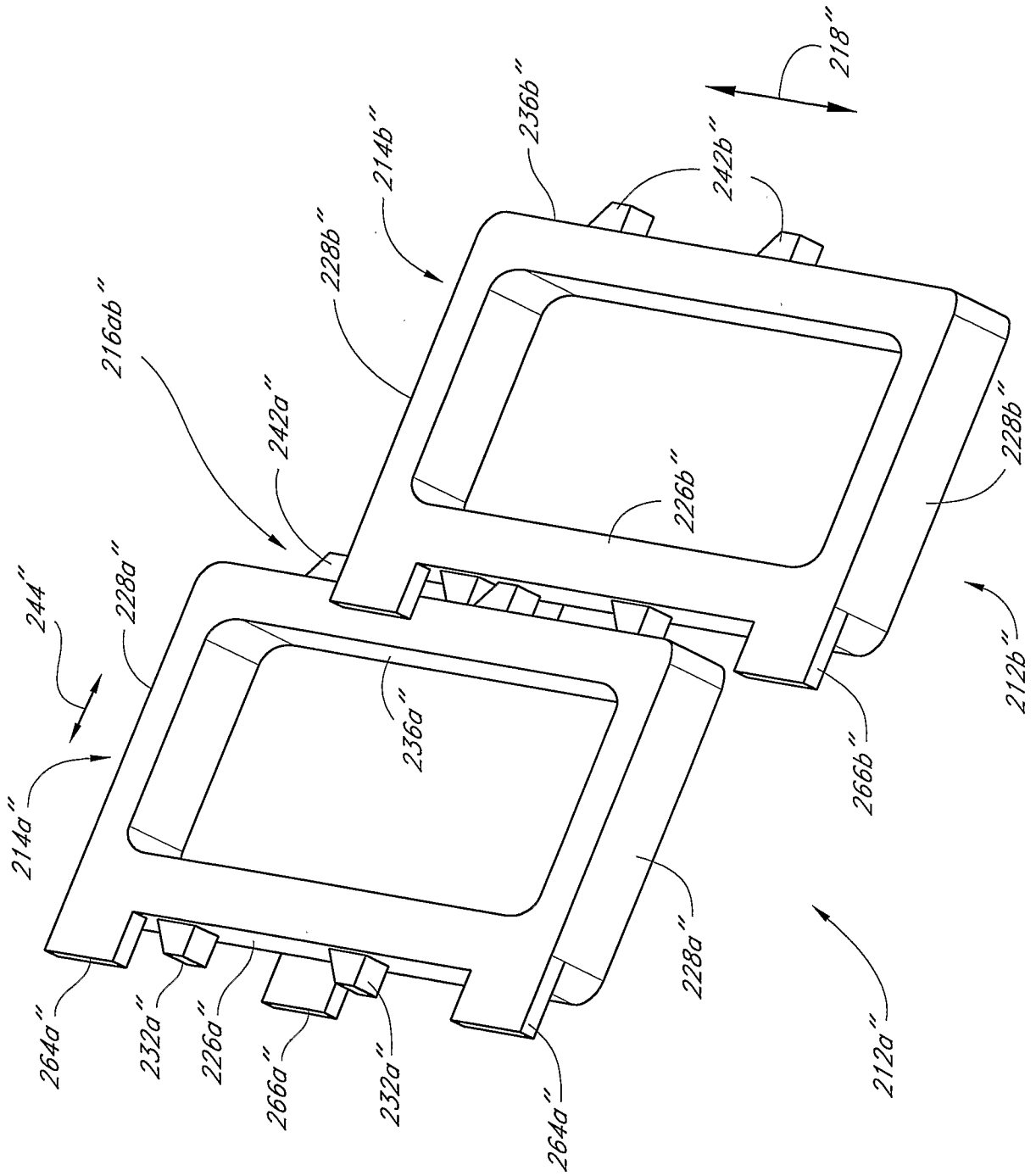

FIG. 14B

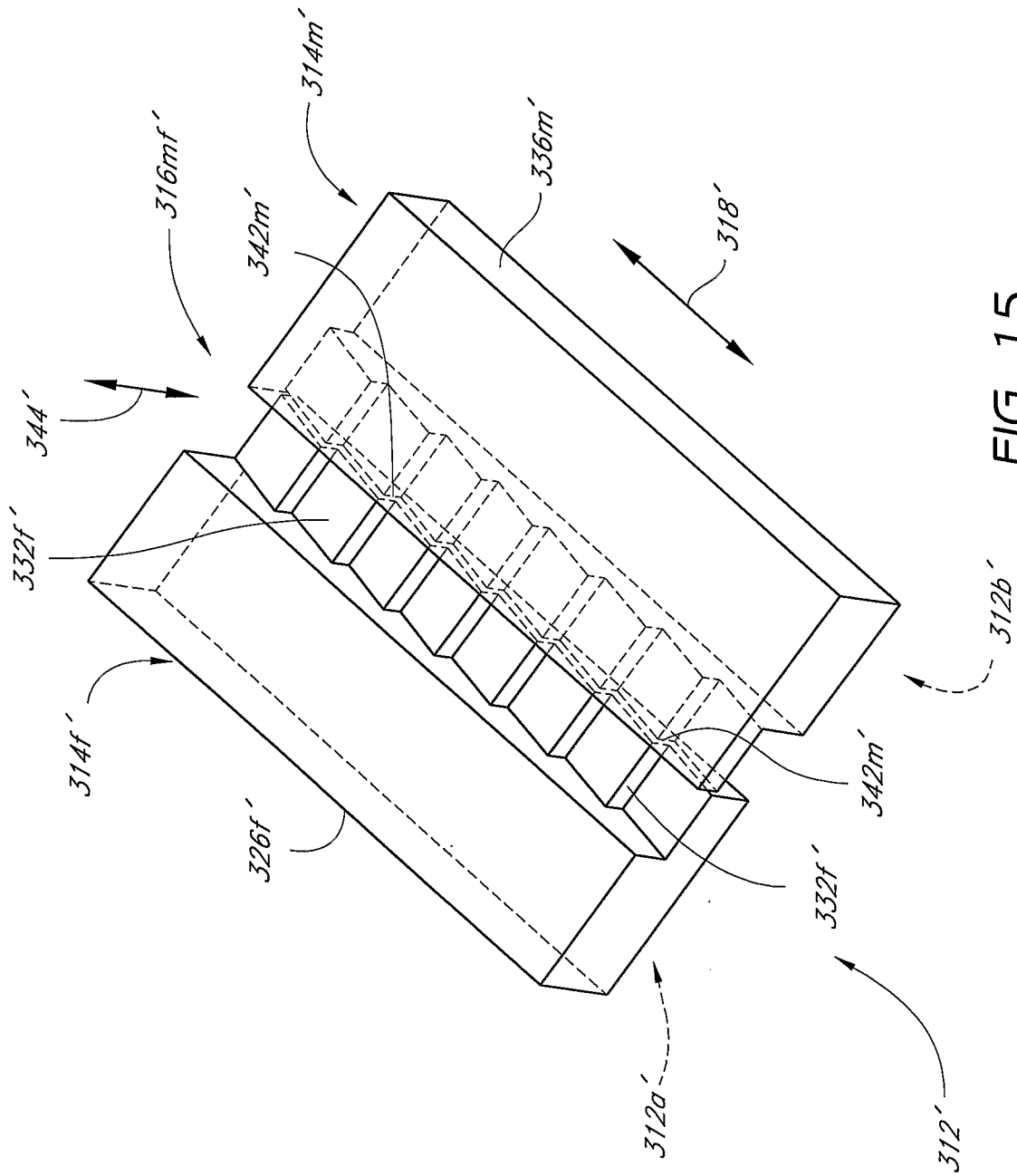

FIG. 15

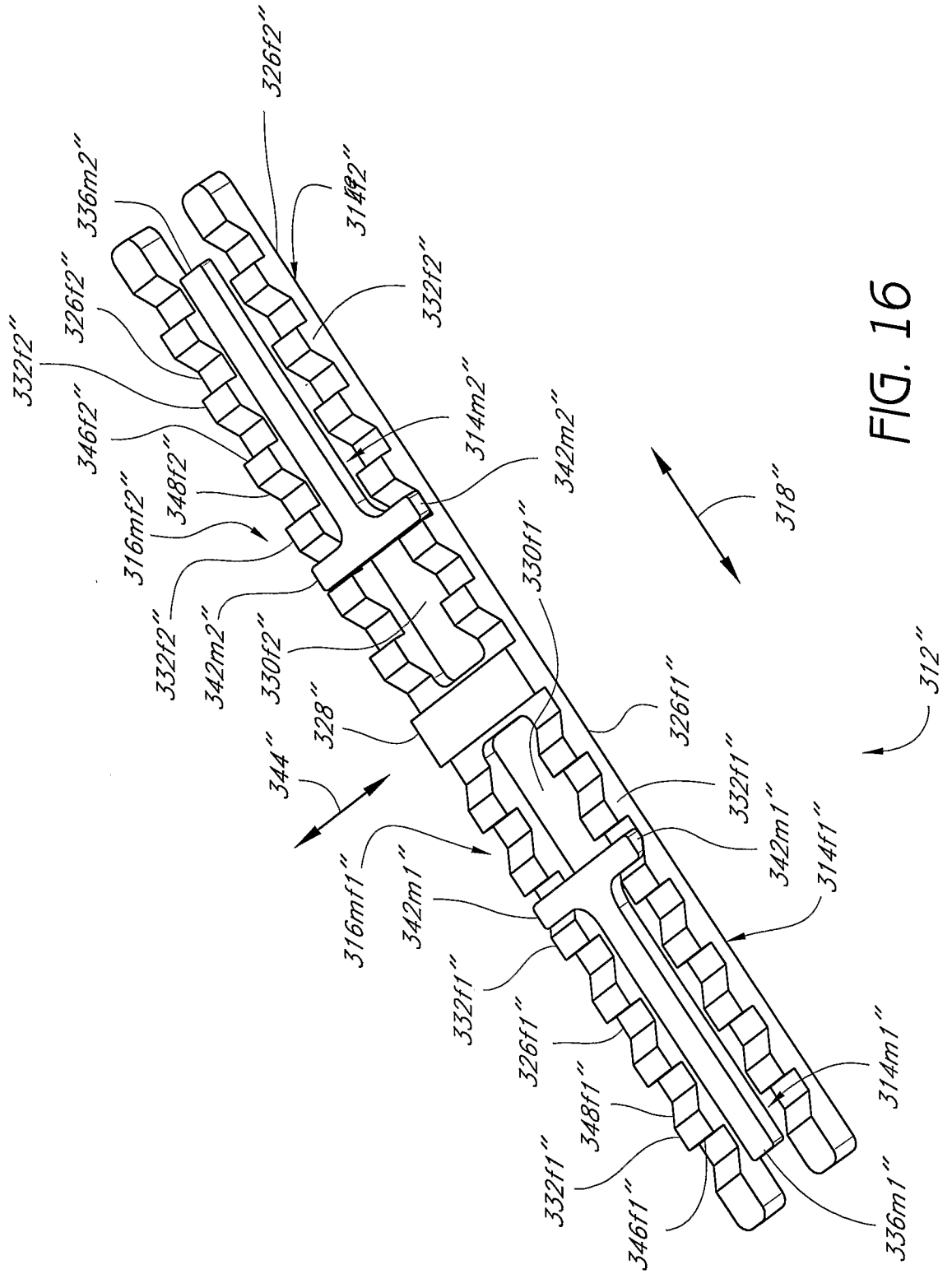

FIG. 16

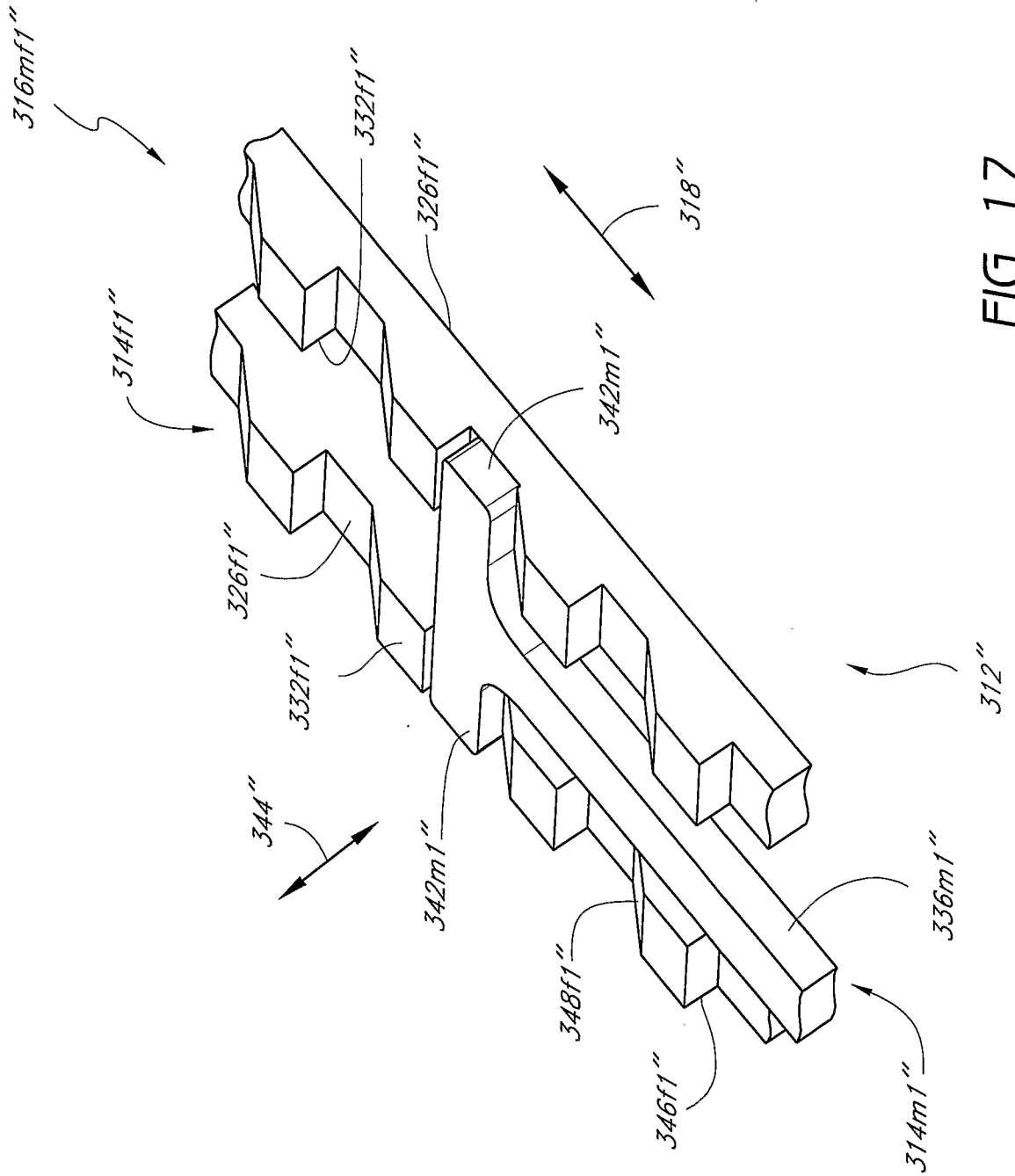

FIG. 17

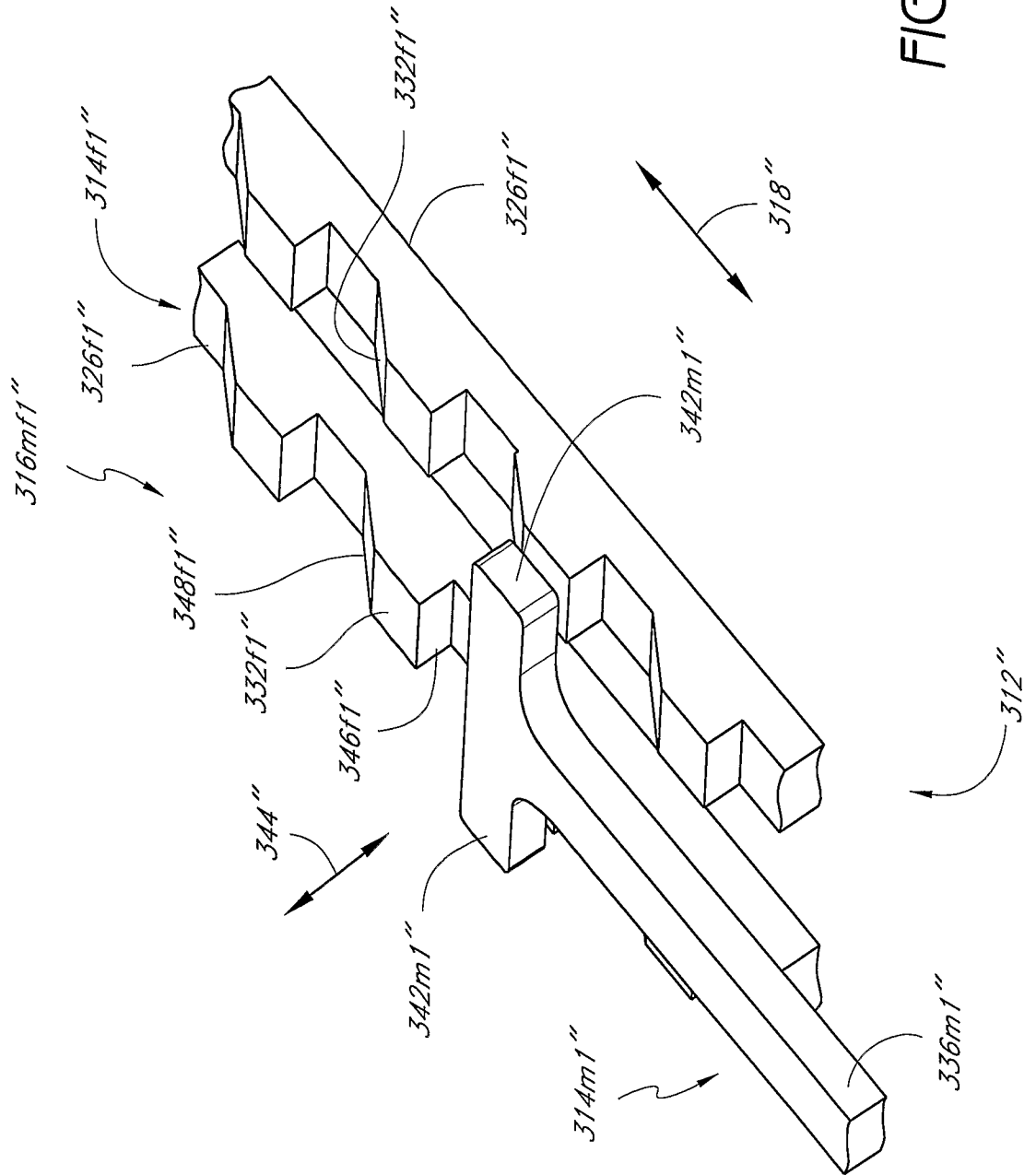

FIG. 18

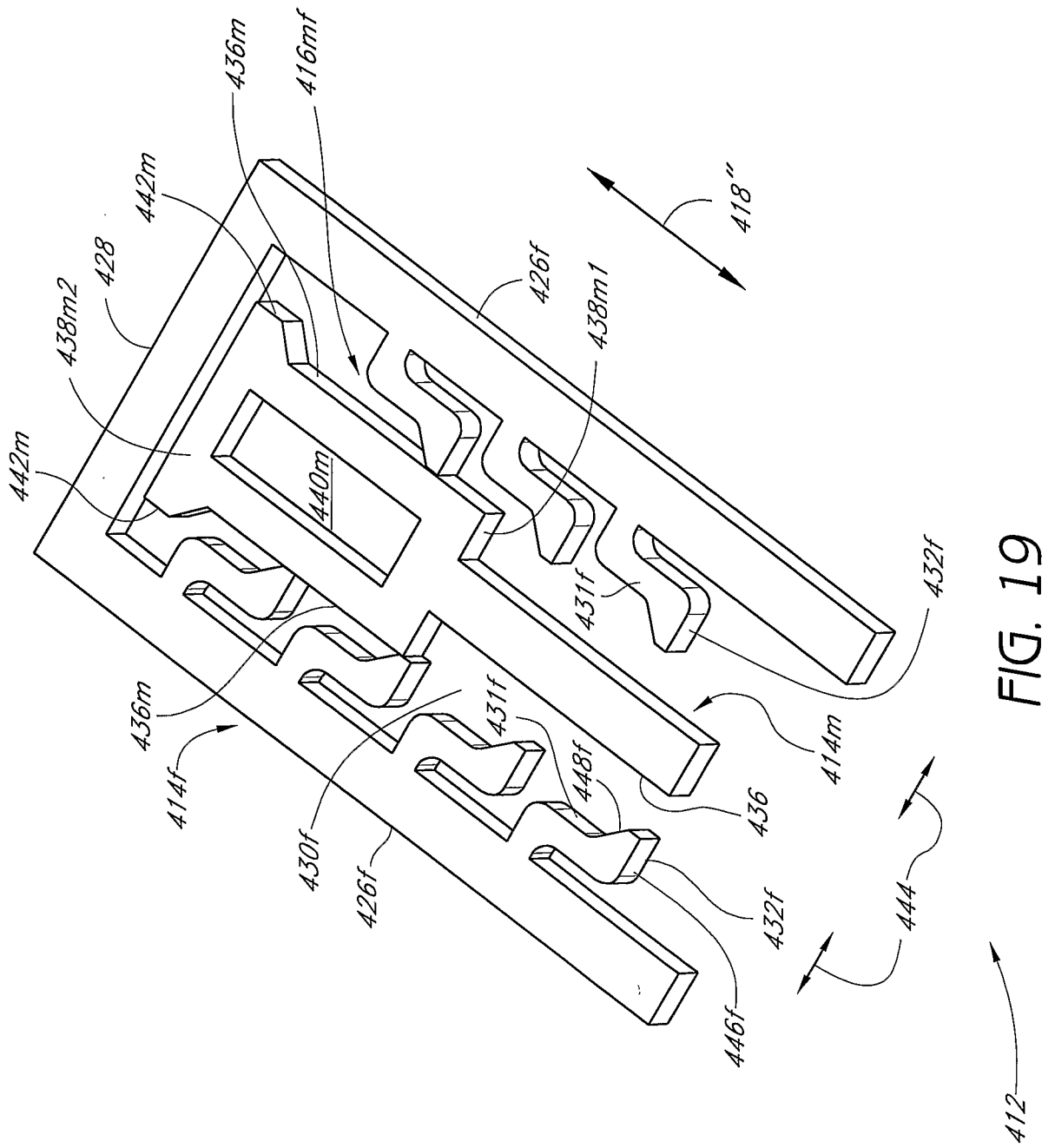

FIG. 19

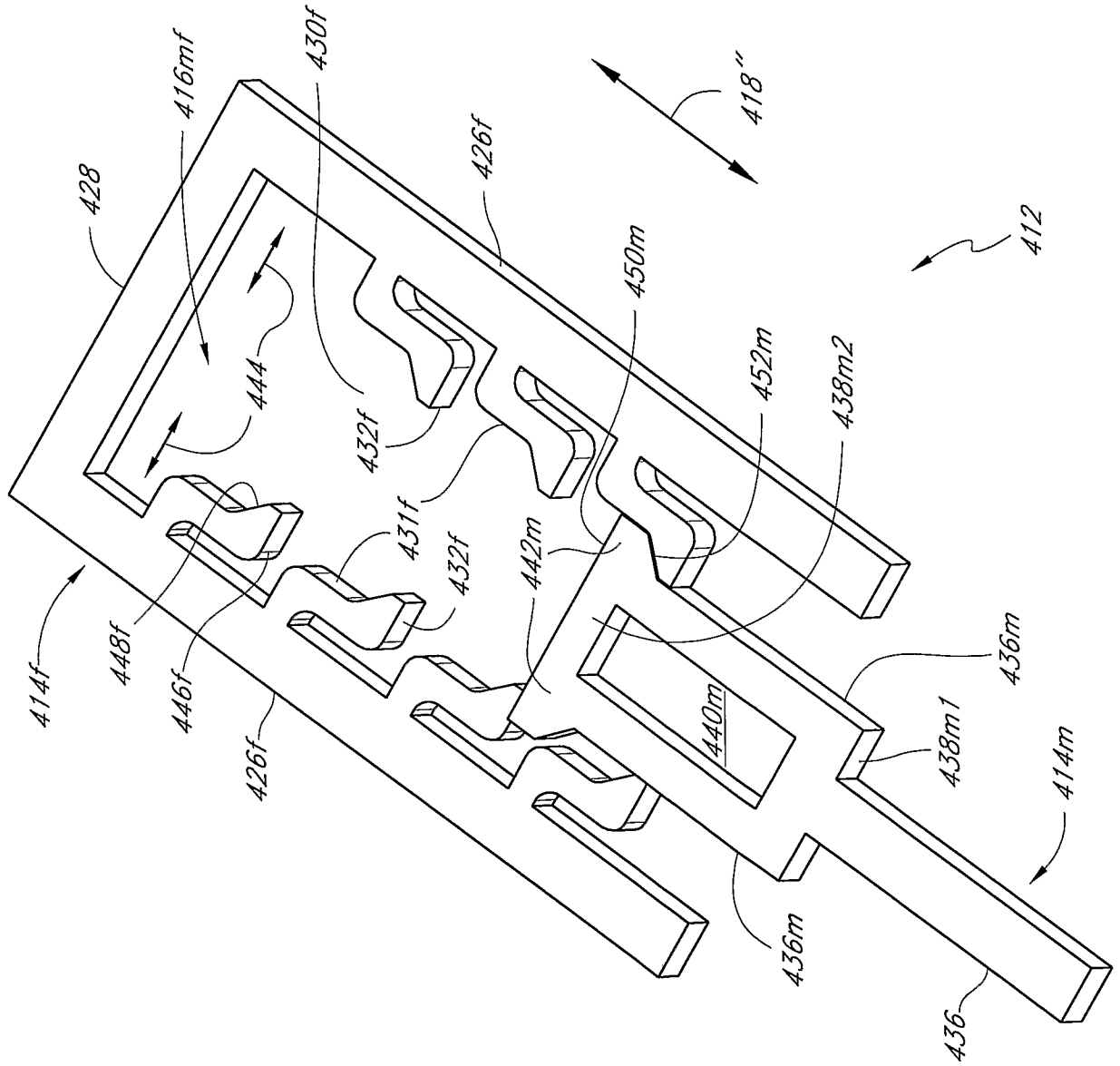
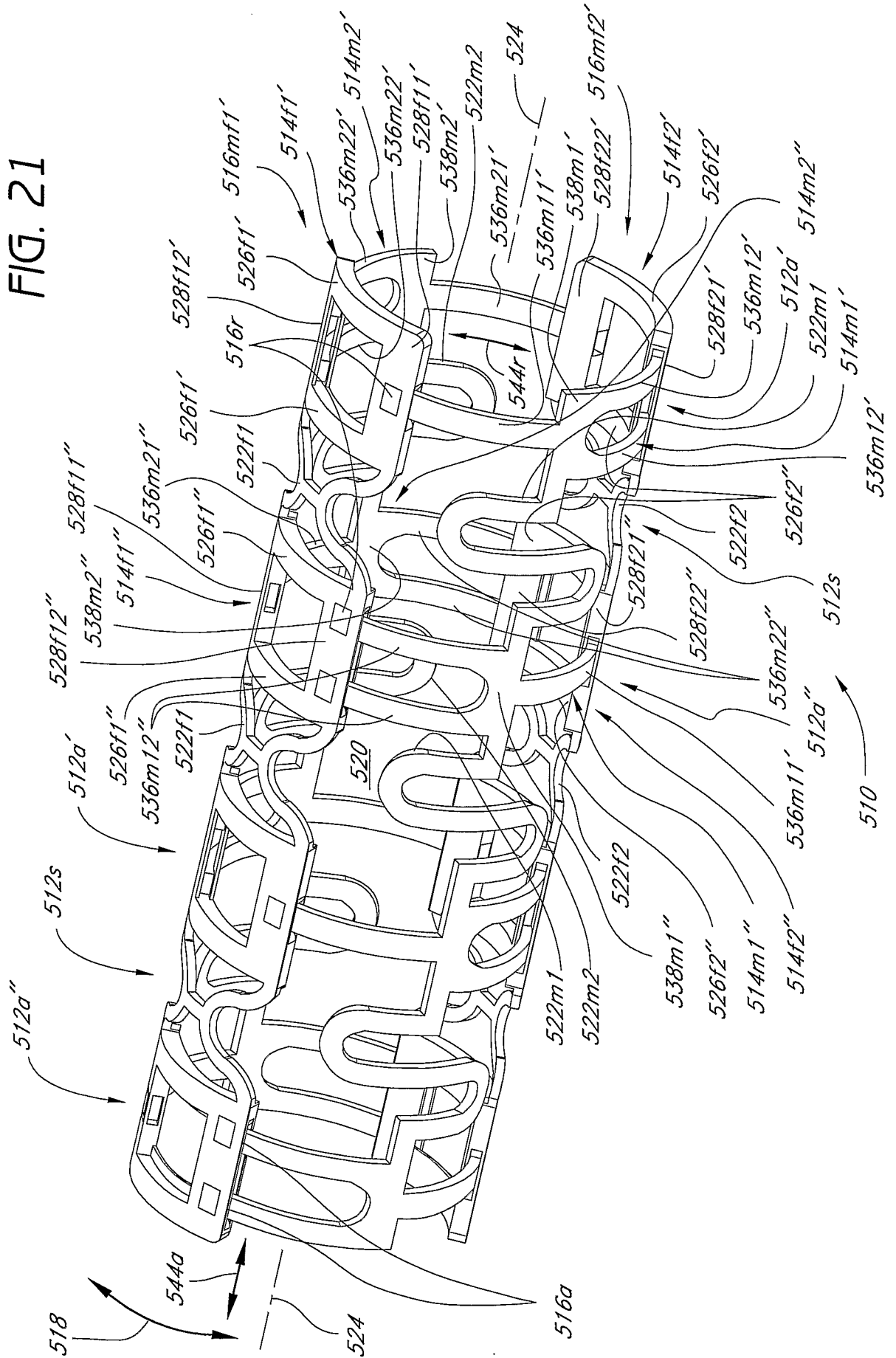

FIG. 20

FIG. 21



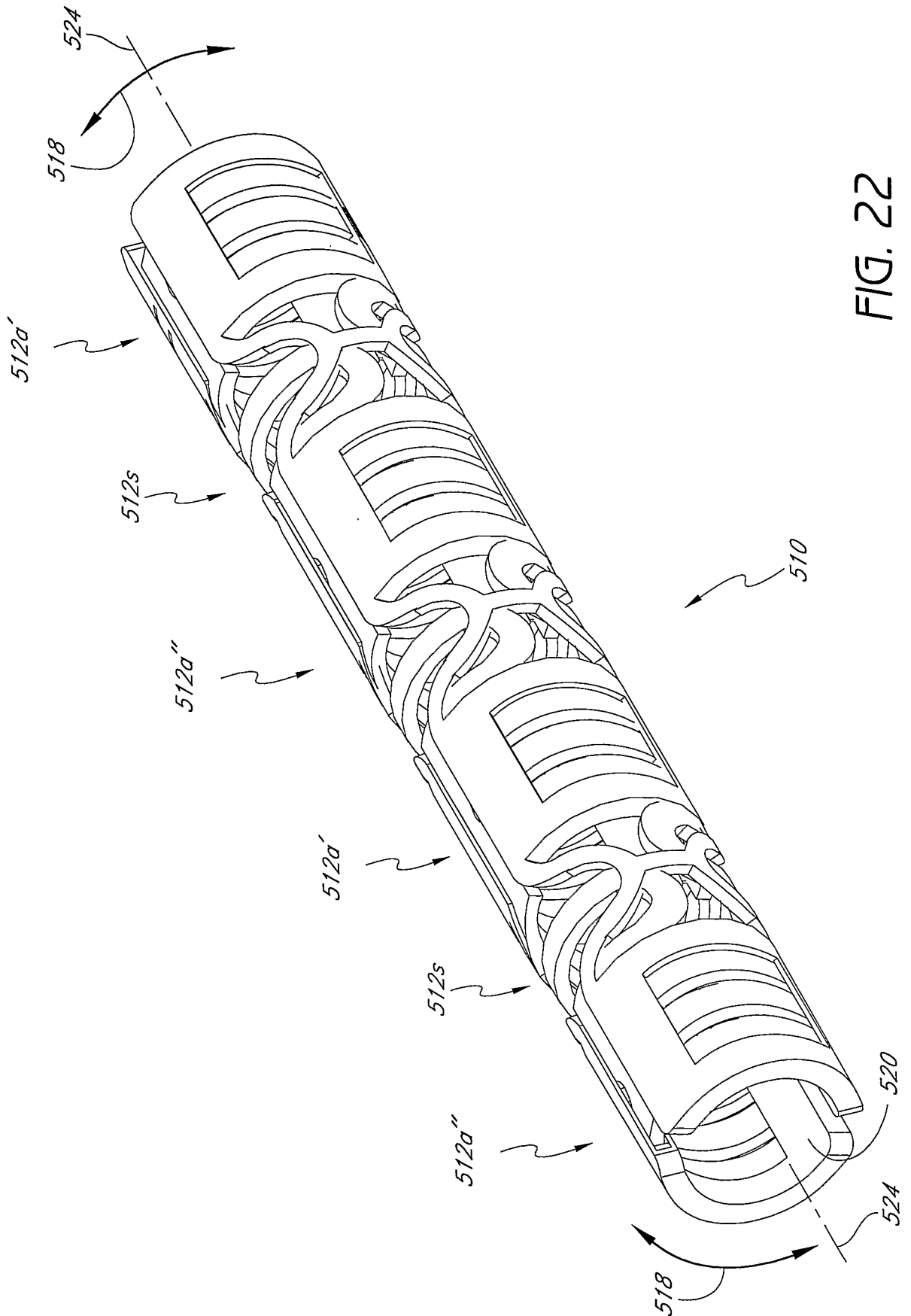

FIG. 22

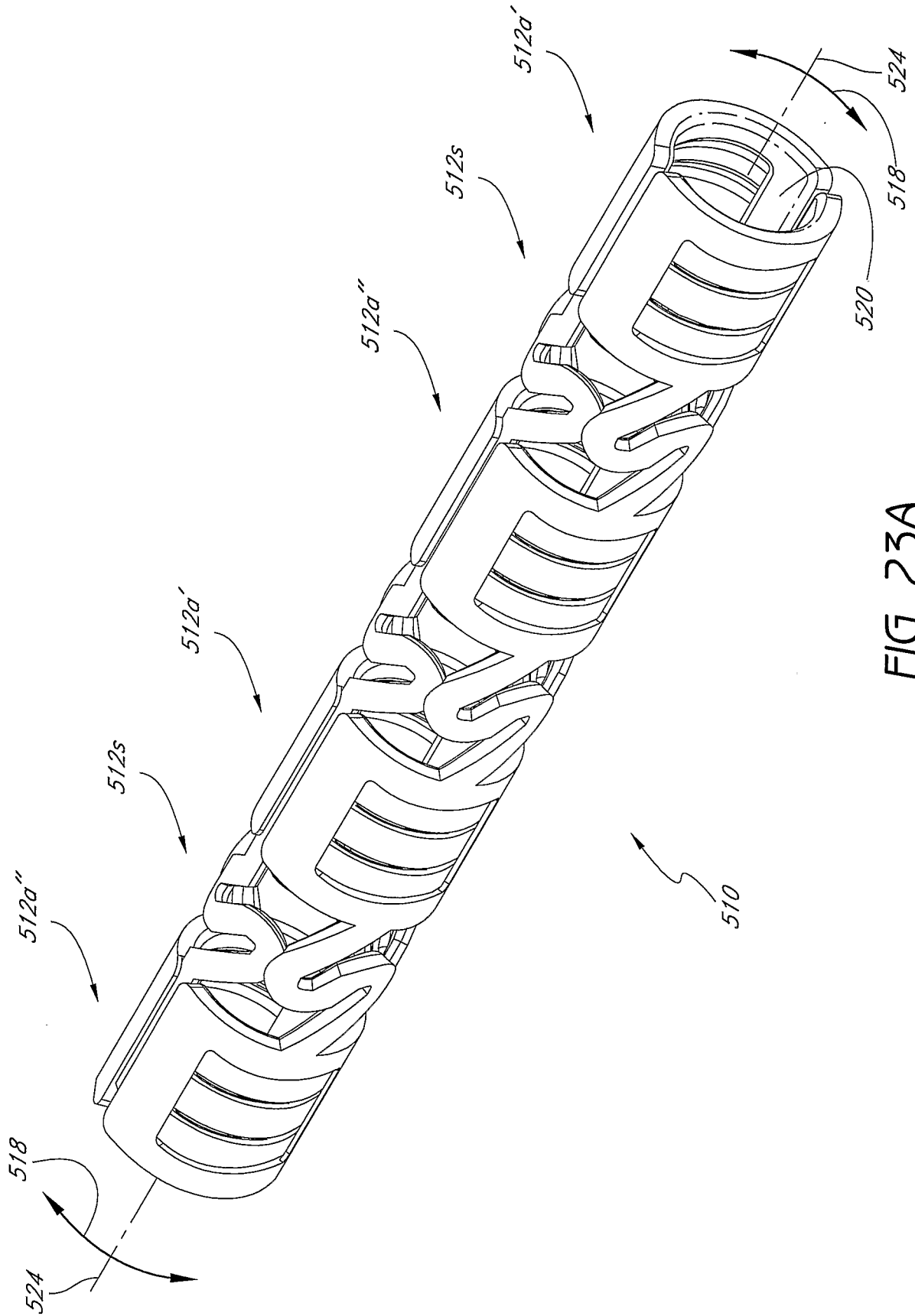

FIG. 23A

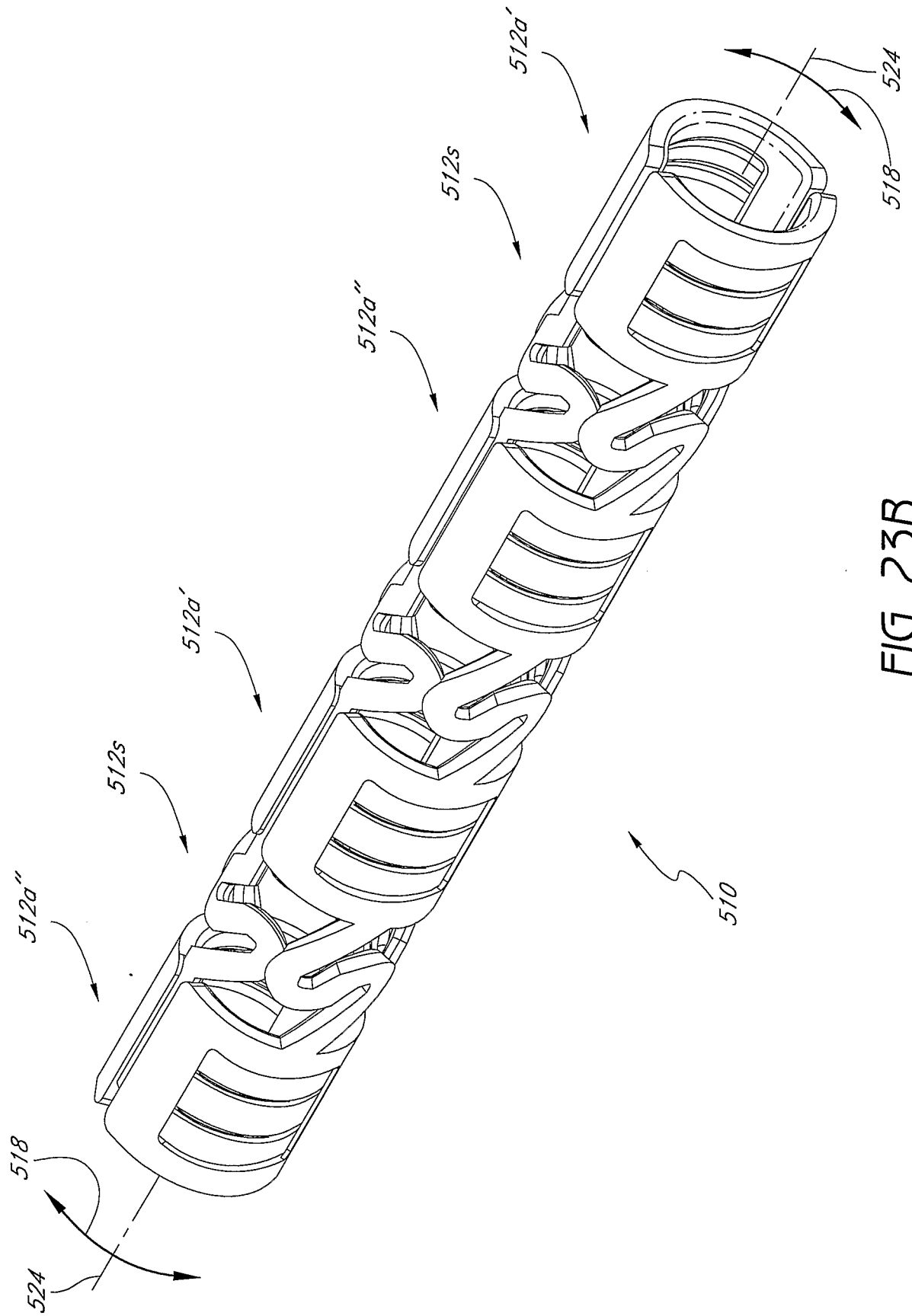

FIG. 23B

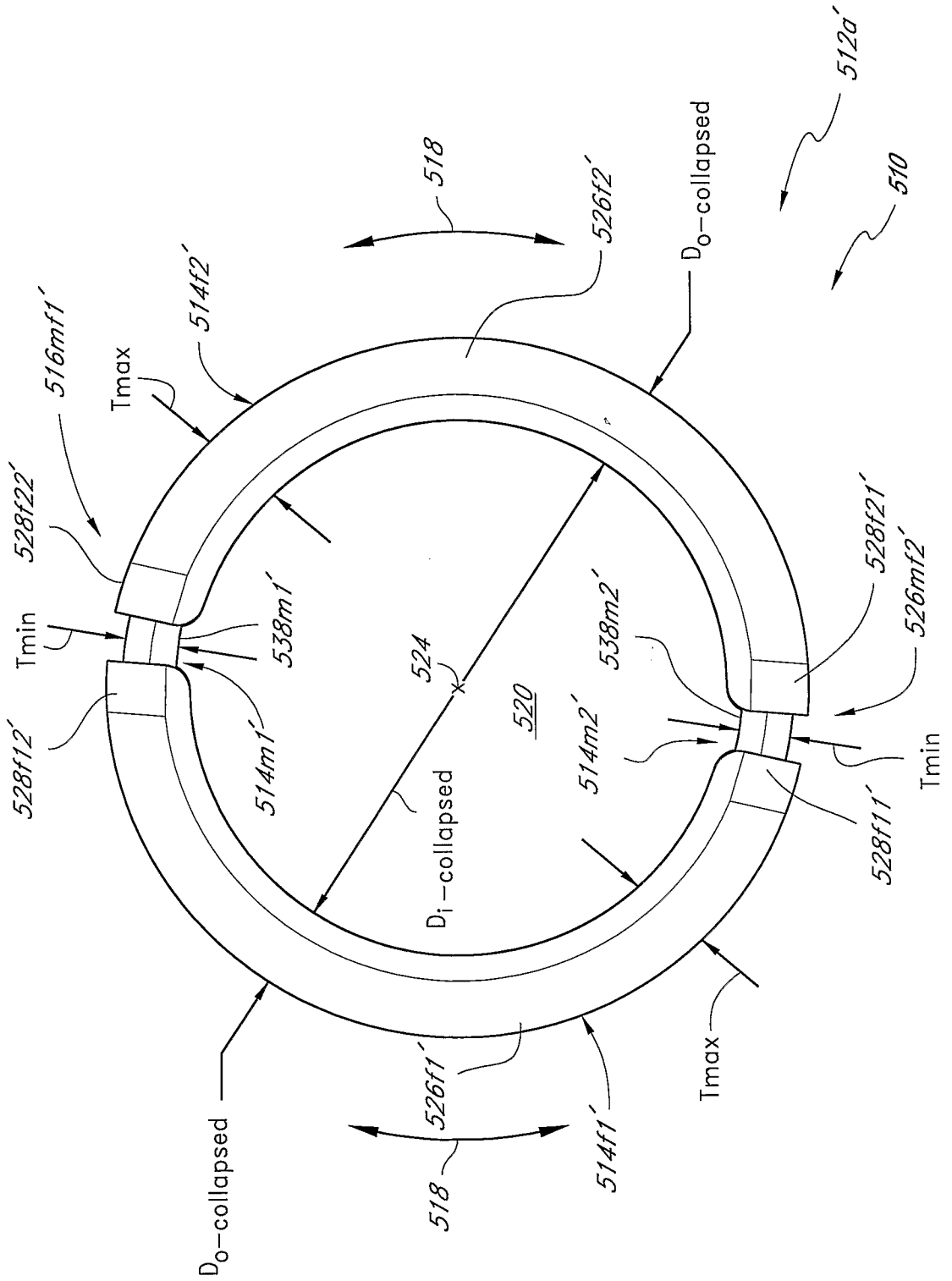

FIG. 24

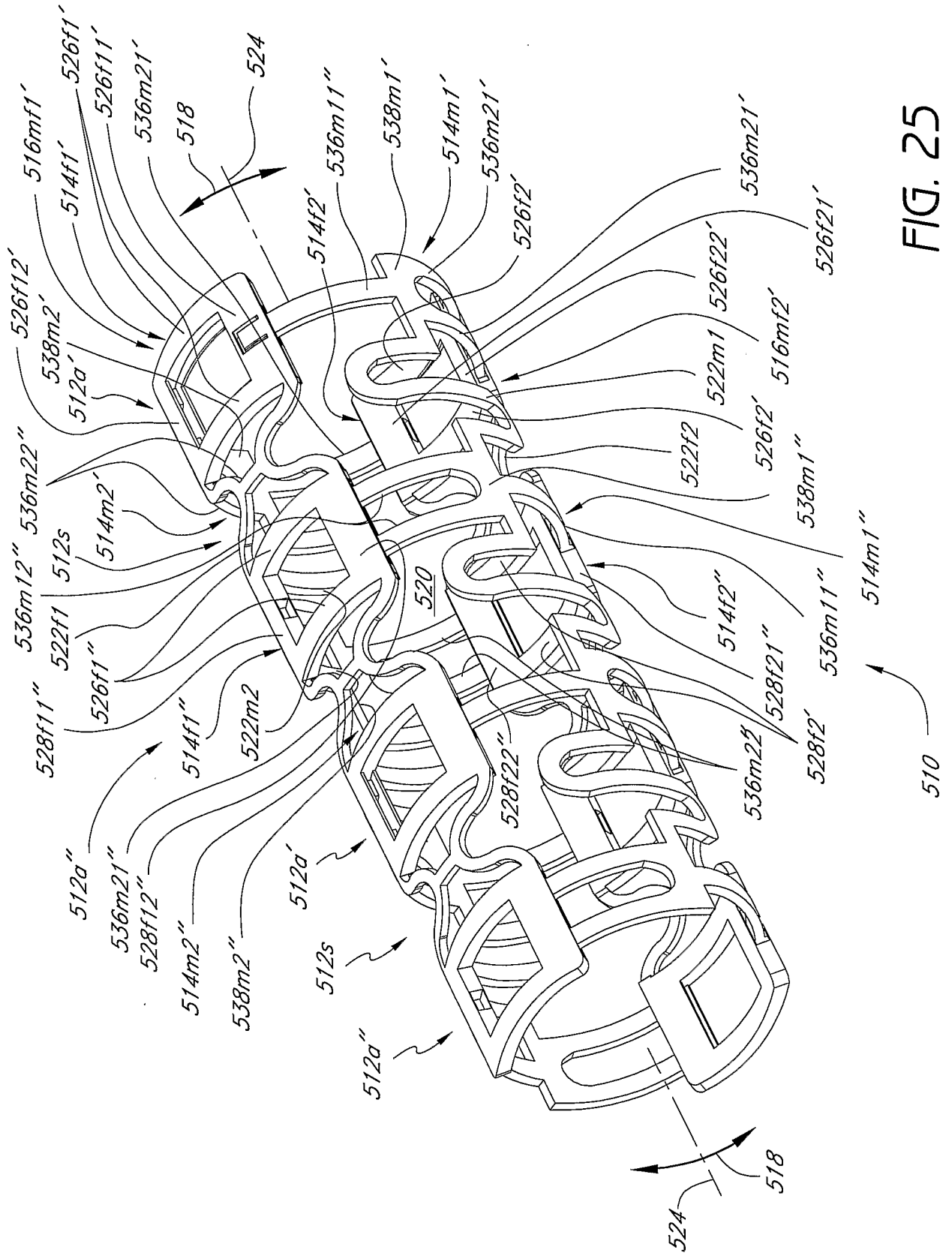

FIG. 25

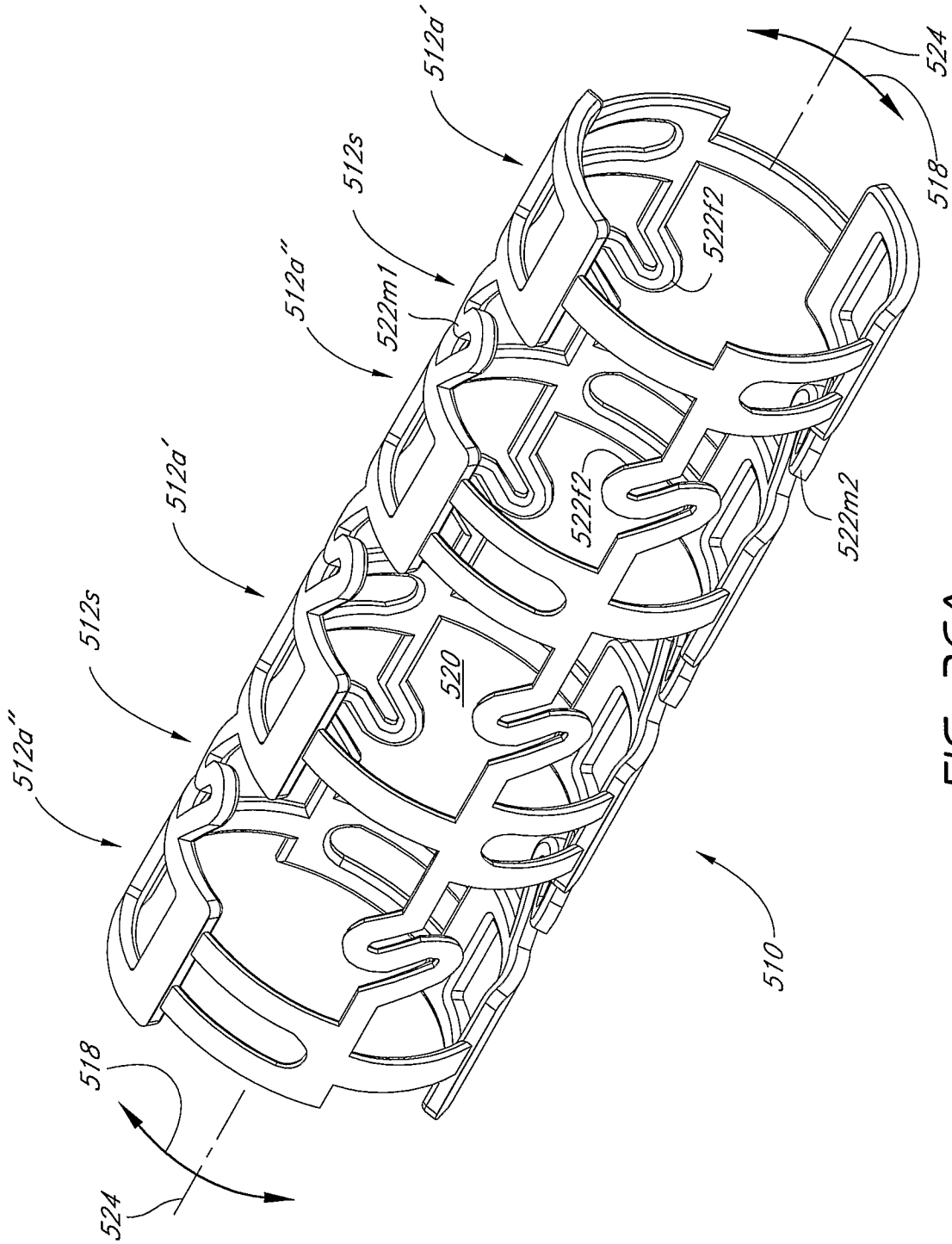

FIG. 26A

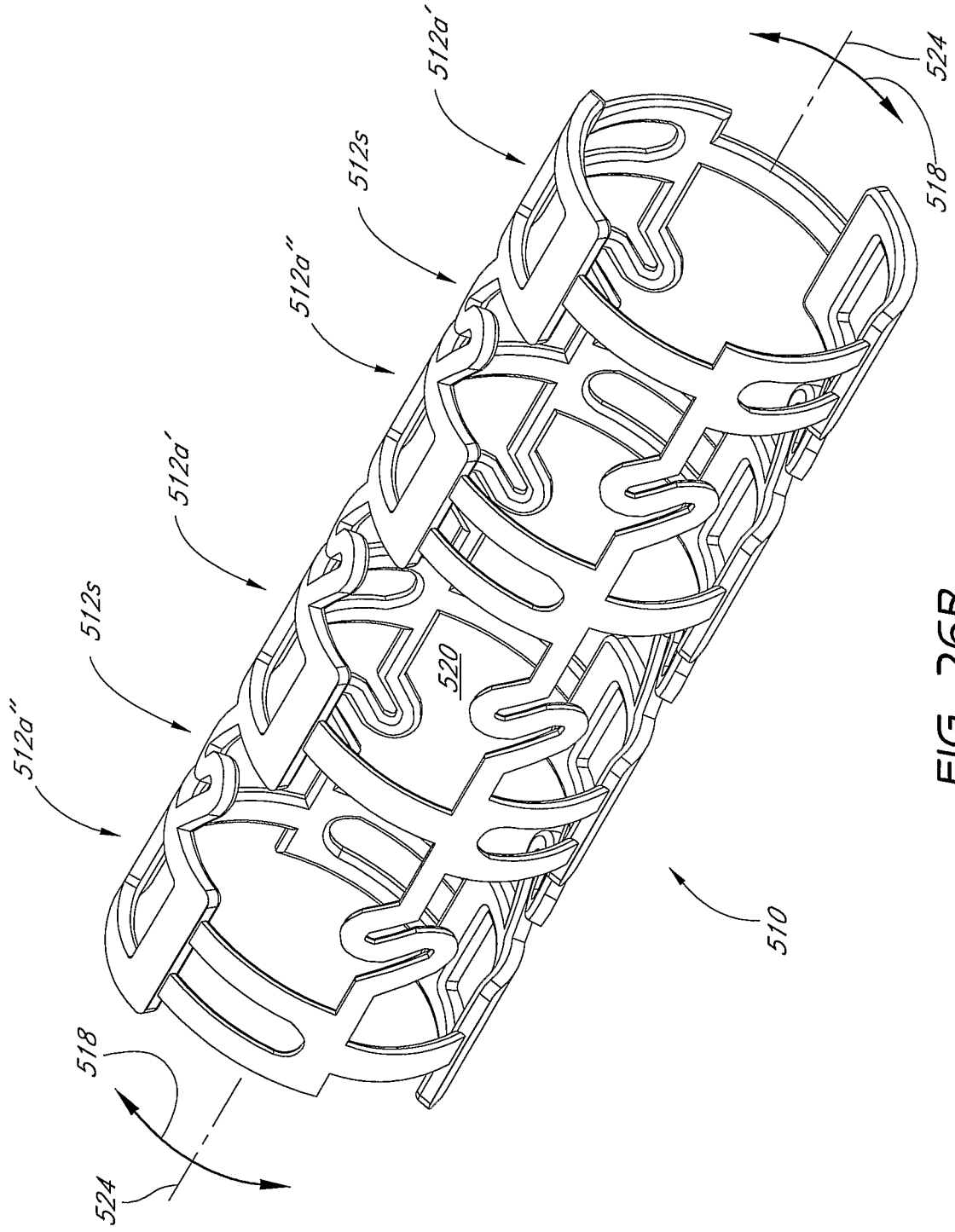

FIG. 26B

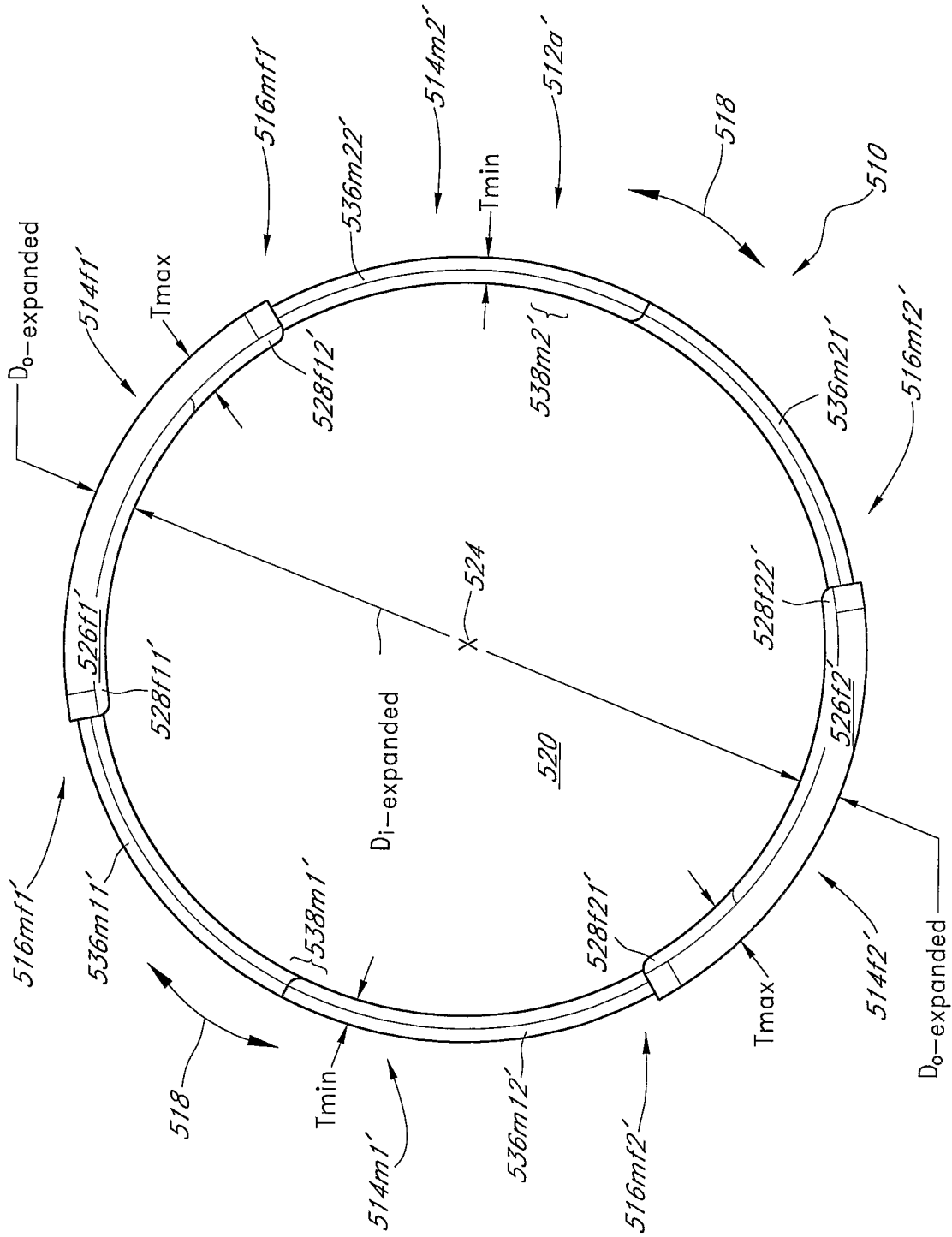
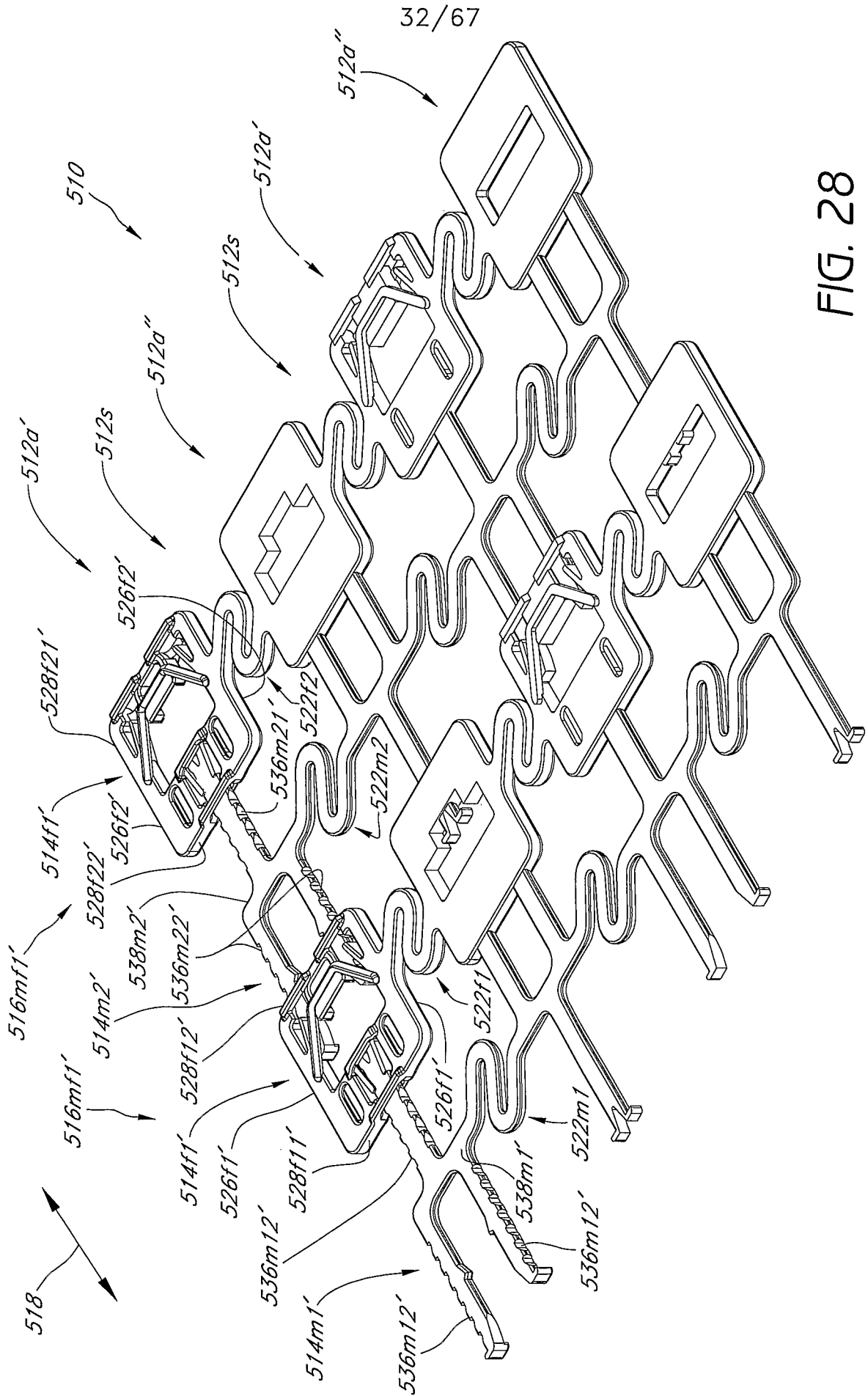

FIG. 27



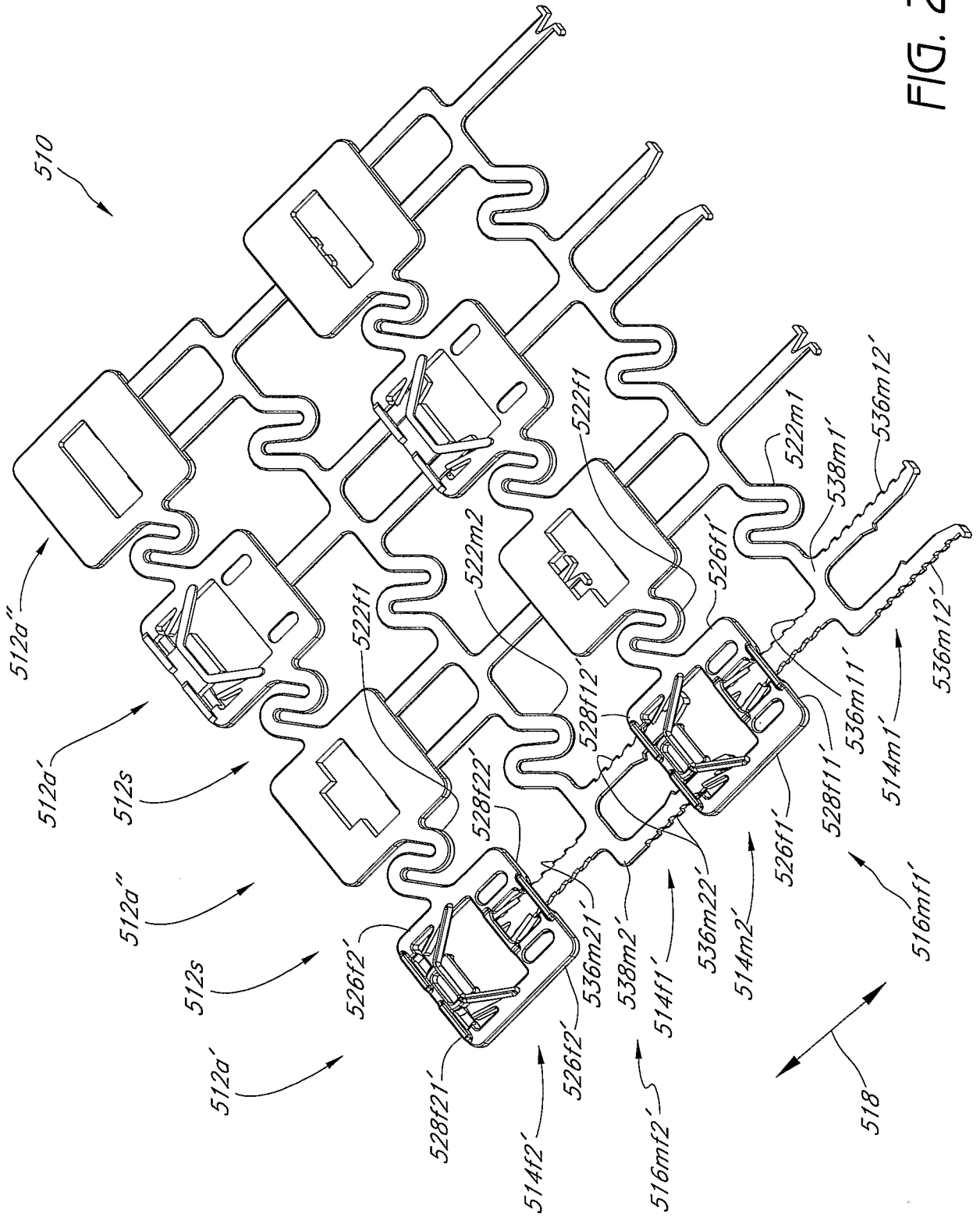

FIG. 29

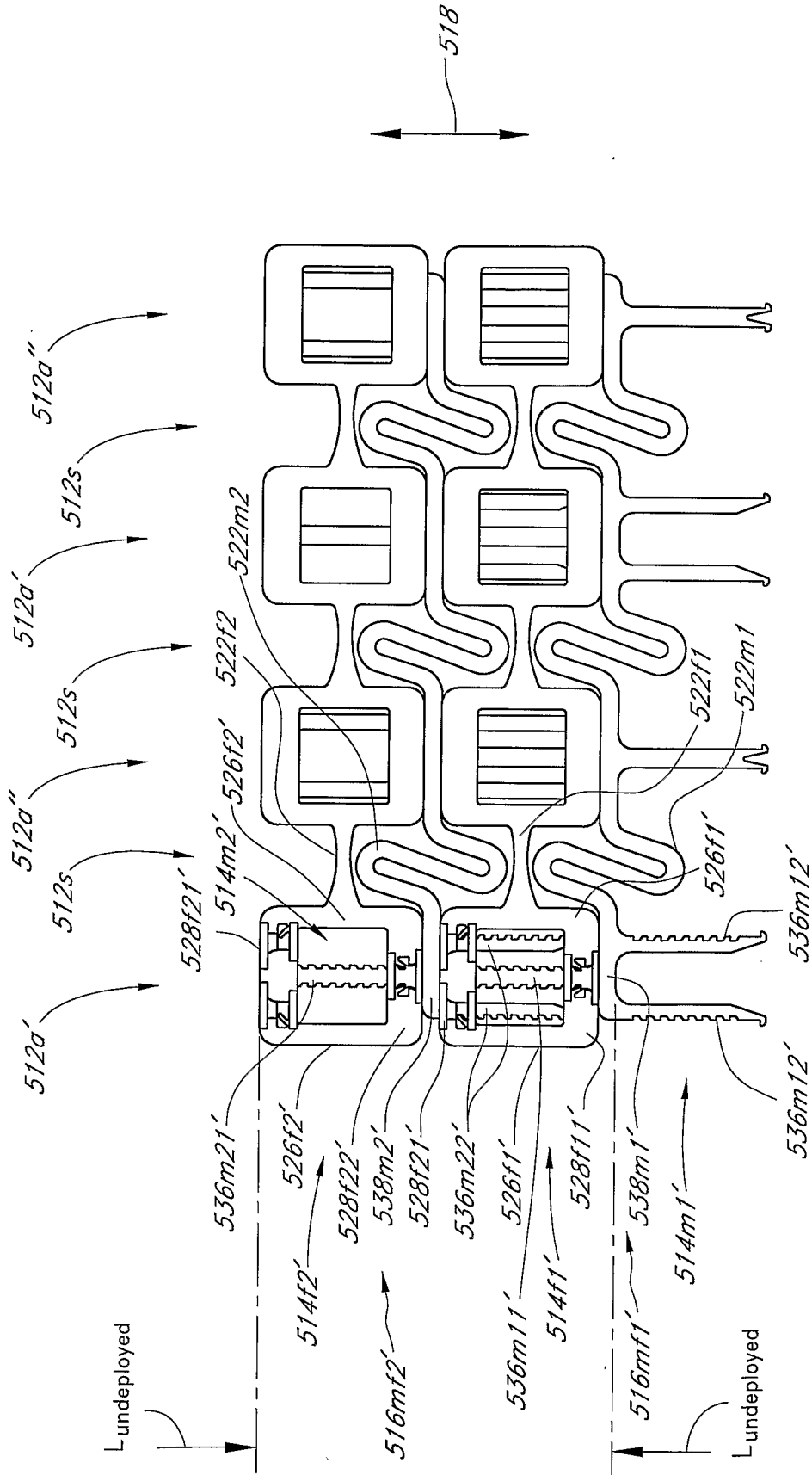

FIG. 30

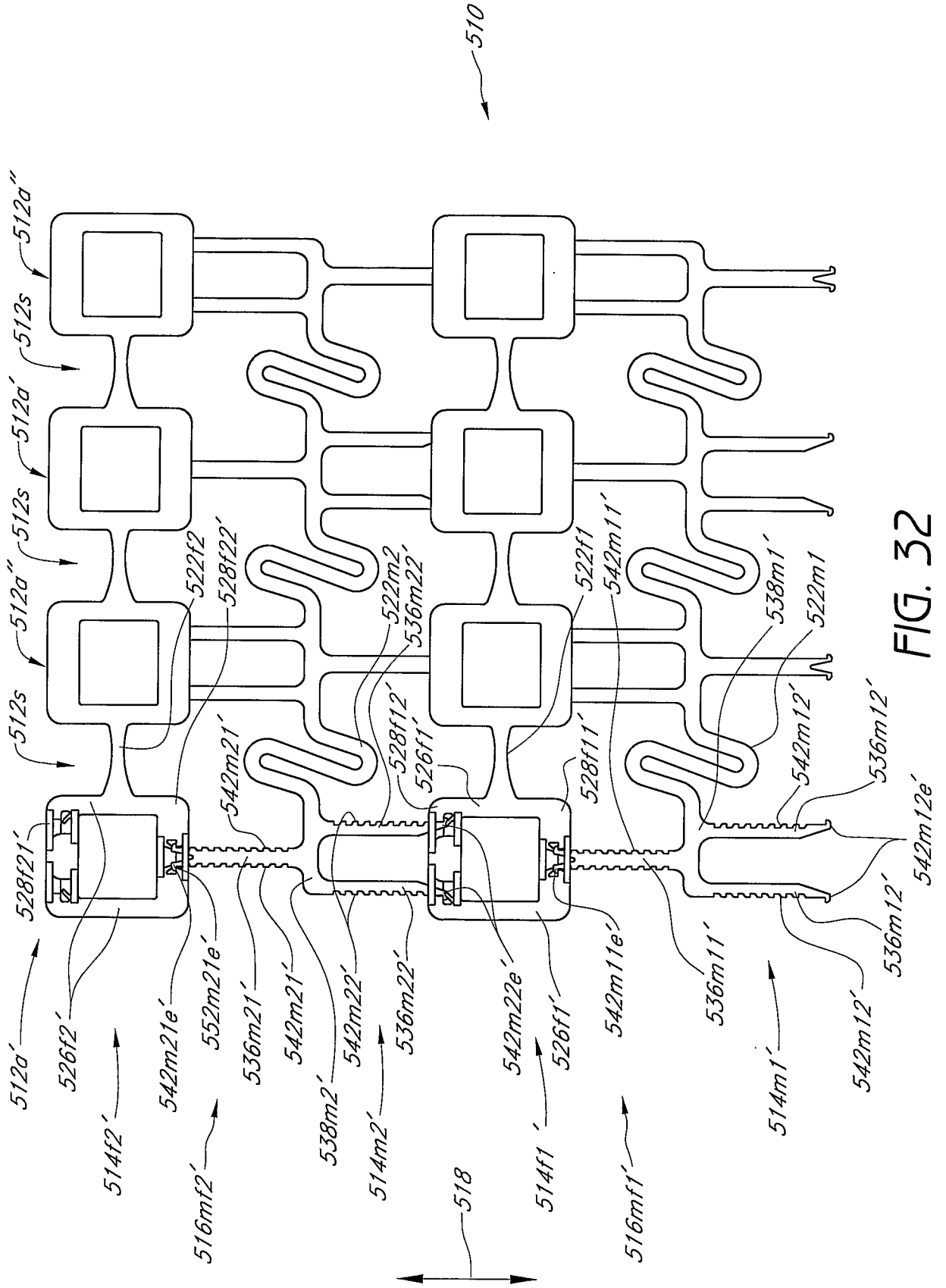
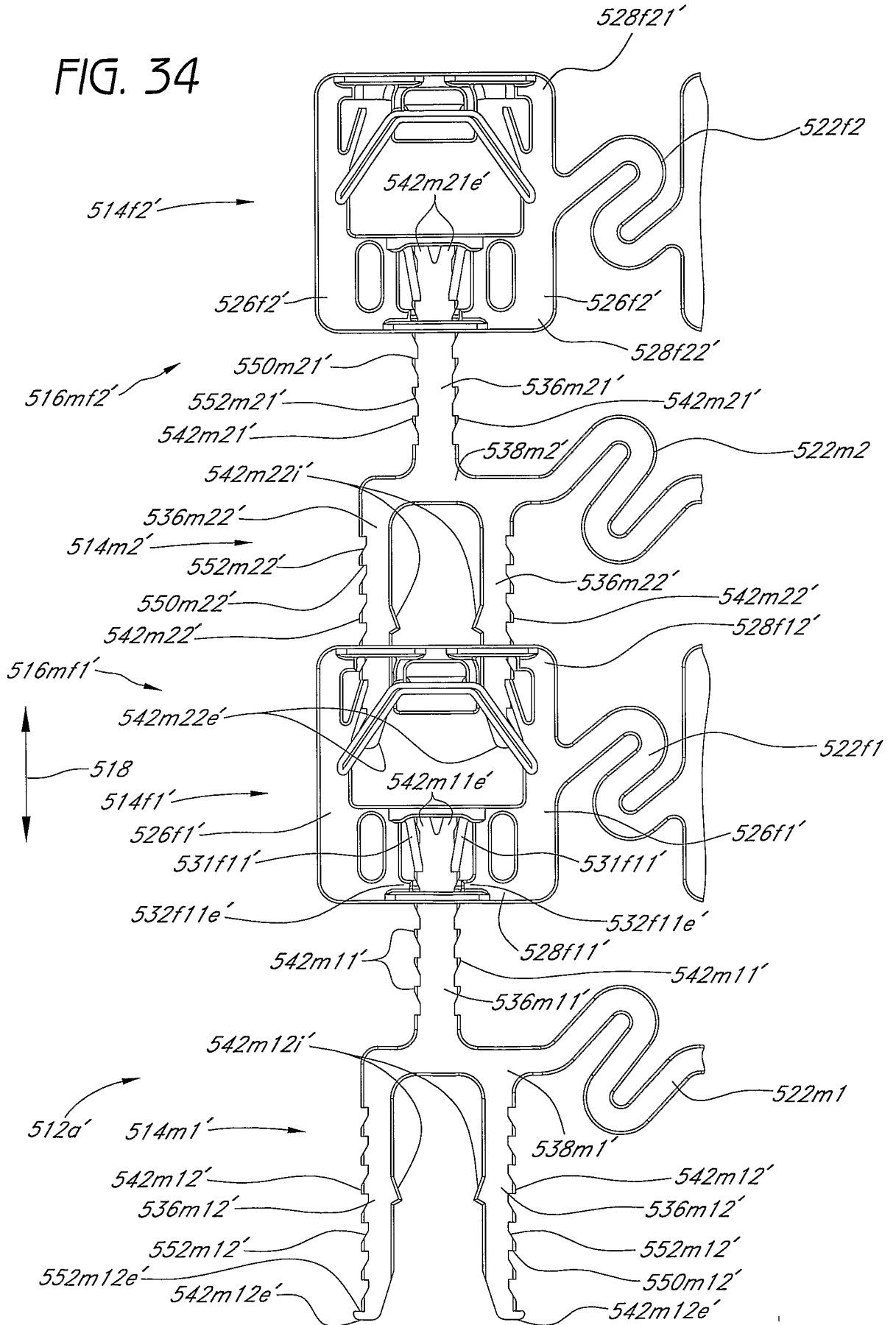

FIG. 32

FIG. 34



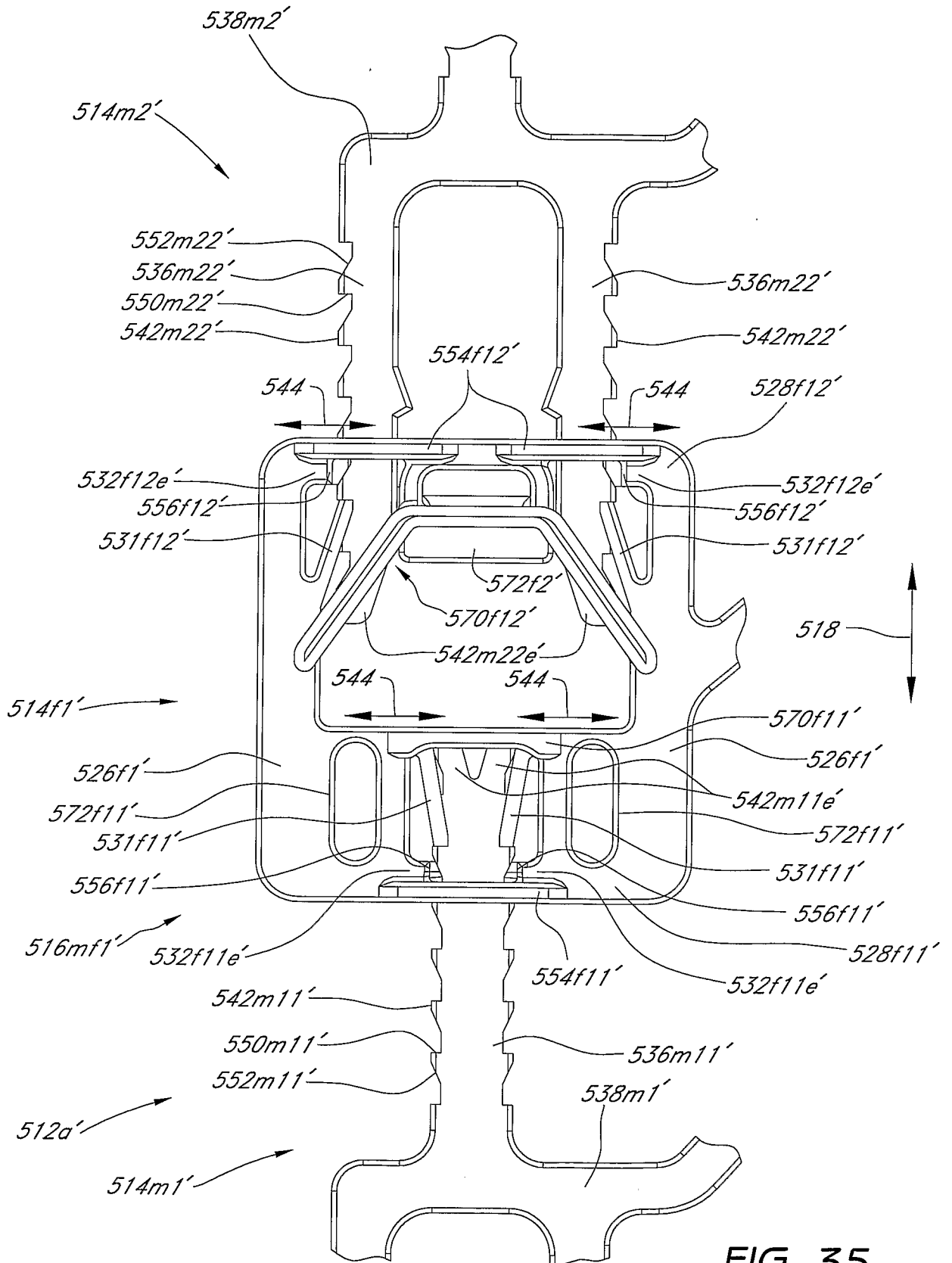

FIG. 35

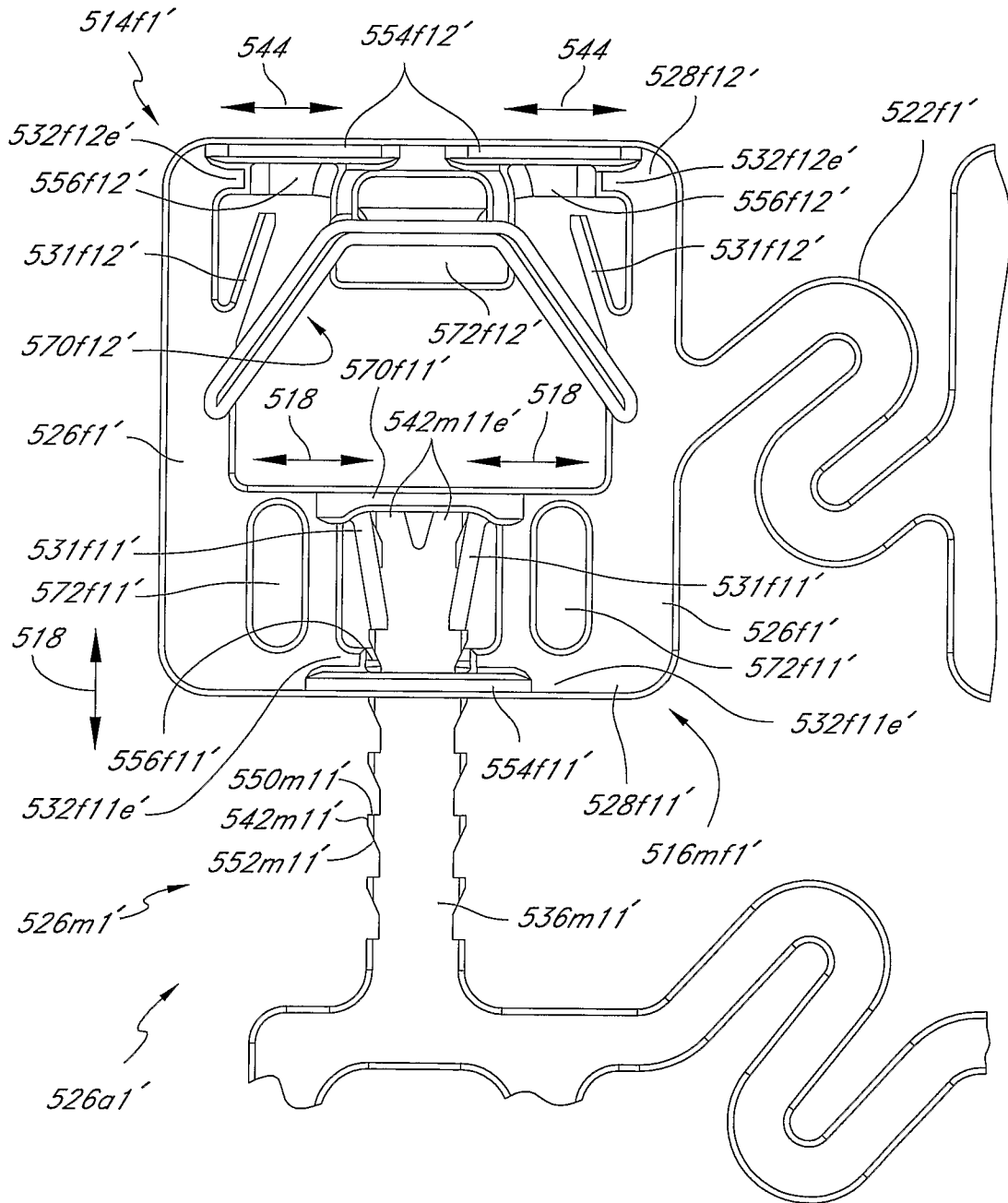

FIG. 36

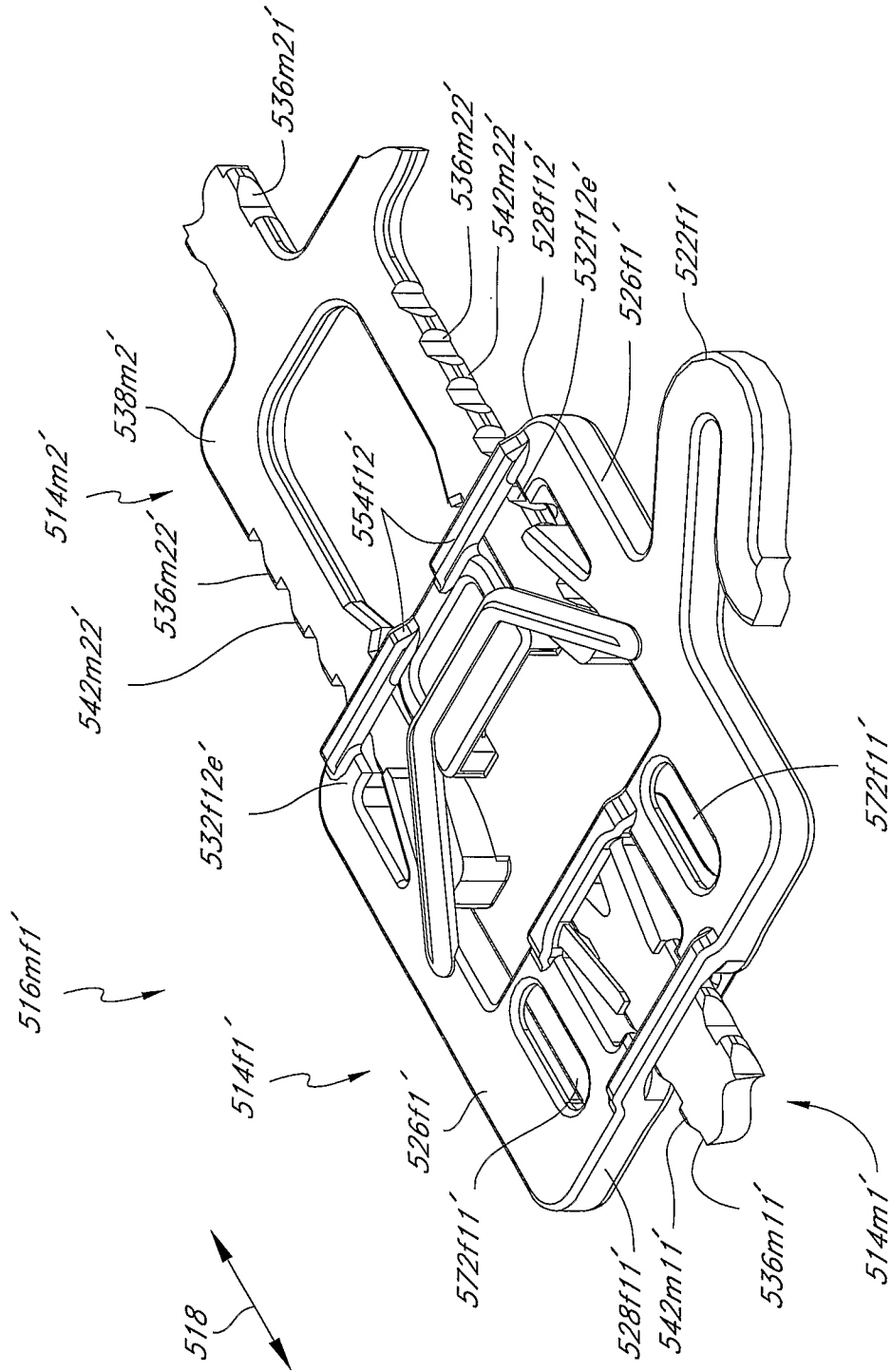

FIG. 37

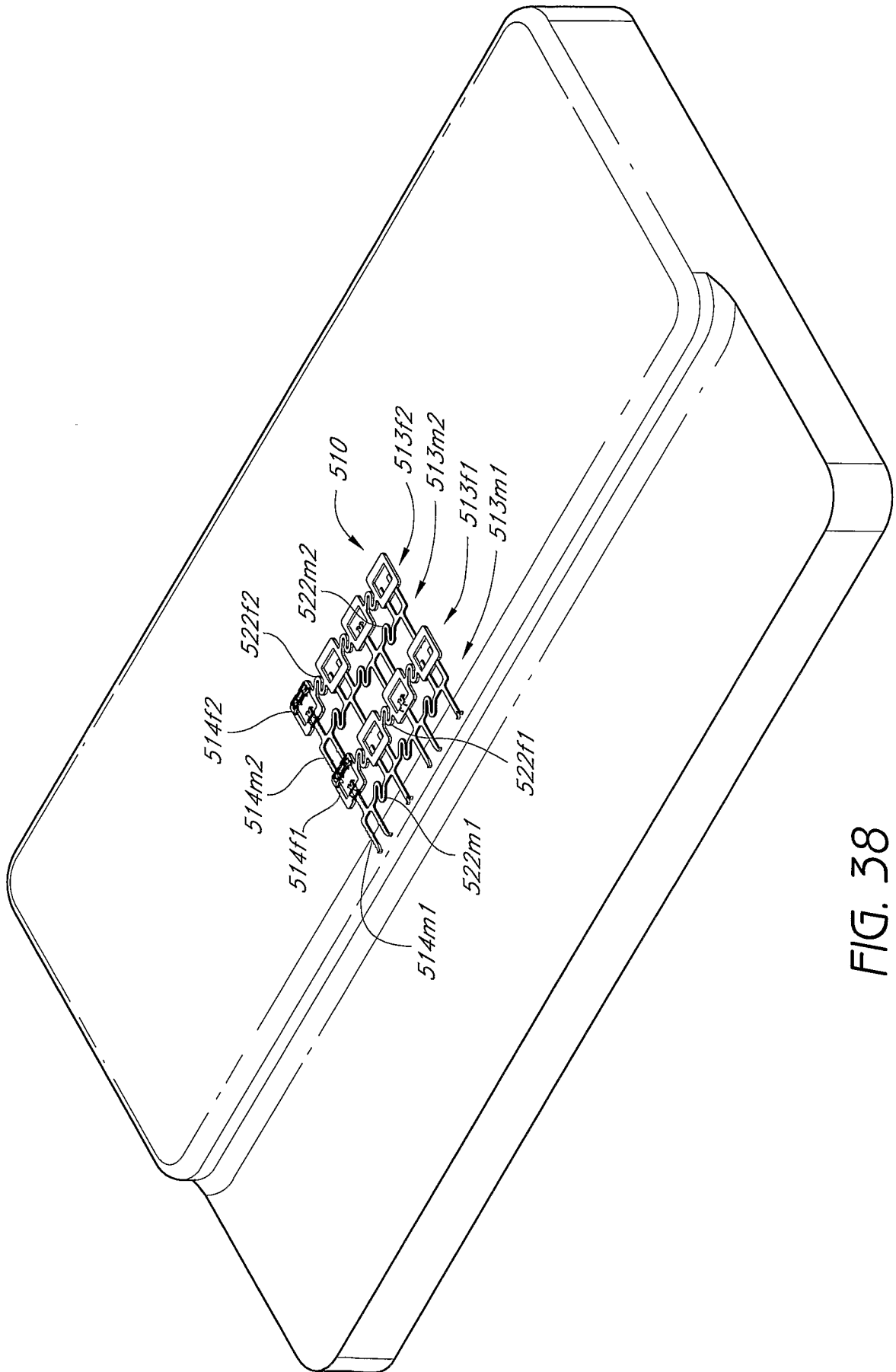

FIG. 38

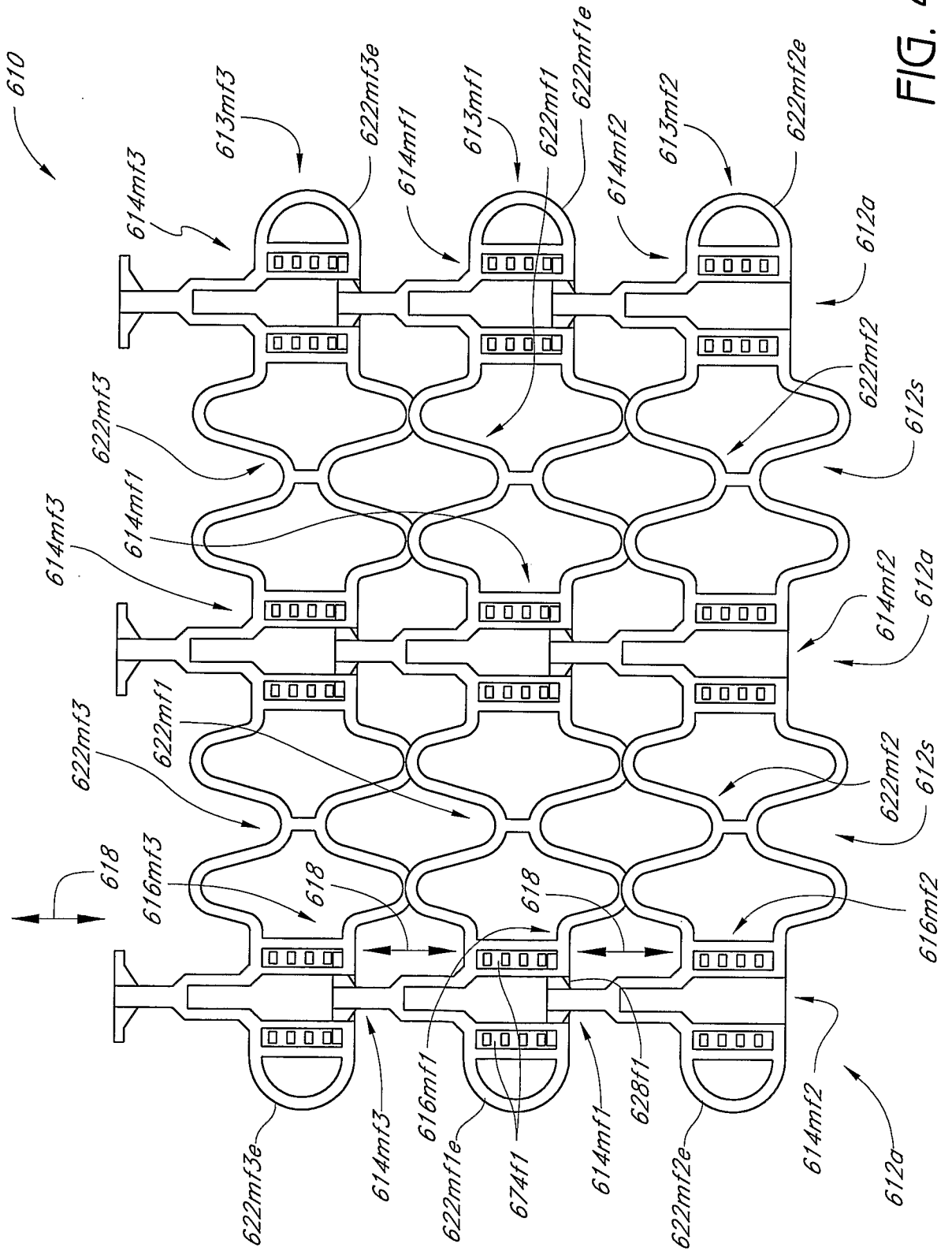

FIG. 40

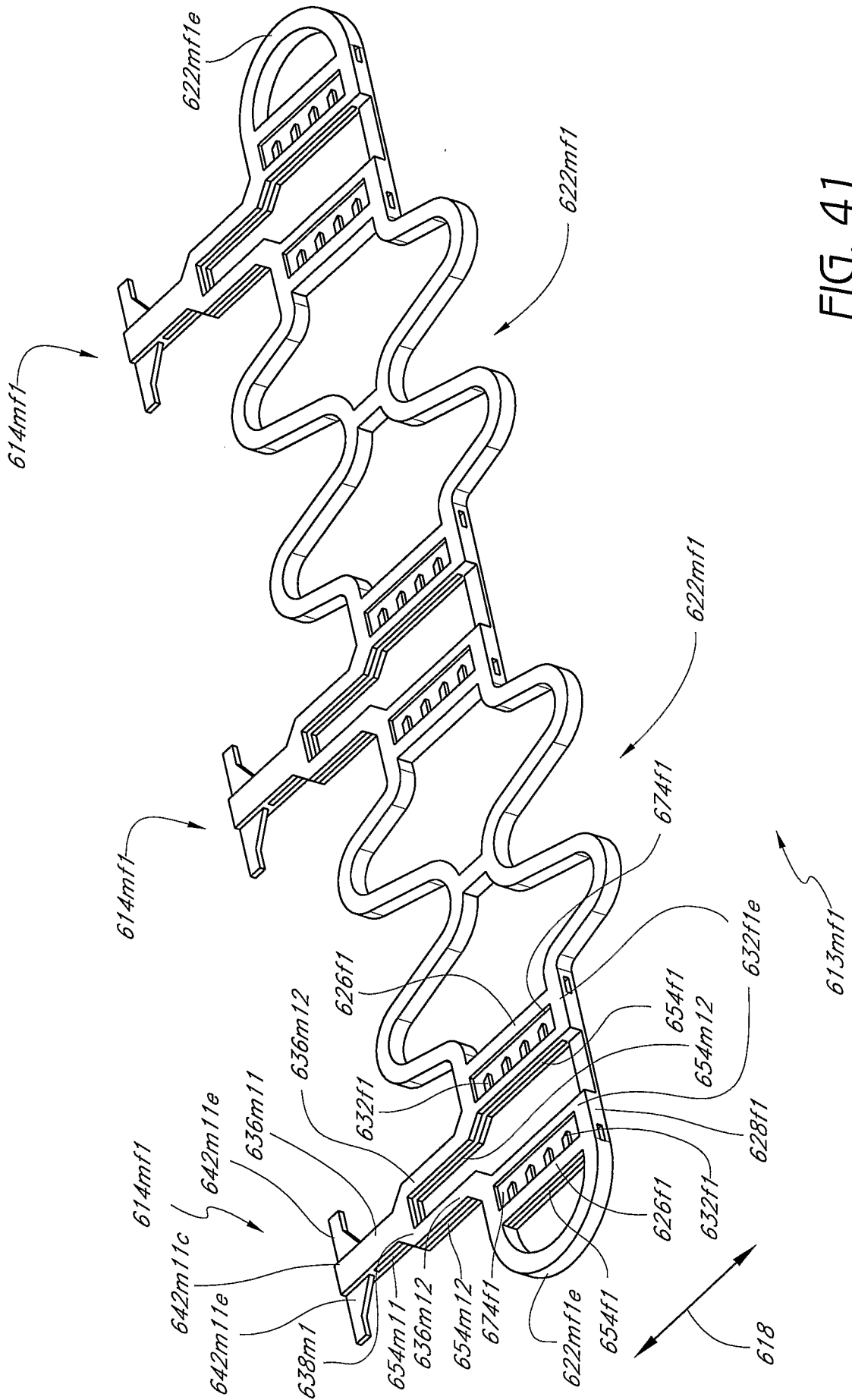

FIG. 41

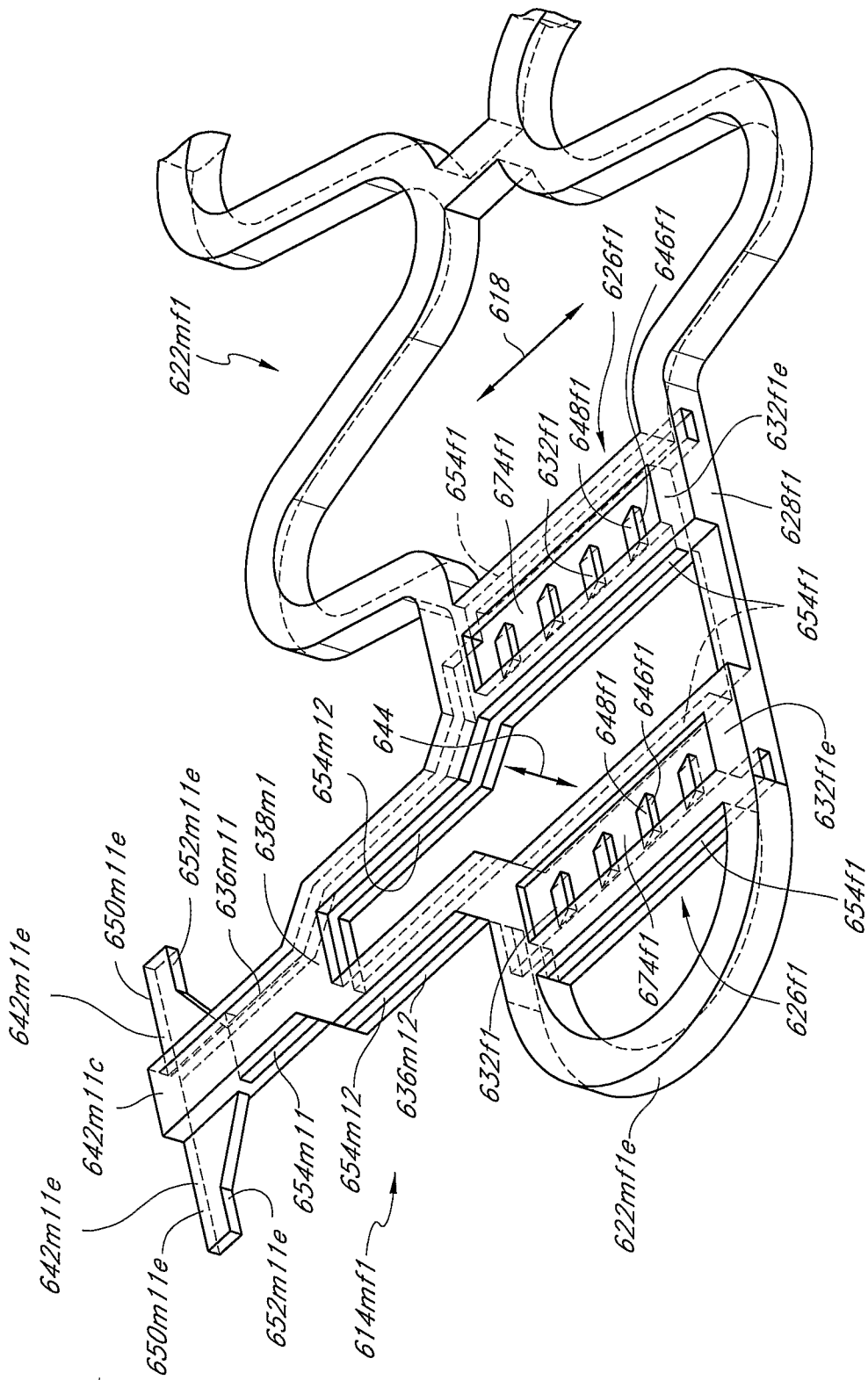

FIG. 42

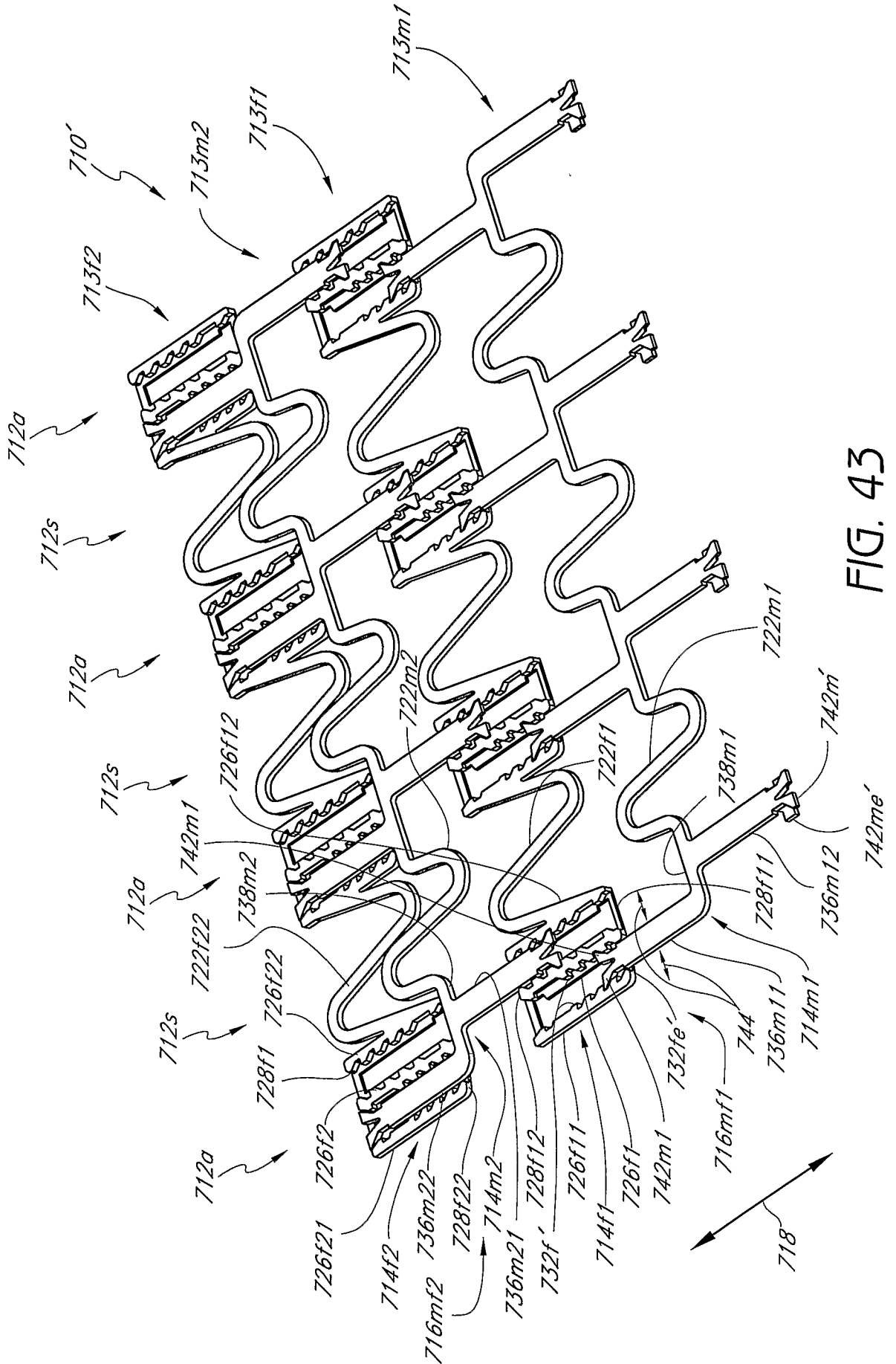

FIG. 43

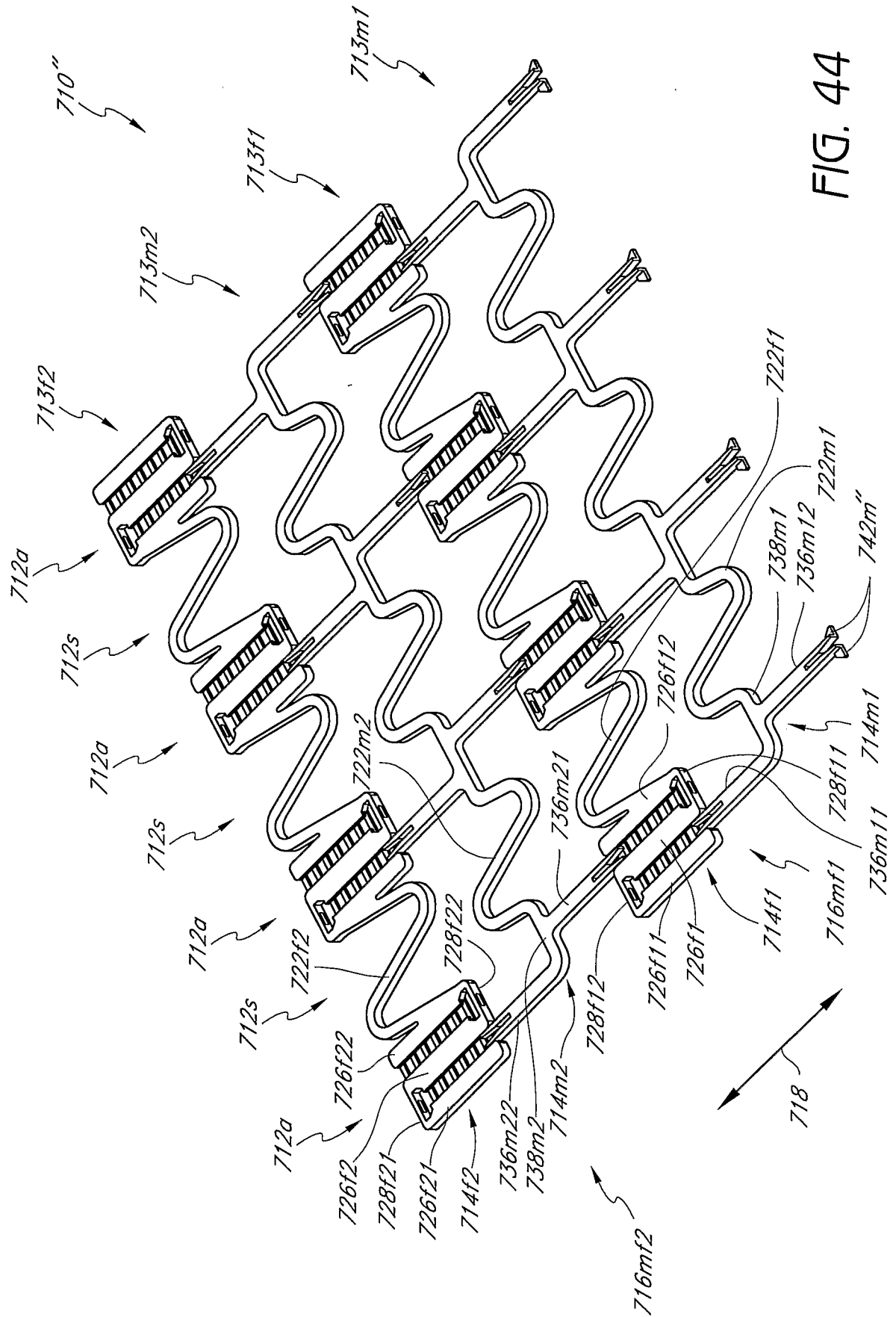

FIG. 44

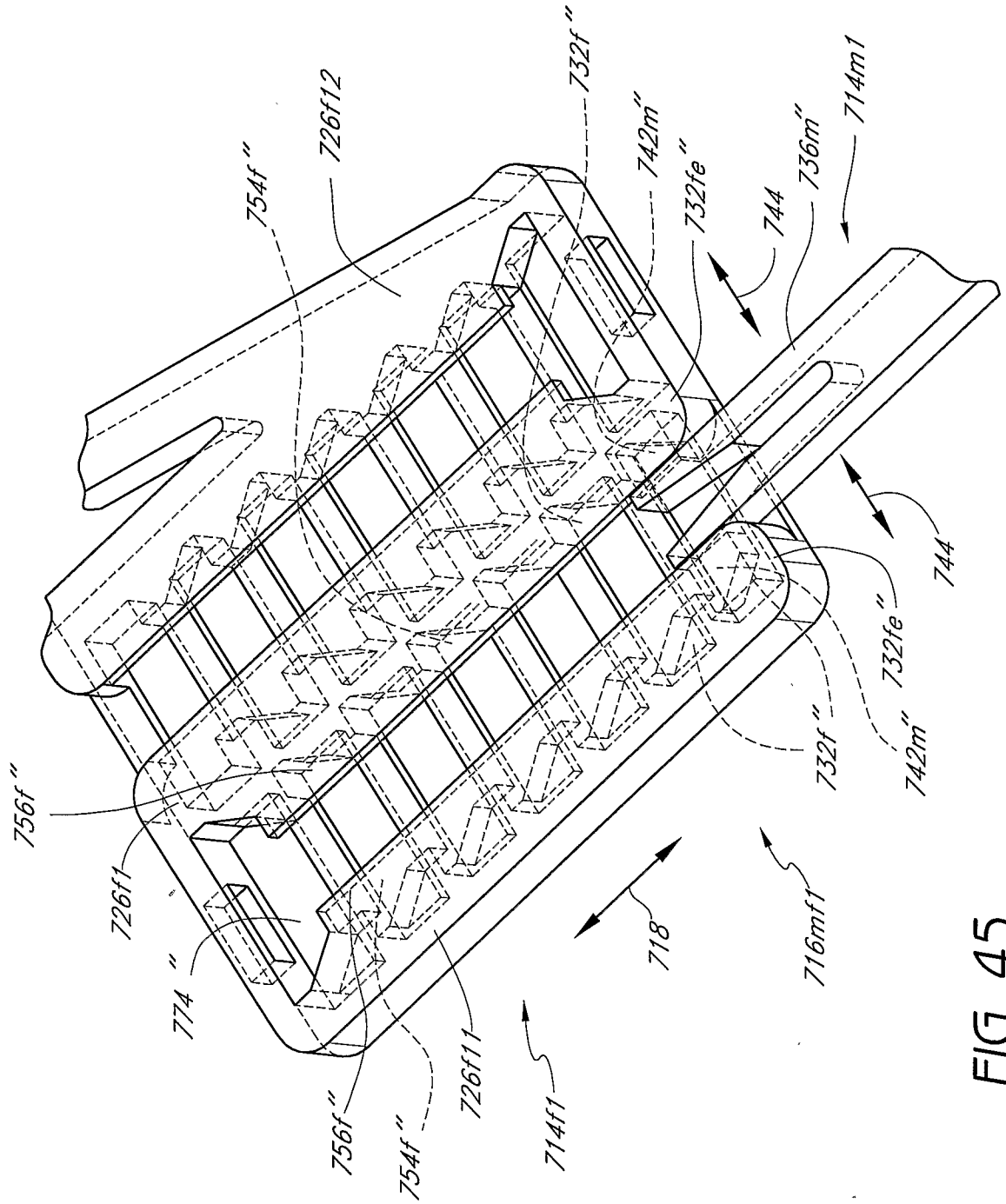

FIG. 45

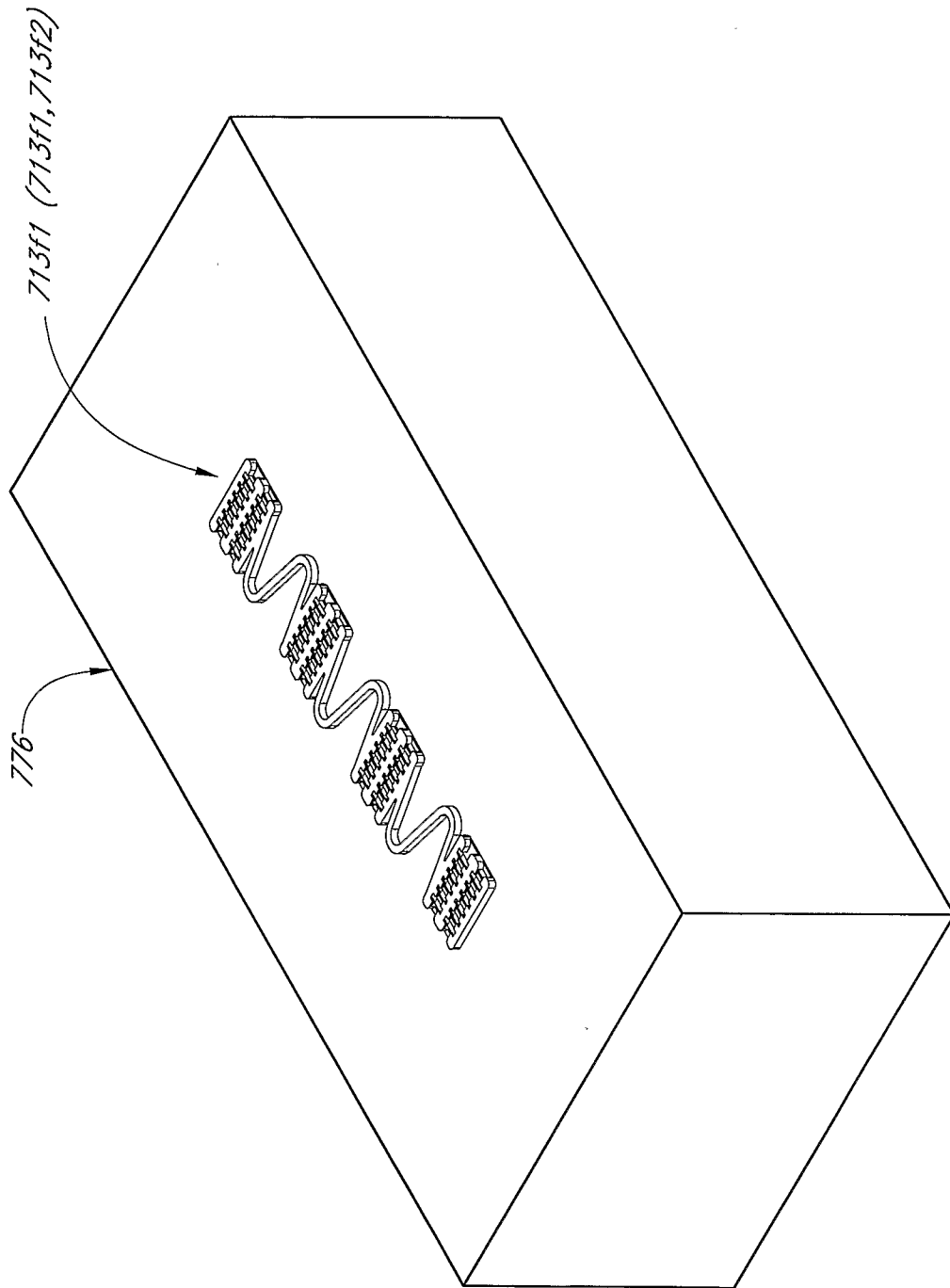

FIG. 46

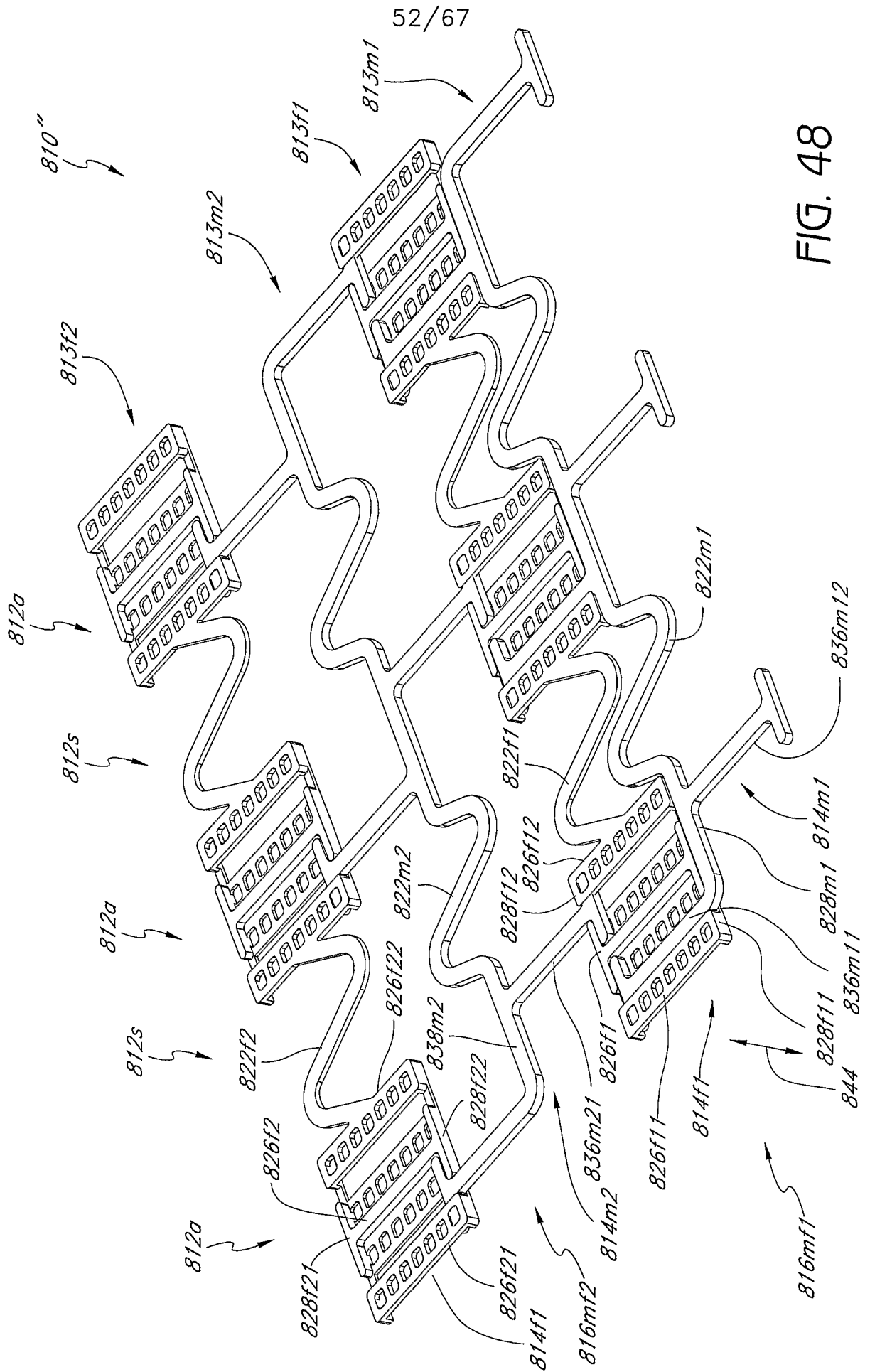

FIG. 48

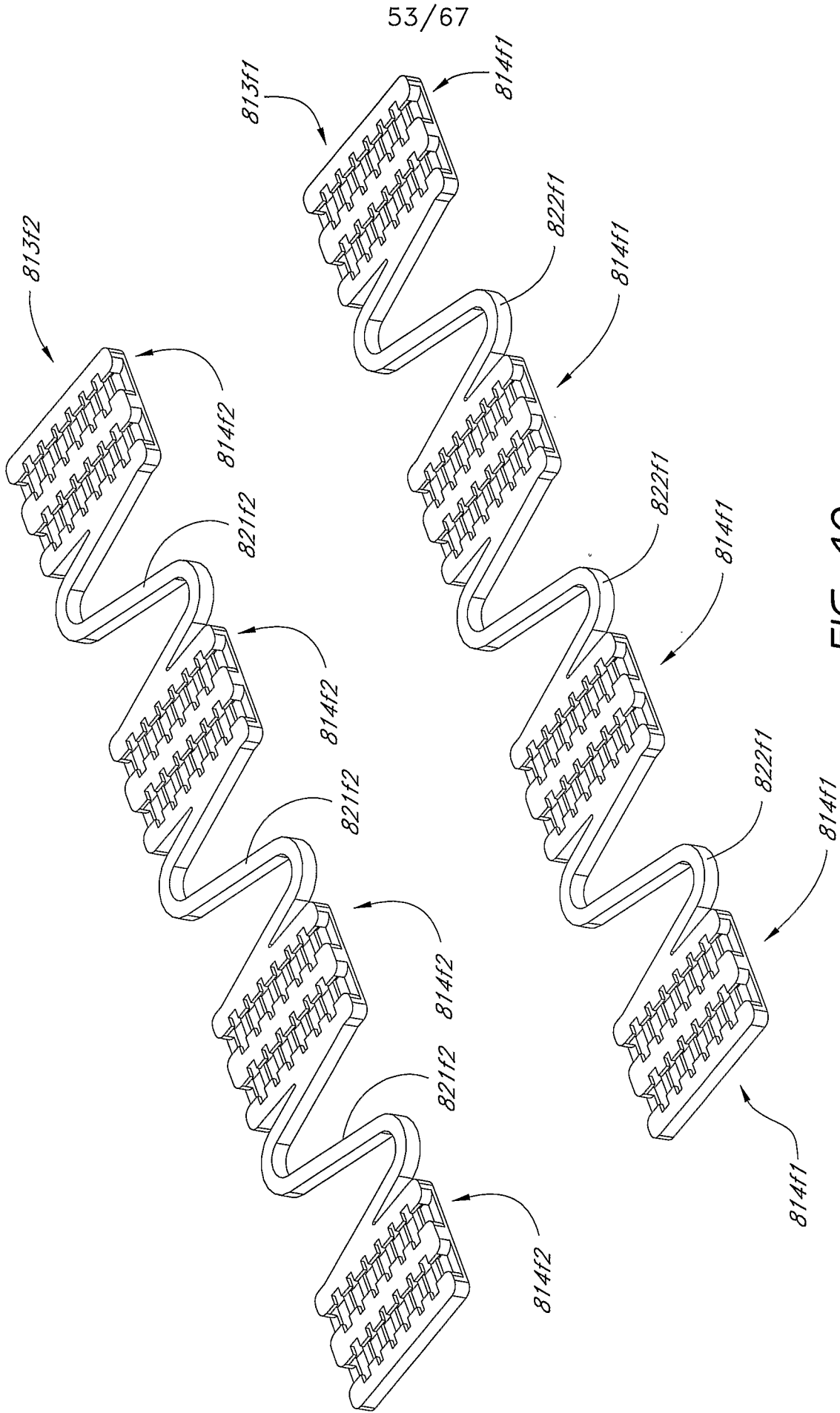

FIG. 49

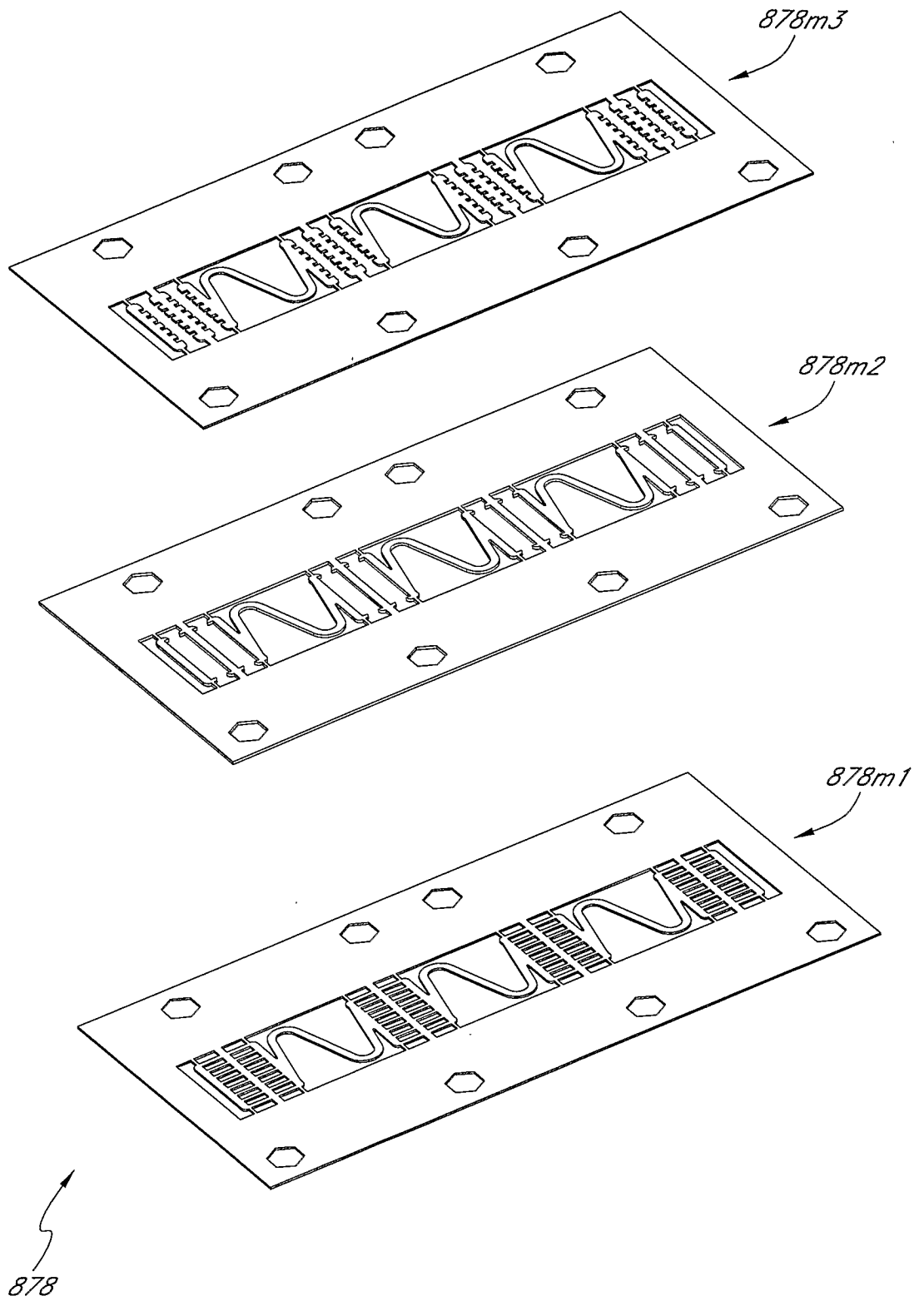
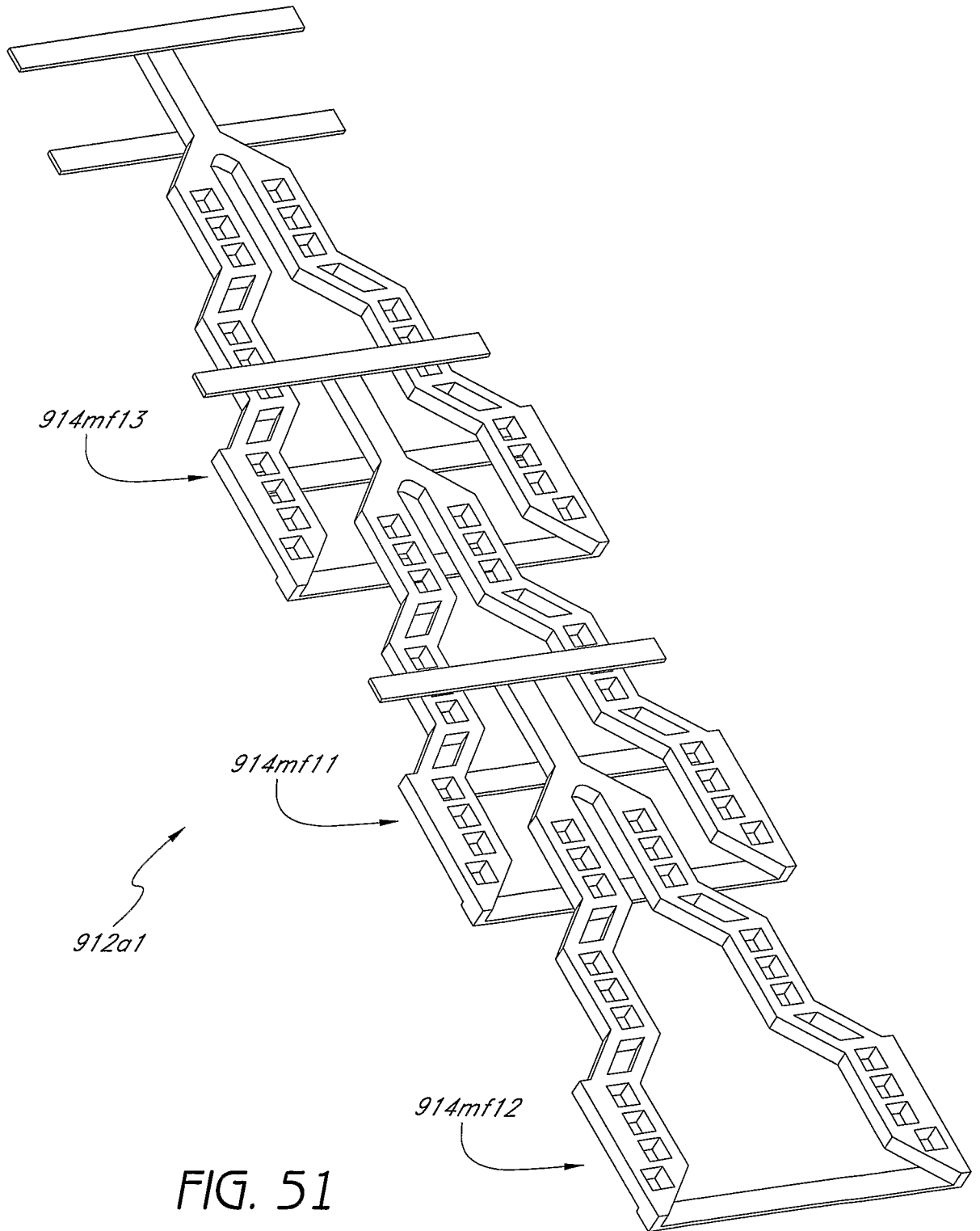

FIG. 50



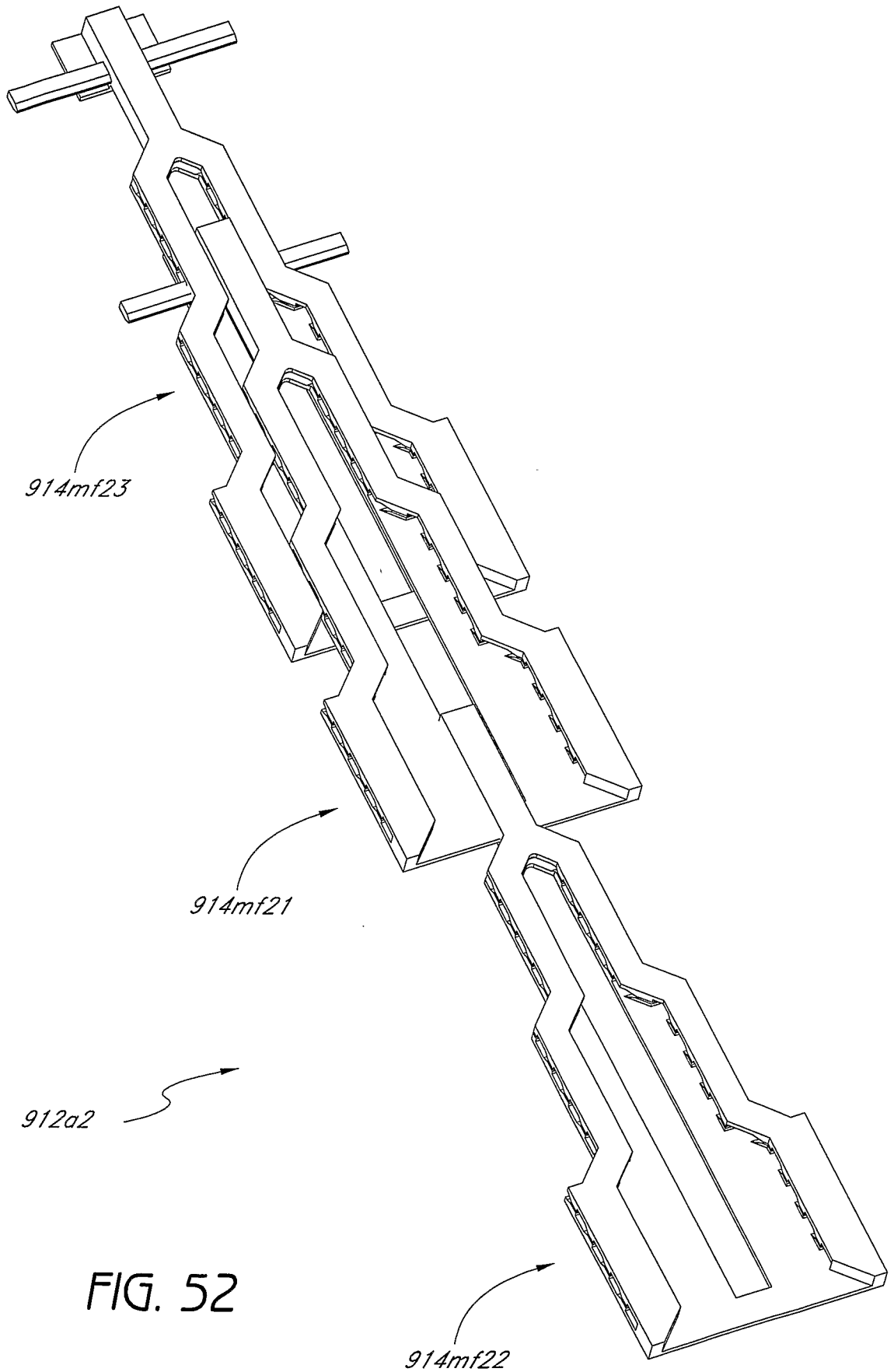

FIG. 52

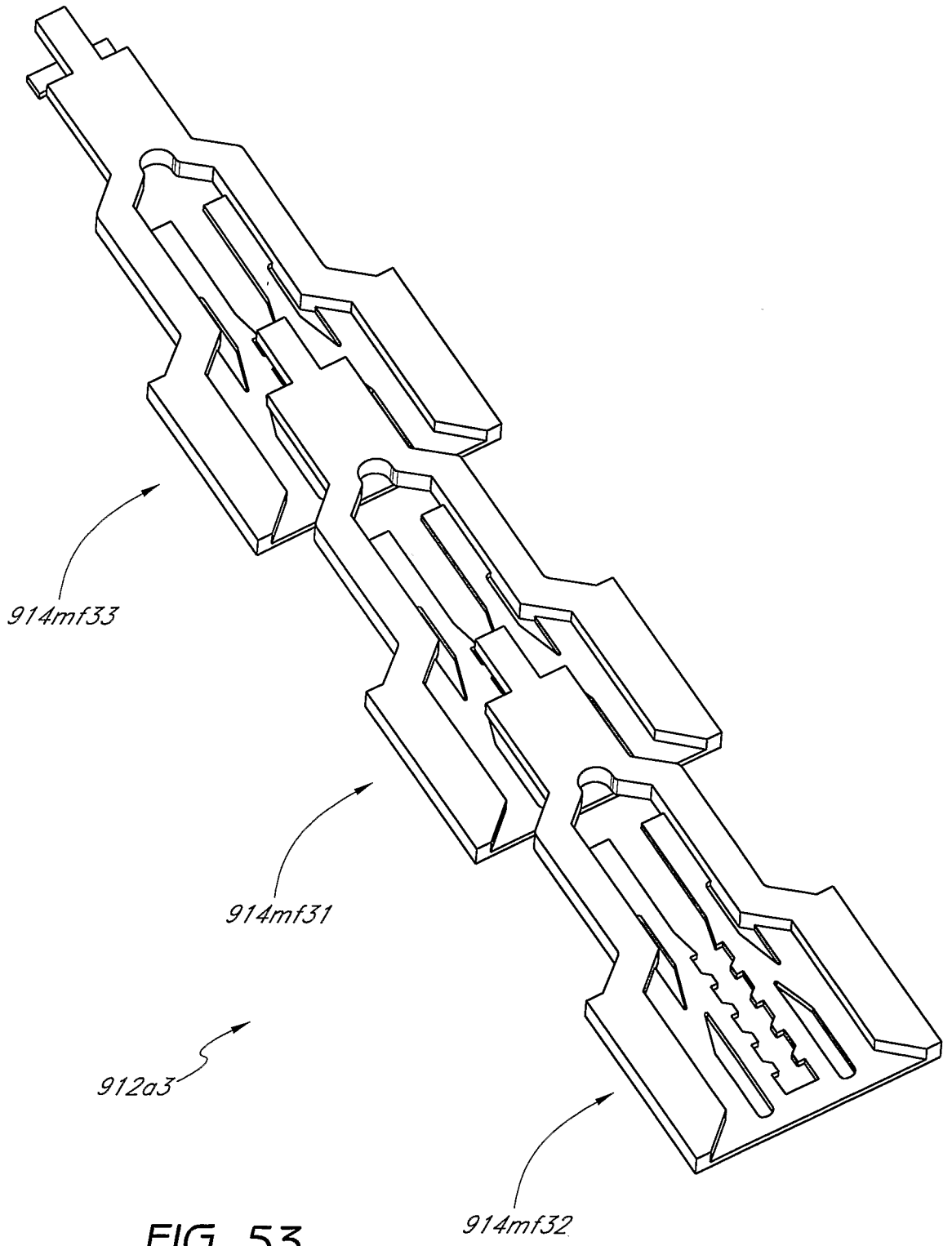

FIG. 53

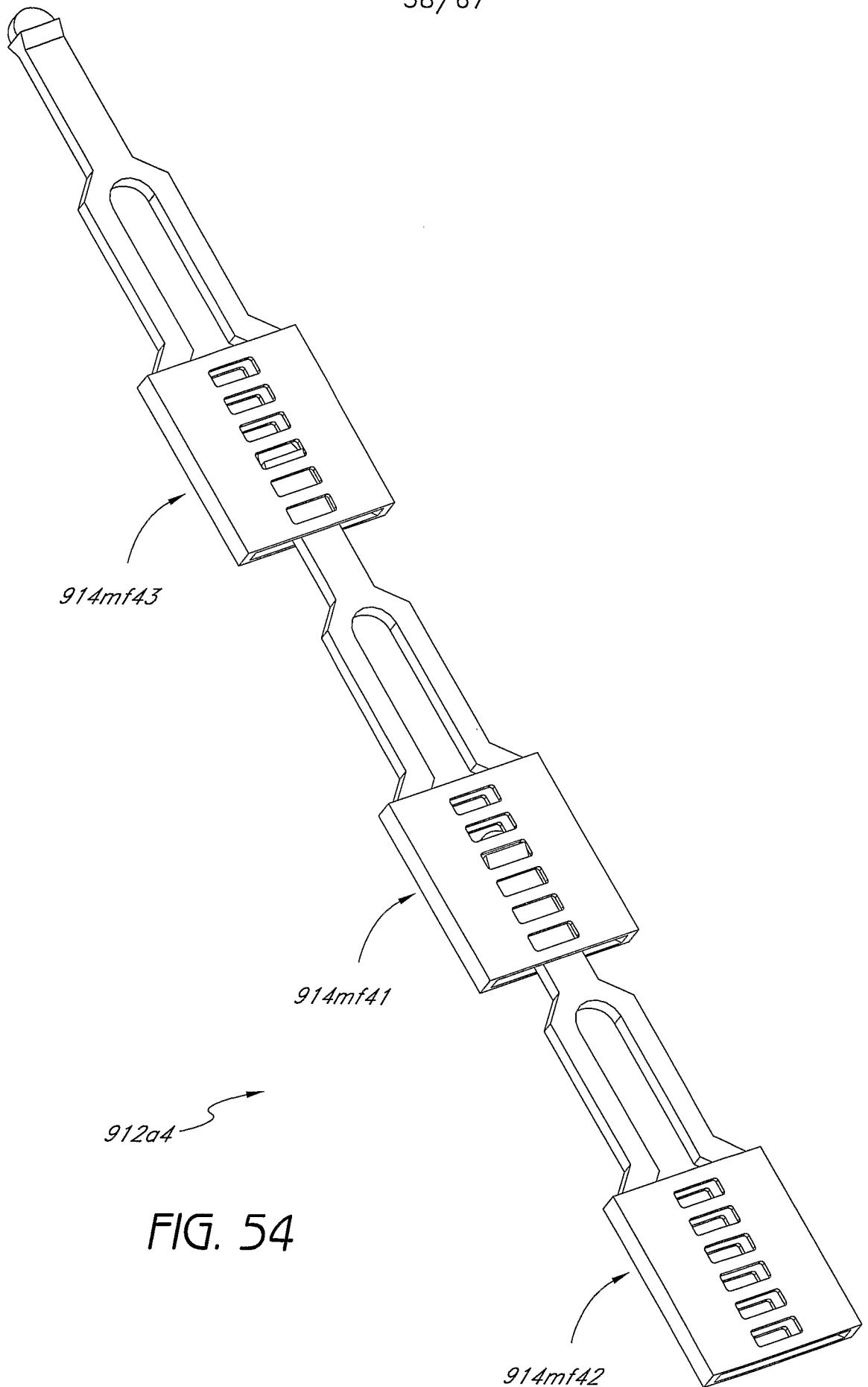

FIG. 54

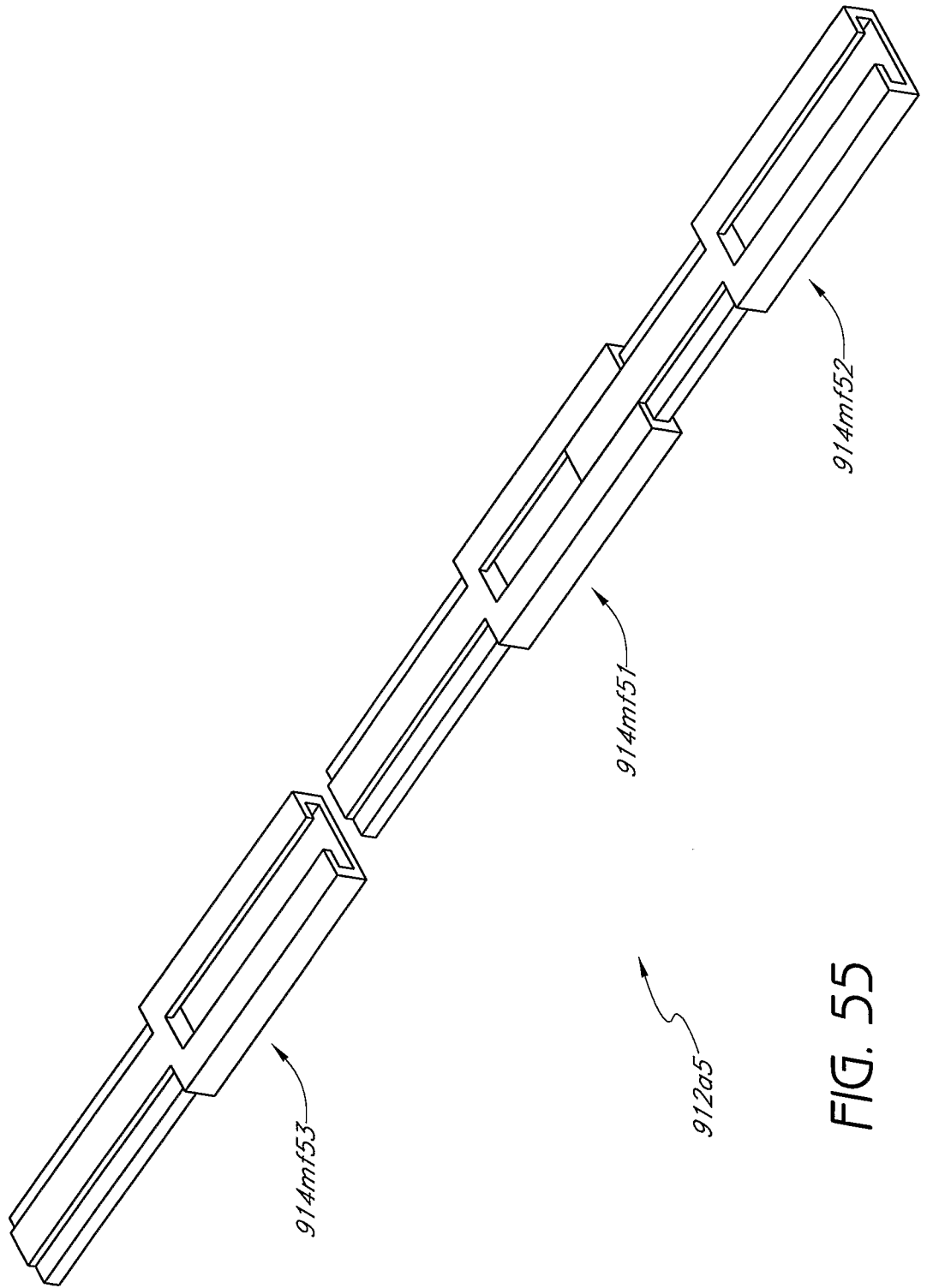

FIG. 55

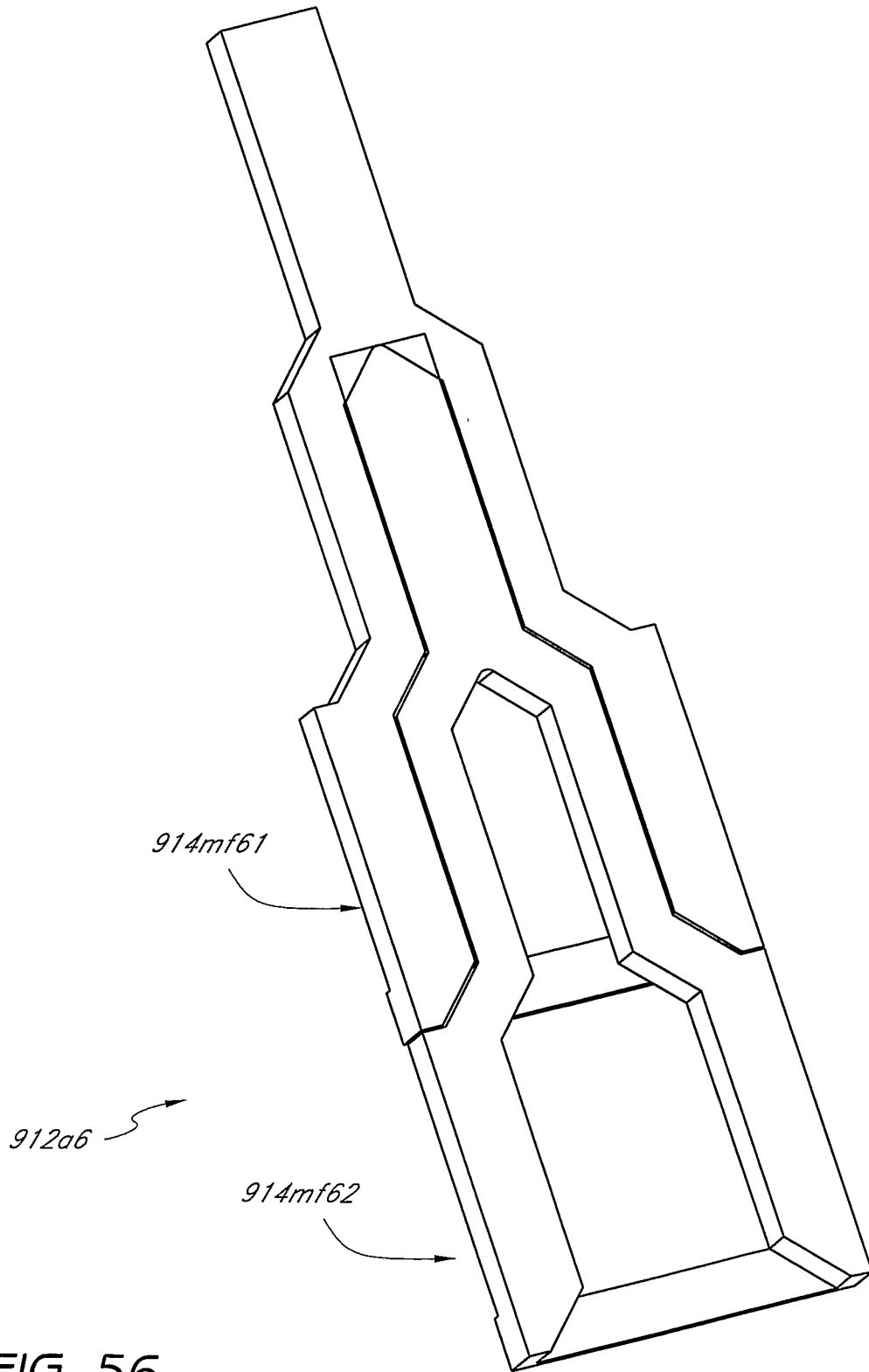

FIG. 56

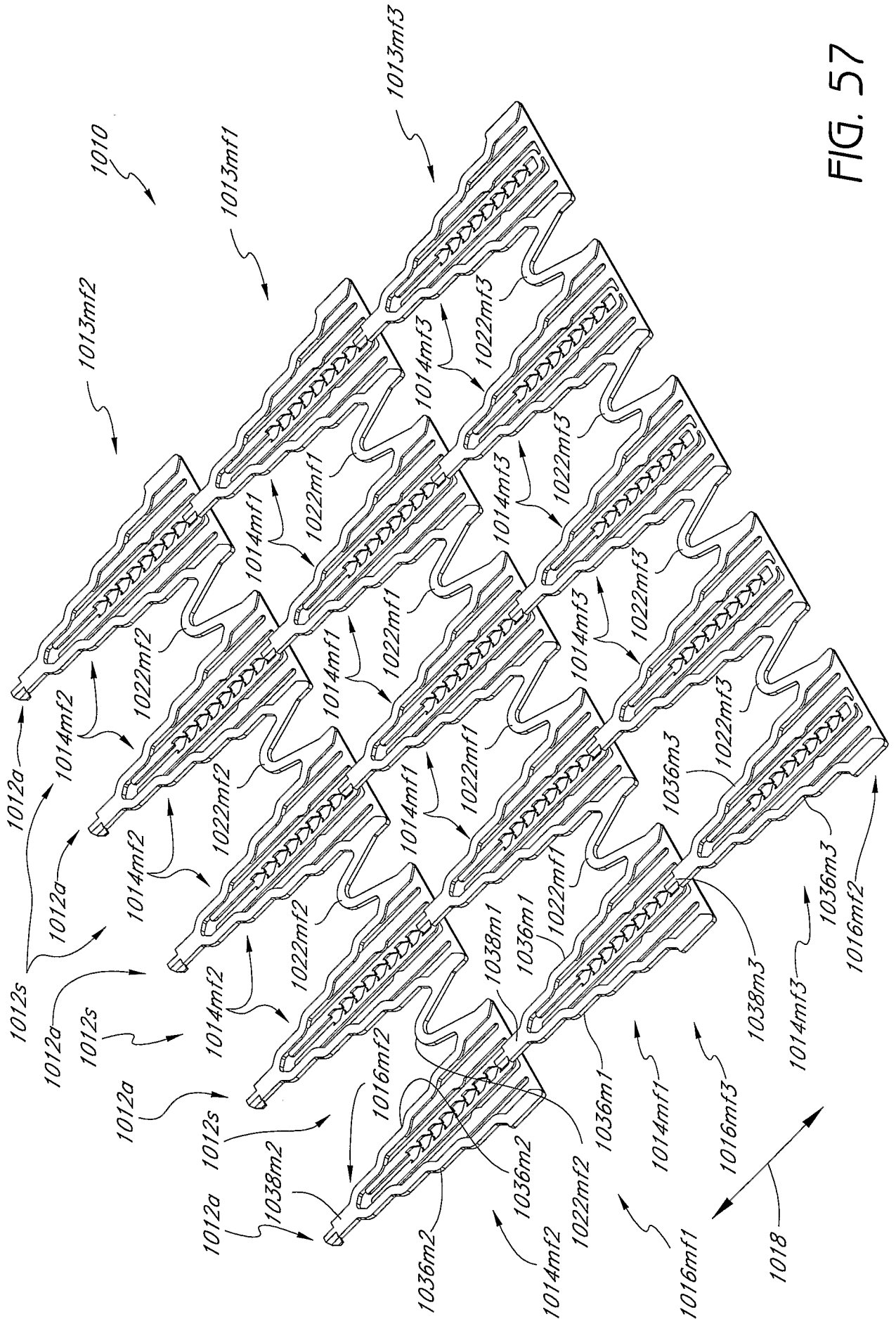

FIG. 57

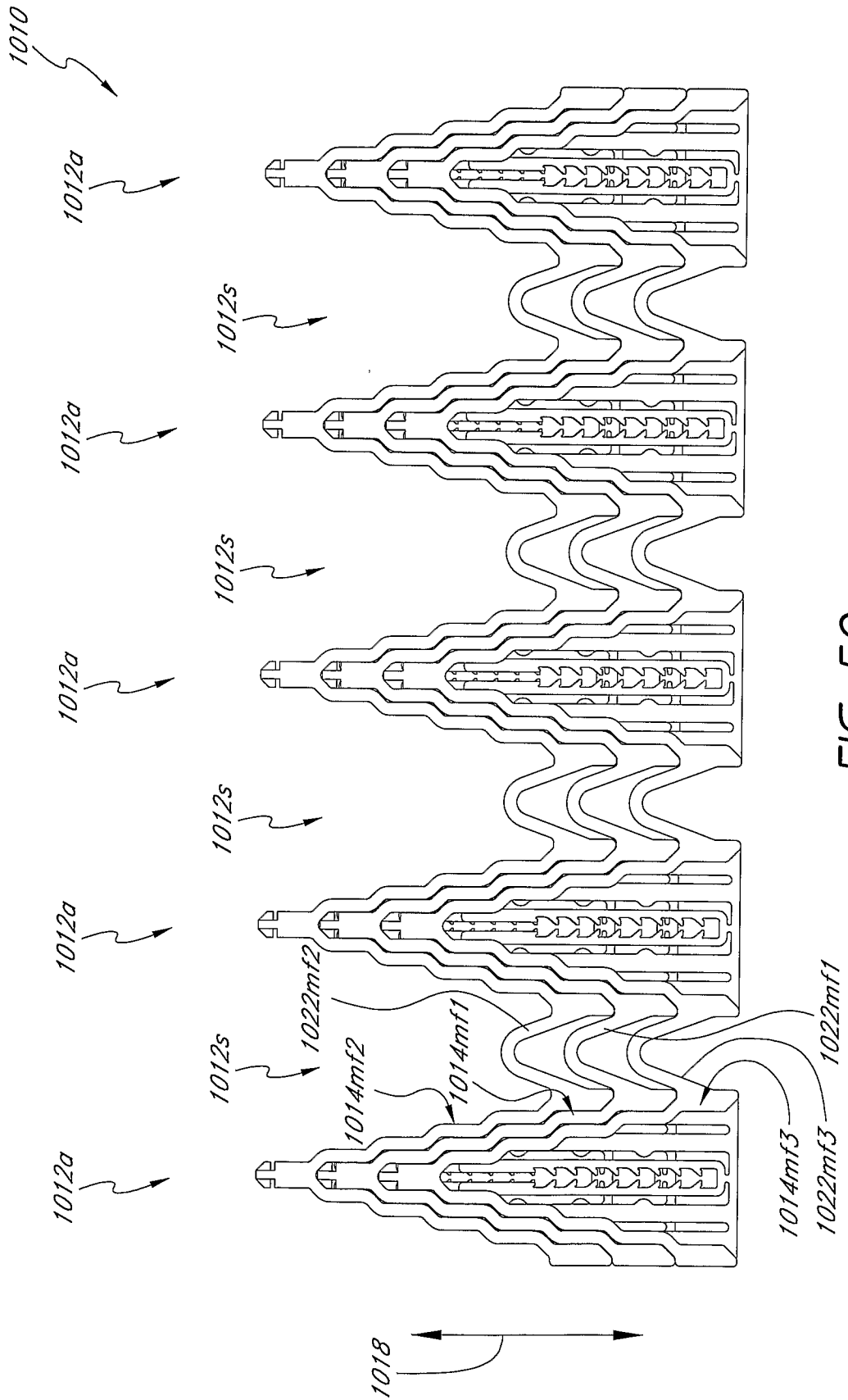

FIG. 59

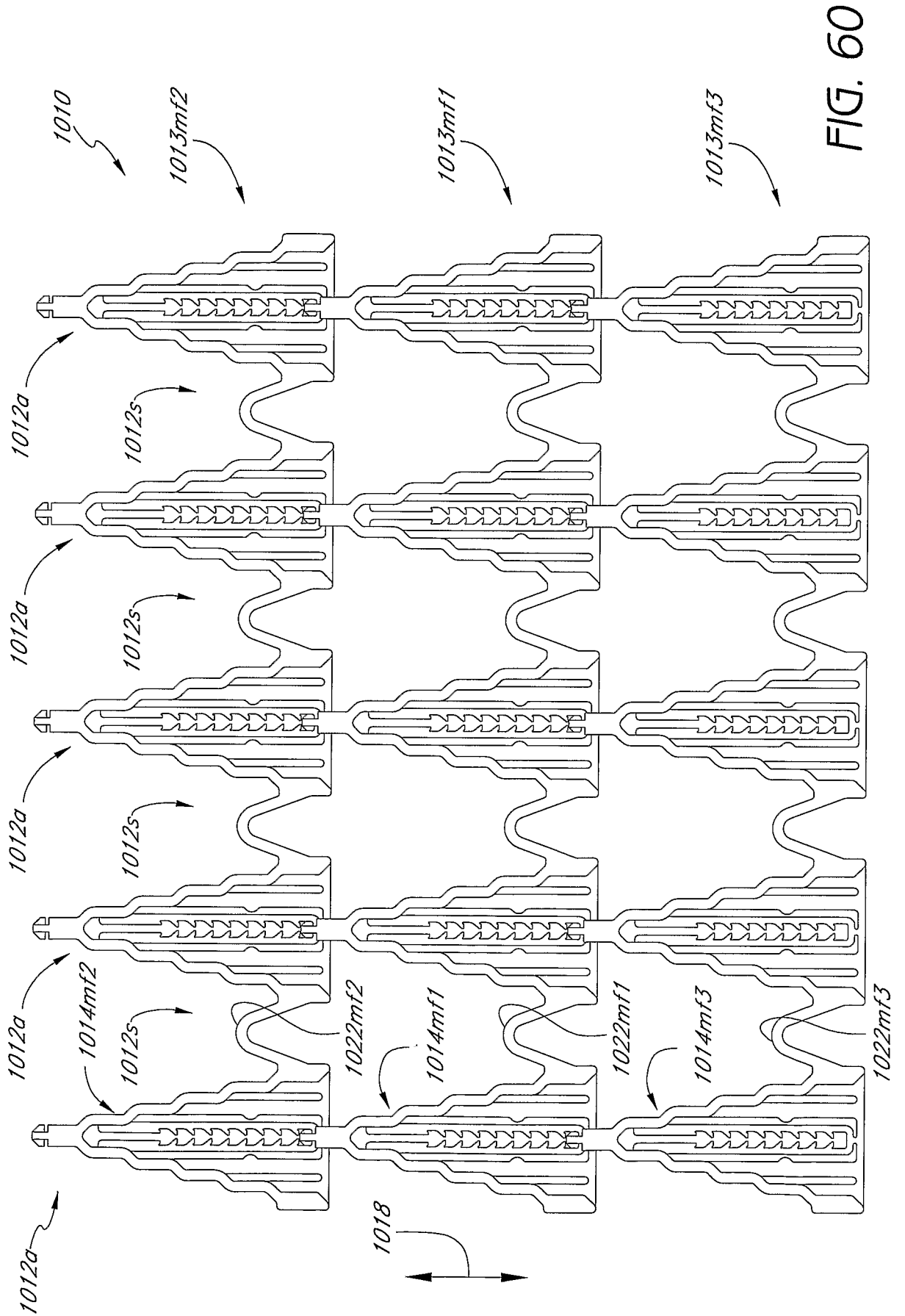

FIG. 60

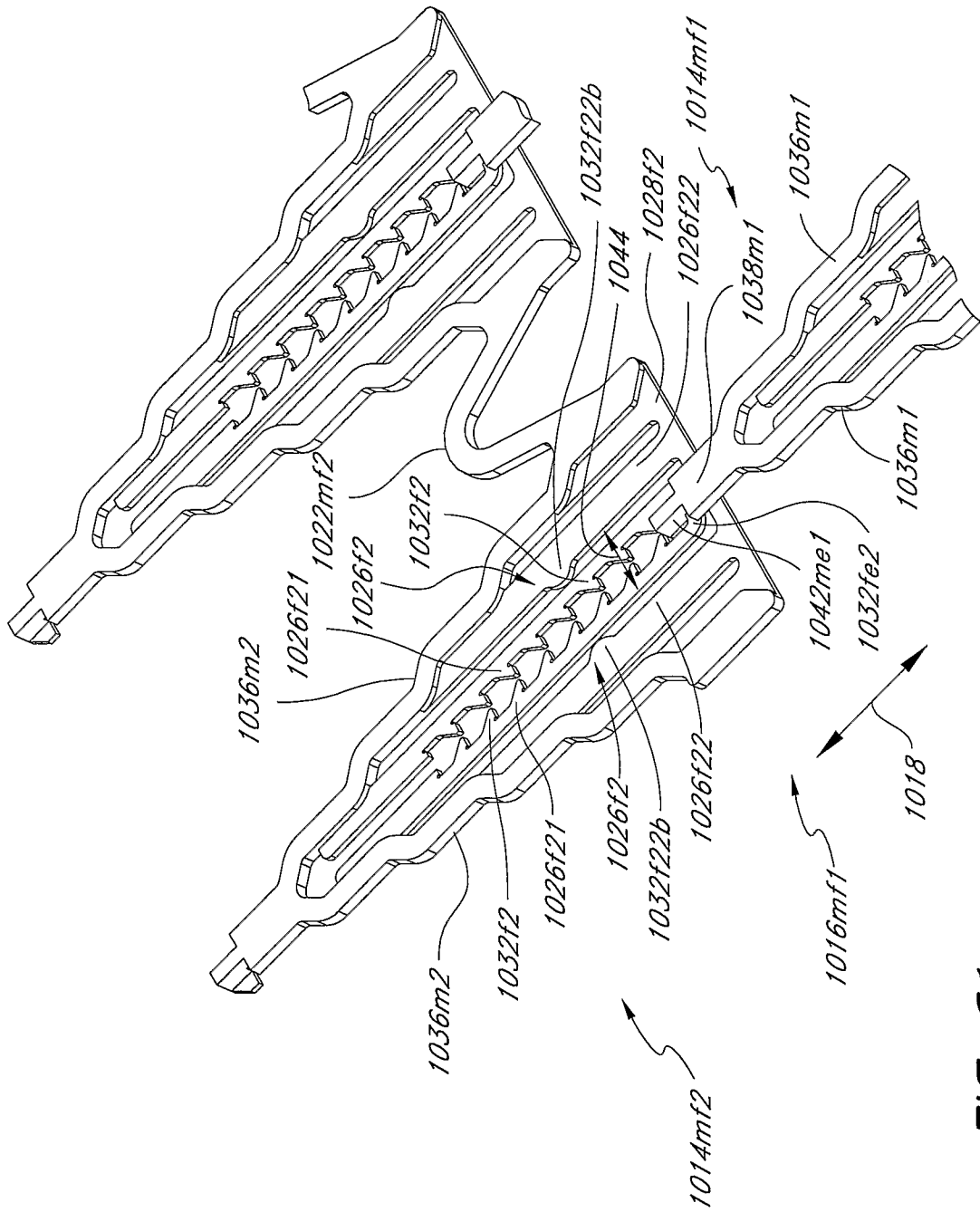

FIG. 61

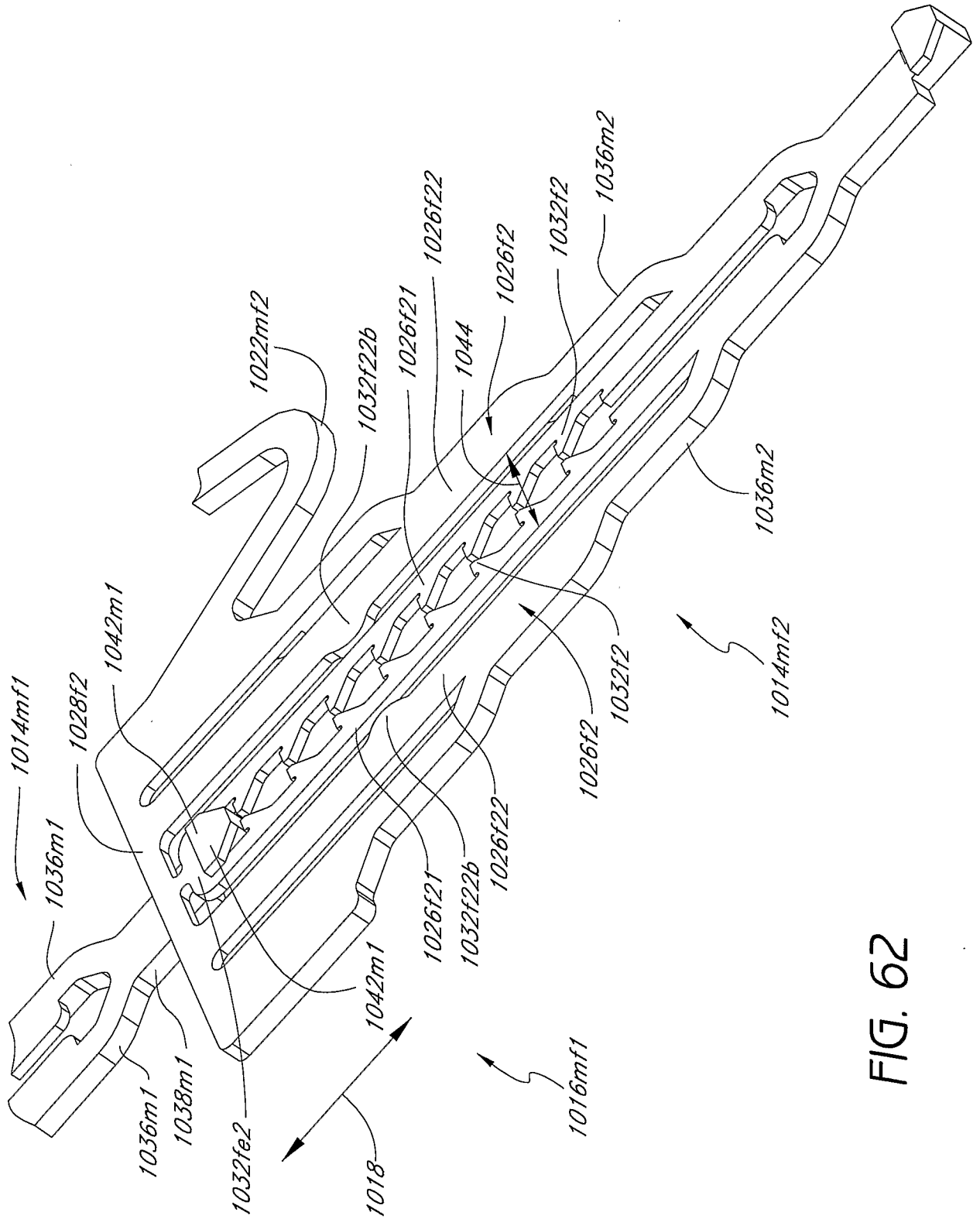

FIG. 62

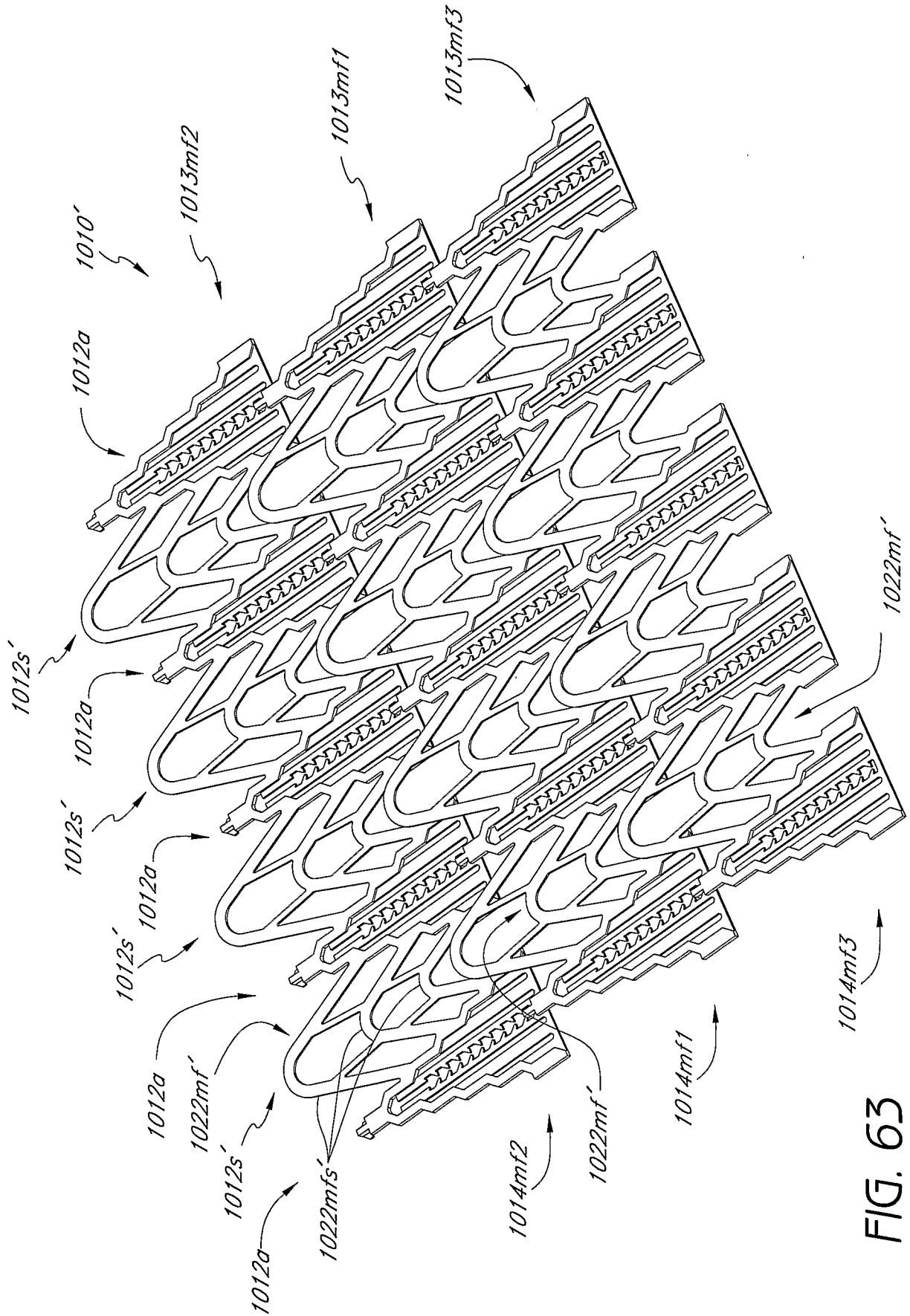

FIG. 63

INTERNATIONAL SEARCH REPORT

International application No
PCT/US2006/029566

A. CLASSIFICATION OF SUBJECT MATTER INV. A61F2/92		
According to International Patent Classification (IPC) or to both national classification and IPC		
B. FIELDS SEARCHED		
Minimum documentation searched (classification system followed by classification symbols) A61F		
Documentation searched other than minimum documentation to the extent that such documents are included in the fields searched		
Electronic data base consulted during the international search (name of data base and, where practical, search terms used) EPO-Internal		
C. DOCUMENTS CONSIDERED TO BE RELEVANT		
Category*	Citation of document, with indication, where appropriate, of the relevant passages	Relevant to claim No.
E	WO 2006/107608 A (MEDTRONIC VASCULAR INC [US]; CHO JUNGHWA [US]) 12 October 2006 (2006-10-12) paragraph [0019] - paragraph [0033]	1-68
P, X	WO 2006/010636 A (ANGIOMED AG [DE]; BLANK THIEMO [DE]; LORENZ MARKUS [DE]; WACK THILO [D]) 2 February 2006 (2006-02-02) page 9, line 10 - page 21, line 20	1-68
X	WO 02/47582 A2 (MD3 INC [US]; STEINKE THOMAS A [US]; KOENIG DONALD H [US]) 20 June 2002 (2002-06-20) page 6, line 13 - page 24, line 26	1-68
A	US 5 797 951 A (MUELLER EDWARD GENE [US]) 25 August 1998 (1998-08-25) column 2, line 65 - column 5, line 10	1-68
<input type="checkbox"/> Further documents are listed in the continuation of Box C.		
<input checked="" type="checkbox"/> See patent family annex.		
* Special categories of cited documents :		
"A" document defining the general state of the art which is not considered to be of particular relevance	"T" later document published after the international filing date or priority date and not in conflict with the application but cited to understand the principle or theory underlying the invention	
"E" earlier document but published on or after the international filing date	"X" document of particular relevance; the claimed invention cannot be considered novel or cannot be considered to involve an inventive step when the document is taken alone	
"L" document which may throw doubts on priority claim(s) or which is cited to establish the publication date of another citation or other special reason (as specified)	"Y" document of particular relevance; the claimed invention cannot be considered to involve an inventive step when the document is combined with one or more other such documents, such combination being obvious to a person skilled in the art.	
"O" document referring to an oral disclosure, use, exhibition or other means	"&" document member of the same patent family	
"P" document published prior to the international filing date but later than the priority date claimed		
Date of the actual completion of the international search <p style="text-align: center;">7 December 2006</p>	Date of mailing of the international search report <p style="text-align: center;">28/12/2006</p>	
Name and mailing address of the ISA/ European Patent Office, P.B. 5818 Patentlaan 2 NL - 2280 HV Rijswijk Tel. (+31-70) 340-2040, Tx. 31 651 epo nl, Fax: (+31-70) 340-3016	Authorized officer <p style="text-align: center;">Mary, Céline</p>	

INTERNATIONAL SEARCH REPORT

International application No.
PCT/US2006/029566

Box II Observations where certain claims were found unsearchable (Continuation of item 2 of first sheet)

This International Search Report has not been established in respect of certain claims under Article 17(2)(a) for the following reasons:

1. Claims Nos.: **69**
because they relate to subject matter not required to be searched by this Authority, namely:
Rule 39.1(iv) PCT - Method for treatment of the human or animal body by surgery
2. Claims Nos.:
because they relate to parts of the International Application that do not comply with the prescribed requirements to such an extent that no meaningful International Search can be carried out, specifically:
3. Claims Nos.:
because they are dependent claims and are not drafted in accordance with the second and third sentences of Rule 6.4(a).

Box III Observations where unity of invention is lacking (Continuation of item 3 of first sheet)

This International Searching Authority found multiple inventions in this international application, as follows:

1. As all required additional search fees were timely paid by the applicant, this International Search Report covers all searchable claims.
2. As all searchable claims could be searched without effort justifying an additional fee, this Authority did not invite payment of any additional fee.
3. As only some of the required additional search fees were timely paid by the applicant, this International Search Report covers only those claims for which fees were paid, specifically claims Nos.:
4. No required additional search fees were timely paid by the applicant. Consequently, this International Search Report is restricted to the invention first mentioned in the claims; it is covered by claims Nos.:

Remark on Protest

- The additional search fees were accompanied by the applicant's protest.
- No protest accompanied the payment of additional search fees.

INTERNATIONAL SEARCH REPORT

Information on patent family members

International application No

PCT/US2006/029566

Patent document cited in search report	Publication date	Publication date	Patent family member(s)	Publication date
WO 2006107608	A	12-10-2006	NONE	
WO 2006010636	A	02-02-2006	NONE	
WO 0247582	A2	20-06-2002	AU 3083302 A CA 2427270 A1 CN 1529572 A EP 1341481 A2 JP 2004515307 T	24-06-2002 20-06-2002 15-09-2004 10-09-2003 27-05-2004
US 5797951	A	25-08-1998	NONE	