



(11)

EP 3 366 980 A1

(12) **EUROPEAN PATENT APPLICATION**

(43) Date of publication:
29.08.2018 Bulletin 2018/35

(51) Int Cl.:
F21S 8/02 ^(2006.01) **F21V 14/02** ^(2006.01)
F21V 21/30 ^(2006.01) **F21V 15/01** ^(2006.01)
F21V 21/04 ^(2006.01)

(21) Application number: **18158637.1**

(22) Date of filing: **26.02.2018**

(84) Designated Contracting States:
AL AT BE BG CH CY CZ DE DK EE ES FI FR GB GR HR HU IE IS IT LI LT LU LV MC MK MT NL NO PL PT RO RS SE SI SK SM TR
Designated Extension States:
BA ME
Designated Validation States:
MA MD TN

(71) Applicant: **Reggiani S.p.A. Illuminazione**
20845 Sovico, MB (IT)

(72) Inventors:
• **Parravicini, Massimo**
20845 Sovico MB (IT)
• **Festa, Mauro**
20845 Sovico MB (IT)

(30) Priority: **28.02.2017 IT 201700022297**

(74) Representative: **Perani & Partners S.p.A.**
Piazza Armando Diaz, 7
20123 Milano (IT)

(54) **ORIENTABLE LIGHTING DEVICE**

(57) The present invention concerns an orientable lighting unit (1) which comprises a frame (2), configured to be mounted to a ceiling and/or a false ceiling, said frame (2) defining a window (6) facing an area to be illuminated, a lighting unit (7) connected to the frame (2) and adapted to be oriented relative to the frame (2), said lighting unit (7) being at least partially inserted in said window (6); a cover element (11) lying over said window (6) and having an opening (12) with an edge (12a), said edge (12a) surrounding said lighting unit (7) and contacting said lighting unit (7), said opening (12) being allowed to move in said window (6) to afford orientation of said lighting unit (7); a pair of uprights (10), said opening (12) and said lighting unit (7) being disposed between said uprights (10), said lighting unit (7) being further connected and adapted to be tilted relative to said uprights (10). The device is characterized in that the cover element (11) is disposed between said uprights (10), said cover element (11) comprising a pair of half-parts (13) which are connected to and adapted to be moved toward and away from each other.

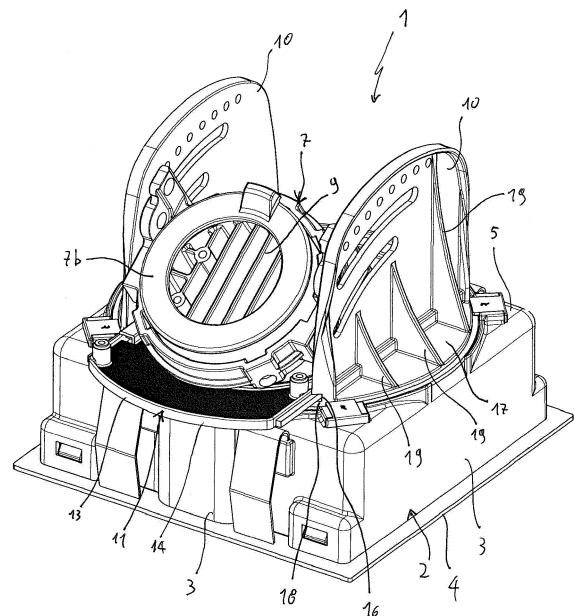

FIG. 1

EP 3 366 980 A1

Description

Technical field

[0001] The present invention relates to a lighting device, which is particularly able to direct a light beam or cone toward an area or an object to be illuminated, as defined in the preamble of claim 1.

[0002] By mere way of example, reference will be made in the present disclosure to a spotlight embedded in a false ceiling, without prejudice to the general scope of the invention.

Background art

[0003] Orientable spotlights are known in the art, and are employed, for example, in shop windows. These spotlights comprise a fixed frame, which is embedded in a false ceiling. A window is formed in the frame.

[0004] A lighting unit is connected to the frame, such that it can be oriented to change the direction through which the light beam is radiated through the aforementioned window. More in detail, a pair of uprights are pivotally connected to the frame, for the aforementioned window to be interposed therebetween. The lighting unit is connected to the uprights and is particularly placed therebetween such that it can be tilted relative to the window.

[0005] The combination of the pivotal movement of the uprights about the window and the tilting movement of the lighting unit allows the light beam to be directed over a wide conical area below the window.

Problem of the prior art

[0006] A problem arises in that the lighting unit does not engage the entire window but is partially inserted therein and defines a wide annular free area. As a result, a person in the vicinity of the lighting device can see parts of the ceiling or false ceiling through the exposed window portion. The window cannot be entirely covered due to the orientable nature of the lighting unit, which must be able to move therein.

[0007] In addition, part of the light emitted from the lighting unit may be radiated backwards, reflected by the ceiling and pass through the window portion that is not engaged by the lighting unit. Such light, which is known as flare, is undesired as it affects the definition of the light beam of the device, that will no longer have the desired shape and direction.

SUMMARY OF THE INVENTION

[0008] Therefore, the technical purpose of the present invention is to provide an orientable lighting device that can obviate the above mentioned prior art drawbacks.

[0009] Particularly, one object of the present invention is to provide an orientable lighting device that can obviate

the flare problem.

[0010] The aforementioned technical purpose and objects are substantially fulfilled by an orientable lighting device that comprises the technical features as disclosed in one or more of the accompanying claims.

Advantages of the Invention

[0011] Particularly, an orientable lighting device of the present invention comprises a frame that is configured to be mounted in a ceiling and/or a false ceiling and/or any type of vertical, horizontal or oblique support. The frame has a window that is designed to face an area to be illuminated.

[0012] The device further comprises a lighting unit which is connected to the frame and can be oriented relative to the frame. This lighting unit is at least partially inserted in the window.

[0013] The device further comprises a cover element, lying over the window. This cover element has an opening with an edge surrounding the lighting unit. In addition, the edge contacts the lighting unit. The opening is further movable in the window, allowing the lighting body to be oriented.

[0014] This device solves the technical problem, as the cover element entirely occludes the window, and has an opening whose size is selected according to the lighting unit. This will still allow orientation of the lighting body, as the opening can accommodate its movements.

LIST OF DRAWINGS

[0015] Further features and advantages of the present invention will result more clearly from the illustrative, non-limiting description of a preferred, non-exclusive embodiment of an orientable lighting device as shown in the annexed drawings, in which:

- Figure 1 is a top perspective view of an orientable lighting device of the present invention;
- Figure 2 is a bottom perspective view of the lighting device of Figure 1;
- Figure 3 is a side view of the lighting device of Figures 1 and 2, with certain parts omitted to better show other parts; and
- Figure 4 is a perspective view of a detail of the lighting device of Figures 1 and 2.

DETAILED DESCRIPTION

[0016] The apparatus of the annexed figures shall be deemed to be schematically illustrated, not necessarily drawn to scale, and not necessarily representing the actual proportions of its parts.

[0017] Although this is not expressly shown, the individual features described with reference to each embodiment shall be intended as auxiliary and/or interchangeable with other features, as described with reference to

other embodiments.

[0018] Referring to the annexed figures, numeral 1 designates an orientable light device of the present invention.

[0019] Reference will be made herein to a space orientation of the device 1 as shown in Figures 1 and 3, i. e. the space orientation of a device fitted in a horizontal ceiling. As used herein, the terms "above", "below" and the like designate the arrangement of the various elements of Figure 1, particularly referring to an orthogonal direction "A" which, if the device 1 is in the position of Figure 1, is vertically oriented. Of course, the device 1 is not limited to the orientation as shown in Figure 1, as it may be also fitted in vertical and/or oblique walls and/or floors. In the latter case, the lighting device 1 will be overturned relative to the orientation of Figure 1.

[0020] The device comprises a frame 2, which is configured to be mounted in a ceiling and/or a false ceiling and/or any type of vertical, horizontal or oblique support.

[0021] The frame 2 has a substantially rectangular plan shape and is defined by four walls 3.

[0022] A rim 4 is placed at the base of the walls 3, and a bottom 5 is placed at the top of the walls 4.

[0023] In the embodiment as shown for example in Figure 1, the frame 2 is designed to be fitted in a seat (not shown), in which most of it is hidden from view.

[0024] Particularly, the walls 3 and the bottom 5 are hidden from view, and the rim 4 faces the area to be illuminated and is thus visible.

[0025] The frame 2 supports a lighting unit 7. Such lighting unit can be oriented relative to the frame 2, i.e. a tilt angle and an azimuth angle thereof relative to the frame can be changed.

[0026] The lighting unit 7 has a substantially prismatic, particularly a cylindrical shape, and has first 7a and second 7b opposite ends.

[0027] The first end 7a is open and visible from the outside, such that a light source 8, e.g. a bulb, can project a light beam or cone outside the device 1.

[0028] The second end 7b is closed by a grid 9 and, in use, is hidden from view.

[0029] The grid 9 allows the passage of air, to dissipate the heat generated in the lighting unit 7.

[0030] The frame 2 has a window 6, particularly formed at the bottom 5. Such window 6 has a substantially circular shape, and the lighting unit 7 extends therethrough.

[0031] In other words, the lighting unit 7 is at least partially inserted in the window 6.

[0032] The device 1 also comprises a pair of uprights 10.

[0033] These uprights 10 extend along the orthogonal direction "A" away from the frame 2, and particularly from the bottom 5.

[0034] In operation, the uprights 10 are located behind the bottom 5, whereby they are hidden from view.

[0035] The lighting unit 7 is disposed between the uprights 10 and is connected thereto such that its tilt angle relative to the orthogonal direction "A" can be changed.

[0036] Particularly referring to Figure 1, the uprights 10 are placed at the window 6.

[0037] The uprights 10 are fixed to a base 17 which is fitted in the window 6.

5 **[0038]** Reinforcement ribs 19 connect each upright 10 to the base 17 to increase its structural strength.

[0039] It shall be noted that the base 17 can rotate about the orthogonal direction "A", to thereby change the azimuth angle of the lighting unit 7.

10 **[0040]** The device 1 further comprises, also referring to Figure 4, a cover element 11, which lies over the window 6.

[0041] Particularly, the cover element 11 is disposed between the uprights 10.

15 **[0042]** Such cover element 11 has an opening 12, which is movable in the window 6 allowing orientation of the lighting unit 7.

[0043] Particularly, the cover element 11 is also within the window 6, to thereby change the position and shape of the opening 12. Thus, the opening 12 may particularly accommodate the change of tilt of the lighting unit 7 relative to the orthogonal direction "A".

[0044] More in detail, the opening 12 is disposed between the uprights 10.

25 **[0045]** The opening 12 further has an edge 12a. The edge 12a surrounds the lighting unit 7 and preferably contacts the lighting unit 7.

[0046] Particularly referring to Figure 4, it shall be noted that the edge 12a has a shape that mates the shape of the lighting unit 7.

30 **[0047]** Furthermore, as more clearly explained below, the shape of the edge 12 can be changed to remain in contact with the lighting unit 7 with any tilt angle.

[0048] In order to change the shape of the opening 12, the cover element 11 comprises a pair of half parts 13 which are connected together and able to move away/toward each other. Each half part 13 at least partially defines the aforementioned edge 12a.

35 **[0049]** Particularly, each half part 13 has a concave semicircular profile 13a defining part of the edge 12a of the opening 12.

[0050] More in detail, the cover element 11 comprises a pair of coplanar, juxtaposed flanges 14. Each flange 14 defines a respective half-part 13.

45 **[0051]** More in detail, the flanges 14 are connected together by at least one elastic element 15, so that they can be moved away/toward each other to accommodate the tilt of the lighting unit 7.

[0052] Preferably, the cover element 11 comprises a pair of elastic elements 15, each defined by a respective spring and connected to both flanges 14.

[0053] The elastic elements 15 surround the opening 12 and hence the lighting unit 7.

50 **[0054]** More in detail, it shall be noted that each upright 10 has a respective guide 16. The guides 16 define a plane parallel to the plane defined by the window 6.

[0055] The cover element 11 fits into the guides 16 of the uprights 10 to slide in the guides 16.

[0056] In other words, the flanges 14 are adapted to slide in the guides 16.

[0057] Each guide 16 is defined by a recess 18 formed in its upright 10 at the aforementioned base 17.

[0058] Therefore, the cover element 11 allows the lighting unit 7 to entirely engage the window 6, thereby preventing the formation of a free annular area. Thus, a person in the vicinity of the lighting device 1 cannot see parts of the ceiling or false ceiling, as the cover element 11, and particularly its half-parts 13 are always in contact with the lighting unit 7, at any tilt angle assumed by the lighting unit.

[0059] Furthermore, since the half-parts 13 of the cover element 11 are movable relative to each other, the window 6 can be always entirely covered, even when the lighting unit 6 is moved in the desired direction.

[0060] Those skilled in the art will obviously appreciate that a number of changes and variants as described above may be made to fulfill particular requirements, without departure from the scope of the invention, as defined in the following claims.

Claims

1. An orientable lighting device (1), comprising:

- a frame (2) configured to be mounted in a ceiling and/or a false ceiling, said frame (2) defining a window (6) facing an area to be illuminated;
- a lighting unit (7) connected to the frame (2) and adapted to be oriented relative to the frame (2), said lighting unit (7) at least partially fitting in said window (6);
- a cover element (11) lying over said window (6) and having an opening (12) with an edge (12a), said edge (12a) surrounding said lighting unit (7) and contacting said lighting unit (7), said opening (12) being allowed to move in said window (6) to control the orientation of said lighting unit (7);
- a pair of uprights (10), said opening (12) and said lighting unit (7) being disposed between said uprights (10), said lighting unit (7) being further connected and adapted to be tilted relative to said uprights (10);

characterized in that said cover element (11) is disposed between said uprights (10), said cover element (11) comprising a pair of half-parts (13) which are connected to and adapted to be moved toward and away from each other.

2. A device (1) as claimed in claim 1, wherein said cover element (11) is allowed to move within the window (6) to change the position and shape of said opening (12).

3. A device (1) as claimed in any of the preceding claim 1 or 2, wherein each half-part (13) at least partially defines said edge (12a).

4. A device (1) as claimed in claim 1, wherein said cover element (11) comprises a pair of flanges (14), each flange (14) defining a respective half-part (13); said flanges (14) being arranged in coplanar and juxtaposed relationship.

5. A device (1) as claimed in claim 4, wherein said flanges (14) are connected by at least one elastic member (15) to accommodate the tilt of said lighting unit (7).

6. A device (1) as claimed in any of claims 1 to 5, wherein each upright (10) has a respective guide (16), said cover element (11) fitting in said guides (16) and sliding within said guides (16).

7. A device (1) as claimed in claim 6, wherein said guides (16) define a plane parallel to said window (6).

8. A device (1) as claimed in claim 6 or 7, wherein each guide (16) is defined by a recess (18) situated at a base (17) of its respective upright (10).

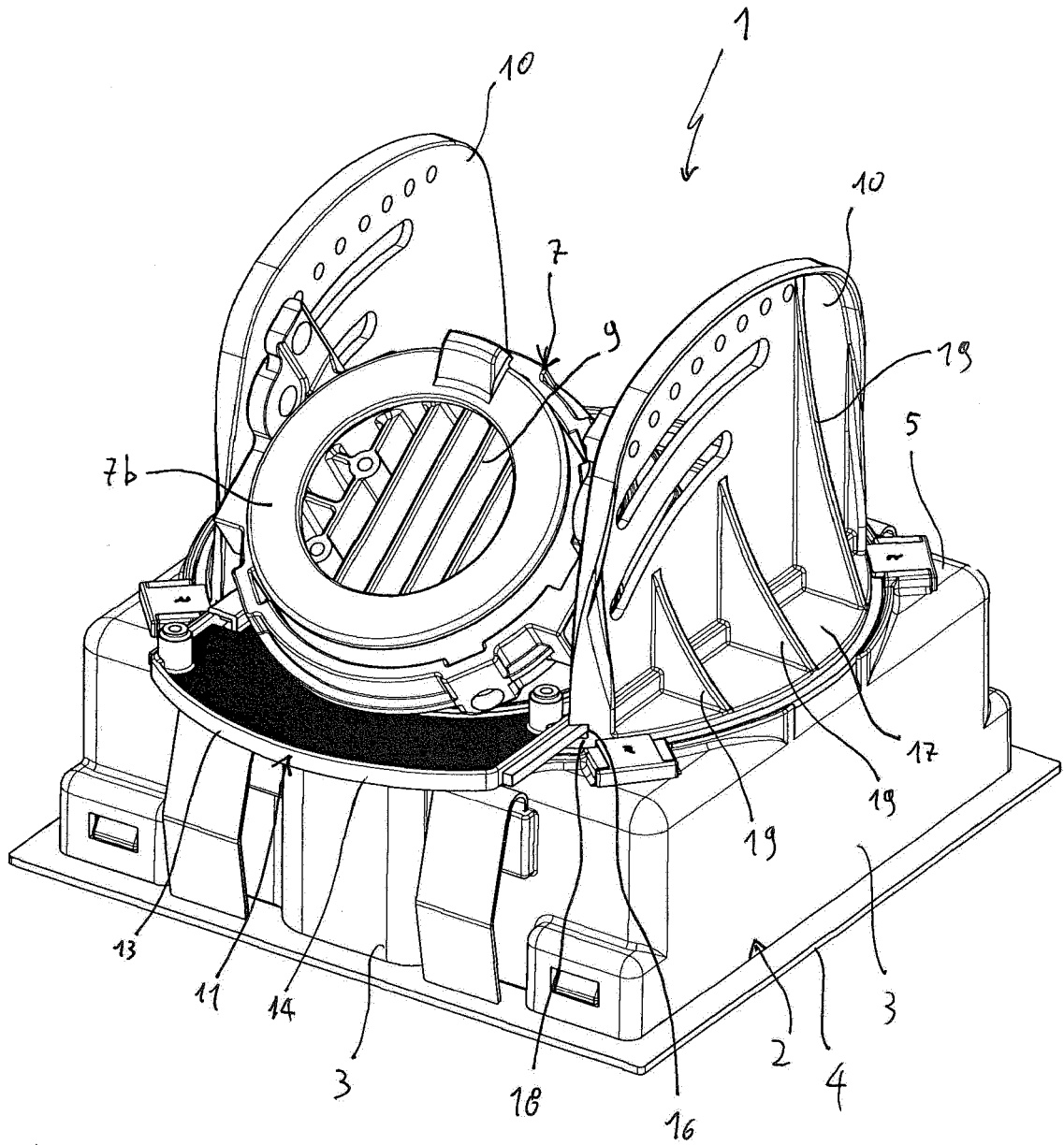

FIG. 1

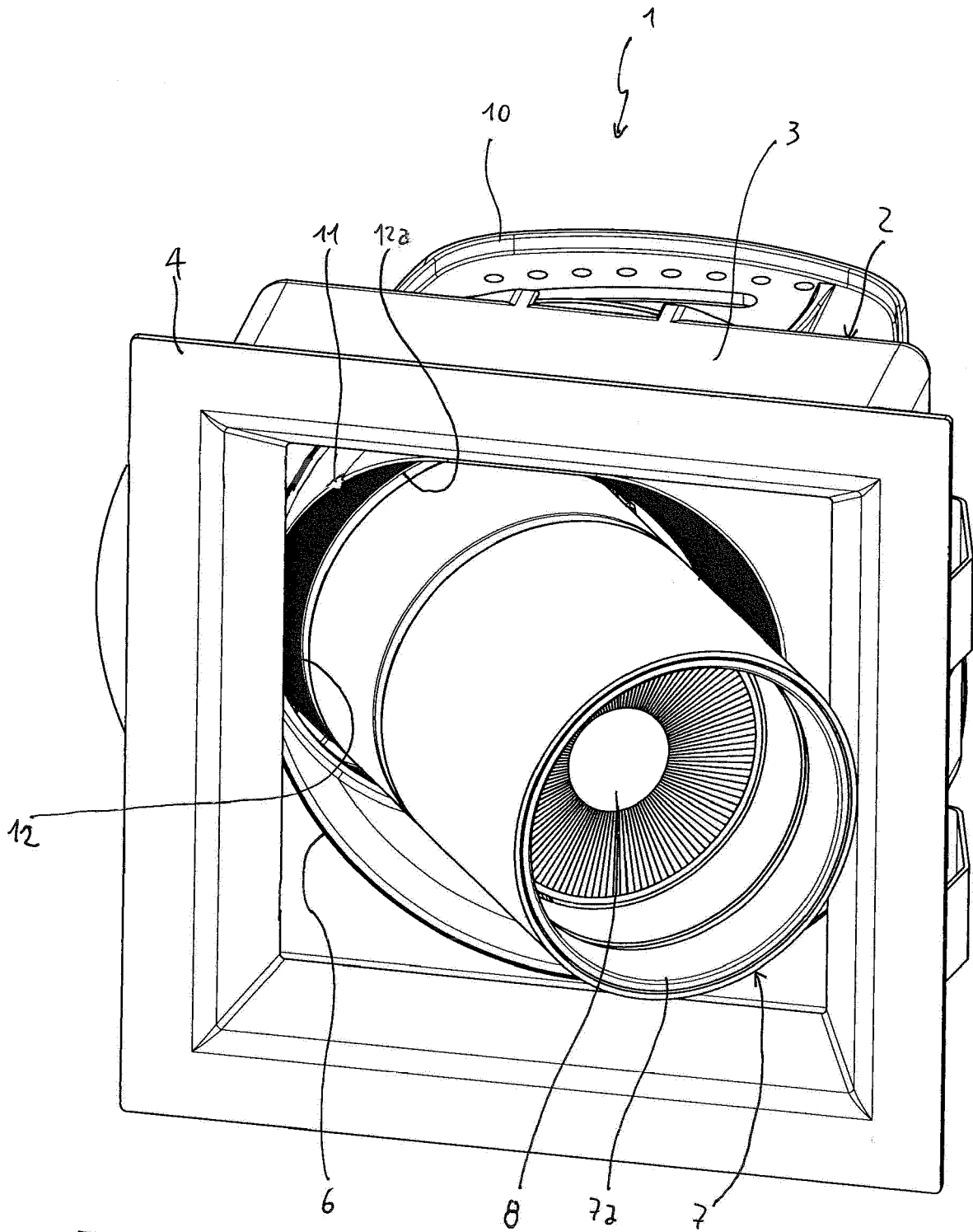

FIG. 2

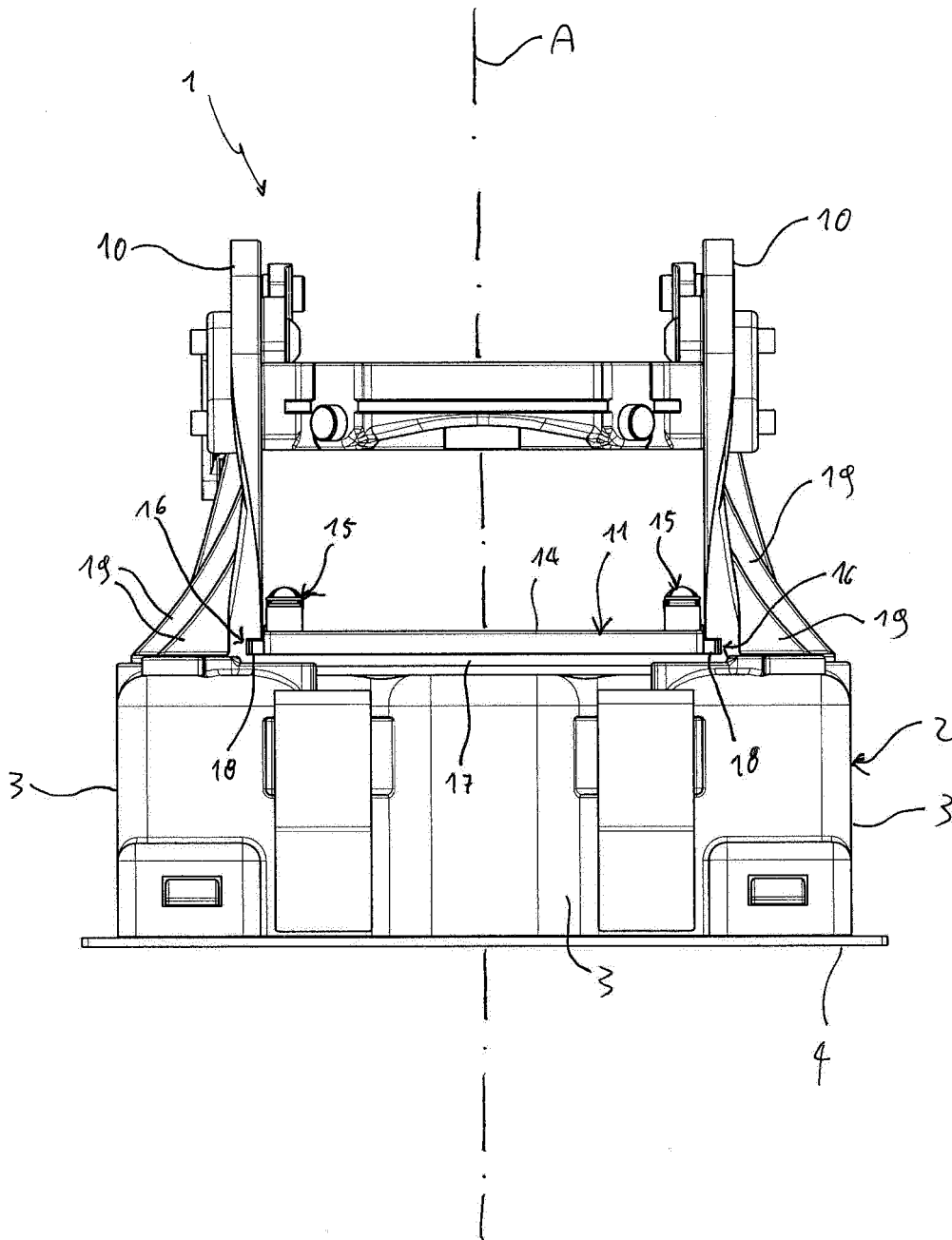

Fig. 3

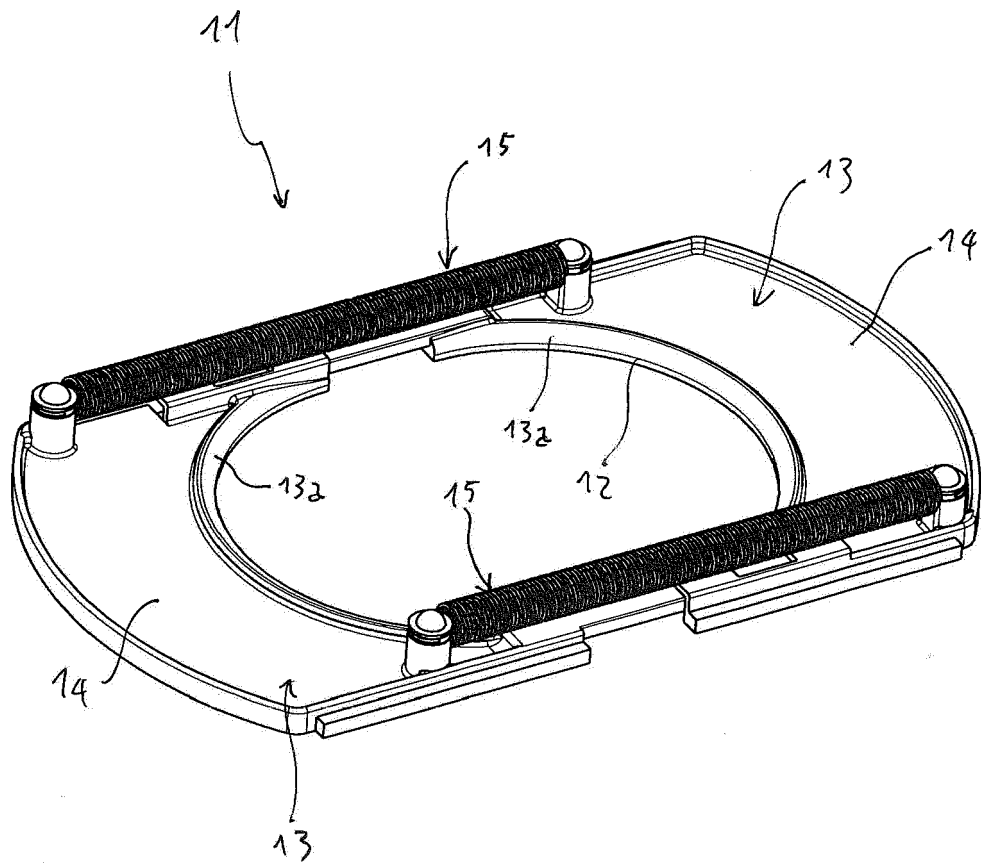

FIG. 4



EUROPEAN SEARCH REPORT

Application Number
EP 18 15 8637

5

10

15

20

25

30

35

40

45

50

55

DOCUMENTS CONSIDERED TO BE RELEVANT			
Category	Citation of document with indication, where appropriate, of relevant passages	Relevant to claim	CLASSIFICATION OF THE APPLICATION (IPC)
A	US 6 832 845 B1 (KRETZSCHMAR THOMAS E [US] ET AL) 21 December 2004 (2004-12-21) * column 10, line 25 - line 33 * * column 11, line 22 - column 13, line 37 * * figures 22-29 *	1-8	INV. F21S8/02 F21V14/02 F21V21/30
A	EP 0 845 633 A1 (ZEBULON [FR]) 3 June 1998 (1998-06-03) * column 2, line 27 - column 3, line 22 * * figures 1-4 *	1-8	ADD. F21V15/01 F21V21/04
A	WO 2017/006289 A1 (AURORA LTD [GB]) 12 January 2017 (2017-01-12) * page 5, line 25 - page 7, line 7 * * figures 1-5,8,9 *	1-8	
A	US 2015/345761 A1 (LAWLOR MICHAEL [US]) 3 December 2015 (2015-12-03) * paragraph [0057] - paragraph [0076] * * figures 8-18 *	1-8	
A	JP S61 204843 U (UNKNOWN) 24 December 1986 (1986-12-24) * the whole document *	1-8	TECHNICAL FIELDS SEARCHED (IPC) F21S F21V
A	JP S50 16244 A (UNKNOWN) 20 February 1975 (1975-02-20) * the whole document *	1-8	
The present search report has been drawn up for all claims			
Place of search The Hague		Date of completion of the search 26 June 2018	Examiner Soto Salvador, Jesús
CATEGORY OF CITED DOCUMENTS X : particularly relevant if taken alone Y : particularly relevant if combined with another document of the same category A : technological background O : non-written disclosure P : intermediate document T : theory or principle underlying the invention E : earlier patent document, but published on, or after the filing date D : document cited in the application L : document cited for other reasons & : member of the same patent family, corresponding document			

EPO FORM 1503 03.02 (P04C01)

ANNEX TO THE EUROPEAN SEARCH REPORT
ON EUROPEAN PATENT APPLICATION NO.

EP 18 15 8637

5

This annex lists the patent family members relating to the patent documents cited in the above-mentioned European search report. The members are as contained in the European Patent Office EDP file on
The European Patent Office is in no way liable for these particulars which are merely given for the purpose of information.

26-06-2018

10

15

20

25

30

35

40

45

50

55

Patent document cited in search report	Publication date	Patent family member(s)	Publication date
US 6832845	B1	21-12-2004	NONE
EP 0845633	A1	03-06-1998	EP 0845633 A1 03-06-1998 FR 2756613 A1 05-06-1998
WO 2017006289	A1	12-01-2017	AU 2016290994 A1 08-02-2018 CN 108027133 A 11-05-2018 EP 3320260 A1 16-05-2018 GB 2540277 A 11-01-2017 WO 2017006289 A1 12-01-2017
US 2015345761	A1	03-12-2015	NONE
JP S61204843	U	24-12-1986	NONE
JP S5016244	A	20-02-1975	NONE

EPO FORM P0459

For more details about this annex : see Official Journal of the European Patent Office, No. 12/82