

E. F. TOOMY.  
MAIL BOX.  
APPLICATION FILED JULY 14, 1909.

997,478.

Patented July 11, 1911.

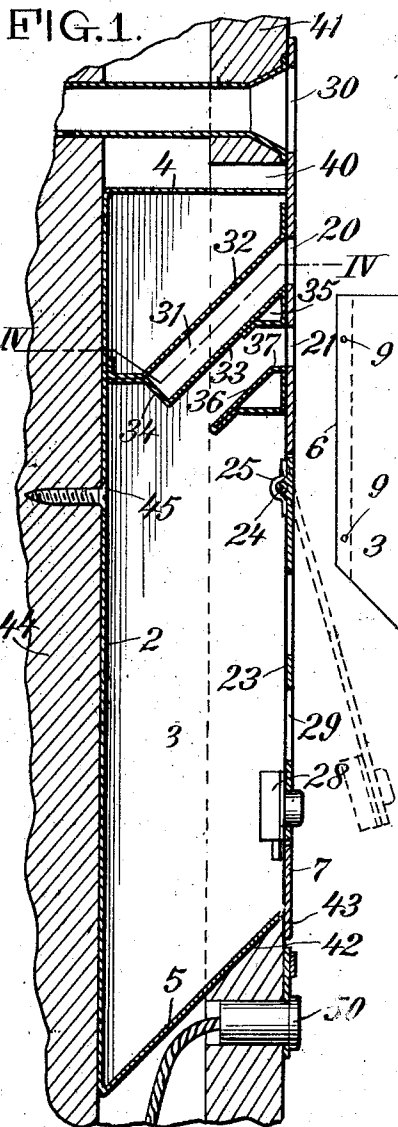

FIG. 2.

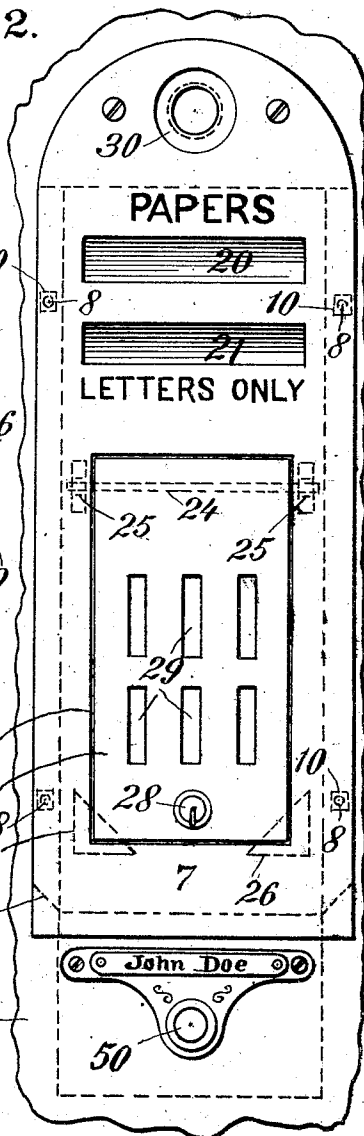

FIG. 3.

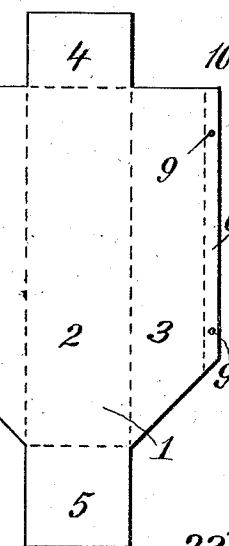
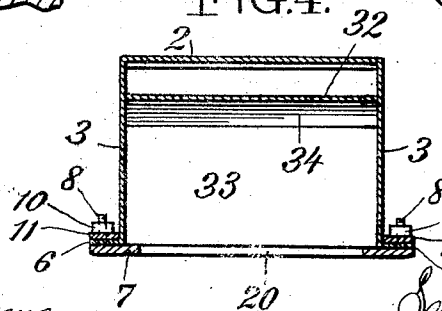

FIG. 4.



Witnesses:  
*Oliver Williams*  
*Edmund James Moses*

*Edmond J. Toomy*  
Inventor  
*Edward Davis*  
By his Attorney.

# UNITED STATES PATENT OFFICE.

EDMOND F. TOOMY, OF JERSEY CITY, NEW JERSEY.

MAIL-BOX.

997,478.

Specification of Letters Patent. Patented July 11, 1911.

Application filed July 14, 1909. Serial No. 507,495.

To all whom it may concern:

Be it known that I, EDMOND F. TOOMY, a citizen of the United States, residing at Jersey City, in the county of Hudson and State of New Jersey, have invented certain new and useful Improvements in Mail-Boxes, of which the following is a specification.

My invention relates to mail or letter boxes and is especially applicable to boxes designed for receiving mail delivered at private residences or apartment houses, although it will be obvious that certain features of the invention are of more general application.

Among the objects of my invention are, the construction of a mail box in which separate receptacles are provided for the reception of letters and newspapers and from which the removal of letters without opening the door in the regular manner is made impossible.

My invention also embodies several improvements in structure which combine in producing a box easy to manufacture and to install and of great strength and durability.

In the accompanying drawings, which form a part of this specification, Figure 1 is a transverse vertical sectional view of a box, showing its inner construction and its method of attachment to the wall. Fig. 2 is a front view of the box in place. Fig. 3 is a view on a reduced scale of the blank from which the body of the box is constructed and Fig. 4 is a horizontal sectional view taken on the line IV—IV of Fig. 1.

In these drawings I have shown one modification of my invention, which I have chosen for purposes of illustration, but I do not wish to be understood as limiting myself to this specific construction as numerous changes may be made therein.

Referring to the drawings in detail, the body of the box is preferably formed from a single blank of metal 1, bent to form a back 2, with the sides 3, top 4 and bottom 5. The latter may be inclined at an acute angle to the back of the box, as shown, in order to throw the letters dropped into the box forward and facilitate their removal. The edges of the sides 3 are preferably turned outwardly to form flanges 6 to which the front of the box is secured.

7 is the box front, which may be secured to the body of the box in various ways, but preferably by means of studs 8 cast integral therewith, which project from its rear

face through holes 9 in the flanges 6. Nuts 10 secure the flanges to the studs, reinforcing strips 11 preferably being interposed between the nuts and the flanges. The front plate is provided with an opening 20 for newspapers, an opening 21 for letters, and a large opening 22, closed by a door 23, for the removal of the letters. This door I prefer to hinge at or near the top, as by so doing it is made self-closing and cannot be left standing open and in danger of being torn off as may and frequently does happen where the door is hinged at the bottom, or at one side. The door has secured to its rear face a rod 24 which projects at each side, forming trunnions which turn in bearings 25 secured to or formed upon the front plate. A satisfactory hinge is thus produced, though it is obvious that I may, if desired, use any other type of hinge. Abutments 26 are secured to or formed upon the inner face of the front plate 7, to limit the inward movement of the door. Secured to the lower part of the door is a lock 28. Slots 29 are preferably cut in the door to permit inspection of the interior of the box without opening the latter. The front plate may also be provided with an aperture 30 for a speaking tube.

Within the body of the box and opposite the newspaper opening 20, I form a newspaper receiving pocket 31. This pocket is preferably formed of a top piece 32 and a bottom piece 33, the bottom piece being bent up to form the end of the pocket 34. This bottom piece may also be bent into a loop 35 at its forward end, the doubled over portion acting as a reinforcing member for the bottom of the pocket as well as for the portion of the front plate separating the newspaper and letter openings. This newspaper pocket is designed to admit only a portion of a newspaper, being large enough to permit the insertion of the end of a folded paper by letter carrier or newsboy, and thus avoiding the usual clogging of the letter slot with newspapers. At the same time, the size of the box is not materially increased by the addition of this feature, as is the case where a receptacle for entire newspapers is provided. Below the letter opening is placed a guard piece 36, preferably extended horizontally for a short distance, as shown at 37, and then sloping downwardly at an angle of about forty-five degrees and parallel with the bottom 33 of the news-

paper pocket. A narrow inclined channel for the reception of letters is thus formed which permits them to be easily inserted, but prevents the entrance of the fingers or of an instrument for their surreptitious removal. The guard 36 is preferably formed of a single piece of metal doubled upon itself for a part of its length and then formed into an open tube to give added strength.

10 These pieces 32, 33 and 36 are secured to the sides of the box by soldering or in any suitable manner. If desired, they may be provided with tongues passing through slots cut in the boxes' sides, the tongues being

15 bent over on the outside.

In mounting the box in the wall an opening 40 is formed in the outer facing 41 of a sufficient size to admit the box, the bottom of the opening being preferably inclined as

20 shown at 42 to fit the inclined bottom of the box. The front plate 7 is preferably extended slightly below the bottom of the box as at 43 to engage the outer face of the wall. The back of the box preferably rests against

25 the studding or other backing 44, to which it is secured by a screw 45, or in any other suitable manner. By fitting the box in the opening 40 with the inclined bottom resting against the inclined face 42, it is firmly sustained in position and a single screw is sufficient to prevent its removal. As the head

30 of this screw is in the interior of the box, it is obvious that it cannot be taken out without opening the latter, and the removal

35 of the entire box by unauthorized persons

is thus prevented. Beneath the inclined bottom 5 a triangular space is left for the insertion of the electric door bell or mail signal button 50, the wires from which are passed beneath the box. The passage of wires through the box and the taking up of the space of the latter with the push button is thus avoided.

Having thus described my invention, I claim:

1. In a mail box, a shallow newspaper pocket having a stationary inclined bottom, a letter receptacle below said pocket, the front of said mail box being provided with a pair of parallel slots, one opposite said newspaper pocket, and one forming a letter drop for the insertion of letters into said receptacle, the fixed inclined bottom of said pocket forming a guard for said letter drop, and an inclined guard piece substantially parallel with the fixed bottom of said pocket, mounted in said box below said letter drop.

2. In a letter box comprising a back and sides, a shallow stationary newspaper pocket comprising a top piece, secured to said back and sides, and a bottom piece secured to said top piece and to said sides, said bottom piece having an end offset to form an end for said pocket.

EDMOND F. TOOMY.

Witnesses:  
 EDMUND QUINCY MOSES,  
 OLIVER WILLIAMS.