

May 23, 1961

A. J. GALE

2,985,760

COMPACT NEUTRON SOURCE

Filed Sept. 12, 1958

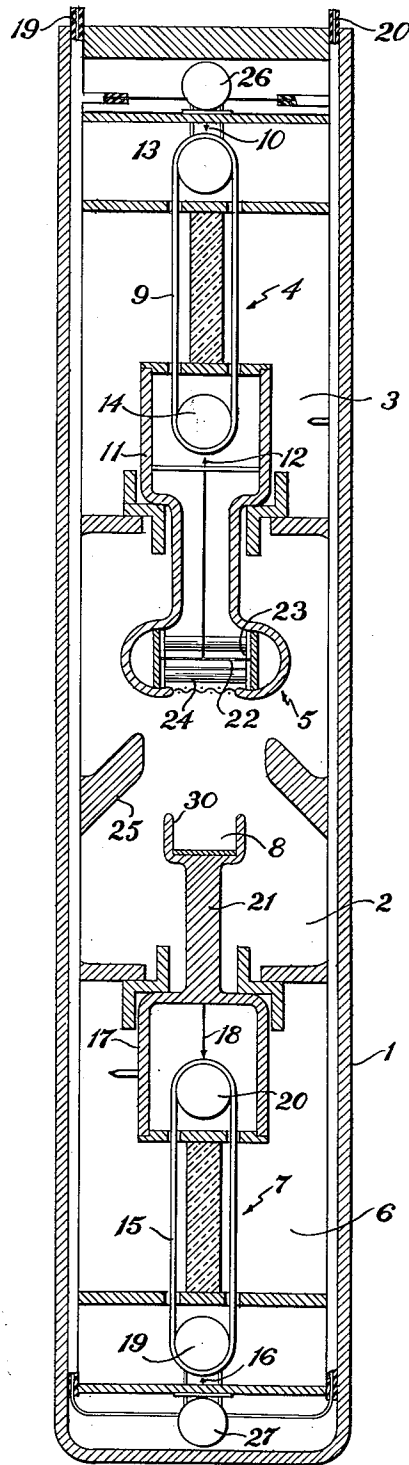

1

2,985,760

COMPACT NEUTRON SOURCE

Alfred J. Gale, Lexington, Mass., assignor to High Voltage Engineering Corporation, Burlington, Mass., a corporation of Massachusetts

Filed Sept. 12, 1958, Ser. No. 760,705

1 Claim. (Cl. 250—84.5)

This invention relates to neutron sources, and in particular to a compact neutron source adapted for use in regions having limited volume and to which only a limited amount of power can be delivered, such as boreholes. The invention is particularly suited for use in well-logging and constitutes an improvement upon the invention described and claimed in my co-pending application, Serial No. 515,435 filed June 14, 1955, now U.S. Patent No. 2,907,844 issued October 6, 1959, and assigned to the assignee of the present invention.

Broadly stated, the invention comprises a compact neutron source of the type described in the aforementioned application, wherein the positive ion source is at a positive voltage with respect to the surroundings and the target at a negative voltage with respect to the surroundings so that the total voltage difference between the target and the positive ion source is the sum of these two voltages. The positive ion source and the target are spaced from each other along the longitudinal axis of the neutron source. Such an arrangement has the important result that it reduces the radial voltage between the axis and the boundary of the ion-acceleration chamber to one half the total voltage required for ion acceleration.

The invention may best be understood from the following detailed description thereof, having reference to the accompanying drawing in which the single figure is a view in longitudinal central section showing somewhat diagrammatically the principal portions of a neutron source constructed in accordance with the invention.

Referring to the drawing, the device therein shown may be constructed along the general lines disclosed in the aforementioned co-pending application. The entire neutron source constructed in accordance with the invention may be enclosed in a housing 1 of generally cylindrical configuration and in the device shown in the figure the housing 1 is particularly adapted to be lowered down a borehole. The housing 1 is of conductive material and is at ground potential. The interior of the housing 1 is divided into three main compartments. The neutron source proper is housed in the middle compartment 2. The upper compartment 3 houses a voltage generator 4 which maintains the ion source 5 at a high positive potential. The lower compartment 6 houses a second voltage generator 7 which maintains the target 8 at a high negative potential. In operation, the upper and lower compartments 3, 6 are filled with a gas under pressure in order to insulate the various high voltage parts of the apparatus from the grounded housing 1. In operation the middle compartment 2 is filled with an appropriate gas at very low pressure. These three compartments 2, 3, 6 are therefore hermetically closed off from the surrounding atmosphere and from each other.

As is fully set forth in the aforementioned co-pending application, electrostatic belt-type generators are particularly well suited as the voltage source for compact neutron sources of the type with which the invention is concerned. The operation of electrostatic belt-type generators is well

2

known, and it is sufficient herein to state that positive charge is deposited on the endless insulating belt 9 of the first electrostatic belt-type generator 4 by a corona discharge from the charge-spray points 10, and after the belt 9 has carried this positive charge to within a hollow electrode or high voltage terminal 11, the positive charge is removed from the belt 9 by the charge-collector points 12. The belt 9 is supported upon a substantially grounded pulley 13 and a high-voltage pulley 14, which is located within the hollow electrode 11. In a similar manner negative charge is deposited on the belt 15 of the second electrostatic belt-type generator 7 by the charge-spray points 16, and the belt 15 conveys this negative charge to within a second hollow electrode 17 where the negative charge is removed from the belt 15 by the charge-collector points 18. The belt 15 is supported upon a substantially grounded pulley 19 and a high-voltage pulley 20, which is located within the hollow electrode 17. In this manner, the first hollow electrode 11 may be maintained at +100 kilovolts and the second hollow electrode 17 at -100 kilovolts. There is thus a potential difference between the ion source 5 and the target 8 of 200 kilovolts. However, the radial insulation required between the high voltage parts of the apparatus and the grounded housing 1 does not exceed 100 kilovolts. The target 18 is adapted to produce neutrons upon bombardment with positive ions and is affixed to an extension 21 of the hollow electrode 17 so as to be maintained at the high negative potential of the hollow electrode 17.

The construction of the ion source 5 is fully described in the aforementioned co-pending application and need not be described herein in any detail. Suffice it to say herein that said ion source 5 comprises a central filament 22 to which electrons are attracted from a source of electrons 23. The source of electrons 23 may comprise an apertured disk which is at the potential of the hollow electrode 11 as is fully described in a co-pending application, Serial No. 623,337 filed November 20, 1956. The current which is collected by the collector points 12 within the high voltage terminal 11 is delivered directly to the filament 22, so that there is a potential difference between the filament 22 and the apertured disk 23 of such polarity as to accelerate electrons towards the filament 22. These electrons are caused to travel very long paths by virtue of the magnetic field produced by the magnets 24 so that ionization is produced within the ion source 5. Some of these ions are then accelerated towards the target 8 by virtue of the electric field produced by the voltage difference between the ion source 5 and the target 8. At least one field-shaping electrode, such as the truncated hollow cone at ground potential shown at 25, should be provided so that the ion-accelerating field is such as not only to accelerate the ions towards the target 8, but also to focus them thereon. As is described more fully in the aforementioned co-pending application, the entire power for operating the neutron source is derived through electric motors 26 and 27 which drive the electrostatic belt-type generators 4 and 7, respectively. Electrical power is supplied to the motors 17, 18 by power leads 28 and 29.

In order to reduce loading the device by secondary emission of electrons from the target 8, a Faraday cup 30 is provided to shape the electric field in the vicinity of the target 8 and assist in collecting the secondary electrons. The longitudinal length of the Faraday cup 30 should preferably be about three times the inner diameter thereof. (It will be apparent that in the figure of the drawing, the Faraday cup 30 has been somewhat shortened longitudinally merely in order to simplify the drawing.)

Having thus described the principles of the invention together with an illustrative embodiment thereof, it is to

3

be understood that although specific terms are employed they are used in a generic and descriptive sense and for purposes of limitation, the scope of the invention being set forth in the following claim.

I claim:

A compact neutron source adapted for use in regions having limited volume and to which only a limited amount of power can be delivered such as boreholes, comprising in combination a grounded enclosure, a positive ion source supported within said grounded enclosure, a target supported within said grounded enclosure and spaced from said positive ion source along the longitudinal axis of said enclosure, a voltage generator for maintaining said positive ion source at a positive voltage with respect to said enclosure, a voltage generator for

4

maintaining said target at a negative voltage with respect to said enclosure so that the total voltage differences available for ion acceleration is the sum of said two voltages, each of said voltage generators being operated by mechanical power, and means for delivering mechanical power to each of said voltage generators.

5

References Cited in the file of this patent

UNITED STATES PATENTS

2,231,622	Graves	Feb. 11, 1941
2,368,798	Ball	Feb. 6, 1945
2,769,096	Frey	Oct. 30, 1956
2,842,695	Goodman	July 8, 1958

10

15