



US00D670550S

(12) **United States Design Patent**  
**Jungklaus et al.**

(10) **Patent No.:** **US D670,550 S**

(45) **Date of Patent:** **\*\* Nov. 13, 2012**

(54) **HANDLE FOR A CONTINUOUS FLOW  
DRYWALL FINISHING TOOL**

D535,539 S 1/2007 Chen  
D540,636 S \* 4/2007 Donner et al. .... D8/61  
D553,465 S 10/2007 Ping

(Continued)

(76) Inventors: **Matthew W. Jungklaus**, Lawrenceville,  
GA (US); **David J. Castagnetta**, Maple  
Grove, MN (US)

*Primary Examiner* — Susan E Krakower  
*Assistant Examiner* — Roselynn Cody  
(74) *Attorney, Agent, or Firm* — Arnall Golden Gregory  
LLP; R. Stevan Coursey, Esq.

(\*\*) Term: **14 Years**

(21) Appl. No.: **29/380,218**

(57) **CLAIM**  
The ornamental design of a handle for a continuous flow  
drywall finishing tool, as shown and described.

(22) Filed: **Dec. 1, 2010**

(51) **LOC (9) Cl.** ..... **08-05**

(52) **U.S. Cl.** ..... **D8/45; D8/107**

(58) **Field of Classification Search** ..... D8/14,  
D8/45, 107; D25/119, 122, 124; 81/489;  
401/51; 425/87

**DESCRIPTION**

See application file for complete search history.

FIG. 1 is a right side perspective view of our handle for a  
continuous flow drywall finishing tool according to our new  
design;

(56) **References Cited**

U.S. PATENT DOCUMENTS

D273,359 S	4/1984	Kolonia	
5,009,730 A *	4/1991	Tozier	156/85
5,088,733 A	2/1992	Barnea et al.	
D375,243 S	11/1996	Hasegawa	
D380,363 S	7/1997	Macor	
D383,049 S	9/1997	Concari et al.	
D387,649 S	12/1997	Concari et al.	
D389,014 S	1/1998	Hasegawa	
D398,463 S *	9/1998	Olson	D6/491
5,882,691 A *	3/1999	Conboy	425/87
5,896,620 A	4/1999	Mink	
D422,869 S	4/2000	Chen	
6,099,203 A *	8/2000	Landes	404/10
6,158,307 A	12/2000	Lamond et al.	
D494,444 S	8/2004	Hung	
D495,934 S *	9/2004	Lin	D8/10
D499,886 S	12/2004	Goulet et al.	
D503,645 S *	4/2005	Wirth et al.	D10/114.9
6,889,405 B2	5/2005	Ritrovato et al.	
D508,570 S *	8/2005	Bouic	D25/121
D513,580 S	1/2006	Lin	

FIG. 2 is a first end elevational view of the handle for a  
continuous flow drywall finishing tool with two bores therein  
extending the length thereof according to our new design;  
FIG. 3 is a second end elevational view of the handle for a  
continuous flow drywall finishing tool according to our new  
design;

FIG. 4 is a left side elevational view of the handle for a  
continuous flow drywall finishing tool according to our new  
design;

FIG. 5 is a right side elevational view of the handle for a  
continuous flow drywall finishing tool according to our new  
design;

FIG. 6 is a top plan view of the handle for a continuous flow  
drywall finishing tool according to our new design;

FIG. 7 is a bottom plan view of the handle for a continuous  
flow drywall finishing tool according to our new design; and,  
FIG. 8 is a sectional view of the handle for a continuous flow  
drywall finishing tool according to our new design, taken  
along lines 8-8 of FIG. 3.

The handle is broken near the center to indicate indeterminate  
length.

**1 Claim, 2 Drawing Sheets**

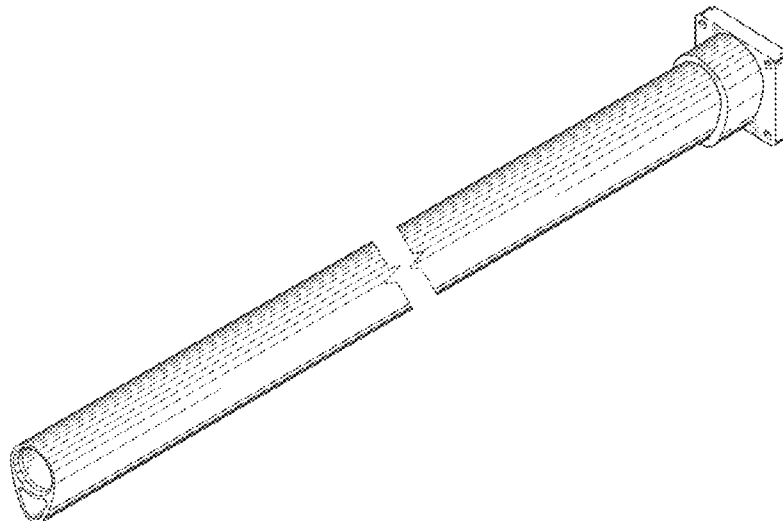

# US D670,550 S

Page 2

## U.S. PATENT DOCUMENTS

D558,444	S	*	1/2008	Ma	.....	D3/6	2001/0003563	A1	*	6/2001	Schauer et al.	.....	401/5
D577,564	S		9/2008	Wu			2003/0072830	A1	*	4/2003	Conboy et al.	.....	425/87
D581,766	S		12/2008	Heneen et al.			2004/0154525	A1	*	8/2004	Wirth et al.	.....	116/1
D603,241	S	*	11/2009	Pearce	.....	D8/107	2005/0100386	A1	*	5/2005	Murray	.....	401/5
7,628,295	B2	*	12/2009	Mondloch et al.	.....	222/397	2005/0155187	A1		7/2005	Ritrovato et al.		
7,779,851	B2	*	8/2010	Mallookis et al.	.....	135/114	2005/0184541	A1	*	8/2005	Grizzle	.....	294/19.1
7,806,613	B2	*	10/2010	Mondloch et al.	.....	401/48	2010/0260879	A1	*	10/2010	Schlecht et al.	.....	425/87
D659,195	S	*	5/2012	Boltz et al.	.....	D20/43							

\* cited by examiner

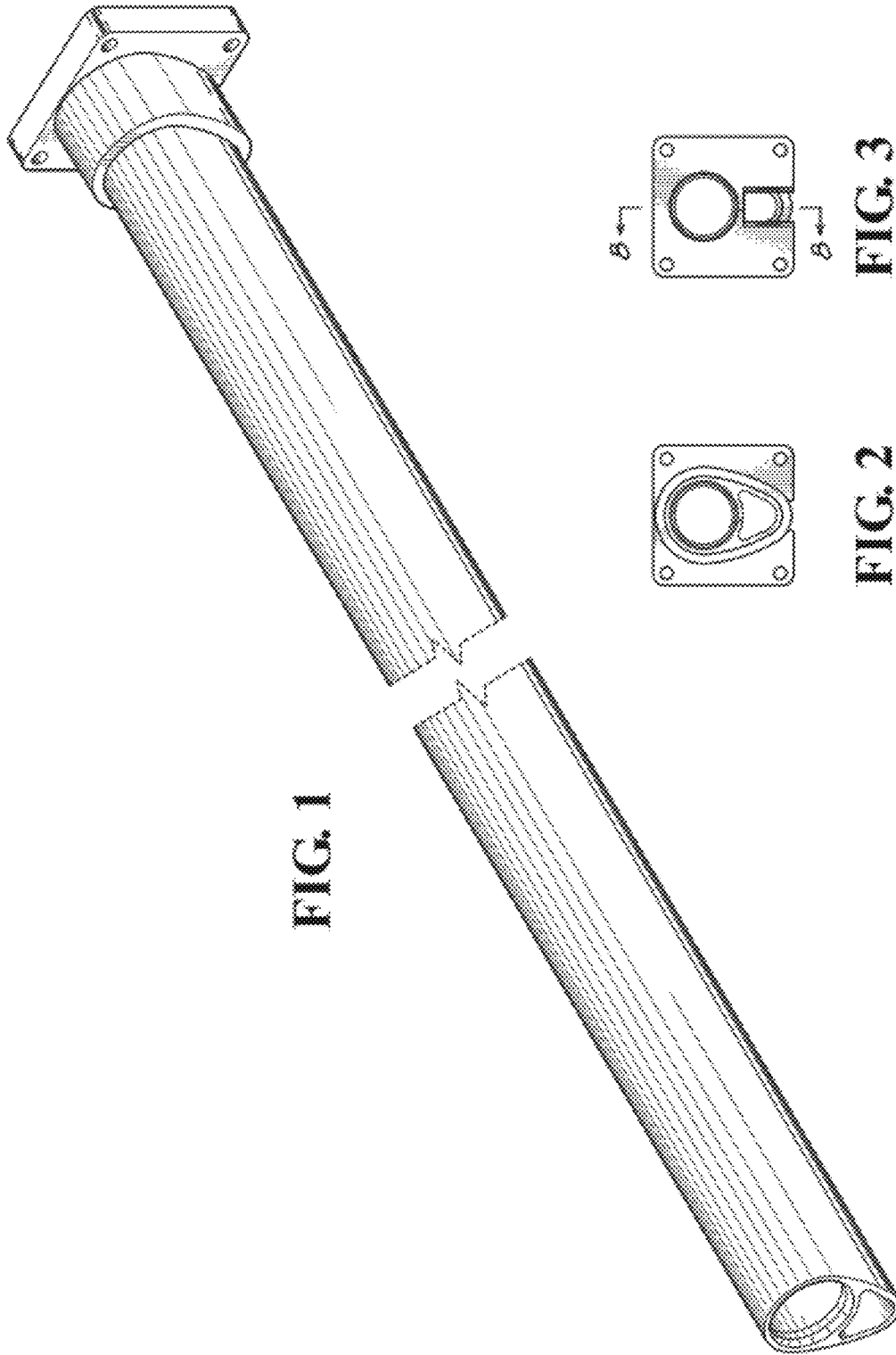

FIG. 1

FIG. 3

FIG. 2

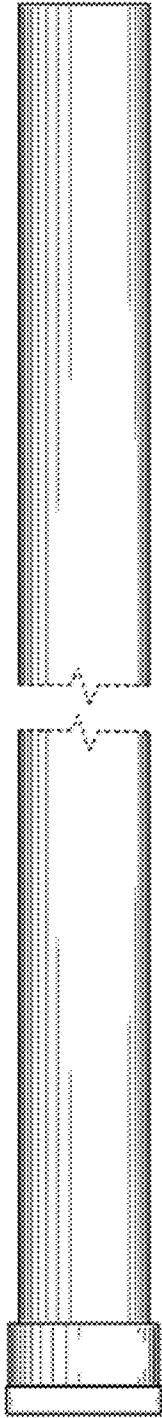

FIG. 4

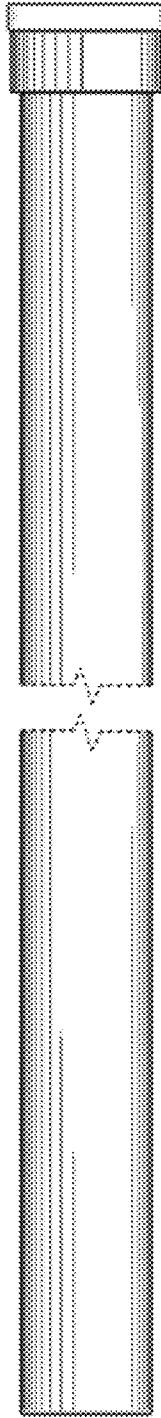

FIG. 5



FIG. 6



FIG. 7

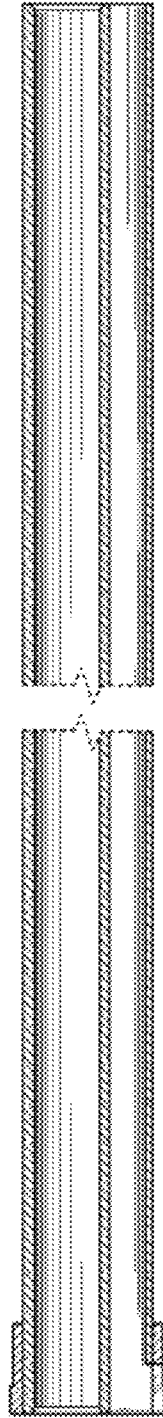

FIG. 8