



INTERNATIONAL APPLICATION PUBLISHED UNDER THE PATENT COOPERATION TREATY (PCT)

|  |           |   |
|--|-----------|---|
| <b>(51) International Patent Classification <sup>5</sup> :</b><br><br><b>G01N 21/85, 15/06</b>   | <b>A1</b> | <b>(11) International Publication Number:</b> <b>WO 91/13340</b><br><br><b>(43) International Publication Date:</b> 5 September 1991 (05.09.91)   |
| <b>(21) International Application Number:</b> PCT/DK91/00053<br><b>(22) International Filing Date:</b> 21 February 1991 (21.02.91)<br><br><b>(30) Priority data:</b><br>503/90 26 February 1990 (26.02.90) DK<br><br><b>(71) Applicant (for all designated States except US):</b> LYS & OPTIK [DK/DK]; Hjortekærvej 99, DK-2800 Lyngby (DK).<br><br><b>(72) Inventors; and</b><br><b>(75) Inventors/Applicants (for US only) :</b> HANSEN, Jan [DK/DK]; Hjortekærvej 125A, DK-2800 Lyngby (DK). NIELSEN, Hans, Ole [DK/DK]; Hjortekærvej 126A, DK-2800 Lyngby (DK). NORTHEVED, Allan [DK/DK]; Skovbakken 56, DK-3520 Farum (DK). |           | <b>(74) Agent:</b> CHAS. HUDE; H.C. Andersens Boulevard 33, DK-1553 Copenhagen V (DK).<br><br><b>(81) Designated States:</b> AT, AT (European patent), AU, BB, BE (European patent), BF (OAPI patent), BG, BJ (OAPI patent), BR, CA, CF (OAPI patent), CG (OAPI patent), CH, CH (European patent), CM (OAPI patent), DE, DE (European patent), DK, DK (European patent), ES, ES (European patent), FI, FR (European patent), GA (OAPI patent), GB, GB (European patent), GR (European patent), HU, IT (European patent), JP, KP, KR, LK, LU, LU (European patent), MC, MG, ML (OAPI patent), MR (OAPI patent), MW, NL, NL (European patent), NO, PL, RO, SD, SE, SE (European patent), SN (OAPI patent), SU, TD (OAPI patent), TG (OAPI patent), US.<br><br><b>Published</b><br><i>With international search report.</i><br><i>With amended claims.</i> |

**(54) Title:** A METHOD OF MEASURING SLURRY**(57) Abstract**

A method of continuously determining the parameters of a fluid, such as the dry-matter percentage in slurry or another industrial product, and whereby said fluid is subjected to a measuring system comprising a radiation source (2) and a radiation detector (3) placed opposite one another, the measuring signals being processed in an evaluation circuit, whereafter the results of the evaluation are displayed on display means (25). The radiation source (2) and the radiation detector (3) are mounted on a forked support immersible in the fluid in question, the source (2) and the detector (3) being subjected to a rinsing simultaneously with the measuring signal being calibrated.

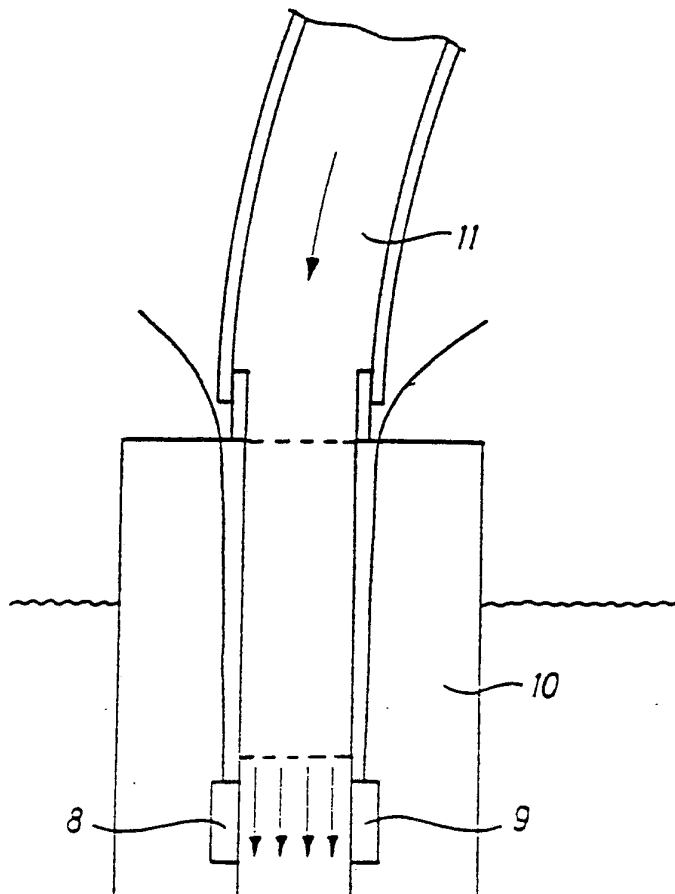

**FOR THE PURPOSES OF INFORMATION ONLY**

Codes used to identify States party to the PCT on the front pages of pamphlets publishing international applications under the PCT.

|    |                          |    |  |    |                          |
|----|--------------------------|----|--|----|--------------------------|
| AT | Austria                  | ES | Spain                                    | MG | Madagascar               |
| AU | Australia                | FI | Finland                                  | ML | Mali                     |
| BB | Barbados                 | FR | France                                   | MN | Mongolia                 |
| BE | Belgium                  | GA | Gabon                                    | MR | Mauritania               |
| BF | Burkina Faso             | GB | United Kingdom                           | MW | Malawi                   |
| BG | Bulgaria                 | GN | Guinea                                   | NL | Netherlands              |
| BJ | Benin                    | GR | Greece                                   | NO | Norway                   |
| BR | Brazil                   | HU | Hungary                                  | PL | Poland                   |
| CA | Canada                   | IT | Italy                                    | RO | Romania                  |
| CF | Central African Republic | JP | Japan                                    | SD | Sudan                    |
| CG | Congo                    | KP | Democratic People's Republic<br>of Korea | SE | Sweden                   |
| CH | Switzerland              | KR | Republic of Korea                        | SN | Senegal                  |
| CI | Côte d'Ivoire            | LI | Licchtenstein                            | SU | Soviet Union             |
| CM | Cameroon                 | LK | Sri Lanka                                | TD | Chad                     |
| CS | Czechoslovakia           | LU | Luxembourg                               | TG | Togo                     |
| DE | Germany                  | MC | Monaco                                   | US | United States of America |
| DK | Denmark                  |    |  |    |                          |

Title: A Method of Measuring Slurry.

Technical Field

The invention relates to a method of continuously determining the parameters of a fluid, such as the dry-matter  
5 percentage in slurry or another industrial product, and whereby said fluid is subjected to a measuring system comprising a radiation source and a radiation detector placed opposite one another, the measuring signals being processed in an evaluation circuit, wherafter the results  
10 of the evaluation are displayed on display means.

Background Art

A system is known for measuring parameter values of a passing fluid. The system comprises a radiation source and a radiation detector optionally in direct contact  
15 with the fluid. Means may furthermore be provided for cleaning the radiation source and the radiation detector. Such means may for instance be in form of a scraper or a jet of wash water.

The known systems are encumbered with the drawback that  
20 it is impossible to maintain clean surfaces and to clean said surfaces to the same extent each time. Accordingly, it is impossible to achieve correct measuring values.

Disclosure of Invention

The object of the invention is to provide a method solving  
25 the above problems.

The method according to the invention is characterised in that the radiation source and the radiation detector are mounted on a forked support immersible in the fluid in question. According to the invention the measuring signal

may be subjected to a simultaneous/following calibration, the source and the detector being subjected to a rinsing.

The radiation used may for instance be provided by light, sound or soft isotopic radiation.

#### 5 Brief Description of Drawings

The invention is described in greater detail below with reference to the accompanying drawings, in which

Fig. 1 illustrates a slurry measuring device comprising a radiation source and a radiation detector placed opposite  
10 one another, the radiation source and the radiation detector being cleaned by means of a rotating scraper,

Fig. 2 illustrates an alternative embodiment, the so-called T-model, of the slurry measuring device, where the scraper is inserted from the side,

15 Fig. 3 illustrates an alternative embodiment of the slurry measuring device, where the probe is bent,

Fig. 4 illustrates a slurry measuring device according to the invention, where the surface of the radiation source and the radiation detector are cleaned by means of passing  
20 water,

Fig. 5 illustrates an example of a measuring signal produced by the slurry measuring device of Fig. 4, and

Fig. 6 illustrates an example of the electronic measuring circuit.

#### 25 Best Mode for Carrying Out the Invention

The invention refers to highly polluted fluids, such as

sludge. An interest has arisen in measuring the dry-matter percentage relative to the water percentage in slurry. The measuring may for instance be carried out by measuring the damping of a suitably selected radiation light, sound or isotopic radiation over a predetermined measuring length. A problem applies, however, because the radiation source and the radiation detector are polluted on the surface with the result that the measuring signal is degraded.

According to a first embodiment, the sludge passes a pipe 1, and the embodiment is provided with two opposing transducers 2, 3 flushing with the inner side of said pipe 1. The inner side of the transducers 2, 3 are kept clean by means of a rotating, cylindrical scraper 4 comprising V-shaped notches. The rotation of the scraper 4 is caused by means of an outer gear wheel engaging said cylindrical, rotating scraper 4 through a slot in the pipe 1. Such an embodiment is, however, encumbered with sealing problems. The scraper 4 may also be formed such that it is caused to rotate by the passing sludge, and then it is provided with inner fins. Alternatively, the scraper 4 can be made of an electrically conductive material and caused to rotate by means of an electromagnetic, rotating field applied from the outside through electromagnets 5 placed on the outside, whereby sealing problems are avoided. Permanent magnets may furthermore be embedded in the rotating scraper 4, said permanent magnets being caused to follow the rotating field. When the rotating scraper is provided with inner fins, the permanent magnets may be used for indicating the flow velocity with the result that it is possible in addition to achieve a measurement of the viscosity which may also be of interest.

According to an alternative embodiment, the so-called T-model shown in Fig. 2, the rotating scraper 22 has been inserted from the side perpendicular to said embodiment. The T-model is advantageous in facilitating the providing

of a rotation by means of a motor 6. The rotating scraper 22 need only be mounted in a liquid-proof manner relative to the motor 6. The driving shaft 21 of the rotating scraper 22 extends through a housing via a liquid-proof bearing, said housing sealingly surrounding the pipe. The transducers 7, 7' are preferably ultrasonic transducers. In addition to the cleaning function, portions of the rotating scraper or a particularly shaped member mounted thereon may be used for calibration.

10 According to the invention, cf. Fig. 4, the radiation source 8 and the radiation detector 9 are mounted on a forked support 10 immersible in the fluid to be measured. Before the calibration, the detector 8 and the radiation source 9 are rinsed by means of rinsing water being fed  
15 through a channel 11 in the forked support 10. The channel 11 may optionally split up into two branch pipes, one branch pipe facing the radiation source 8 and the other branch pipe facing the radiation detector 9. The feeding hose 14 to the channel 11 is provided with a valve controlling the  
20 supply of water. The radiation source 8 is spaced approximately 10 mm from the radiation detector 9. According to the invention a reference measurement is performed, i.e. a calibration, at the end of each rinsing period, and then the actual measuring signal is compared with the reference  
25 signal. In this manner an incomplete cleaning has automatically been taken into account. According to an alternative embodiment, the rinsing channel fills the entire space between the detector 9 and the source 8 with the result that the rinsing fluid functions as a reference fluid  
30 because said rinsing fluid fills the entire volume between the radiation source 8 and the radiation detector 9.

Fig. 5 illustrates an example of measuring signals.

Fig. 6 illustrates an example of the electronic circuit in question, where the transmitter 21 communicates with

the transmitter-transducer 2. The signal received by the receiver-transducer 3 is transmitted to an amplifier 26 in turn transmitting said signal to an amplitude and phase detector 23. Subsequently, the signal is processed in a microprocessor circuit 24 connected to a display 25.

The radiation in question is not necessarily ultrasound. Alternatively, it may be an electromagnetic radiation, such as light or a soft isotopic radiation when heavy metals are to be measured.

10 It is important that the measuring value is compared with the reference value provided at the end of the cleaning process because said comparing turned out to provide sufficiently good measuring results.

The measuring method is in particular used for measuring 15 the dry-matter percentage in sludge by means of infrared light. The method can, however, also be used for other measurements of parameter values of a fluid.

According to another embodiment, the light used is infrared and ultraviolet light. The ultraviolet light is attenuated 20 in response to the amount of organic matter (BOD, COD). Statistically it turned out in addition, that the ratio of infrared to ultraviolet damping is related to the amount of organic matter. Accordingly, a measuring of the attenuation of ultraviolet light relative to infrared light 25 results in the percentage of organic matter in for instance sludge.

The radiation source for emission of both ultraviolet and infrared light may for instance be a halogen or a xenon lamp. The receiving side is provided with a separate 30 detector for infrared light and separate detector for ultraviolet light. The radiation source may be adapted to pulsed operation.

Claims.

1. A method of continuously determining the parameters of a fluid, such as the dry-matter percentage in slurry or another industrial product, and whereby said fluid is  
5 subjected to a measuring system comprising a radiation source and a radiation detector placed opposite one another, the measuring signals being processed in an evaluation circuit, wherafter the results of the evaluation are displayed on display means, c h a r a c t e r i s e d  
10 in that the radiation source and the radiation detector are mounted on a forked support immersible in the fluid in question.
2. A method as claimed in claim 1, c h a r a c t e r -  
i s e d in that the measuring signal is subjected to a  
15 simultaneous/following calibration, the source and the detector being subjected to a rinsing.
3. A method as claimed in claim 1 or 2, c h a r a c -  
t e r i s e d by the radiation being light.
4. A method as claimed in claim 3, c h a r a c t e r -  
20 i s e d by the radiation being infrared light.
5. A method as claimed in claim 3, c h a r a c t e r -  
i s e d by the radiation being ultraviolet light.
6. A method as claimed in claims 4 and 5, c h a r a c -  
t e r i s e d by measuring the ratio of the transmission  
25 of ultraviolet light to infrared light so as to determine the percentage of organic matter.
7. A method as claimed in claims 4 to 6, c h a r a c -  
t e r i s e d in that the light source emitting both  
ultraviolet and infrared light being a halogen or xenon  
30 lamp.

8. A method as claimed in any of the preceding claims,  
c h a r a c t e r i s e d by using a pulsed radiation.

## AMENDED CLAIMS

[received by the International Bureau  
on 24 July 1991 (24.07.91);  
original claims 1-3 replaced by new claim 1;  
claims 4-8 renumbered as claims 2-6 (2 pages)]

1. A method of continuously determining the parameters of a fluid, such as the dry-matter percentage in slurry or an industrial product, and whereby said fluid is subjected to a measuring system comprising a light source and a light detector placed opposite one another, the measuring signals being processed in an evaluation circuit, whereafter the results of the evaluation are displayed on display means, characterised in that the light source and the light detector are mounted on a forked support immersible in the fluid in question, and the measuring signal is subjected to a simultaneous/following calibration, the light source and the light detector being subjected to a rinsing by means of a rinsing channel, filling the entire space between the light detector and the light source, said rinsing fluid simultaneously functioning as a reference fluid.
2. A method as claimed in claim 1, characterised by the light source being an infrared light source.
3. A method as claimed in claim 1, characterised by the light source being an ultraviolet light source.
4. A method as claimed in claims 2 and 3, characterised by measuring the ratio of the transmission of ultraviolet light to infrared light so as to determine the percentage of organic matter.
5. A method as claimed in claim 2, 3 or 4, characterised in that the light source emitting both ultraviolet and infrared light being a halogen or xenon lamp.

6. A method as claimed in any of the preceding claims, characterised by using a pulsed light radiation.

1/3

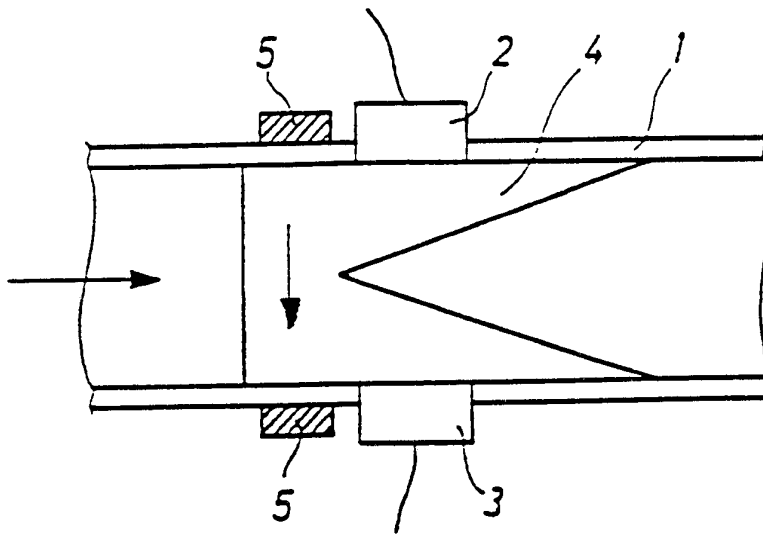

Fig. 1

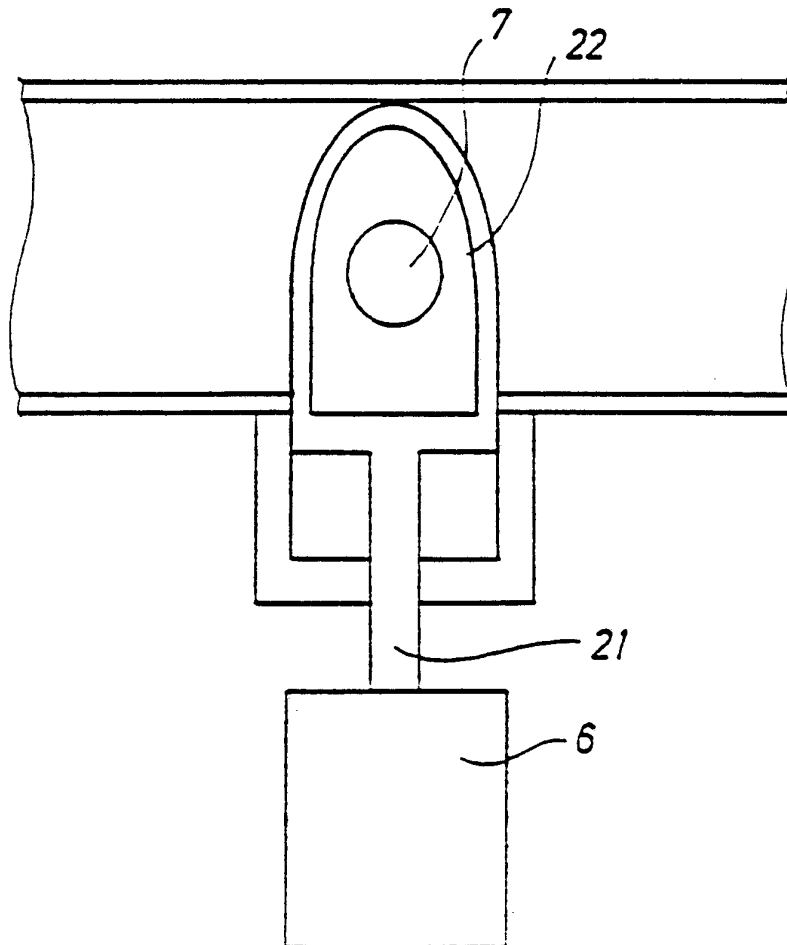

Fig. 2

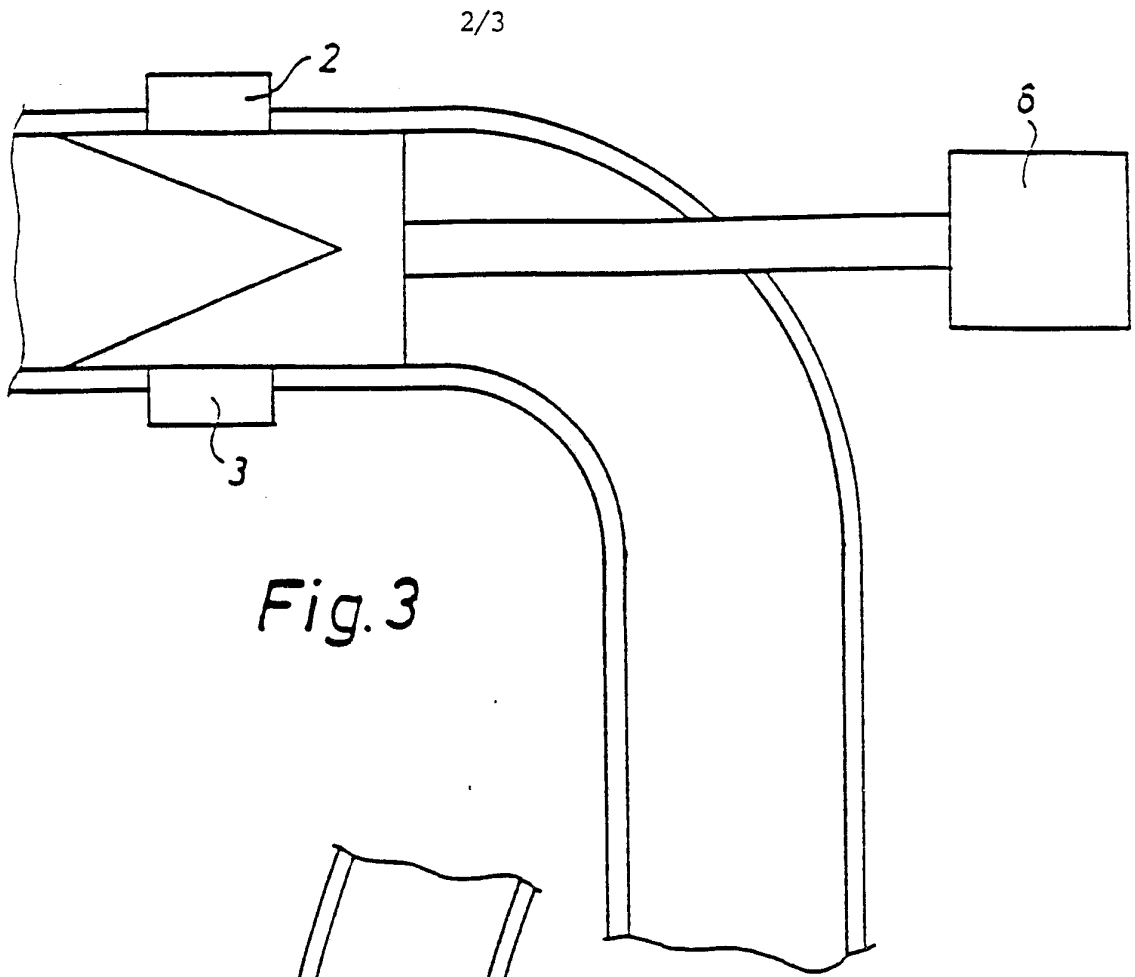

Fig. 3

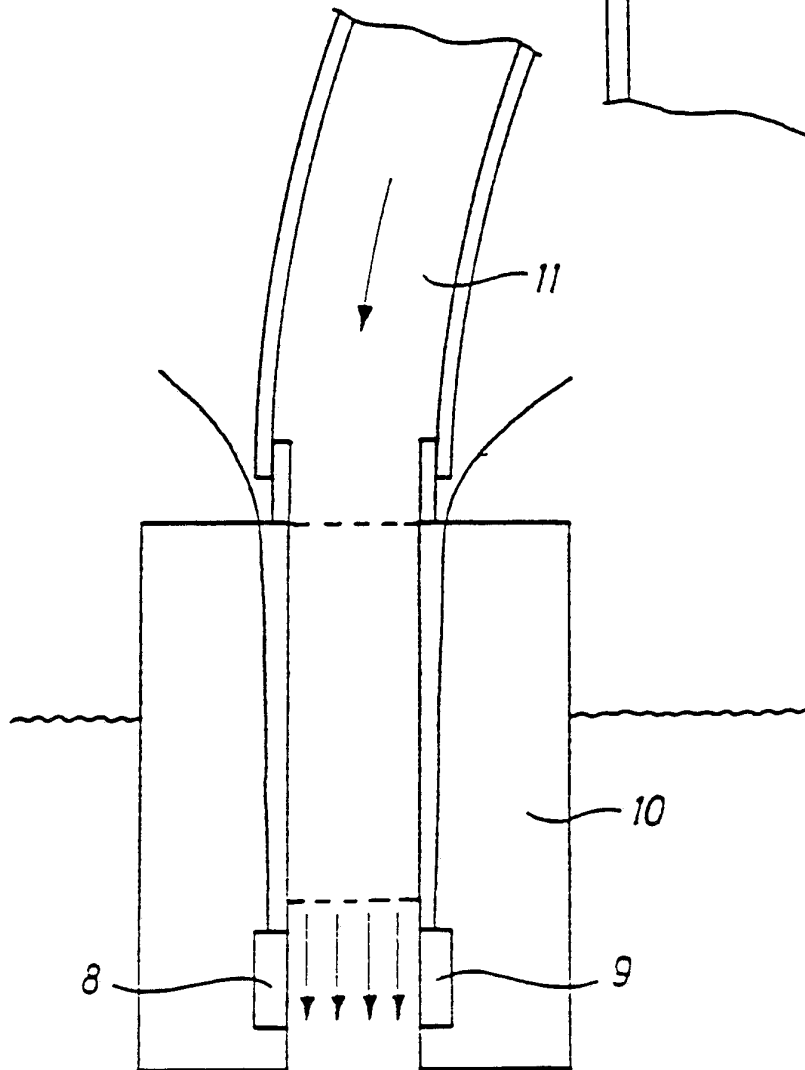

Fig. 4

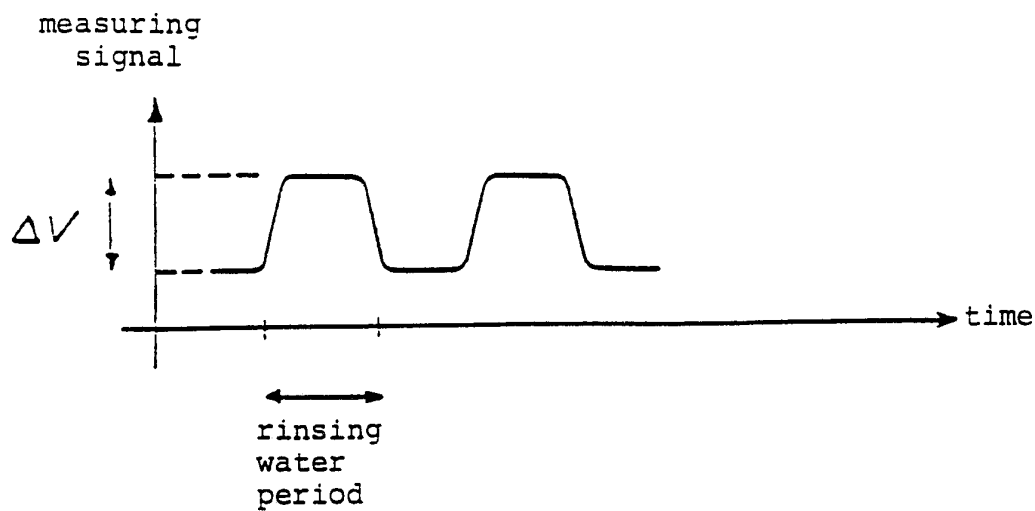

Fig. 5

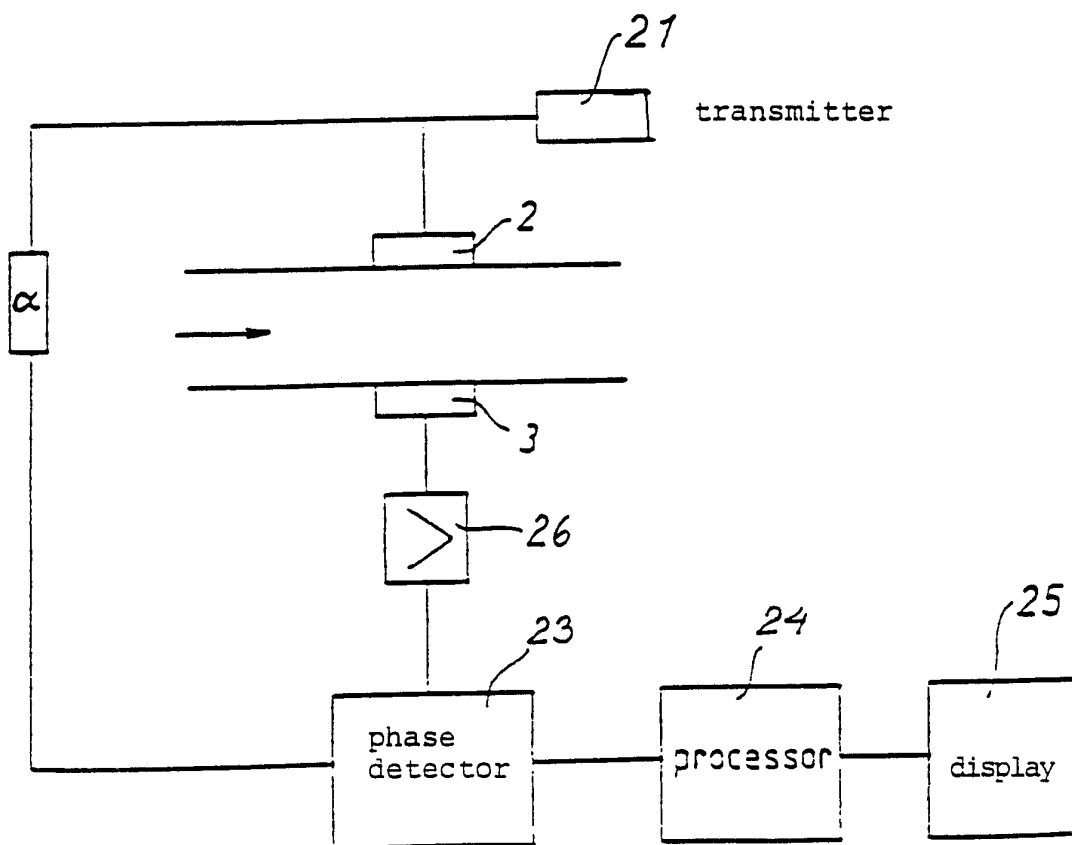
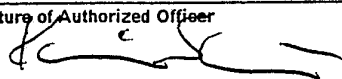

Fig. 6

# INTERNATIONAL SEARCH REPORT

International Application No PCT/DK 91/00053

|   |   |                                     |  |   |
|---|---|-------------------------------------|--|---|
| <b>I. CLASSIFICATION OF SUBJECT MATTER</b> (if several classification symbols apply, indicate all) <sup>6</sup>   |   |                                     |  |   |
| According to International Patent Classification (IPC) or to both National Classification and IPC   |   |                                     |  |   |
| IPC5: G 01 N 21/85, 15/06   |   |                                     |  |   |
| <b>II. FIELDS SEARCHED</b>  |   |                                     |  |   |
| Minimum Documentation Searched <sup>7</sup>   |   |                                     |  |   |
| Classification System   | Classification Symbols  |                                     |  |   |
| IPC5  | G 01 N  |                                     |  |   |
| Documentation Searched other than Minimum Documentation<br>to the Extent that such Documents are Included in Fields Searched <sup>8</sup>   |   |                                     |  |   |
| SE,DK,FI,NO classes as above  |   |                                     |  |   |
| <b>III. DOCUMENTS CONSIDERED TO BE RELEVANT<sup>9</sup></b>   |   |                                     |  |   |
| Category *  | Citation of Document, <sup>11</sup> with indication, where appropriate, of the relevant passages <sup>12</sup>  | Relevant to Claim No. <sup>13</sup> |  |   |
| X   | US, A, 4201477 (W. G. PALMER ET AL)<br>6 May 1980, see column 2, line 13 -<br>line 47; column 3, line 3 - line 9;<br>abstract; figures 1,2  | 1-5,8                               |  |   |
| A   | --  | 6,7                                 |  |   |
| X   | EP, A1, 0039088 (FUJI ELECTRIC CO. LTD)<br>4 November 1981, see page 2, line 1 -<br>line 10; page 2, line 30 - page 3,<br>line 14; abstract; figure 1;<br>claim 1   | 1,3-8                               |  |   |
| X   | US, A, 4299495 (A. SAWAKATA ET AL)<br>10 November 1981, see column 2,<br>line 64 - column 3, line 22;<br>abstract; figure 2;<br>claim 1   | 1-5,8                               |  |   |
| A   | --  | 6,7                                 |  |   |
| <table style="width: 100%; border: none;"> <tr> <td style="width: 50%; border: none; vertical-align: top;"> <p>* Special categories of cited documents: <sup>10</sup></p> <p>"A" document defining the general state of the art which is not considered to be of particular relevance</p> <p>"E" earlier document but published on or after the international filing date</p> <p>"L" document which may throw doubts on priority claim(s) or which is cited to establish the publication date of another citation or other special reason (as specified)</p> <p>"O" document referring to an oral disclosure, use, exhibition or other means</p> <p>"P" document published prior to the international filing date but later than the priority date claimed</p> </td> <td style="width: 50%; border: none; vertical-align: top;"> <p>"T" later document published after the international filing date or priority date and not in conflict with the application but cited to understand the principle or theory underlying the invention</p> <p>"X" document of particular relevance, the claimed invention cannot be considered novel or cannot be considered to involve an inventive step</p> <p>"Y" document of particular relevance, the claimed invention cannot be considered to involve an inventive step when the document is combined with one or more other such documents, such combination being obvious to a person skilled in the art.</p> <p>"&amp;" document member of the same patent family</p> </td> </tr> </table> |   |                                     | <p>* Special categories of cited documents: <sup>10</sup></p> <p>"A" document defining the general state of the art which is not considered to be of particular relevance</p> <p>"E" earlier document but published on or after the international filing date</p> <p>"L" document which may throw doubts on priority claim(s) or which is cited to establish the publication date of another citation or other special reason (as specified)</p> <p>"O" document referring to an oral disclosure, use, exhibition or other means</p> <p>"P" document published prior to the international filing date but later than the priority date claimed</p> | <p>"T" later document published after the international filing date or priority date and not in conflict with the application but cited to understand the principle or theory underlying the invention</p> <p>"X" document of particular relevance, the claimed invention cannot be considered novel or cannot be considered to involve an inventive step</p> <p>"Y" document of particular relevance, the claimed invention cannot be considered to involve an inventive step when the document is combined with one or more other such documents, such combination being obvious to a person skilled in the art.</p> <p>"&amp;" document member of the same patent family</p> |
| <p>* Special categories of cited documents: <sup>10</sup></p> <p>"A" document defining the general state of the art which is not considered to be of particular relevance</p> <p>"E" earlier document but published on or after the international filing date</p> <p>"L" document which may throw doubts on priority claim(s) or which is cited to establish the publication date of another citation or other special reason (as specified)</p> <p>"O" document referring to an oral disclosure, use, exhibition or other means</p> <p>"P" document published prior to the international filing date but later than the priority date claimed</p>  | <p>"T" later document published after the international filing date or priority date and not in conflict with the application but cited to understand the principle or theory underlying the invention</p> <p>"X" document of particular relevance, the claimed invention cannot be considered novel or cannot be considered to involve an inventive step</p> <p>"Y" document of particular relevance, the claimed invention cannot be considered to involve an inventive step when the document is combined with one or more other such documents, such combination being obvious to a person skilled in the art.</p> <p>"&amp;" document member of the same patent family</p> |                                     |  |   |
| <b>IV. CERTIFICATION</b>  |   |                                     |  |   |
| Date of the Actual Completion of the International Search   | Date of Mailing of this International Search Report   |                                     |  |   |
| 24th May 1991   | 1991-05-05  |                                     |  |   |
| International Searching Authority   | Signature of Authorized Officer   |                                     |  |   |
| <b>SWEDISH PATENT OFFICE</b>  | <br><b>KARIN SÄFSTEN</b>  |                                     |  |   |

| III. DOCUMENTS CONSIDERED TO BE RELEVANT (CONTINUED FROM THE SECOND SHEET) |  |                      |
|--|--|----------------------|
| Category *   | Citation of Document, with indication, where appropriate, of the relevant passages   | Relevant to Claim No |
| X  | WO, A1, 8903524 (ELECTRONIC INSTRUMENTATION AND TECHNOLOGY, INC.) 20 April 1989,<br>see page 3, line 22 - page 4, line 18;<br>abstract; figure 1<br>-- | 1,3-5,8              |
| X  | US, A, 4040743 (H. F. VILLAUME) 9 August 1977,<br>see column 2, line 43 - line 55;<br>column 3, line 1 - line 9; abstract;<br>figures 2,3              | 1,3-5,8              |
| A  | --<br>-----  | 2,6                  |

**ANNEX TO THE INTERNATIONAL SEARCH REPORT  
ON INTERNATIONAL PATENT APPLICATION NO. PCT/DK 91/00053**

This annex lists the patent family members relating to the patent documents cited in the above-mentioned international search report. The members are as contained in the Swedish Patent Office EDP file on **91-04-30**. The Swedish Patent Office is in no way liable for these particulars which are merely given for the purpose of information.

| Patent document<br>cited in search report | Publication<br>date | Patent family<br>member(s) | Publication<br>date |
|---|---------------------|----------------------------|---------------------|
| US-A- 4201477                             | 80-05-06            | CA-A- 1106204              | 81-08-04            |
| EP-A1- 0039088                            | 81-11-04            | JP-C- 1355714              | 86-12-24            |
|   |                     | JP-A- 56153242             | 81-11-27            |
|   |                     | JP-B- 61025304             | 86-06-14            |
| US-A- 4299495                             | 81-11-10            | JP-C- 1248953              | 85-01-25            |
|   |                     | JP-A- 55152444             | 80-11-27            |
|   |                     | JP-B- 59023378             | 84-06-01            |
| WO-A1- 8903524                            | 89-04-20            | EP-A- 0335915              | 89-10-11            |
|   |                     | JP-T- 2501677              | 90-06-07            |
|   |                     | US-A- 4938602              | 90-07-03            |
| US-A- 4040743                             | 77-08-09            | AU-B- 503383               | 79-08-30            |
|   |                     | AU-D- 1636976              | 78-02-02            |
|   |                     | CA-A- 1058418              | 79-07-17            |