



(11) **EP 0 969 112 B1**

(12) **EUROPEAN PATENT SPECIFICATION**

- (45) Date of publication and mention of the grant of the patent: **17.08.2011 Bulletin 2011/33**
- (51) Int Cl.: **C22C 38/00<sup>(2006.01)</sup> C22C 38/50<sup>(2006.01)</sup>**  
**C21D 8/02<sup>(2006.01)</sup> C21D 9/46<sup>(2006.01)</sup>**
- (21) Application number: **98907247.5**
- (86) International application number: **PCT/JP1998/001101**
- (22) Date of filing: **16.03.1998**
- (87) International publication number: **WO 1998/041664 (24.09.1998 Gazette 1998/38)**

(54) **A METHOD OF PRODUCING DUAL-PHASE HIGH-STRENGTH STEEL SHEETS HAVING HIGH IMPACT ENERGY ABSORPTION PROPERTIES**

VERFAHREN ZUR HERSTELLUNG VON HOCHFESTEN ZWEIPHASENSTAHLBLECHEN MIT ERHÖHTEN EIGENSCHAFTEN ZUR ABSORPTION VON AUFPRALLENERGIE

PROCEDE DE PREPARATION DES TOLES D'ACIER BIPHASEES A HAUTE RESISTANCE MECANIQUE ET A HAUTE CAPACITE D'ABSORPTION D'ENERGIE DE CHOCK

- (84) Designated Contracting States:  
**DE FR GB NL**
- (30) Priority: **17.03.1997 JP 8243497**  
**15.07.1997 JP 19029797**  
**15.07.1997 JP 19029997**  
**06.08.1997 JP 22300897**  
**24.09.1997 JP 25893897**
- (43) Date of publication of application:  
**05.01.2000 Bulletin 2000/01**
- (60) Divisional application:  
**10181225.3 / 2 314 729**
- (73) Proprietor: **Nippon Steel Corporation**  
**Tokyo 100-8071 (JP)**
- (72) Inventors:
  - **UENISHI, Akihiro**  
c/o Nippon Steel Corporation  
Futtsu City,  
Chiba 293-0011 (JP)
  - **TAKAHASHI, Manabu**  
c/o Nippon Steel Corporation  
Futtsu City,  
Chiba 293-0011 (JP)
  - **KURIYAMA, Yukihisa**  
c/o Nippon Steel Corporation  
Futtsu City,  
Chiba 293-0011 (JP)
- (74) Representative: **Vossius & Partner**  
**Siebertstrasse 4**  
**81675 München (DE)**
- (56) References cited:  
**EP-A- 0 719 868 JP-A- 7 090 482**  
**JP-A- 8 003 677 JP-A- 8 176 723**  
**JP-A- 8 176 738**
- **PATENT ABSTRACTS OF JAPAN vol. 1995, no. 07, 31 August 1995 (1995-08-31) & JP 07 090482 A (KAWASAKI STEEL CORP), 4 April 1995 (1995-04-04)**

Note: Within nine months of the publication of the mention of the grant of the European patent in the European Patent Bulletin, any person may give notice to the European Patent Office of opposition to that patent, in accordance with the Implementing Regulations. Notice of opposition shall not be deemed to have been filed until the opposition fee has been paid. (Art. 99(1) European Patent Convention).

**EP 0 969 112 B1**

- PATENT ABSTRACTS OF JAPAN vol. 1997, no. 04, 30 April 1997 (1997-04-30) & JP 08 325671 A (NIPPON STEEL CORP), 10 December 1996 (1996-12-10)

## Description

**[0001]** The present invention relates to a method of producing dual-phase type high-strength steel sheets, for automobiles use, which have excellent dynamic deformation properties and exhibit excellent impact absorption properties, and are intended to be used as structural members and reinforcing materials primarily for automobiles them.

**[0002]** The applications of high-strength steels have been increasing for the purpose of achieving lighter weight vehicle bodies in consideration of fuel consumption restrictions on automobiles and even more applications for high-strength steel are expected as domestic and foreign restrictions, relating to estimated impact absorption properties in automobile accidents, become rapidly more broad and strict. For example, for frontal collisions of passenger cars, the use of materials with high impact absorption properties for members known as "front side members" can allow impact energy to be absorbed through collapse of the member, thus lessening the impact experienced by passengers.

**[0003]** However, conventional high-strength steels have been developed with a main view toward improving press formability, and doubts exist as to their application in terms of impact absorption properties. Prior art techniques relating to automobile steel with excellent impact absorption properties and methods of producing it have been developed which result in increased yield strength of steel sheets under high deformation speeds as an indicator of impact absorption properties, as disclosed in JP-A-7-18372, but because the members undergo deformation during the shaping process or during collision deformation, it is necessary to include a work-hardening aspect to the yield strength as an indicator of impact resistance, and this is inadequate in terms of anti-collision safety in the prior art described above.

**[0004]** In addition, since the strain rate undergone by each location upon automobile collision reaches about  $10^3$  ( $s^{-1}$ ), consideration of the impact absorption properties of the materials requires an understanding of the dynamic deformation properties in such a high strain rate range. Also, high-strength steel sheets with excellent dynamic deformation properties are understood to be important for achieving both lighter weight and improved impact absorption properties for automobiles, and recent reports have highlighted this fact. For example, the present inventors have reported on the high strain rate properties and impact energy absorption properties of high-strength thin steel sheets in CAMP-ISIJ Vol.9 (1966), pp.1112-1115, wherein they explain that the dynamic strength at a high strain rate of  $10^3$  ( $s^{-1}$ ) increases dramatically compared to the static strength at a low strain rate speed of  $10^{-3}$  ( $s^{-1}$ ), that absorption energy during crashes is increased by greater steel material strengths, that the strain rate dependency of materials depends on the structure of the steel, and that TRIP type steel (Transformation induced plasticity type steel) and dual-phase (hereunder, "DP") type steel exhibit both excellent press formability and high impact absorption properties. Also, the present inventors have already filed Japanese Patent Applications No.8-98000JP-A-2287050 and No.8-109224JP-A-10291016 relating to such a DP-type steel, among which there are proposed high-strength steel sheets with higher dynamic strength than static strength, which are suitable for achieving both lighter weights and improved impact absorption properties for automobiles, and a process for their production.

**[0005]** As mentioned above, although the dynamic deformation properties of high-strength steel sheets are understood at the high strain rates of automobile collisions, it is still unclear what properties should be maximized for automobile members with impact energy absorption properties, and on what criteria the selection of materials should be based. In addition, the automobile members are produced by press forming of steel sheets, and collision impacts are applied to these press formed members. However, high-strength steel sheets with excellent dynamic deformation properties as actual members, based on an understanding of the impact energy absorption properties after such press forming, are still unknown.

**[0006]** For press forming of members for collision safety, a combination of excellent shape fixability, excellent stretchability (tensile strength x total elongation  $\geq 18,000$ ) and excellent flangeability (hole expansion ratio  $\leq 1.2$ ) is desirable, but at the current time no material has provided both excellent impact absorption properties and excellent press formability.

**[0007]** JP-A-07-90482 discloses a cold-rolled thin steel sheet excellent in impact resistance and its production, in which a steel sheet is hot rolled preferably with a finishing hot rolling temperature of  $850^{\circ}\text{C}$  or higher, then the hot-rolled steel sheet is coiled at a temperature of  $650^{\circ}\text{C}$  or higher, and the hot-rolled steel sheet is cold-rolled, annealed at a temperature in the temperature range of  $780$  to  $900^{\circ}\text{C}$ , cooled to  $500^{\circ}\text{C}$  with a cooling rate of  $15$  to  $50^{\circ}\text{C}/\text{sec}$  and further cooled to  $300^{\circ}\text{C}$  with a cooling rate of  $5$  to  $35^{\circ}\text{C}/\text{sec}$ .

**[0008]** EP-A-0 719 868 discloses a steel sheet for automobiles having excellent impact resistance and method of manufacturing the steel sheet, in which a hot-rolled steel sheet is produced by the steps: hot rolling with a finishing temperature of  $780$  to  $850^{\circ}\text{C}$ , starting to cool the hot-rolled steel sheet within  $0.5$  seconds with a cooling rate of  $30^{\circ}\text{C}/\text{sec}$  or more to a temperature range of  $750$  to  $650^{\circ}\text{C}$ , subsequently holding the hot-rolled steel sheet in the temperature range of  $750$  to  $600^{\circ}\text{C}$  for  $4$  to  $60$  seconds, further cooling the hot-rolled steel sheet with a cooling rate of  $30^{\circ}\text{C}/\text{sec}$  or more and coiling in the temperature range of  $500$  to  $100^{\circ}\text{C}$ , and a cold-rolled steel sheet is produced by the steps: annealing a hot-rolled and cold-rolled steel sheet in the temperature range of  $780$  to  $950^{\circ}\text{C}$ , cooling the annealed steel sheet to  $400^{\circ}\text{C}$  at a cooling rate of  $15$  to  $60^{\circ}\text{C}/\text{sec}$  and further cooling the steel sheet to  $150^{\circ}\text{C}$  with a cooling rate of  $3$  to  $15^{\circ}\text{C}/\text{sec}$ .

**[0009]** The present invention has been proposed as a means of overcoming the problems described above, and

provides a method of producing dual-phase type high-strength steel sheets for automobiles use, which have excellent impact absorption properties and excellent dynamic deformation properties.

**[0010]** The invention further provides a method of producing dual-phase type high-strength steel sheets, for automobiles, with excellent dynamic deformation properties, which are high-strength steel sheets used for automotive parts, such as front side members, and which are selected based on exact properties and standards for impact energy absorption during collisions and can reliably provide guaranteed safety.

**[0011]** The invention still further provides a method of producing dual-phase type high-strength steel sheets for automobiles with excellent dynamic deformation properties, which exhibit all the properties suitable for press forming of members, including excellent shape fixability, excellent stretchability and excellent flangeability. The object above can be achieved by the features specified in the claims.

**[0012]** The invention is described in detail in conjunction with the drawings, in which:

Fig. 1 is a graph showing the relationship between the absorption energy ( $E_{ab}$ ) of a shaped member during collision and the material strength ( $S$ ), according to the invention,

Fig. 2 is a perspective view of a shaped member for measurement of impact absorption energy for Fig. 1,

Fig. 3 is a graph showing the relationship between the work hardening coefficient and dynamic energy absorption for a steel sheet,

Fig. 4 is a graph showing the relationship between the yield strength x work hardening coefficient and the dynamic energy absorption for a steel sheet,

Fig. 5 is a general view of a "hat model" used in the impact crush test method relating to Figs. 3 and 4,

Fig. 6 is a cross-sectional view of the shape of the test piece of Fig. 5,

Fig. 7 is a schematic view of the impact crush test method relating to Figs. 3-6,

Fig. 8 is a graph showing the relationship between  $TS$  and the difference between the average value  $\sigma_{dyn}$  of the deformation stress in the range of 3~10% of equivalent strain when deformed in a strain rate range of  $5 \times 10^2 - 5 \times 10^3$  (1/S) and  $TS$ , as an index of the impact energy absorption property upon collision, according to the invention,

Fig. 9 is a graph showing the change in the static/dynamic ratio with tempered rolling for an example of the invention and a comparative example,

Fig. 10 is a graph showing the relationship between  $\Delta T$  and the metallurgy parameter  $A$  for a hot-rolling step according to the invention,

Fig. 11 is a graph showing the relationship between the coiling temperature and the metallurgy parameter  $A$  for a hot-rolling step according to the invention, and

Fig. 12 is a graph showing the annealing cycle for continuous annealing according to the invention.

**[0013]** Impact absorbing members such as front side members of automobiles are produced by bending and press forming of steel sheets. Because impacts during automobile collisions are absorbed by such members which have undergone press forming, they must have high impact absorption properties even after having undergone the pre-deformation corresponding to the press forming. At the current time, however, no attempt has been made to obtain high-strength steel sheets with excellent impact absorption properties as actual members, with consideration of both the increase in the deformation stress by press forming and the increase in deformation stress due to a higher strain rate, as was mentioned above.

**[0014]** As a result of much experimentation and research with the aim of achieving this purpose, the present inventors have found that steel sheets with a dual-phase (DP) structure are ideal as high-strength steel sheets with excellent impact absorption properties for actual members which are press formed as described above. It was demonstrated that such steel sheets with a dual-phase microstructure, which is a composite microstructure wherein the dominating phase is a ferrite phase responsible for the increase in deformation resistance by an increased strain rate, and the second phase includes a hard martensite phase, have excellent dynamic deformation properties. That is, it was found that high dynamic deformation properties are exhibited when the microstructure of the final steel sheets is a composite structure wherein the dominating phase is ferrite and another low temperature product phase includes a hard martensite phase at a volume fraction of 3~50% after deformation at 5% equivalent strain of the steel sheet.

**[0015]** Concerning the volume fraction of 3~50% for the hard martensite phase, since high-strength steel sheets and even steel sheets with high dynamic deformation properties cannot be obtained if the martensite phase is less than 3%, the volume fraction of the martensite phase must be at least 3%. Also, if the martensite phase exceeds 50%, this results in a smaller volume fraction of the ferrite phase responsible for greater deformation resistance due to increased deformation speed, making it impossible to obtain steel sheets with excellent dynamic deformation properties compared to static deformation strength while also hindering press formability, and therefore it was found that the volume fraction of the martensite phase must be 3~50%.

**[0016]** The present inventors then pursued experimentation and research based on these findings and, as a result, found that although the degree of pre-deformation corresponding to press forming of impact absorbing members such

as front side members sometimes reaches a maximum of over 20%, depending on the location, the majority are locations with 0%~10% of equivalent strain, and that by understanding the effect of pre-deformation in this range, it is possible to estimate the behavior of the member as a whole after pre-deformation. Consequently, according to the invention, a deformation of from 0% to 10% of equivalent strain was selected as the amount of pre-deformation applied to members during press forming.

**[0017]** Fig. 1 is a graph showing the relationship between the absorption energy ( $E_{ab}$ ) of a press formed member during collision and the material strength ( $S$ ), for the different steel types shown in Table 5, according to an example to be described later. The material strength  $S$  is the tensile strength (TS) according to the common tensile test. The member absorption energy ( $E_{ab}$ ) is the absorption energy in the lengthwise direction (direction of the arrow) along a press formed member such as shown in Fig. 2, upon collision with a 400 kg mass weight at a speed of 15 m/sec, to a crushing degree of 100 mm. The shaped member in Fig. 2 consists of a 2.0 mm-thick steel sheet formed into a hat-shaped section 1 with a steel sheet 2 of the same thickness and the same type of steel, joined together by spot welding, the hat-shaped section 1 having a corner radius of 2 mm, and with spot welding points indicated by 3.

**[0018]** From Fig. 1 it is seen that the member absorption energy ( $E_{ab}$ ) tends to increase with the strength of materials under normal tensile testing, though with considerable variation. Here, the materials in Fig. 1 were subjected to pre-deformation of more than 0% and less than or equal to 10% of equivalent strain, and then the static deformation strength  $\sigma_s$  when deformed in a strain rate range of  $5 \times 10^{-4} - 5 \times 10^{-3} (s^{-1})$  and the dynamic deformation strength  $\sigma_d$  when deformed in a strain rate range of  $5 \times 10^2 - 5 \times 10^3 (s^{-1})$  after the pre-deformation, were measured. As a result, a classification was possible based on  $(\sigma_d - \sigma_s)$ . The symbols plotted in Fig. 1 were as follows:

- :  $(\sigma_d - \sigma_s) < 60$  MPa with any pre-deformation of more than 0% and less than or equal to 10%;
- :  $60 \text{ MPa} \leq (\sigma_d - \sigma_s)$  with any pre-deformation in the above range, and  $60 \text{ MPa} \leq (\sigma_d - \sigma_s) < 80$  MPa with pre-deformation of 5%;
- :  $60 \text{ MPa} \leq (\sigma_d - \sigma_s)$  with any pre-deformation in the above range, and  $80 \text{ MPa} \leq (\sigma_d - \sigma_s) < 100$  MPa with pre-deformation of 5%;
- ▲:  $60 \text{ MPa} \leq (\sigma_d - \sigma_s)$  with any pre-deformation in the above range, and  $100 \text{ MPa} \leq (\sigma_d - \sigma_s)$  with pre-deformation of 5%.

**[0019]** Also, when  $60 \text{ MPa} \leq (\sigma_d - \sigma_s)$  with any pre-deformation in the range of more than 0% and less than or equal to 10% of equivalent strain, the values for member absorption energy ( $E_{ab}$ ) during collision was equal to or greater than the values predicted from the material strength  $S$ , thus indicating steel sheets with excellent dynamic deformation properties as impact absorbing members for collision. These predicted values are those shown in the curve in Fig. 1, represented by  $E_{ab} = 0.062S^{0.8}$ . Consequently,  $(\sigma_d - \sigma_s)$  must be at least 60 MPa.

**[0020]** For improved impact absorption properties, it is basically important to increase the work hardening coefficient, specifically to at least 0.13, and preferably at least 0.16; by controlling the yield strength and the work hardening coefficient to specified ranges it is possible to achieve excellent impact absorption properties, and for improved press formability it is effective to design the volume percentage and particle size of the martensite to within a specified range.

**[0021]** Fig. 3 shows the relationship between the work hardening coefficient of a steel sheet and the dynamic energy absorption which indicates the member impact absorption properties, for a class of materials with the same yield strength. Here it is shown that increased work hardening coefficients of the steel sheets result in improved member impact absorption properties (dynamic energy absorption), and that the work hardening coefficient of a steel sheet can properly indicate the member impact absorption properties so long as the yield strength class is the same. Also, when the yield strengths differ, as shown in Fig. 4, the yield strength  $\times$  work hardening coefficient can be an indicator of the member impact absorption properties. While the work hardening coefficient was expressed in terms of an  $n$  value of 5%~10% strain in consideration of the strain undergone by members during press forming, from the viewpoint of improving the dynamic energy absorption, work hardening coefficients of under 5% strain or work hardening coefficients of even more than 10% strain may be preferred.

**[0022]** The dynamic energy absorptions for members shown in Fig. 3 and Fig. 4 were determined in the following manner. Specifically, the steel sheet was shaped into the member shape shown in Fig. 6 (corner  $R = 5$  mm) and spot welded at 35 mm pitch using an electrode with a tip radius of 5.5 mm at a current of 0.9 times the expulsion current, and then after baking and painting treatment at  $170^\circ\text{C} \times 20$  minutes, an approximately 150 Kg falling weight was dropped from a height of about 10 m to crush the member in its lengthwise direction, and the displacement work where displacement = 0-150 mm is calculated from the area of the corresponding load displacement diagram to determine the dynamic energy absorption. A schematic illustration of this test method is shown in Fig. 7. In Fig. 5, 4 is a worktop, 5 is a test piece and 6 is a spot welding section.

**[0023]** In Fig. 6, 7 is a hat-shaped test piece and 8 is a spot welding section. In Fig. 7, 9 is a worktop, 10 is a test piece, 11 is a falling weight (150 kg), 12 is a frame, and 13 is a shock absorber. The work hardening coefficient and yield strength of each steel sheet was determined in the following manner. The steel sheet was shaped into a JIS-#5

test piece (gauge length: 50 mm, parallel width: 25 mm), subjected to tensile test at a strain rate of 0.001 (s<sup>-1</sup>) to determine the yield strength and work hardening coefficient (n value at 5%~10% strain). The steel sheet used had a sheet thickness of 1.2 mm and the steel sheet composition contained C at 0.02-0.25 wt%, either or both Mn and Cr at a total of 0.15~3.5 wt% and one or more of Si, Al and P at a total of 0.02-4.0 wt%, with the remainder Fe as the main component.

5 **[0024]** Fig. 8 is a graph showing the relationship between the average value  $\sigma_{dyn}$  of the deformation stress in the range of 3~10% of equivalent strain when deformed in a strain rate range of  $5 \times 10^2 - 5 \times 10^3$  (s<sup>-1</sup>) and the static material strength (TS), as an index of the impact energy absorption property upon collision, according to the invention, where the static material strength (TS) is the tensile strength (TS: MPa) in the static tensile test as measured in a strain rate range of  $5 \times 10^{-4} - 5 \times 10^{-3}$  (s<sup>-1</sup>).

10 **[0025]** As mentioned above, impact absorbing members such as front side members have a hat-shaped cross-sectional shape, and as a result of analysis of deformation of such members upon crushing by high-speed collision, the present inventors have found that despite deformation proceeding up to a high maximum strain of over 40%, at least 70% of the total absorption energy is absorbed in a strain range of 10% or lower in a high-speed stress-strain diagram. Therefore, the dynamic deformation resistance with high-speed deformation at 10% or lower was used as the index of the high-speed collision energy absorption property. In particular, since the amount of strain in the range of 3~10% is most important, the index used for the impact energy absorption property was the average stress:  $\sigma_{dyn}$  in the range of 3~10% of equivalent strain when deformed in a strain rate range of  $5 \times 10^2 - 5 \times 10^3$  (s<sup>-1</sup>) high-speed tensile deformation.

15 **[0026]** The average stress:  $\sigma_{dyn}$  of 3~10% upon high-speed deformation generally increases with increasing static tensile strength {maximum stress (TS: MPa) in a static tensile test measured in a stress rate range of  $5 \times 10^{-4} - 5 \times 10^{-3}$  (s<sup>-1</sup>)} of the steel material prior to pre-deformation or baking treatment. Consequently, increasing the static tensile strength (which is synonymous with the static material strength) of the steel material directly contributes to an improved impact energy absorption property of the member. However, increased strength of the steel results in poorer press formability into members, making it difficult to obtain members with the necessary shapes. Consequently, steels having a high  $\sigma_{dyn}$  with the same tensile strength TS are preferred. It was found that, based on this relationship, steel sheets wherein the average value  $\sigma_{dyn}$  (MPa) of the deformation stress in the range of 3~10% of equivalent strain when deformed in a strain rate range of  $5 \times 10^2 - 5 \times 10^3$  (s<sup>-1</sup>), after pre-deformation of more than 0% and less than or equal to 10% of equivalent strain satisfies the inequality:  $\sigma_{dyn} \geq 0.766 \times TS + 250$  as expressed in terms of the tensile strength (TS: MPa) in the static tensile test as measured in a strain rate range of  $5 \times 10^{-4} - 5 \times 10^{-3}$  (s<sup>-1</sup>) prior to pre-deformation, have higher impact energy absorption properties as actual members compared to other steels, and that the impact energy absorption property is improved without increasing the overall weight of the member, making it possible to provide high-strength steel sheets with high dynamic deformation resistance.

25 **[0027]** Also, although the details are still unclear, it has been discovered that steel sheets with excellent dynamic deformation properties can be obtained when, as shown in Fig. 9,  $YS(0)/TS'(5)$  is no greater than 0.7, which amount is dependent on the initial microstructure, the amount of solid solution elements in the low temperature product phase other than the martensite phase and the main ferrite phase, and the deposited state of carbides, nitrides and carbonitrides. Here,  $YS(0)$  is the yield strength, and  $TS'(5)$  is the tensile strength ( $TS'$ ) in the static tensile test with pre-deformation at 5% of equivalent strain or after further bake hardening treatment (BH treatment). It was also demonstrated that steel sheets with even more excellent dynamic deformation properties can be obtained when the yield strength:  $YS(0) \times$  work hardening coefficient is at least 70.

30 **[0028]** Furthermore, it is known that dynamic deformation strength is usually expressed in the form of the power of the static tensile strength, and as the static tensile strength increases, the difference between the dynamic deformation strength and the static deformation strength decreases. However, a small difference between the dynamic deformation strength and the static deformation strength will mean that no greater improvement in the impact absorption properties can be expected. From this standpoint, it is preferred for the value of  $(\sigma_d - \sigma_s)$  to be in a range which satisfies the following inequality,  $(\sigma_d - \sigma_s) \geq 4.1 \times \sigma_s^{0.8} - \sigma_s$ .

35 **[0029]** The microstructure of a steel sheet according to the invention will now be described in detail. As already mentioned, the martensite is at a volume fraction of 3-50%, and preferably 3~30%. The average grain size of the martensite is preferably no greater than 5  $\mu\text{m}$ , and the average grain size of the ferrite is preferably no greater than 10  $\mu\text{m}$ . That is, the martensite is hard, and contributes to a decrease in the yield ratio and an improvement in the work hardening coefficient, by producing a mobile dislocations primarily in adjacent ferrite grains; however, by satisfying the restrictions mentioned above it is possible to disperse fine martensite in the steel, so that the improvement in the properties spreads throughout the entire steel sheet. In addition, this dispersion of fine martensite in the steel can help to avoid deterioration in the hole expansion ratio and tensile strength  $\times$  total elongation, which is an adverse effect of the hard martensite. Also, because it is possible to reliably achieve work hardening coefficient  $\geq 0.130$ , tensile strength  $\times$  total elongation  $\geq 18,000$  and hole expansion ratio  $\geq 1.2$ , it is thereby possible to improve the impact absorption properties and press formability.

40 **[0030]** With a martensite volume fraction of less than 3%, the yield ratio becomes larger while the press formed member cannot exhibit an excellent work hardening property (work hardening coefficient  $\geq 0.130$ ) after it has undergone

collision deformation, and since the deformation resistance (load) stays at a low level, and the dynamic energy absorption is low preventing improvement in the impact absorption properties. On the other hand, with a martensite volume fraction of greater than 50%, the yield ratio becomes larger while work hardening coefficient is reduced, and deterioration also occurs in the tensile strength  $\times$  total elongation and the hole expansion ratio. From the standpoint of press formability,

the volume fraction of the martensite is preferred to be no greater than 30%.  
**[0031]** Also, the ferrite is present at a volume fraction of preferably at least 50%, and more preferably at least 70%, and its average grain size (mean circle equivalent diameter) is preferably no greater than 10  $\mu\text{m}$ , and more preferably no greater than 5  $\mu\text{m}$ , with the martensite preferably adjacent to the ferrite. This aids the fine dispersion of the martensite in the ferrite matrix, while effectively extending the property-improving effect, beyond simply a local effect, to the entire steel sheet, favorably acting to prevent the adverse effects of the martensite. The structure of the remainder present with the martensite and ferrite may be a mixed structure comprising a combination of one or more from among pearlite, bainite, retained  $\gamma$ , etc., and although primarily bainite is preferred in cases which require hole expansion properties, since retained  $\gamma$  undergoes work-induced transformation into martensite by press forming, experimental results have shown that including retained austenite prior to press forming has an effect even in preferred small amounts (5% or less).

**[0032]** Also, from the standpoint of impact absorption properties and press formability it is preferred for the ratio of the martensite and ferrite particle sizes to be no greater than 0.6, and the ratio of the hardnesses to be at least 1.5.

**[0033]** The restrictions on the values for the chemical components of dual-phase type high-strength steel sheets with excellent dynamic deformation properties according to the invention, and the reasons for those restrictions, will now be explained.

**[0034]** Dual-phase type high-strength steel sheets with excellent dynamic deformation properties which are used according to the invention are steel sheets containing the following chemical compositions, in terms of weight percentage: C at 0.02~0.25%, either or both Mn and Cr at a total of 0.15~3.5%, one or more from among Si, Al and P at a total of 0.02~4.0%, if necessary also one or more from among Ni, Cu and Mo at a total of no more than 3.5%, one or more from among Nb, Ti and V at no more than 0.30%, and either or both Ca and REM at 0.0005~0.01% for Ca and 0.005~0.05% for REM, with the remainder Fe as the primary component. They are also dual-phase type high strength steel sheets with excellent dynamic deformation properties which contain, if necessary, one or more from among B ( $\leq 0.01$ ), S ( $\leq 0.01\%$ ) and N ( $\leq 0.02\%$ ). These chemical components and their contents (percent by weight) will now be discussed.

**[0035]** C: C is the element which most strongly affects the microstructure of the steel sheet, and if its content is too low it will become difficult to obtain martensite with the desired amount and strength. Addition in too great an amount leads to unwanted carbide precipitation, inhibited increase in deformation resistance at higher strain rates and overly high strength, as well as poor press formability and weldability; the content is therefore 0.02-0.25 wt%.

**[0036]** Mn, Cr: Mn and Cr have an effect of stabilizing austenite and guaranteeing sufficient martensite, and are also solid solution hardening elements; they must therefore be added in a minimum amount of 0.15 wt%, but if added in too much the aforementioned effect becomes saturated thus producing adverse effects such as preventing ferrite transformation, and thus they are added in the maximum amount of 3.5 wt%.

**[0037]** Si, Al, P: Si and Al are useful elements for producing martensite, and they promote production of ferrite and suppress precipitation of carbides, thus having the effect of guaranteeing sufficient martensite, as well as a solid solution hardening effect and a deoxidization effect. P can also promote martensite formation and solid solution hardening, similar to Al and Si. From this standpoint, the minimum amount of Si + Al + P added must be at least 0.02 wt%. On the other hand, excessive addition will saturate this effect and result instead in brittleness, and therefore the maximum amount of addition is no more than 4.0 wt%. In particular, when an excellent surface condition is required, Si scales can be avoided by adding Si at no greater than 0.1 wt%, and conversely by adding it at 1.0 wt% or greater Si scales can be produced over the entire surface so that they are not conspicuous. Also, when excellent secondary workability, toughness, spot weldability and recycling properties are required, the P content may be kept at no greater than 0.05%, and preferably no greater than 0.02%.

**[0038]** Ni, Cu, Mo: These elements are added when necessary, and are austenite-stabilizing elements similar to Mn, which increase the hardenability of the steel, and are effective for adjustment of the strength. From the standpoint of weldability and chemical treatment, they can be used when the amounts of C, Si, Al and Mn are restricted, but if the total amount of these elements added exceeds 3.5 wt% the dominant ferrite phase will tend to be hardened, thus inhibiting the increase in deformation resistance by a greater strain rate, as well as raising the cost of the steel sheet; the amount of these elements added is therefore 3.50 wt% or lower.

**[0039]** Nb, Ti, V: These elements are added when necessary, and are effective for strengthening the steel sheet through formation of carbides, nitrides and carbonitrides. However, when added at greater than 0.3 wt% they are deposited in large amounts in the dominant ferrite phase or at the grain boundaries as carbides, nitrides and carbonitrides, becoming a source of the mobile dislocation during high speed deformation, and inhibiting the increase in deformation resistance by greater strain rates. In addition, the deformation resistance of the dominant phase becomes higher than necessary, thus wasting the C and leading to higher costs; the maximum amount to be added is therefore 0.3 wt%.

**[0040]** B: B is an element which is effective for strengthening since it improves the hardenability of the steel by

suppressing production of ferrite, but if it is added at greater than 0.01 wt% its effect will be saturated, and therefore B is added at a maximum of 0.01 wt%.

**[0041]** Ca, REM: Ca is added to at least 0.0005 wt% for improved press formability (especially hole expansion ratio) by shape control (spheroidization) of sulfide-based inclusions, and the maximum amount thereof to be added is 0.01 wt% in consideration of effect saturation and the adverse effect due to increase in the aforementioned inclusions (reduced hole expansion ratio). For the same reasons, REM is added in an amount of from 0.005% to 0.05 wt%.

**[0042]** S: The amount of S is no greater than 0.01 wt%, and preferably no greater than 0.003 wt%, from the standpoint of press formability (especially hole expansion ratio) by sulfide-based inclusions, and reduced spot weldability.

**[0043]** The method of applying the pre-deformation according to the invention will now be explained. The pre-deformation may be press forming for member shaping, or it may be working with a tempering rolling or tension leveler which applied to the steel sheet material prior to its press forming. In this case, either or both a tempering roller and tension leveler may be used. That is, the means used may include a tempering rolling, a tension leveler, or a tempering roller and tension leveler. The steel sheet material may also be subjected to press forming after being worked with a tempering rolling or tension leveler. The amount of pre-deformation applied with the tempering rolling and/or tension leveler, i.e. the degree of plastic deformation (T), will differ depending on the initial dislocation density, and T should be small if the initial density is large. Also, with few solid solution elements the introduced dislocations cannot be fixed, and high dynamic deformation properties cannot be guaranteed. Consequently, it was found that the plastic deformation (T) is determined based on the ratio between the yield strength YS(0) and the tensile strength TS'(5) in the static tensile test with pre-deformation at 5% of equivalent strain or after further bake hardening treatment (BH treatment), or YS(0)/TS'(5). That is, YS(0)/TS'(5) is an indicator of the sum of the initial dislocation density and the dislocation density introduced by 5% deformation, and the amount of the solid solution elements; it may be concluded that a smaller YS(0)/TS'(5) means a higher initial dislocation density and more of the solid solution elements. YS(0)/TS'(5) is therefore no greater than 0.7, and is preferably provided according to the following equation:

$$2.5 \{YS(0)/TS'(5) - 0.5\} + 15 \geq T \geq 2.5 \{YS(0)/TS'(5) - 0.5\} + 0.5$$

wherein the upper limit for T is determined from the standpoint of press formability including impact absorption property and flexibility.

**[0044]** A method of producing a dual-phase type high strength hot rolled steel sheet and a cold rolled steel sheet with excellent dynamic deformation properties according to the invention will now be explained. In this production method, a continuous cast slab is fed directly from casting to a hot rolling step, or is hot rolled upon reheating after momentary cooling. Thin gauge continuous casting and continuous hot rolling techniques (endless hot rolling) may be applied for the hot rolling in addition to normal continuous casting, but in order to avoid a lower ferrite volume fraction and a coarser average grain size of the thin steel sheet microstructure, the bar (cast strip) thickness at the hot rolling approach side (the initial steel bar thickness) is preferred to be at least 25 mm. At less than 25 mm, the mean circle equivalent size of ferrite of the steel sheet is made coarser, while it is also a disadvantage against obtaining the desired martensite. The final pass rolling speed for the hot rolling is preferred to be at least 500 mpm and more preferably at least 600 mpm, in light of the problems described above. At less than 500 mpm, the mean circle equivalent diameter of ferrite of the steel sheet is made coarser, while it is also a disadvantage against obtaining the desired martensite.

**[0045]** The finishing temperature for the hot rolling is from  $Ar_3 - 50^\circ C$  to  $Ar_3 + 120^\circ C$ . At lower than  $Ar_3 - 50^\circ C$ , deformed ferrite is produced, with inferior work hardening property and press formability. At higher than  $Ar_3 + 120^\circ C$ , and the mean circle equivalent size of ferrite of the steel sheet is made coarser, while it is also becomes difficult to obtain the desired martensite.

**[0046]** The average cooling rate for cooling in the run-out table is least  $5^\circ C/sec$ . At less than  $5^\circ C/sec$  it becomes difficult to obtain the desired martensite.

**[0047]** The coiling temperature is no higher than  $350^\circ C$ . At higher than  $350^\circ C$  it becomes difficult to obtain the desired martensite.

**[0048]** According to the invention, it was found particularly that a correlation exists between the finishing temperature in the hot rolling step, the finishing approach temperature and the coiling temperature. That is, as shown in Fig. 10 and Fig. 11, specific conditions exist which are determined primarily between the finishing temperature, finishing approach temperature and the coiling temperature. Specifically, the hot rolling is carried out so that when the finishing temperature for hot rolling is in the range of  $Ar_3 - 50^\circ C$  to  $Ar_3 + 120^\circ C$ , the metallurgy parameter A satisfies inequalities (1) and (2). The above-mentioned metallurgy parameter A may be expressed by the following equation.

$$A = \varepsilon^* \times \exp\{(75282 - 42745 \times C_{eq})/[1.978 \times (FT + 273)]\}$$

5

where

FT: finishing temperature (°C)

Ceq: carbon equivalents = C + Mn<sub>eq</sub>/6 (%)

10 Mn<sub>eq</sub>: manganese equivalents = Mn + (Ni + Cr + Cu + Mo)/2 (%)

ε\*: final pass strain rate (s<sup>-1</sup>)

$$\varepsilon^* = (v/\sqrt{R \times h_1}) \times (1/\sqrt{r}) \times \ln \{1/(1-r)\}$$

15

h<sub>1</sub>: final pass approach sheet thickness

h<sub>2</sub>: final pass exit sheet thickness

r: (h<sub>1</sub> - h<sub>2</sub>)/h<sub>1</sub>

20

R: roll radius

v: final pass exit speed

25  $\Delta T$ : finishing temperature (finishing final pass exit temperature) - finishing approach temperature (finishing first pass approach temperature)

25

$$Ar_3: 901 - 325 C\% + 33 Si\% - 92 Mn_{eq}$$

30

[0049] Thereafter, it is preferred for the average cooling rate on the run-out table to be at least 5°C/sec, and the coiling to be carried out under conditions such that the relationship between the metallurgy parameter A and the coiling temperature (CT) satisfies inequality (3).

35

$$9 \leq \log A \leq 18 \quad (1)$$

40

$$\Delta T \leq 21 \times \log A - 61 \quad (2)$$

$$CT \leq 6 \times \log A + 242 \quad (3)$$

45

[0050] In inequality (1) above, a log A of less than 9 is unacceptable from the viewpoint of production of retained martensite and refinement of the microstructure, while it will also result in an inferior dynamic deformation resistance σ<sub>dyn</sub> and 5~10% work hardening property. Also, if log A is to be greater than 18, massive equipment will be required to achieve it. With inequality (2), if the condition of inequality (2) is not satisfied it will be impossible to obtain the desired martensite, and the dynamic deformation resistance σ<sub>dyn</sub> and 5~10% work hardening property, etc. will be inferior. The lower limit for ΔT is more flexible with a lower log A as indicated by inequality (2). Furthermore, if the relationship with the coiling temperature in inequality (3) is not satisfied, there will be an adverse effect on ensuring the amount of martensite, while the retained γ will be excessively stable even if retained γ can be obtained, it will be impossible to obtain the desired martensite during deformation, and the dynamic deformation resistance σ<sub>dyn</sub> and 5~10% work hardening property, etc. will be inferior. The limit for the coiling temperature is more flexible with a higher log A.

50

55

[0051] The cold rolled sheet according to the invention is then subjected to the different steps following hot-rolling and coiling and is cold rolled and subjected to annealing. The annealing is ideally continuous annealing through an annealing cycle such as shown in Fig. 12, and during the annealing of the continuous annealing step, it must be kept for at least

10 seconds in the temperature range of  $Ac_1 - Ac_3$ . At less than  $Ac_1$  austenite will not be produced and it will therefore be impossible to obtain martensite thereafter, while at greater than  $Ac_3$  the austenite monophase structure will be coarse, and it will therefore be impossible to obtain the desired average grain size for the martensite. Also, at less than 10 seconds the austenite production will be insufficient, making it impossible to obtain the desired martensite thereafter.

The maximum residence time is preferably no greater than 200 seconds, from the standpoint of avoiding addition to the equipment and coarsening of the microstructure. The cooling after this annealing must be at an average cooling rate of at least  $5^\circ\text{C}/\text{sec}$ . At less than  $5^\circ\text{C}/\text{sec}$  the desired space factor for the martensite cannot be achieved. Although there is no particular upper limit here, it is preferably  $300^\circ\text{C}/\text{sec}$  when considering temperature control during the cooling.

[0052] According to the invention, the cooled steel sheet is heated to a temperature  $T_0$  from  $Ac_1 - Ac_3$  in the continuous annealing cycle shown in Fig. 12, and cooled under cooling conditions provided by a method wherein cooling to a secondary cooling start temperature  $T_q$  in the range of  $550^\circ\text{C} - T_0$  at the primary cooling rate of  $1 - 10^\circ\text{C}/\text{sec}$  is followed by cooling to a secondary cooling end temperature  $T_e$  which is no higher than a temperature  $T_{em}$  which is determined by the chemical compositions of the steel and annealing temperature  $T_0$ , at a secondary cooling rate of  $10 - 200^\circ\text{C}/\text{sec}$ . This is a method whereby the cooling end temperature  $T_e$  in the continuous annealing cycle shown in Fig. 12 is represented as a function of the chemical compositions and annealing temperature, and is kept under a given critical value. After cooling to  $T_e$ , the temperature is preferably held in a range of  $T_e - 50^\circ\text{C}$  to  $400^\circ\text{C}$  for up to 20 minutes prior to cooling to room temperature.

[0053] Here,  $T_{em}$  is the martensite transformation start temperature for the retained austenite at the quenching start point  $T_q$ . That is,  $T_{em}$  is defined by  $T_{em} = T_1 -$

[0054]  $T_2$ , or the difference between the value excluding the effect of the C concentration in the austenite ( $T_1$ ) and the value indicating the effect of the C concentration ( $T_2$ ). Here,  $T_1$  is the temperature calculated from the solid solution element concentration excluding C, and  $T_2$  is the temperature calculated from the C concentration in the retained austenite at  $Ac_1$  and  $Ac_3$  determined by the chemical compositions of the steel and  $T_q$  determined by the annealing temperature  $T_0$ .  $C_{eq}$  represents the carbon equivalents in the retained austenite at the annealing temperature  $T_0$ . Thus,  $T_1$  is expressed as:

$$T_1 = 561 - 33 \times \{Mn\% + (Ni + Cr + Cu + Mo)/2\}$$

and  $T_2$  is expressed in terms of:

$$Ac_1 = 723 - 0.7 \times Mn\% - 16.9 \times Ni\% + 29.1 \times Si\% + 16.9 \times Cr\%,$$

$$Ac_3 = 910 - 203 \times (C\%)^{1/2} - 15.2 \times Ni\% + 44.7 \times Si\% + 104 \times V\% + 31.5 \times Mo\% - 30 \times Mn\% - 11 \times Cr\% - 20 \times Cu\% + 70 \times P\% + 40 \times Al\% + 400 \times Ti\%,$$

and the annealing temperature  $T_0$ , and when

$$C_{eq}^* = (Ac_3 - Ac_1) \times C / (T_0 - Ac_1) + (Mn + Si/4 + Ni/7 + Cr + Cu + 1.5 Mo) / 6$$

is greater than 0.6,  $T_2 = 474 \times (Ac_3 - Ac_1) \times C / (T_0 - Ac_1)$ ,

and when it is 0.6 or less,  $T_2 = 474 \times (Ac_3 - Ac_1) \times C / \{3 \times (Ac_3 - Ac_1) \times C + [(Mn + Si/4 + Ni/7 + Cr + Cu + 1.5 Mo) / 2 - 0.85] \times (T_0 - Ac_1)\}$ .

[0055] In other words, when  $T_e$  is equal to or greater than  $T_{em}$ , the desired martensite cannot be obtained. Also, if  $T_{0a}$  is  $400^\circ\text{C}$  or higher, the martensite obtained by cooling is tempered, making it impossible to achieve satisfactory dynamic properties and press formability. On the other hand, if  $T_{0a}$  is less than  $T_e - 50^\circ\text{C}$ , additional cooling equipment is necessary, and greater variation will result in the material due to the difference between the temperature of the continuous annealing furnace and the temperature of the steel sheet; this temperature was therefore determined as the

lower limit. Also, the upper limit for the holding time was determined to be 20 minutes, because when it is longer than 20 minutes it becomes necessary to expand the equipment.

5 **[0056]** By employing the chemical composition and production method described above, it is possible to produce a dual-phase type high-strength steel sheet with excellent dynamic deformation properties, wherein the microstructure of the steel sheet is a composite microstructure wherein the dominating phase is ferrite, and the second phase is another low temperature product phase containing martensite at a volume fraction from 3%~50% after shaping and working at 5% equivalent strain, and wherein the difference between the quasi-static deformation strength  $\sigma_s$  when deformed in a strain rate range of  $5 \times 10^{-4}$  -  $5 \times 10^{-3}$  (1/s) after pre-deformation of more than 0% and less than or equal to 10% of equivalent strain, and the dynamic deformation strength  $\sigma_d$  measured in a strain rate range of  $5 \times 10^2$  -  $5 \times 10^3$  (1/s) after the aforementioned pre-deformation, i.e. ( $\sigma_d - \sigma_s$ ), is at least 60 MPa, and the work hardening coefficient at 5~10% strain is at least 0.13. The steel sheets according to the invention may be made into any desired product by annealing, tempering rolling, electronic coating or hot-dip coating.

#### 15 Examples

**[0057]** The present invention will now be explained by way of examples.

(Example 1)

20 **[0058]** The 26 steel materials listed in Table 1 (steel nos. 1~26) were heated to 1050~1250°C and subjected to hot rolling, cooling and coiling under the production conditions listed in Table 2, to produce hot rolled steel sheets. As shown in Table 3, the steel sheets satisfying the chemical composition conditions and production conditions according to the invention have a dual-phase structure with a martensite volume fraction of at least 3% and no greater than 50%, and as shown in Fig. 4, the mechanical properties of the hot rolled steel sheets indicated excellent impact absorption properties as represented by a work hardening coefficient of at least 0.13 at 5~10% strain,  $\sigma_d - \sigma_s \geq 60$  MPa, and  $\sigma_{dyn} \geq 0.766 \times TS + 250$ , while also having suitable press formability and weldability.

Table 1 Chemical compositions of steels

Steel No.	Chemical compositions (wt%)																				
	C	Si	Mn	P	S	Al	N	Si+Al+P	Ni	Cr	Cu	Mo	Nb	Ti	V	B	Ca	REM	Mn+Cr	Ceq	Mneq
1	0.08	1.01	1.20	0.02	0.003	0.03	0.003	1.06		0.10									1.30	0.29	1.25
2	0.08	1.01	1.20	0.02	0.003	0.03	0.002	1.06		0.10						0.004			1.30	0.29	1.25
3	0.05	1.20	1.30	0.01	0.001	0.01	0.003	1.22											1.30	0.27	1.30
4	0.15	1.51	1.01	0.02	0.002	0.02	0.002	1.55											1.01	0.32	1.01
5	0.08	0.01	1.30	0.02	0.003	1.20	0.003	1.23											1.30	0.30	1.30
6	0.07	0.01	1.60	0.08	0.003	0.03	0.003	0.12											1.60	0.34	1.60
7	0.07	0.50	1.10	0.07	0.002	0.01	0.002	0.58											1.10	0.25	1.10
8	0.08	0.80	1.20	0.02	0.003	0.50	0.003	1.32											1.20	0.28	1.20
9	0.08	0.01	1.10	0.08	0.002	0.20	0.003	0.29											1.10	0.26	1.10
10	0.07	0.02	0.80	0.01	0.001	0.02	0.002	0.05		0.40									1.20	0.24	1.00
11	0.10	1.00	1.80	0.02	0.001	0.02	0.002	1.04											1.80	0.40	1.80
12	0.08	1.01	1.20	0.02	0.002	0.03	0.002	1.06		0.10								0.005	1.30	0.29	1.25
13	0.08	1.01	1.40	0.02	0.002	0.03	0.003	1.06		0.10									1.50	0.32	1.45
14	0.08	1.01	1.20	0.02	0.002	0.03	0.003	1.06		0.10									1.30	0.29	1.25
15	0.01	0.01	1.00	0.01	0.002	0.01	0.005	0.03											1.00	0.18	1.00
16	0.06	0.90	1.20	0.02	0.001	0.01	0.002	0.93	0.5		1.0								1.20	0.39	1.95
17	0.07	0.90	0.90	0.02	0.001	0.01	0.003	0.93				0.5							0.90	0.26	1.15
18	0.09	2.16	1.91	0.01	0.003	0.03	0.003	2.20		0.09			0.02						2.00	0.42	1.96
19	0.06	0.80	1.10	0.02	0.002	0.01	0.002	0.83							0.05				1.10	0.24	1.10
20	0.07	0.90	1.20	0.01	0.001	0.01	0.003	0.92								0.003			1.20	0.27	1.20
21	0.05	1.00	1.36	0.01	0.003	0.02	0.003	1.03		0.90									2.26	0.35	1.81
22	0.07	0.02	1.80	0.08	0.003	0.02	0.002	0.12											1.80	0.37	1.80
23	0.10	0.20	0.81	0.08	0.003	0.02	0.002	0.30											0.81	0.24	0.81
24	0.09	0.20	1.15	0.01	0.005	0.05	0.003	0.26											1.15	0.28	1.15
25	0.08	1.61	1.71	0.01	0.003	0.03	0.003	1.65						0.12					1.71	0.37	1.71
26	0.40	0.002	0.10	0.005	0.010	0.01	0.003	0.017											0.10	0.42	0.10

Underlined data indicate values outside of the range of the invention.

Table 1 (cont.) Chemical compositions of steels

Steel No.	Transformation temperature °C			Type
	Ac1	Ac3	Ar3	
1	741	863	793	present invention
2	741	863	793	present invention
3	744	880	805	present invention
4	756	871	809	present invention
5	709	863	756	present invention
6	706	816	731	present invention
7	726	851	794	present invention
8	733	874	791	present invention
9	712	834	774	present invention
10	722	830	787	present invention
11	733	839	736	present invention
12	741	863	793	present invention
13	739	857	775	comparative example
14	741	863	793	comparative example
15	713	861	806	comparative example
16	728	839	732	present invention
17	740	887	802	present invention
18	767	889	763	present invention
19	735	870	807	present invention
20	736	862	798	present invention
21	753	860	751	present invention
22	704	810	713	present invention
23	720	837	801	present invention
24	717	826	773	present invention
25	752	923	771	present invention
26	722	779	762	comparative example

Table 2 Production conditions

Steel No.	Hot rolling conditions							Cooling conditions				
	Finishing temp. °C	Initial steel strip thickness (mm)	Final pass rolling speed (mpm)	Final sheet thickness (mm)	Strain rate (/sec)	log A calculated	ΔT °C	Inequality (2)	Aver. cooling rate (°C/sec)	Note	Coiling temp. °C	Inequality (3)
1	880	50	1000	1.2	300	14.4	140	0	120	#1	100	0
2	780	26	500	2.9	90	15.0	150	0	30	#1	300	0
3	830	30	600	2.9	140	14.8	160	0	60		200	0
4	820	28	700	1.4	190	14.6	155	0	70		310	0
5	840	35	500	2.3	95	14.3	120	0	50		150	0
6	845	40	600	2.3	145	14.1	140	0	60		150	0
7	830	35	650	2.3	150	14.9	150	0	50		150	0
8	825	38	750	1.6	190	14.9	60	0	60		150	0
9	850	36	600	1.8	150	14.6	170	0	40		150	0
10	840	40	600	1.8	150	15.0	130	0	50		150	0
11	800	26	550	1.8	145	14.0	110	0	40		200	0
12	845	32	600	1.8	150	14.5	135	0	50		100	0
13	930	20	500	1.8	135	13.3	100	0	15		500	x
14	700	26	300	1.8	100	16.1	125	0	15		320	0
15	850	30	600	1.8	150	15.4	150	0	4		310	0
16	840	28	500	1.4	150	13.7	80	0	30		150	0
17	830	28	500	1.4	145	14.9	100	0	30		150	0
18	860	30	700	1.4	190	13.4	50	0	35		100	0
19	840	30	700	1.4	180	15.0	180	0	30		200	0
20	830	30	700	1.4	190	14.9	130	0	30		200	0
21	840	30	700	1.4	190	14.1	140	0	30		200	0
22	780	30	700	1.4	190	14.6	90	0	25		200	0

5  
10  
15  
20  
25  
30  
35  
40  
45  
50  
55

(continued)

Steel No.	Hot rolling conditions							Cooling conditions			Coiling conditions	
	Finishing temp. °C	Initial steel strip thickness (mm)	Final pass rolling speed (mpm)	Final sheet thickness (mm)	Strain rate (/sec)	log A calculated	ΔT °C	Inequality (2)	Aver. cooling rate (°C/sec)	Note	Coiling temp. °C	Inequality (3)
23	800	30	700	1.4	190	15.6	110	o	25		200	o
24	810	30	700	1.4	190	15.0	120	o	25		200	o
25	820	30	700	1.4	190	14.2	40	o	25		200	o
26	880	30	700	1.4	190	13.2	<u>220</u>	<u>x</u>	15		320	o

Underlined data indicate values outside of the range of the invention. \*1: 750 °C~100 C at 15 °C/sec.

Table 3 Microstructure of steels

Steel No.	Dominant phase		Ferrite	Martensite	
	Phase	Circle equivalent diameter (μm)	Volume fraction (%)	Circle equivalent diameter (μm)	Volume fraction after 5% working (%)
1	ferrite	5.5	80	2.5	15
2	ferrite	4.0	90	1.8	8
3	ferrite	5.0	85	2.2	10
4	ferrite	4.0	80	1.8	4
5	ferrite	4.5	80	2.0	20
6	ferrite	5.0	85	2.2	15
7	ferrite	4.5	90	2	10
8	ferrite	4.5	90	2	10
9	ferrite	5.0	90	2.2	10
10	ferrite	5.0	90	2.2	10
11	ferrite	4.0	80	1.7	20
12	ferrite	5.0	90	2.2	10
13	ferrite	<u>11.0</u>	50	-	<u>0</u>
14	ferrite	<u>Worked structure</u>	90	-	<u>0</u>
15	ferrite	10.0	95	-	<u>0</u>
16	ferrite	4.4	90	1.9	10
17	ferrite	4.5	91	2	9
18	ferrite	3.4	78	1.4	22
19	ferrite	4.4	91	1.9	9
20	ferrite	4.3	88	1.8	12
21	ferrite	4.5	85	2	13
22	ferrite	4.4	84	1.9	11
23	ferrite	4.4	85	1.9	8
24	ferrite	4.4	85	1.8	12
25	ferrite	2.4	80	1	10
26	<u>bainite</u>	<u>10.5</u>	<u>30</u>	-	<u>0</u>

Underlined data indicate values outside of the range of the invention.

Table 4 Mechanical properties of steels

Steel No.	Static tension (strain rate = 0.001/s)										Pre-deformation and BH treatment		
	TS Mpa	YS Mpa	T.EI %	TS' (5) Mpa	5-10% n value	YS x n	YS/TS' (5)	TS x T.EI Mpa·%	Form of pre-deformation	Equivalent strain %	BH treatment		
1	680	475	27	720	0.17	81	0.66	18360	C-directional uniaxial tension	5%	yes		
2	630	440	35	665	0.19	84	0.66	22050	C-directional uniaxial tension	5%	no		
3	580	405	32	610	0.18	73	0.66	18560	L-directional uniaxial tension	5%	yes		
4	780	545	28	815	0.19	104	0.67	21840	C-directional uniaxial tension	2%	yes		
5	700	455	29	740	0.20	91	0.61	20300	C-directional uniaxial tension	5%	yes		
6	660	430	30	695	0.19	82	0.62	19800	C-directional uniaxial tension	10%	yes		
7	650	420	31	685	0.21	88	0.61	20150	C-directional uniaxial tension	5%	yes		
8	620	400	32	645	0.21	84	0.62	19840	C-directional uniaxial tension	5%	yes		
9	640	415	31	675	0.18	75	0.61	19840	C-directional uniaxial tension	5%	yes		
10	670	435	30	710	0.19	83	0.61	20100	C-directional uniaxial tension	5%	yes		
11	850	510	24	885	0.21	107	0.58	20400	C-directional uniaxial tension	5%	yes		
12	650	420	31	685	0.20	84	0.61	20150	Equal biaxial tension	5%	yes		
13	520	494	31	530	0.12	59	0.93	16120	C-directional uniaxial tension	5%	yes		
14	500	375	28	515	0.10	38	0.73	14000	Equal biaxial tension	5%	yes		
15	420	310	36	430	0.12	37	0.72	15120	L-directional uniaxial tension	5%	yes		
16	650	390	31	685	0.20	78	0.57	20150	L-directional uniaxial tension	5%	yes		
17	640	380	30	670	0.21	80	0.57	19200	L-directional uniaxial tension	5%	yes		
18	840	505	27	870	0.16	81	0.58	22680	L-directional uniaxial tension	5%	yes		
19	660	405	28	695	0.20	81	0.58	18480	L-directional uniaxial tension	5%	yes		
20	660	400	29	690	0.20	80	0.58	19140	L-directional uniaxial tension	5%	yes		
21	660	480	28	695	0.15	72	0.69	18480	L-directional uniaxial tension	5%	yes		
22	620	290	31	650	0.25	73	0.45	19220	L-directional uniaxial tension	5%	yes		
23	640	420	29	670	0.18	76	0.63	18560	L-directional uniaxial tension	5%	yes		
24	640	380	29	675	0.19	72	0.56	18360	L-directional uniaxial tension	5%	yes		
25	820	615	23	875	0.15	92	0.70	18860	L-directional uniaxial tension	5%	yes		
26	400	290	30	410	0.10	29	0.71	12000	L-directional uniaxial tension	5%	yes		

Underlined data indicate values outside of the range of the invention.

\*3  $\sigma_{dyn} = (0.766 \times TS + 250)$

\*4  $2.5\{YS/TS'(5)-0.5\} + 15 \geq$  plastic deformation  $T \geq 2.5\{YS/TS'(5)-0.5\} + 0.5$

Table 4 (cont.) Mechanical properties of steels

Steel No.	Static/dynamic tension after pre-deformation.BH treatment (strain rate = 1000/s)										Plastic deformation		Other properties
	5% WH*1 Mpa	ΔYS*2 Mpa	σs Mpa	σd Mpa	σd-σs Mpa	σdyn Mpa	Inequality *3	T %	Inequality *4 satisfied	Weldability d/d0			
1	140	205	720	841	121	825	54.1	1.0	0	OK	1.31		
2	150	215	665	788	123	771	38.4	1.0	0	OK	1.45		
3	145	210	610	732	122	718	23.7	1.0	0	OK	1.54		
4	80	150	800	923	123	903	55.5	1.0	0	OK	1.21		
5	140	210	740	864	124	847	60.8	0.9	0	OK	1.27		
6	155	260	710	833	123	830	74.4	0.9	0	OK	1.35		
7	145	215	685	810	125	794	46.1	0.9	0	OK	1.37		
8	140	215	645	770	125	755	30.1	0.9	0	OK	1.44		
9	140	210	675	797	122	781	40.8	0.9	0	OK	1.39		
10	140	210	710	833	123	818	54.8	0.9	0	OK	1.33		
11	150	220	885	1010	125	992	90.9	0.8	0	OK	1.20		
12	140	210	685	809	124	793	45.1	0.9	0	OK	1.40		
13	15	20	530	575	45	565	-83.3	1.6	0	OK	1.71		
14	20	25	515	565	50	555	-78.0	0.1	≠	OK	1.18		
15	25	35	430	485	55	476	-95.7	1.2	0	OK	1.90		
16	140	210	685	809	124	793	45.1	0.7	0	OK	1.37		
17	140	215	670	795	125	780	39.8	0.7	0	OK	1.39		
18	145	210	870	989	119	972	78.6	0.8	0	OK	1.20		
19	140	210	695	819	124	804	48.4	0.8	0	OK	1.35		
20	140	210	690	814	124	798	42.4	0.8	0	OK	1.35		
21	125	195	695	813	118	799	43.4	1.0	0	OK	1.35		
22	145	215	650	779	129	765	40.1	0.4	0	OK	1.44		
23	130	200	670	792	122	777	36.8	0.9	0	OK	1.39		
24	140	210	675	798	123	784	43.8	0.7	0	OK	1.35		
25	120	190	875	993	118	977	98.9	1.1	0	OK	1.20		
26	25	35	410	445	35	437	-119.4	1.1	0	pool	1.50		

Underlined data indicate values outside of the range of the invention.

\*3: σdyn - (0.766 x TS + 250) \*4:2.5{YS/TS' (5)-0.5} + 15 ≥ plastic deformation T ≥ 2.5{YS/TS' (5)-0.5} + 0.5

(Example 2)

**[0059]** The 22 steel materials listed in Table 5 (steel nos. 27-48) were heated to 1050~1250°C and subjected to hot rolling, cooling and coiling, followed by acid pickling and then cold rolling under the conditions listed in Table 6 to produce cold rolled steel sheets. Temperatures  $Ac_1$  and  $Ac_3$  were then calculated from the chemical compositions for each steel, and the sheets were subjected to heating, cooling and holding under the annealing conditions listed in Table 6, prior to cooling to room temperature. As shown in Table 7, the steel sheets satisfying the chemical composition conditions and production conditions according to the invention have a dual-phase structure with a martensite volume fraction of at least 3% and no greater than 50% and, as shown in Fig. 8, the mechanical properties of the hot-rolled steel sheets indicated excellent impact absorption properties as represented by a work hardening coefficient of at least 0.13 at 5~10% strain,  $\sigma_d - \sigma_s \geq 60$  MPa, and  $\sigma_{dyn} \geq 0.766 \times TS + 250$ , while also having suitable press formability and weldability.

5

10

15

20

25

30

35

40

45

50

55

Table 5 Chemical compositions of steel  
Chemical compositions (wt%)

Steel No.	Chemical compositions (wt%)																Transformation temperature °C			Type			
	C	Si	Mn	P	S	Al	N	Al+Si +P	Ni	Cr	Cu	Mo	Nb	Ti	V	B	Mn+Cr	Ceq	Mneq		AC1	AC3	Ar3
27	<u>0.01</u>	1.00	0.10	0.01	0.003	0.04	0.003	1.05									0.10	0.03	0.10	751	934	922	comp. ex.
28	0.05	0.90	1.20	0.01	0.005	0.05	0.002	0.96									1.20	0.25	1.20	736	872	804	invention
29	0.05	0.90	1.20	0.01	0.005	0.05	0.002	0.96									1.20	0.25	1.20	736	872	804	comp. ex.
30	0.05	0.90	1.20	0.01	0.005	0.05	0.002	0.96									1.20	0.25	1.20	736	872	804	comp. ex.
31	0.05	1.30	1.20	0.01	0.002	0.04	0.003	1.35									1.20	0.25	1.20	748	889	817	invention
32	0.08	1.00	1.20	0.01	0.003	0.05	0.002	1.06									1.20	0.28	1.20	739	864	798	invention
33	0.08	0.20	0.70	0.01	0.003	0.04	0.003	0.25									0.70	0.20	0.70	721	843	817	invention
34	0.10	0.02	2.10	0.01	0.002	0.03	0.003	0.06									2.10	0.45	2.10	701	785	676	invention
35	0.08	0.80	1.00	0.01	0.003	1.20	0.002	2.01									1.00	0.25	1.00	736	907	809	invention
36	0.05	0.50	1.00	0.01	0.005	0.80	0.003	1.31									1.00	0.22	1.00	727	890	809	invention
37	0.05	1.00	1.00	0.01	0.003	0.05	0.002	1.06	0.9								1.00	0.29	1.45	726	869	784	invention
38	0.05	1.00	1.00	0.01	0.005	0.04	0.003	1.05		1.0							1.00	0.30	1.50	741	862	780	invention
39	0.05	1.00	1.00	0.01	0.003	0.04	0.003	1.05			0.1						1.00	0.23	1.05	741	885	821	invention
40	0.05	1.00	1.50	0.01	0.005	0.05	0.002	1.06		1.0							2.50	0.38	2.00	753	856	734	invention
41	0.10	1.00	1.50	0.01	0.003	0.46	0.002	1.47				0.04					1.50	0.35	1.50	736	865	764	invention
42	0.10	1.00	1.50	0.01	0.005	0.04	0.002	1.05						0.04			1.50	0.35	1.50	736	864	764	invention
43	0.10	1.00	1.50	0.10	0.003	0.05	0.003	1.15						0.01	0.04		1.50	0.35	1.50	736	863	764	invention
44	0.10	1.00	1.50	0.01	0.003	0.04	0.003	1.05				0.02				0.002	1.50	0.35	1.50	736	848	764	invention
45	0.10	0.01	1.50	0.003	0.003	0.002	0.003	0.015									1.50	0.35	1.50	707	802	731	comp. ex.
46	<u>0.35</u>	1.00	1.20	0.01	0.002	0.05	0.003	1.06									1.20	0.55	1.20	739	801	710	comp. ex.
47	0.05	0.80	2.50	0.01	0.003	0.04	0.002	0.85	2.0								<u>4.50</u>	0.63	3.50	753	806	589	comp. ex.
48	0.08	<u>3.50</u>	1.50	0.25	0.003	0.80	0.003	<u>4.55</u>									1.50	0.33	1.50	809	1014	853	comp. ex.

Underlined data indicate values outside of the range of the invention.

Table 7 Microstructure of steels

Steel No.	Dominant phase		Ferrite	Martensite	
	Phase	Circle equivalent diameter ( $\mu\text{m}$ )	Volume fraction (%)	Circle equivalent diameter ( $\mu\text{m}$ )	Volume fraction after 5% working (%)
27	ferrite	9.8	100	--	<u>0</u>
28	ferrite	6.4	86	3.2	12
29	ferrite	6.4	95	--	<u>1</u>
30	ferrite	6.4	94	--	<u>0</u>
31	ferrite	5.3	89	3.1	11
32	ferrite	4.8	82	2.8	15
33	ferrite	5.1	84	2.9	12
34	ferrite	4.8	75	2.2	18
35	ferrite	5.1	90	2.3	10
36	ferrite	5.5	90	2.8	8
37	ferrite	6.2	89	3.1	11
38	ferrite	5.8	81	3.0	16
39	ferrite	5.6	78	3.2	18
40	ferrite	5.6	87	3.2	13
41	ferrite	4.2	80	1.7	16
42	ferrite	4.5	78	2.1	18
43	ferrite	4.3	79	2.2	19
44	ferrite	5.0	79	2.3	13
45	ferrite	4.9	81	2.1	<u>1</u>
46	ferrite	4.1	42	2.4	35
47	ferrite	4.6	51	2.6	25
48	ferrite	5.6	88	2.6	12

Underlined data indicate values outside of the range of the invention.

Table 8 Mechanical properties ( steels

Steel No.	Static tension (strain rate = 0.001/s)										Pre-deformation and BH treatment		
	TS Mpa	YS Mpa	T.E1 %	TS' (5) Mpa	5-10% n value	YS x n	YS/TS' (5)	TS x T.E1 Mpa · %	Form of pre-deformation	Equivalent strain %	BH treatment		
27	357	243	48	357	0.28	<u>68</u>	0.68	<u>17136</u>	C-directional uniaxial tension	5	yes		
28	592	349	34	630	0.24	84	0.55	20128	C-directional uniaxial tension	5	no		
29	603	457	32	612	0.20	91	<u>0.75</u>	19296	C-directional uniaxial tension	5	no		
30	583	472	26	591	0.15	71	<u>0.80</u>	<u>15150</u>	C-directional uniaxial tension	5	no		
31	599	341	33	621	0.23	79	0.55	19767	L-directional uniaxial tension	10	yes		
32	641	359	34	690	0.23	83	0.52	21794	C-directional uniaxial tension	5	yes		
33	558	340	36	597	0.26	88	0.57	20088	C-directional uniaxial tension	5	yes		
34	640	397	33	650	0.22	87	0.61	21120	C-directional surface strain tension	3	yes		
35	611	354	35	633	0.23	82	0.56	21385	C-directional uniaxial tension	5	yes		
36	589	324	36	600	0.24	78	0.54	21204	C-directional uniaxial tension	5	yes		
37	634	361	33	657	0.21	76	0.55	20922	Equal biaxial tension	10	yes		
38	625	388	31	668	0.19	74	0.58	19375	C-directional uniaxial tension	5	yes		
39	689	434	29	712	0.18	78	0.61	19981	L-directional uniaxial tension	1	no		
40	623	368	32	623	0.20	74	0.59	19936	C-directional uniaxial tension	1	yes		
41	709	425	26	721	0.17	72	0.59	18434	C-directional uniaxial tension	5	yes		
42	722	448	25	734	0.17	76	0.61	18050	C-directional uniaxial tension	5	no		
43	731	468	25	755	0.16	75	0.62	18275	Equal biaxial tension	5	yes		
44	715	465	26	726	0.16	74	0.64	18590	C-directional uniaxial tension	5	yes		
45	648	531	25	681	<u>0.12</u>	<u>64</u>	<u>0.78</u>	16200	C-directional uniaxial tension	5	yes		
46	1075	742	10	1075	<u>0.08</u>	<u>59</u>	<u>0.69</u>	<u>10750</u>	C-directional uniaxial tension	5	yes		
47	712	484	21	712	<u>0.11</u>	<u>53</u>	0.68	<u>14952</u>	C-directional uniaxial tension	5	yes		
48	792	475	22	792	0.14	<u>67</u>	0.60	<u>17424</u>	C-directional uniaxial tension	5	yes		

Underlined data indicate values outside of the range of the invention.

Table 8 (cont.) Mechanical properties of steels

Steel No.	Static/dynamic tension after pre-deformation-BH treatment (strain rate = 1000/s)										Plastic deformation		Weldability
	5% WH*1 Mpa	$\Delta YS^*2$ Mpa	$\sigma_s$ Mpa	$\sigma_d$ Mpa	$\sigma_d - \sigma_s$ Mpa	$\sigma_{dyn}$ Mpa	Inequality *3	T Z	Inequality *4 satisfied				
27	90	116	390	438	48	412	-111.5	1.0	0	OK			
28	182	260	630	734	104	721	17.5	1.0	0	OK			
29	102	127	620	662	42	645	-66.9	1.5	0	OK			
30	97	115	593	626	33	599	-97.6	1.5	0	OK			
31	240	297	740	846	106	798	89.2	1.0	0	OK			
32	212	294	757	818	61	786	45.0	1.0	0	OK			
33	143	212	607	686	79	680	2.6	1.0	0	OK			
34	191	229	660	748	88	745	4.8	1.0	0	OK			
35	201	275	658	756	98	742	24.0	1.0	0	OK			
36	212	289	612	733	121	722	20.8	1.0	0	OK			
37	257	318	703	790	87	776	40.4	1.0	0	OK			
38	182	244	678	762	84	748	19.3	1.0	0	OK			
39	199	239	712	798	86	789	11.2	4.0	0	OK			
40	201	181	625	748	123	740	12.8	1.0	x	OK			
41	209	280	729	824	95	819	25.9	1.0	0	OK			
42	201	260	734	833	99	818	14.9	1.0	0	OK			
43	182	246	767	829	62	820	10.1	1.0	0	OK			
44	177	253	739	835	96	824	26.3	1.0	0	OK			
45	58	92	696	744	48	712	-34.4	1.0	x	OK			
46	299	341	1076	1088	12	1052	-21.5	1.0	0	poor			
47	181	229	715	757	42	740	-55.4	1.0	0	poor			
48	265	332	806	856	50	832	-24.7	1.0	0	OK			

Underlined data indicate values outside of the range of the invention.

\*1: WH represents increase in YS with 5% pre-deformation at equivalent strain listed in the table.

\*2:  $\Delta YS$  represents increase in YS after pre-deformation in the table and heat treatment as paint baking treatment at 170°C x 20 min.

\*3  $\sigma_{dyn} - (0.766 \times TS + 250)$

\*4  $2.5\{YS/TS\} (5) - 0.5 + 15 \geq$  plastic deformation T  $\geq 2.5\{YS/TS\} (5) - 0.5 + 0.5$

[0060] The microstructure was evaluated by the following method.

[0061] Identification of the ferrite, bainite, martensite and residual structure, observation of the location and measurement of the average grain size (mean circle equivalent diameter) was accomplished using a 1000 magnification optical micrograph with the thin steel sheet rolling direction cross-section etched with a nital and the reagent disclosed in Japanese Unexamined Patent Publication No. 59-219473.

[0062] The properties were evaluated by the following methods.

[0063] A tensile test was conducted according to JIS5 (gauge mark distance: 50 mm, parallel part width: 25 mm) with a strain rate of 0.001/s and, upon determining the tensile strength (TS), yield strength (YS), total elongation (T. El) and work hardening coefficient (n value for 1%~5% strain), the YS x work hardening coefficient and TS x T. El. were calculated.

[0064] The stretch flanging property was measured by expanding a 20 mm punched hole from the burrless side with a 30° cone punch, and determining the hole expansion ratio (d/d<sub>0</sub>) between the hole diameter (d) at the moment at which the crack penetrated the plate thickness and the original hole diameter (d<sub>0</sub>, 20 mm).

[0065] The spot weldability was judged to be unsuitable if a spot welding test piece bonded at a current of 0.9 times the expulsion current using an electrode with a tip radius of 5 times the square root of the steel sheet thickness underwent peel fracture when ruptured with a chisel.

[0066] As explained above, the present invention makes it possible to provide, in an economical and stable manner, high-strength hot rolled steel sheets and cold rolled steel sheets for automobiles which provide previously unobtainable excellent impact absorption properties and press formability and thus offers a markedly wider range of objects and conditions for uses of high-strength steel sheets.

## Claims

1. A method of producing a dual-phase high-strength hot-rolled steel sheet having high impact energy absorption properties, **characterized in that** a continuous cast slab containing, in terms of weight percentage, C: 0.02-0.25%, either or both Mn and Cr in a total amount of 0.15-3.5%, one or more selected from Si, Al and P in a total amount of 0.02-4.0%, optionally one or more selected from Ni, Cu and Mo in a total amount of no more than 3.5%, optionally one or more selected from Nb, Ti and V in an amount of no more than 0.30%, and optionally either or both Ca and REM in an amount of 0.0005-0.01 % for Ca and 0.005-0.05% for REM, further optionally one or more selected from B of no more than 0.01%, S of no more than 0.01% and N of no more than 0.02%, with the remainder being Fe and unavoidable impurities, is fed directly from casting to a hot rolling step, or is hot rolled upon reheating after momentary cooling, it is subjected to hot rolling at a finishing temperature of Ar<sub>3</sub> - 50°C to Ar<sub>3</sub> + 120°C, the hot rolling is carried out so that the metallurgy parameter A satisfies inequalities (1) and (2) below, the subsequent average cooling rate in the run-out table is at least 5°C/sec, and the coiling is accomplished so that the relationship between said metallurgy parameter A and the coiling temperature (CT) satisfies inequality (3) below:

$$9 \leq \log A \leq 18 \quad (1)$$

$$\Delta T \leq 21 \times \log A - 61 \quad (2)$$

$$CT \leq 6 \times \log A + 242 \quad (3)$$

wherein, metallurgy parameter A is expressed by the following equation:

$$A = \varepsilon^* \times \exp\{(75282 - 42745 \times C_{eq}) / [1.978 \times (FT + 273)]\}$$

wherein:

FT: finishing temperature (°C)

C<sub>eq</sub>: carbon equivalents = C + Mn<sub>eq</sub>/6 (%)

EP 0 969 112 B1

$Mn_{eq}$ : manganese equivalents =  $Mn + (Ni + Cr + Cu + Mo) / 2$  (%)

$\varepsilon^*$ : final pass strain rate ( $s^{-1}$ )

$$\varepsilon^* = (v / \sqrt{R \times h_1}) \times (1/\sqrt{r}) \times \ln \{1 / (1 - r)\}$$

$h_1$ : final pass approach sheet thickness.

$h_2$ : final pass exit sheet thickness

$r$ :  $(h_1 - h_2) / h_1$

$R$ : roll radius

$v$ : final pass exit speed

$\Delta T$ : finishing temperature (finishing final pass exit temperature) - finishing approach temperature (finishing first pass approach temperature)

$$Ar_3: 901 - 325 C\% + 33 Si\% - 92 Mn_{eq}.$$

2. A method of producing a dual-phase type high-strength cold-rolled steel sheet having high impact energy absorption properties, **characterized in that** a continuous cast slab containing, in terms of weight percentage, C: 0.02-0.25%, either or both Mn and Cr in a total amount of 0.15-3.5%, one or more selected from Si, Al and P in a total amount of 0.02-4.0%, optionally one or more selected from Ni, Cu and Mo in a total amount of no more than 3.5%, optionally one or more selected from Nb, Ti and V in an amount of no more than 0.30%, and optionally either or both Ca and REM in an amount of 0.0005-0.01 % for Ca and 0.005-0.05% for REM, further optionally one or more selected from B of no more than 0.01 %, S of no more than 0.01 % and N of no more than 0.02%, with the remainder being Fe and unavoidable impurities, is fed directly from casting to a hot rolling step, or is hot rolled upon reheating after momentary cooling, it is hot rolled, the hot rolled and subsequently coiled steel sheet is cold rolled after acid pickling, and during annealing in a continuous annealing step for preparation of the final product, the cold rolled steel sheet is heated to an annealing temperature ( $T_0$ ) between  $Ac_1$  and  $Ac_3$  and subjected to the annealing while held in this temperature range for at least 10 seconds, and subsequently it is cooled with a primary cooling rate of  $1 - 10^\circ C/sec$  to a secondary cooling start temperature ( $T_q$ ) in the range of  $550 - 720^\circ C$  and then cooled with a secondary cooling rate of  $10 - 200^\circ C/sec$  to a secondary cooling end temperature ( $T_e$ ) which is no higher than a temperature ( $T_{em}$ ), wherein  $T_{em}$  is the martensite transformation start temperature for the retained austenite at the secondary cooling start temperature  $T_q$  and defined by  $T_{em} = T_1 - T_2$ , wherein:

$$T_1 = 561 - 33 \times \{Mn\% + (Ni + Cr + Cu + Mo) / 2\},$$

$T_2 = 474 \times (Ac_3 - Ac_1) \times C / (T_0 - Ac_1)$  when  $Ceq^* = (Ac_3 - Ac_1) \times C / (T_0 - Ac_1) + (Mn + Si/4 + Ni/7 + Cr + Cu + 1.5Mo) / 6$  is greater than 0.6, and

$T_2 = 474 \times (Ac_3 - Ac_1) \times C / \{3 \times (Ac_3 - Ac_1) \times C + [(Mn + Si/4 + Ni/7 + Cr + Cu + 1.5Mo) / 2 - 0.85] \times (T_0 - Ac_1)\}$  when  $Ceq^*$  is 0.6 or less,

wherein:

$$Ac_1 = 723 - 0.7 \times Mn\% - 16.9 \times Ni\% + 29.1 \times Si\% + 16.9 \times Cr\%,$$

$$Ac_3 = 910 - 203 \times (C\%)^{1/2} - 15.2 \times Ni\% + 44.7 \times Si\% + 104 \times V\% + 31.5 \times Mo\% - 30 \times Mn\% - 11 \times Cr\% - 20 \times Cu\% + 70 \times P\% + 40 \times Al\% + 400 \times Ti\%.$$

## 10 Patentansprüche

1. Verfahren zur Herstellung eines hochfesten warmgewalzten Dualphasen-Stahlblechs mit hohen Aufprallenergie-Absorptionseigenschaften, **dadurch gekennzeichnet, dass** eine Stranggussbramme, die in Gewichtsprozent 0,02-0,25 % C, eine Gesamtmenge von 0,15-3,5 % Mn und/oder Cr, eine Gesamtmenge von 0,02-4,0 % Si und/oder Al und/oder P, optional eine Gesamtmenge von höchstens 3,5 % Ni und/oder Cu und/oder Mo, optional eine Menge von höchstens 0,30 % Nb und/oder Ti und/oder V sowie optional Ca und/oder SEM in einer Menge von 0,0005-0,01 % für Ca und 0,005-0,05 % für SEM, ferner optional höchstens 0,01 % B und/oder höchstens 0,01 % S und/oder höchstens 0,02 % N sowie als Rest Fe und unvermeidliche Verunreinigungen enthält, direkt vom Gießen einem Warmwalzschritt zugeführt oder nach Nachwärmen nach vorübergehender Abkühlung warmgewalzt wird, wobei das Warmwalzen bei einer Endtemperatur von  $Ar_3 - 50 \text{ °C}$  bis  $Ar_3 + 120 \text{ °C}$  erfolgt und so durchgeführt wird, dass der Metallurgieparameter A die nachstehenden Ungleichungen (1) und (2) erfüllt, die anschließende mittlere Abkühlungsgeschwindigkeit im Auslaufrollgang mindestens  $5 \text{ °C/s}$  beträgt und das Wickeln so realisiert wird, dass die Beziehung zwischen dem Metallurgieparameter A und der Wickeltemperatur (CT) die nachstehende Ungleichung (3) erfüllt:

$$9 \leq \log A \leq 18 \quad (1),$$

$$\Delta T \leq 21 \times \log A - 61 \quad (2),$$

$$CT \leq 6 \times \log A + 242 \quad (3),$$

wobei der Metallurgieparameter A durch die folgende Gleichung ausgedrückt ist:

$$A = \varepsilon^* \times \exp\{ (75282 - 42745 \times C_{eq}) / [1,978 \times (FT + 273)] \},$$

wobei:

- FT: Endtemperatur (°C),  
 $C_{eq}$ : Kohlenstoffäquivalente =  $C + Mn_{eq}/6$  (%),  
 $Mn_{eq}$ : Manganäquivalente =  $Mn + (Ni + Cr + Cu + Mo) / 2$  (%),  
 $\varepsilon^*$ : Verformungsgeschwindigkeit im Schlichtstich ( $s^{-1}$ ),

$$\varepsilon^* = (v / \sqrt{R \times h_1}) \times (1 / \sqrt{r}) \times \ln\{1 / (1 - r)\},$$

- $h_1$ : Blechdicke am Schlichtsticheinlauf,  
 $h_2$ : Blechdicke am Schlichtstichauslauf,  
 $r$ :  $(h_1 - h_2) / h_1$ ,  
R: Walzenradius,

## EP 0 969 112 B1

v: Geschwindigkeit am Schlichtstichauslauf,

$\Delta T$ : Endtemperatur (Endtemperatur am Schlichtstichauslauf) - Endtemperatur am Einlauf (Endtemperatur am ersten Ansticheinlauf),

5

$$Ar_3: 901 - 325 C\% + 33 Si\% - 92 Mn_{eq}.$$

10

15

20

25

2. Verfahren zur Herstellung eines hochfesten kaltgewalzten Stahlblechs vom Dualphasentyp mit hohen Aufprallenergie-Absorptionseigenschaften, **dadurch gekennzeichnet, dass** eine Stranggussbramme, die in Gewichtsprozent 0,02-0,25 % C, eine Gesamtmenge von 0,15-3,5 % Mn und/oder Cr, eine Gesamtmenge von 0,02-4,0 % Si und/oder Al und/oder P, optional eine Gesamtmenge von höchstens 3,5 % Ni und/oder Cu und/oder Mo, optional eine Menge von höchstens 0,30 % Nb und/oder Ti und/oder V sowie optional Ca und/oder SEM in einer Menge von 0,0005-0,01 % für Ca und 0,005-0,05 % für SEM, ferner optional höchstens 0,01 % B und/oder höchstens 0,01 % S und/oder höchstens 0,02 % N sowie als Rest Fe und unvermeidliche Verunreinigungen enthält, direkt vom Gießen einem Warmwalzschritt zugeführt oder nach Nachwärmen nach vorübergehender Abkühlung warmgewalzt wird, nach dem Warmwalzen das warmgewalzte und anschließend gewickelte Stahlblech nach Säurebeizen kaltgewalzt wird und beim Glühen in einem Durchlaufglühschritt zur Herstellung des Endprodukts das kaltgewalzte Stahlblech auf eine Glühtemperatur ( $T_0$ ) zwischen  $Ac_1$  und  $Ac_3$  erwärmt und beim Glühen mindestens 10 Sekunden in diesem Temperaturbereich gehalten wird, und es anschließend mit einer primären Abkühlungsgeschwindigkeit von 1 - 10 °C/s auf eine sekundäre Abkühlungsanfangstemperatur ( $T_q$ ) im Bereich von 550 - 720 °C abgekühlt und dann mit einer sekundären Abkühlungsgeschwindigkeit von 10 - 200 °C/s auf eine sekundäre Abkühlungsendtemperatur ( $T_e$ ) abgekühlt wird, die nicht höher als eine Temperatur ( $T_m$ ) ist, wobei  $T_m$  die Martensitumwandlungs-Anfangstemperatur für den Restaustenit bei der sekundären Abkühlungsanfangstemperatur  $T_q$  und durch  $T_m = T_1 - T_2$  definiert ist, wobei:

$$T_1 = 561 - 33 \times \{Mn\% + (Ni + Cr + Cu + Mo)/2\},$$

30

$$T_2 = 474 \times (Ac_3 - Ac_1) \times C / (T_0 - Ac_1), \text{ wenn } Ceq^* = (Ac_3 - Ac_1) \times C / (T_0 - Ac_1) + (Mn + Si/4 + Ni/7 + Cr + Cu + 1,5Mo)/6 \text{ größer als } 0,6 \text{ ist, und}$$

35

$$T_2 = 474 \times (Ac_3 - Ac_1) \times C / \{3 \times (Ac_3 - Ac_1) \times C + [(Mn + Si/4 + Ni/7 + Cr + Cu + 1,5Mo)/2 - 0,85] \times (T_0 - Ac_1)\},$$

40

wenn  $Ceq^* \leq 0,6$  oder kleiner ist,  
wobei:

45

$$Ac_1 = 723 - 0,7 \times Mn\% - 16,9 \times Ni\% + 29,1 \times Si\% + 16,9 \times Cr\%,$$

50

$$Ac_3 = 910 - 203 \times (C\%)^{1/2} - 15,2 \times Ni\% + 44,7 \times Si\% + 104 \times V\% + 31,5 \times Mo\% - 30 \times Mn\% - 11 \times Cr\% - 20 \times Cu\% + 70 \times P\% + 40 \times Al\% + 400 \times Ti\%.$$

55

Revendications

1. Procédé pour produire une tôle d'acier laminé à chaud haute résistance biphasique ayant des propriétés de forte absorption de l'énergie d'impact, **caractérisé en ce qu'**un lingot coulé en continu contenant, en pourcentages en poids, C : 0,02 à 0,25 %, l'un ou l'autre ou les deux de Mn et Cr en une quantité totale de 0,15 à 3,5 %, un ou plusieurs choisi(s) parmi Si, Al et P en une quantité totale de 0,02 à 4,0 %, éventuellement un ou plusieurs choisi(s) parmi Ni, Cu et Mo en une quantité totale ne dépassant pas 3,5 %, éventuellement un ou plusieurs choisi(s) parmi Nb, Ti et V en une quantité ne dépassant pas 0,30 %, et éventuellement l'un ou l'autre ou les deux de Ca et REM en une quantité de 0,0005 à 0,01 % pour Ca et de 0,005 à 0,05 % pour REM, en outre éventuellement un ou plusieurs choisi(s) parmi B à raison d'au plus 0,01 %, S à raison d'au plus 0,01 % et N à raison d'au plus 0,02 %, le reste étant Fe et des impuretés inévitables, est introduit directement depuis la coulée vers une étape de laminage à chaud, ou est laminé à chaud lors du réchauffage après refroidissement momentané, est soumis à un laminage à chaud à une température de finissage d'Ar<sub>3</sub> - 50°C à Ar<sub>3</sub> + 120°C, le laminage à chaud est effectué de façon que le paramètre métallurgique A satisfasse aux inégalités (1) et (2) ci-dessous, la vitesse de refroidissement moyenne subséquente dans la table de sortie est d'au moins 5°C/s, et le bobinage est accompli de façon que la relation entre ledit paramètre métallurgique A et la température de bobinage (CT) satisfasse à l'inégalité (3) ci-dessous :

$$9 \leq \log A \leq 18 \tag{1}$$

$$\Delta T \leq 21 \times \log A - 61 \tag{2}$$

$$CT \leq 6 \times \log A + 242 \tag{3}$$

où le paramètre métallurgique A est exprimé par l'équation suivante :  $A = \varepsilon^* \times \exp\{(75282 - 42745 \times C_{eq}) / [1,978 \times (FT + 273)]\}$

dans laquelle :

FT : température de finissage (°C)

C<sub>eq</sub> : équivalents carbone = C + Mn<sub>eq</sub>/6 (%)

Mn<sub>eq</sub> : équivalents manganèse = Mn + (Ni + Cr + Cu + Mo)/2 (%)

ε\* : vitesse de déformation au passage final (s<sup>-1</sup>)

$$\varepsilon^* = (v / \sqrt{R \times h_1}) \times (1/\sqrt{r}) \times \ln \{1 / (1 - r)\}$$

h<sub>1</sub> : épaisseur de tôle à l'approche du passage final

h<sub>2</sub> : épaisseur de tôle à la sortie du passage final

r : (h<sub>1</sub> - h<sub>2</sub>)/h<sub>1</sub>

R : rayon du cylindre

v : vitesse à la sortie du passage final

AT : température de finissage (température à la sortie du passage final de finissage) - température à l'approche du finissage (température à l'approche du premier passage de finissage)

$$Ar_3 : 901 - 325 C\% + 33 Si\% - 92 Mn_{eq}$$

2. Procédé pour produire une tôle d'acier laminé à chaud haute résistance biphasique ayant des propriétés de forte absorption de l'énergie d'impact, **caractérisé en ce qu'**un lingot coulé en continu contenant, en pourcentage en poids, C : 0,02 à 0,25 %, l'un ou l'autre ou les deux de Mn et Cr en une quantité totale de 0,15 à 3,5 %, un ou plusieurs choisi(s) parmi Si, Al et P en une quantité totale de 0,02 à 4,0 %, éventuellement un ou plusieurs choisi(s) parmi Ni, Cu et Mo en une quantité totale ne dépassant pas 3,5 %, éventuellement un ou plusieurs choisi(s)

## EP 0 969 112 B1

5 parmi Nb, Ti et V en une quantité ne dépassant pas 0,30 %, et éventuellement l'un ou l'autre ou les deux de Ca et REM en une quantité de 0,0005 à 0,01 % pour Ca et de 0,005 à 0,05 % pour REM, en outre éventuellement un ou plusieurs choisi(s) parmi B à raison d'au plus 0,01 %, S à raison d'au plus 0,01 % et N à raison d'au plus 0,02 %, le reste étant Fe et des impuretés inévitables, est introduit directement depuis la coulée vers une étape de laminage à chaud, ou est laminé à chaud lors du réchauffage après refroidissement momentané, est laminé à chaud, la tôle d'acier laminée à chaud et ensuite bobinée est laminée à froid après décapage acide et, durant le recuit dans une étape de recuit en continu pour la préparation du produit final, la tôle d'acier laminé à froid est chauffée à une température de recuit ( $T_o$ ) comprise entre  $Ac_1$  et  $Ac_3$  et soumise au recuit tout en étant maintenue dans cette plage de température pendant au moins 10 secondes, et ensuite est refroidie à une vitesse de refroidissement primaire de 1 à 10°C/s jusqu'à une température de début de refroidissement secondaire ( $T_q$ ) située dans la plage allant de 550 à 720°C puis refroidie à une vitesse de refroidissement secondaire de 10 à 200°C/s jusqu'à une température de fin de refroidissement secondaire ( $T_e$ ) qui n'est pas supérieure à une température ( $T_{em}$ ), où  $T_{em}$  est la température de début de transformation en martensite pour l'austénite résiduelle à la température de début de refroidissement secondaire  $T_q$  et est définie par  $T_{em} = T_1 T_2$ , où :

$$T_1 = 561 - 33 \times \{Mn\% + (Ni + Cr + Cu + Mo) / 2\},$$

$$T_2 = 474 \times (Ac_3 - Ac_1) \times C / (T_o - Ac_1) \text{ quand } C_{eq}^* = (Ac_3 - Ac_1) \times C / (T_o - Ac_1) + (Mn + Si/4 + Ni/7 + Cr + Cu + 1,5Mo) / 6 \text{ est supérieur à } 0,6, \text{ et}$$

$$T_2 = 474 \times (Ac_3 - Ac_1) \times C / \{3 \times (Ac_3 - Ac_1) \times C + [(Mn + Si/4 + Ni/7 + Cr + Cu + 1,5Mo) / 2 - 0,85] \times (T_o - Ac_1)\} \text{ quand } C_{eq}^* \text{ vaut } 0,6 \text{ ou moins,}$$

où :

$$Ac_1 = 723 - 0,7 \times Mn\% - 16,9 \times Ni\% + 29,1 \times Si\% + 16,9 \times Cr\%,$$

$$Ac_3 = 910 - 203 \times (C\%)^{1/2} - 15,2 \times Ni\% + 44,7 \times Si\% + 104 \times V\% + 31,5 \times Mo\% - 30 \times Mn\% - 11 \times Cr\% - 20 \times Cu\% + 70 \times P\% + 40 \times Al\% + 400 \times Ti\%.$$

Fig.1

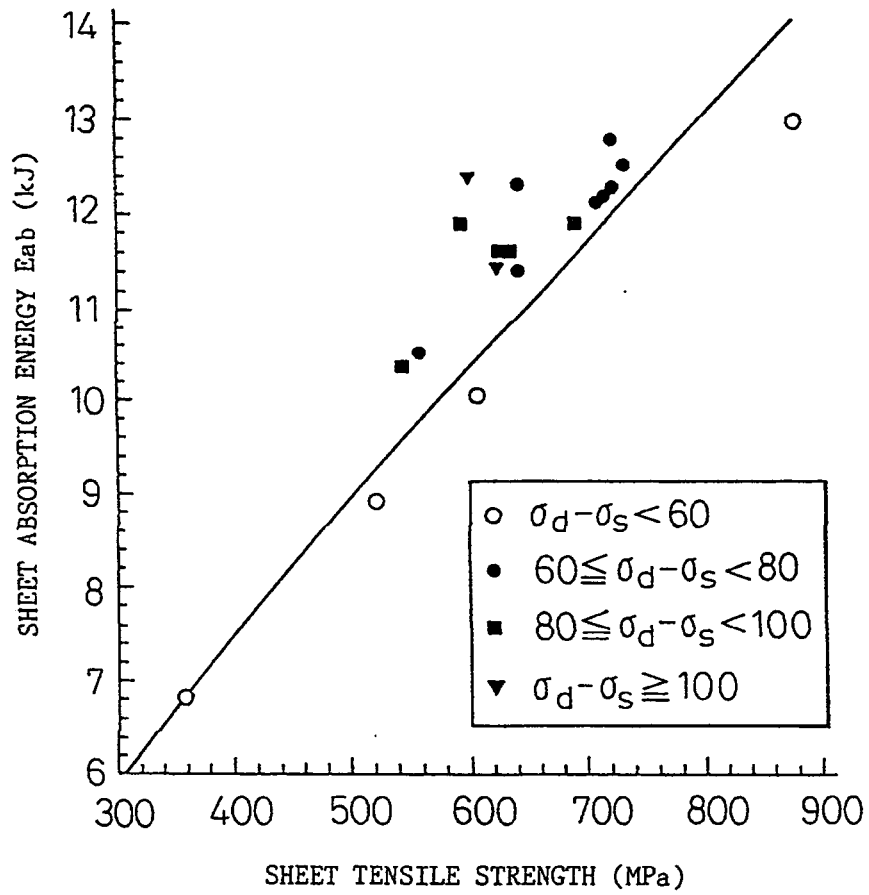
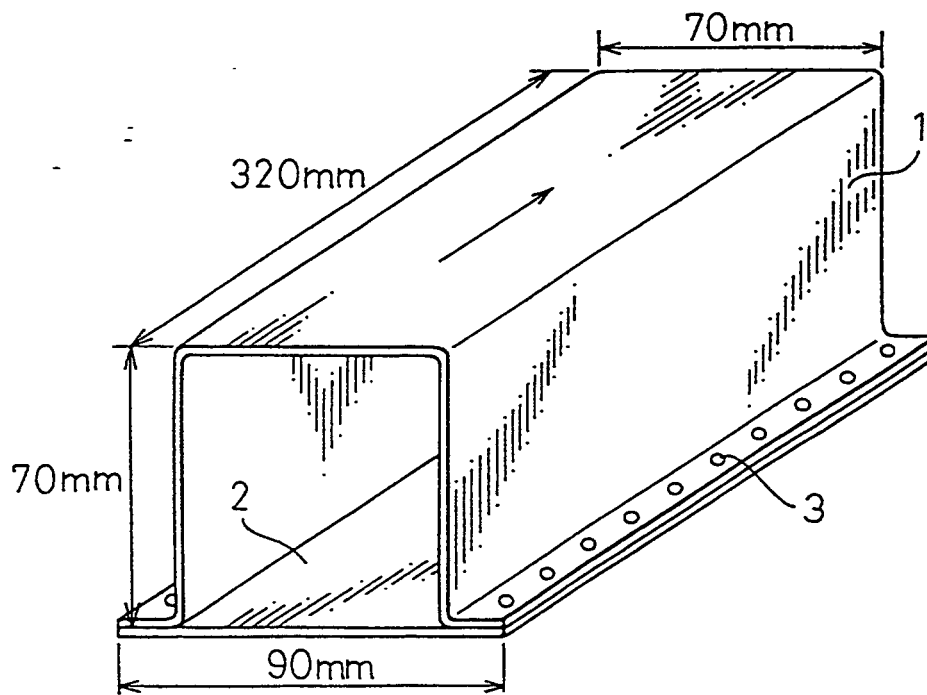
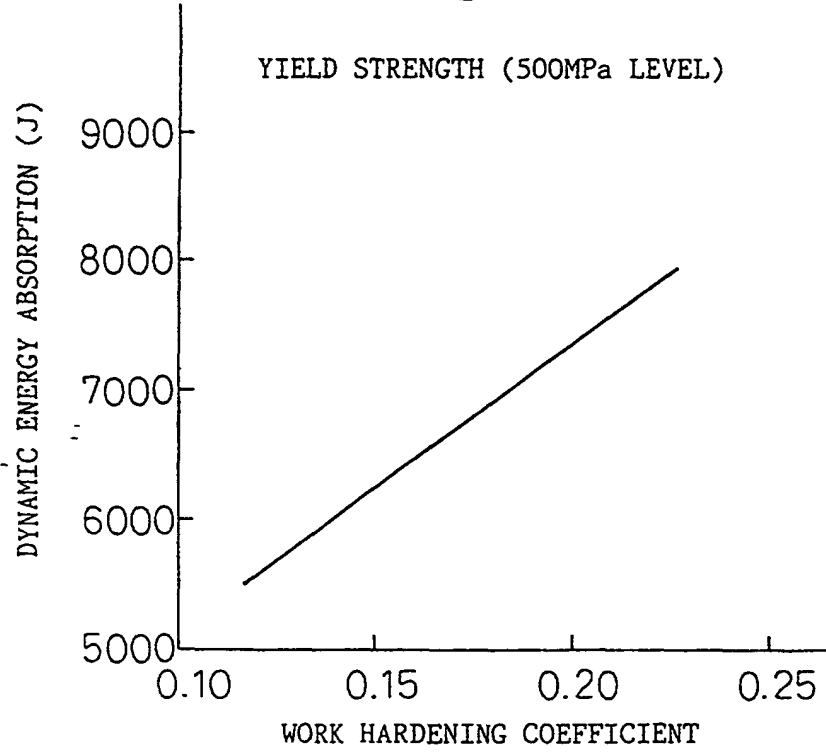

Fig.2



# Fig.3



# Fig.4

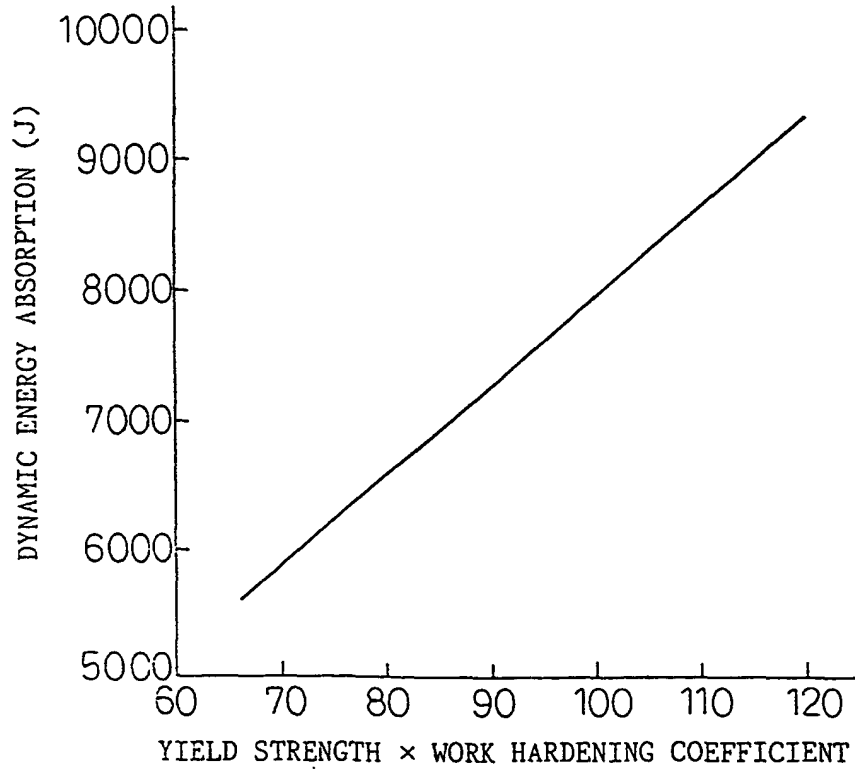

Fig.5

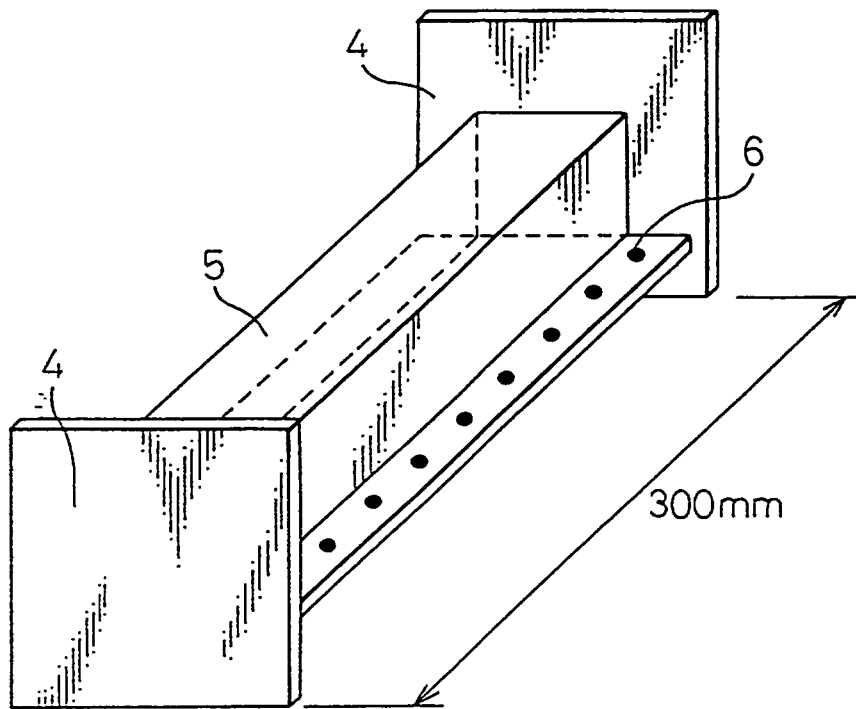

Fig.6

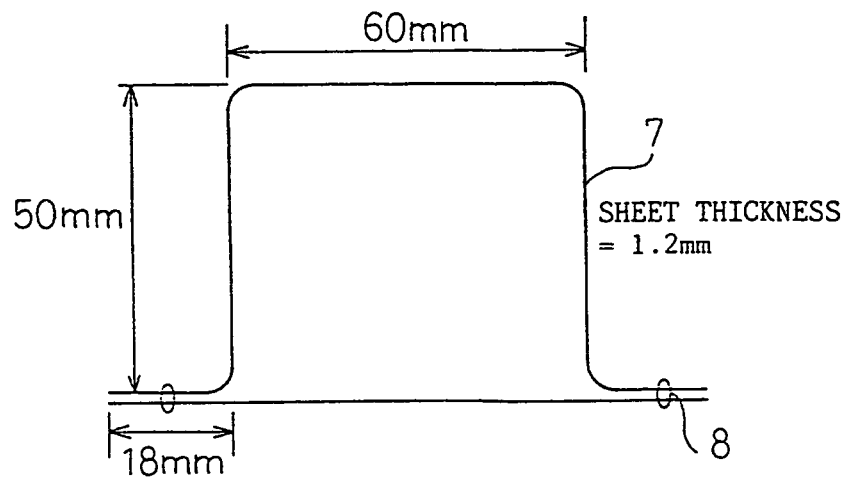

Fig. 7

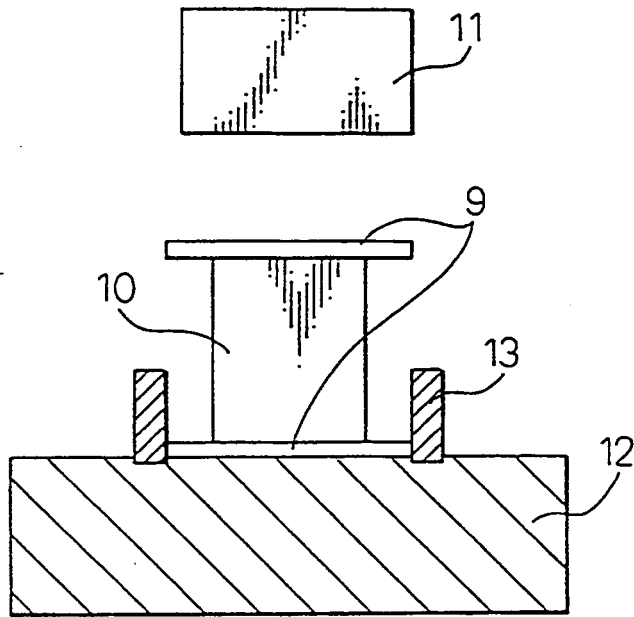

Fig. 8

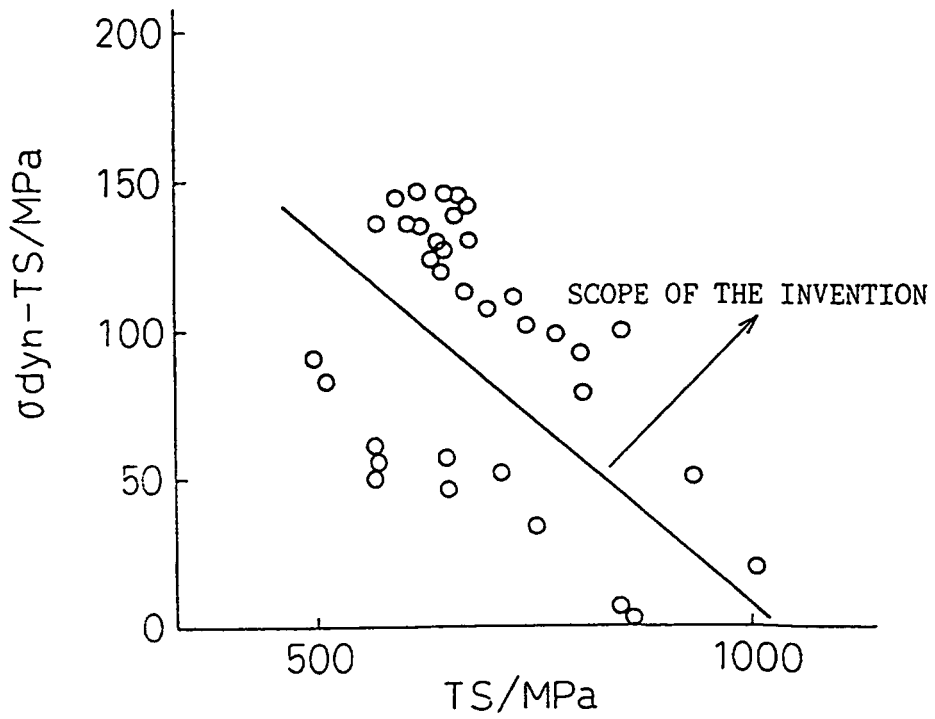

Fig.9

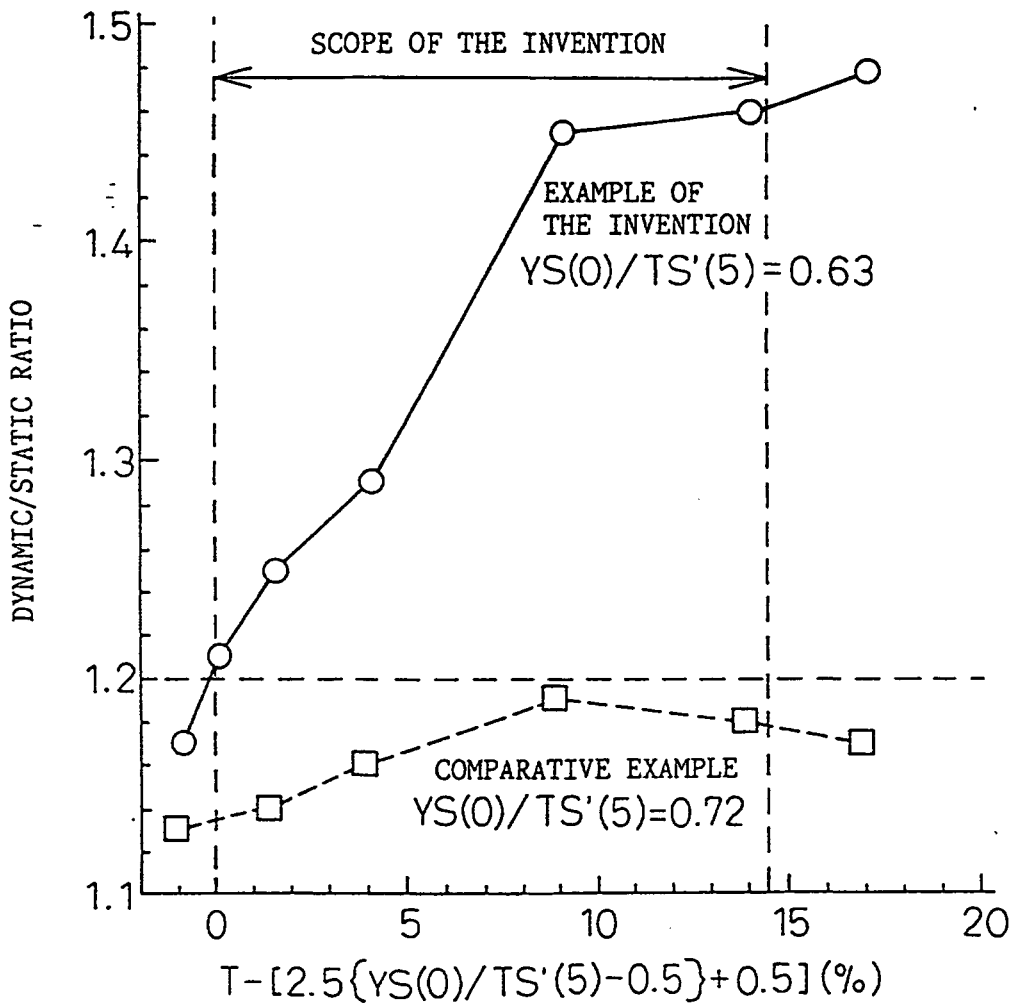

Fig.10

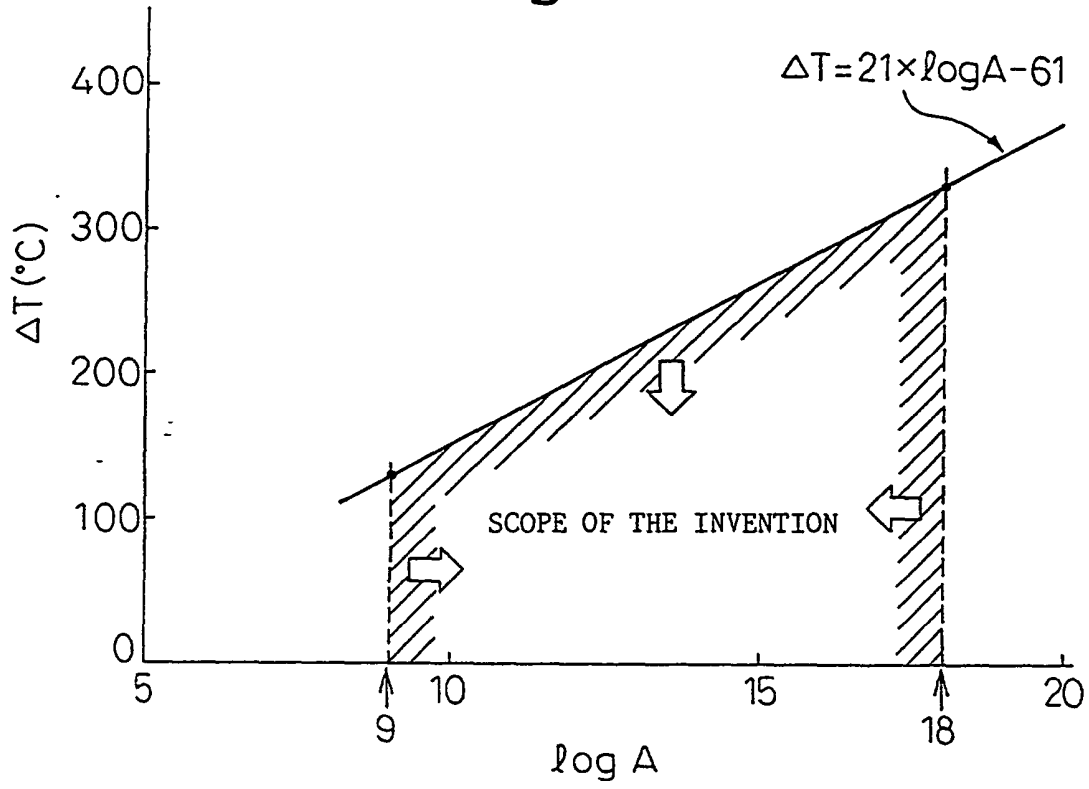

Fig.11

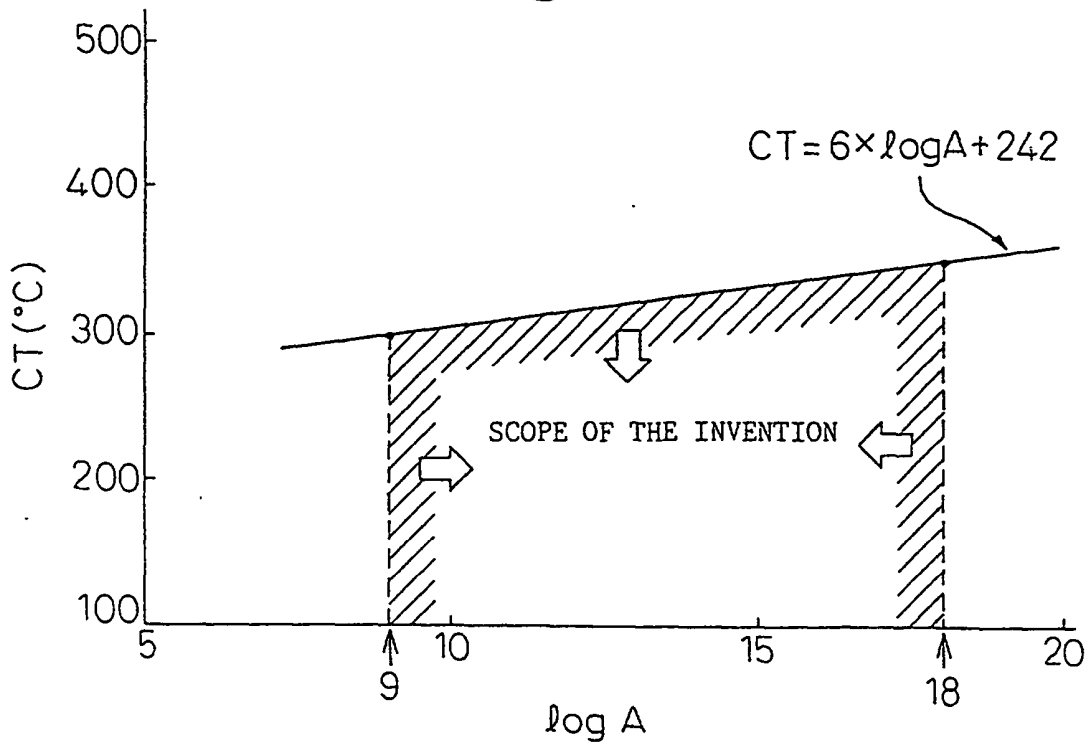
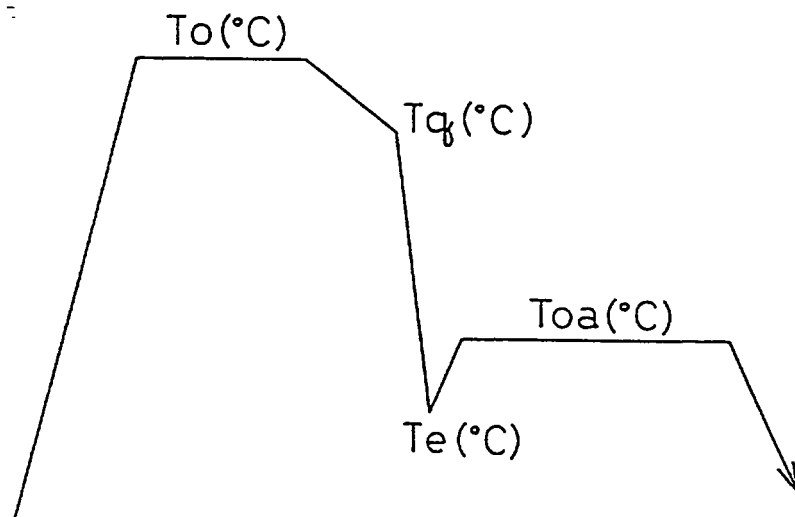

Fig.12



**REFERENCES CITED IN THE DESCRIPTION**

*This list of references cited by the applicant is for the reader's convenience only. It does not form part of the European patent document. Even though great care has been taken in compiling the references, errors or omissions cannot be excluded and the EPO disclaims all liability in this regard.*

**Patent documents cited in the description**

- JP 7018372 A [0003]
- JP 8098000 A [0004]
- JP 2287050 A [0004]
- JP 8109224 A [0004]
- JP 10291016 A [0004]
- JP 7090482 A [0007]
- EP 0719868 A [0008]
- JP 59219473 A [0061]

**Non-patent literature cited in the description**

- *CAMP-ISIJ*, vol. 9, 1112-1115 [0004]