

(12) STANDARD PATENT
(19) AUSTRALIAN PATENT OFFICE

(11) Application No. **AU 2016324552 B2**

(54) Title
Vacuum cleaner and method of controlling same

(51) International Patent Classification(s)
A47L 9/28 (2006.01) **A47L 9/32** (2006.01)
A47L 9/00 (2006.01)

(21) Application No: **2016324552** (22) Date of Filing: **2016.09.12**

(87) WIPO No: **WO17/048032**

(30) Priority Data

(31) Number	(32) Date	(33) Country
10-2015-0129472	2015.09.14	KR

(43) Publication Date: **2017.03.23**

(44) Accepted Journal Date: **2019.01.24**

(71) Applicant(s)
LG Electronics Inc.

(72) Inventor(s)
Ha, Gunho

(74) Agent / Attorney
Davies Collison Cave Pty Ltd, Level 14 255 Elizabeth Street, Sydney, NSW, 2000, AU

(56) Related Art
US 8,613,125 B2
KR 10-0756717 B1

(12) 특허협력조약에 의하여 공개된 국제출원

(19) 세계지식재산권기구
국제사무국

(43) 국제공개일
2017년 3월 23일 (23.03.2017)



(10) 국제공개번호
WO 2017/048032 A1

- (51) 국제특허분류: A47L 9/28 (2006.01) A47L 9/00 (2006.01)
A47L 9/32 (2006.01)
- (21) 국제출원번호: PCT/KR2016/010301
- (22) 국제출원일: 2016년 9월 12일 (12.09.2016)
- (25) 출원언어: 한국어
- (26) 공개언어: 한국어
- (30) 우선권정보: 10-2015-0129472 2015년 9월 14일 (14.09.2015) KR
- (71) 출원인: 엘지전자 주식회사 (LG ELECTRONICS INC.) [KR/KR]; 07336 서울시 영등포구 여의대로 128, Seoul (KR).
- (72) 발명자: 하건호 (HA, Gunho); 08592 서울시 금천구 가산디지털1로 51 LG 전자 특허센터, Seoul (KR).
- (74) 대리인: 김기문 (KIM, Ki Moon); 06252 서울시 강남구 역삼로 114 현죽빌딩 6층, Seoul (KR).
- (81) 지정국 (별도의 표시가 없는 한, 가능한 모든 종류의 국내 권리의 보호를 위하여): AE, AG, AL, AM, AO, AT, AU, AZ, BA, BB, BG, BH, BN, BR, BW, BY, BZ,

CA, CH, CL, CN, CO, CR, CU, CZ, DE, DK, DM, DO, DZ, EC, EE, EG, ES, FI, GB, GD, GE, GH, GM, GT, HN, HR, HU, ID, IL, IN, IR, IS, JP, KE, KG, KN, KP, KW, KZ, LA, LC, LK, LR, LS, LU, LY, MA, MD, ME, MG, MK, MN, MW, MX, MY, MZ, NA, NG, NI, NO, NZ, OM, PA, PE, PG, PH, PL, PT, QA, RO, RS, RU, RW, SA, SC, SD, SE, SG, SK, SL, SM, ST, SV, SY, TH, TJ, TM, TN, TR, TT, TZ, UA, UG, US, UZ, VC, VN, ZA, ZM, ZW.

- (84) 지정국 (별도의 표시가 없는 한, 가능한 모든 종류의 역내 권리의 보호를 위하여): ARIPO (BW, GH, GM, KE, LR, LS, MW, MZ, NA, RW, SD, SL, ST, SZ, TZ, UG, ZM, ZW), 유라시아 (AM, AZ, BY, KG, KZ, RU, TJ, TM), 유럽 (AL, AT, BE, BG, CH, CY, CZ, DE, DK, EE, ES, FI, FR, GB, GR, HR, HU, IE, IS, IT, LT, LU, LV, MC, MK, MT, NL, NO, PL, PT, RO, RS, SE, SI, SK, SM, TR), OAPI (BF, BJ, CF, CG, CI, CM, GA, GN, GQ, GW, KM, ML, MR, NE, SN, TD, TG).

공개:

- 국제조사보고서와 함께 (조약 제 21 조(3))
- 청구범위 보정 기한 만료 전의 공개이며, 보정서를 접수하는 경우 그에 관하여 별도 공개함 (규칙 48.2(h))

WO 2017/048032 A1

(54) Title: VACUUM CLEANER AND METHOD OF CONTROLLING SAME

(54) 발명의 명칭 : 진공 청소기 및 그의 제어방법

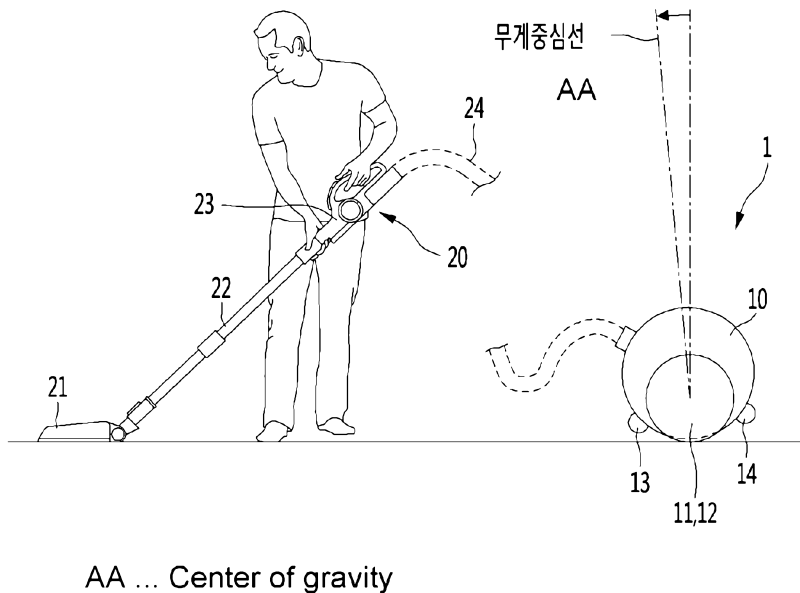

(57) Abstract: A vacuum cleaner of the present invention comprises: a cleaner body; a suctioning device communicating with the cleaner body; a wheel capable of moving the cleaner body; a motor for driving the wheel; a sensor for sensing the rotation angle of the cleaner body with respect to the center of rotation of the wheel; a memory in which a plurality of reference values for the sensor are stored; and a controller for deciding on one reference value from among the plurality of reference values and controlling the motor according to the size of an angle value sensed by the sensor, on the basis of the decided reference value.

(57) 요약서: 본 발명의 진공 청소기는, 청소기 본체; 상기 청소기 본체와 연통되는 흡입 장치; 상기 청소기 본체를 이동시킬 수 있는 휠; 상기 휠을 구동시키기 위한 모터; 상기 휠의 회전 중심에 대한 상기 청소기 본체의 회전 각도를 감지하기 위한 센서; 상기 센서에 대한 복수의 기준값이 저장되는 메모리; 및 상기 복수의 기준값 중 일 기준값을 결정하고, 결정된 기준값을 기초로 상기 센서에서 감지된 각도 값의

크기에 따라서 상기 모터를 제어하는 제어부를 포함한다.

【DESCRIPTION】**【Invention Title】**

Vacuum cleaner and method of controlling the same

【Technical Field】

A vacuum cleaner and method of controlling the same are disclosed herein.

【Background Art】

Generally, a vacuum cleaner is an apparatus which suctions air including dust by using a vacuum pressure generated by a suction motor installed inside a main body, and filters the dust in the main body.

The vacuum cleaner may be classified into a canister type in which a suction portion for sucking the air including the dust is provided separately with the main body and connected by a connecting pipe, and an up-right type in which a suction device is directly connected to the main body.

And, in the case of the canister type vacuum cleaner, cleaning may be performed as the suction portion is moved forward and backward or left and right while the main body is stopped, and in the case of the up-right type vacuum cleaner, cleaning may be performed as the main body and the suction portion are moved at the same time.

Of course, in the case of the canister type, when the suction portion is spaced apart from the main body, the main body may be moved by a force through which a user pulls the main body.

In Korean Patent Publication No. 10-1012953 (published on Jan 27, 2011), there is disclosed a vacuum cleaner which may move a main body automatically.

The vacuum cleaner of the prior art may include a main body; a main wheel for moving the main body; a driving motor for driving the main wheel; a detecting portion for detecting a rotation of the main body; and a controller controlling an operation of the driving motor by comparing a detecting value detected from the detecting portion and a determined reference value.

And, in order to prevent an abnormal motion of the main body about an error of the detecting portion, a step determining the reference value is performed when power is supplied to the main body.

In the case of the prior art, as an average value of an angle value while the main body is rotated in one direction and an angle value while the main body is rotated in the other direction is determined as the reference value, the reference value is always constant, and thus the error of the detecting portion may be reduced.

However, a position of weight center of the main body is varied according to a height

of the user, flooring material, distribution on cleaner production, and dust quantity in the cleaner, but in the case of the prior art, since the reference value is constant, there is an disadvantage that the main body may not perform an optimal driving.

For example, in the case of a tall person, cleaning is performed while the main body is tilted slightly backward, and in the case of a short person, cleaning is performed while the main body is titled slightly forward, but when the reference value is constant, there may be a problem that the main body is unintentionally moved forward or backward depending on the height of the user.

【Disclosure】

【Technical Problem】

The present invention is directed to providing a vacuum cleaner which may be moved automatically by following a user, and method of controlling the same.

The present invention is also directed to providing a vacuum cleaner which may perform an optimum driving performance as determining a reference in response to changes in a weight center of a cleaner main body.

【Technical Solution】

One aspect of the present invention provides a vacuum cleaner including a cleaner

main body; a suction device communicated with the cleaner main body; a wheel which may move the cleaner main body; a motor for driving the wheel; a sensor to detect a rotation angle of the cleaner main body about a rotation center of the wheel; a memory in which a plurality of reference values about the sensor are stored; and a controller which determines one reference value of the plurality of reference values and controls the motor depending on a size of an angle value detected from the sensor based on the determined reference value, wherein the controller determines any one of the plurality reference values after operating the motor about each of the plurality of reference values.

For determining one reference value of the plurality of reference values, the controller may rotate the motor at a reference angle in a second direction which is opposite to a first direction after rotating the motor at the reference angle in the first direction.

A current detecting portion for detecting a current of the motor may be further included, and the current may be detected from the current detecting portion whenever the motor is operated about each of the reference values, and the controller may determine a reference value having a minimum current value among the current values detected from the current detecting portion.

The sensor may be one of an angle sensor, an acceleration sensor and a gyro sensor.

The controller may determine any one reference value of the plurality of reference

values whenever the cleaner main body starts to be operated.

In the case in which the angle value detected from the sensor departs from a range of forward and backward angle value, the controller may control the motor so that the cleaner main body moves forward or backward.

The forward angle value or the backward angle value may be varied depending on the reference value.

An auxiliary wheel for a movement of the cleaner main body may be further included, and when the angle value detected from the sensor is within the range of the forward and backward angle value, the auxiliary wheel may be spaced apart from the bottom.

Another aspect of the present invention provides a vacuum cleaner including a cleaner main body; a suction device communicated with the cleaner main body; a wheel which may move the cleaner main body; a motor to drive the wheel; a sensor to detect a value changed depending on a movement of a detection target about a rotation center of the wheel; and a controller which determines one reference value of a plurality of reference values, each of the reference values being associated with a respective starting position for the detection target, and controls the motor according to a relative movement of the detection target based on the movement of the detection target detected by the sensor from the starting position associated with determined reference value,

wherein the controller determines the one reference value of the plurality of reference values after operating the motor to position the detection target about each of the starting positions associated with the plurality of reference values, wherein in the case in which the detecting value exceeds a forward reference value, the controller controls the motor so that the cleaner main body moves forward, and in the case in which the detecting value exceeds a backward reference value, the controller controls the motor so that the cleaner main body moves backward.

Also another aspect of the present invention provides a method of controlling the vacuum cleaner including inputting a start command of a cleaner main body; detecting, by a sensor provided in the cleaner main body, a value changed along a movement of a detection target; and controlling a motor to rotate a wheel of the cleaner main body according to a detected value detected from the sensor,

wherein a controller determines one reference value of a plurality of reference values, each of the reference values being associated with a respective starting position for the detection target, and controls the motor according to a relative movement of the detection target based on the movement of the detection target detected by the sensor from the starting position associated with determined reference value,

wherein the controller determines the one reference value of the plurality of reference values after operating the motor to position the detection target about each of the starting

positions associated with the plurality of reference values,

wherein in the case in which the detecting value exceeds the forward reference value, the controller controls the motor so that the cleaner main body moves forward, and in the case in which the detecting value exceeds a backward reference value, the controller may control the motor so that the cleaner main body moves backward.

The detection target may be the cleaner main body.

The detecting value may be a rotation angle of the cleaner main body about a rotation center of the wheel.

The sensor may be one of an angle sensor, an acceleration sensor and a gyro sensor.

When the detecting value is equal to or less than the forward reference value while the cleaner main body moves forward, the controller may stop the motor.

When the detecting value is equal to or less than the backward reference value while the cleaner main body moves backward, the controller may stop the motor.

In the case in which the detecting value detected from the sensor is within a range of the forward reference value and the backward reference value while the motor is stopped, the controller may maintain a state in which the motor is stopped.

【Advantageous Effects】

According to the proposed invention, as the cleaner main body is moved automatically in the cleaning process by a detection of tilt of the cleaner main body, a distance between the user and the cleaner main body may be maintained in a certain distance.

Therefore, since the user does not need to move the cleaner main body directly, there is an advantage that a cleaning convenience of the user is improved.

Also, since one reference value of the plurality of reference values is decided whenever the cleaning is performed based on a position of a weight center line of the cleaner main body, and whether the movement of the cleaner main body is determined based on the determined reference value, an abnormal motion of the main body may be prevented.

【Description of Drawings】

FIG. 1 is a view illustrating a vacuum cleaner when a first user performs a cleaning;

FIG. 2 is a view illustrating the vacuum cleaner when a second user performs the cleaning;

FIG. 3 is a block diagram of the vacuum cleaner according to an embodiment of the present invention;

FIG. 4 is a flow diagram illustrating a method for determining a reference value of an angle sensor of the vacuum cleaner;

FIG. 5 is a flow diagram illustrating a control method of a motor for determining the reference value of the angle sensor;

FIG. 6 is a view illustrating a plurality of reference values which may be determined; and

FIG. 7 is a view illustrating a using state of the vacuum cleaner of the present invention.

【Mode for Invention】

Hereinafter, exemplary embodiments of the present disclosure will be described with reference to the accompanying drawings. Regarding the reference numerals assigned to the elements in the drawings, it should be noted that the same elements may be designated by the same reference numerals, wherever possible, even though they are shown in different drawings.

Also, in the description of embodiments, terms such as first, second, A, B, (a), (b) or the like may be used herein when describing components of the present invention. Each of these terminologies is not used to define an essence, order or sequence of a corresponding component but used merely to distinguish the corresponding component from other component(s). It should be noted that if it is described in the specification that one component is “connected,” “coupled” or “joined” to another component, the former may be

directly “connected,” “coupled” or “joined” to the latter or “connected,” “coupled” or “joined” to the latter via another component.

FIG. 1 is a view illustrating a vacuum cleaner when a first user performs a cleaning, FIG. 2 is a view illustrating the vacuum cleaner when a second user performs the cleaning, and FIG. 3 is a block diagram of the vacuum cleaner according to an embodiment of the present invention.

Referring to FIGS. 1 to 3, a vacuum cleaner 1 according to an embodiment of the present invention may include a cleaner main body 10 having a suction motor 32.

Also, the vacuum cleaner 1 may include one or more main wheels 11 and 12 for a movement of the cleaner main body 10. The vacuum cleaner 1 may include a plurality of main wheels 11 and 12 so as to move stably.

The plurality of main wheels 11 and 12 may include a first wheel 11 and a second wheel 12.

The cleaner main body 10 may be rotated about a rotation center of the plurality of main wheels 11 and 12. That is, the rotation center of the plurality of main wheels 11 and 12 may be matched with a rotation center of the cleaner main body 10.

A weight center of the cleaner main body 10 may be positioned higher than the rotation center of the plurality of main wheels 11 and 12, but is not limited thereto. In this

case, the cleaner main body 10 is in an unstable state and the rotation of the cleaner main body 10 with respect to the rotation center may be performed smoothly.

While the cleaner main body 10 is rotated, the vacuum cleaner 1 may further include a plurality of auxiliary wheels 13 and 14 helping the movement of the cleaner main body 10.

In the present invention, when the cleaner main body 10 is rotated in a counterclockwise direction based on the FIG. 1, that is defined to be rotated in a front direction (a first direction), and when rotated in a clockwise direction, that is defined to be rotated in a rear direction (a second direction).

The plurality of auxiliary wheels 13 and 14 may include a first auxiliary wheel 13 which may be in contact with a bottom surface when the cleaner main body 10 is rotated in the front direction and a second auxiliary wheel 14 which may be in contact with the bottom surface when the cleaner main body 10 is rotated in the rear direction.

According to the rotation angle of the cleaner main body 10, the cleaner main body 10 and the plurality of auxiliary wheels 13 and 14 may be spaced apart from the bottom surface.

The vacuum cleaner 1 may further include a plurality of motors 33 and 34 driving each of the plurality of main wheels 11 and 12.

The motors 33 and 34 may be controlled to maintain a state in which the cleaner main body 10 and the plurality of auxiliary wheels 13 and 14 are spaced apart from the bottom

surface.

At this time, a state in which the plurality of auxiliary wheels 13 and 14 are not in contact with the bottom surface may be a self-supporting state of the cleaner main body 10.

The plurality of motors 33 and 34 may include a first motor 33 connected to the first wheel 11 and a second motor 34 connected to the second wheel 12.

Each of the motors 33 and 34 may operate independently. Therefore, the cleaner main body 10 may not only move forward and backward, but also turn left or right.

The vacuum cleaner 1 may further include a suction device 20 guiding air including dust to the cleaner main body 10.

The suction device 20 may include a suction portion 21 for sucking dust of a cleaning surface, in one example the bottom surface, and connecting portions 22, 23, and 24 for connecting the suction portion 21 to the cleaner main body 10.

The connecting portions 22, 23 and 24 may include an extension tube 22 connected to the suction portion 21, a handle 23 connected to the extension tube 22, and a suction hose 24 connecting the handle 23 to the cleaner main body 10.

The vacuum cleaner 1 may further include an angle sensor 35 for detecting the rotation angle of the cleaner main body 10, and a controller 30 controlling the plurality of motors 33 and 34 based on the angle detected from the angle sensor 35.

As shown in FIG. 1, in the case in which a first user uses the vacuum cleaner 1, the weight center line connecting the rotation center and the weight center may be inclined by a certain angle forward based on a vertical line. In this state, the cleaner main body 10 may maintain the self-supporting state without the operation of the motors 33 and 34.

As shown in FIG. 2, in the case in which a second user who is taller than the first user uses the vacuum cleaner 1, the weight center line may be inclined by a certain angle backward based on the vertical line. In this state, the cleaner main body 10 may maintain the self-supporting state without the operation of the motors 33 and 34.

And, in the state as shown in FIG. 1, in the case in which a clockwise rotation angle of the cleaner main body 10 is increased by a first angle, the motors 33 and 34 should be operated for the self-supporting of the cleaner main body 10, but in the state as shown in FIG. 2, even if the clockwise rotation angle of the cleaner main body 10 is increased by the first angle, it may maintain the self-supporting state without the operation of the motors 33 and 34.

Like this, in one example, according to the user's height, a relative position of the weight center line about the vertical line may be changed, and the optimum driving of the cleaner main body 10 is possible by operating the motors 33 and 34 to reflect the position of this weight center line.

In the present invention, according to the weight center line, a reference value of the

angle sensor 35 may be varied.

A plurality of reference values of the angle sensor 35 are set, and according to the weight center line, any one reference value of the plurality of reference values may be determined.

For determining the reference value of the angle sensor 35, the vacuum cleaner 1 may further include a current detecting portion 36 detecting a current of each of the motors 33 and 34.

The vacuum cleaner 1 may further include a memory 37 in which the plurality of reference values are stored. In the memory 37, the reference value determined according to the weight center line may be stored additionally.

Hereinafter, a process of determining the reference value of the angle sensor 35 will be described.

FIG. 4 is a flow diagram illustrating a method for determining a reference value of an angle sensor of the vacuum cleaner, FIG. 5 is a flow diagram illustrating a control method of a motor for determining the reference value of the angle sensor, and FIG. 6 is a view illustrating a plurality of reference values which may be determined.

Referring to FIGS. 4 to 6, a starting command of the vacuum cleaner 1 is input (S1).

When the starting command of the vacuum cleaner 1 is input, the controller 30 drives

the motors 33 and 34 about each of the plurality of reference values stored in the memory 37 and detects the current (S2).

Specifically, as shown in FIG. 6, in one example, five reference values are pre-set, and first, respect to a first reference value, the motors 33 and 34 are rotated at the reference angle in the first direction (S21). In a rotation process of the motors 33 and 34, the current is detected from the current detecting portion 36 (S22), and the detected current is stored in the memory 37.

And, the motors 33 and 34 are rotated at the reference angle in the second direction (S23). And, in the rotation process of the motors 33 and 34, the current is detected from the current detecting portion 36 (S24), and the detected current is stored in the memory 37.

After the completion of the current detection about the first reference value, the current detection of a second reference value is performed. In such a method, the current detection of the first reference value to a fifth reference value is performed.

And, a minimum current is determined by comparing the detected current value of each of the reference values (S3). And, a reference value having the minimum current is determined, and the determined reference value is stored (S4).

According to the position of the weight center line of the cleaner main body 10, when each of the motors 33 and 34 is driven in the first and second direction at the reference angle,

the current detected from the current detecting portion 36 is different, and in the present embodiment, the minimum current detected from the current detecting portion 36 determines the reference value.

For example, as shown in FIG. 1 when the weight center line is positioned, the reference value having the minimum current detected from the current detecting portion 36 may be the second reference value in the FIG. 6.

On the other hand, as shown in FIG. 2 when the weight center line is positioned, the reference value having the minimum current detected from the current detecting portion 36 may be a fourth reference value in the FIG. 6.

Determination of such a reference value may be performed whenever an operation start command (or a cleaning start command) is input. That is, the reference value may be initialized whenever the cleaning operation is started.

FIG. 7 is a view illustrating a using state of the vacuum cleaner of the present invention.

In the FIG. 7, (a) shows a state in which the cleaner main body 10 is self-supported, (b) shows a state in which the cleaner main body 10 is rotated more than the forward angle value in the front direction and then moves forward, and (c) shows a state in which the cleaner main body 10 is rotated more than the backward angle value in the rear direction and then moves

backward.

Referring to FIGS. 1 to 7, the operation start command is input, and the reference value is determined. Then, the user moves the suction portion 21 forward and backward in the cleaning performing process, and correspondingly, the cleaner main body 10 is inclined to the front or rear side.

Then, in the angle sensor 35, the rotation angle of the cleaner main body 10 is detected, and the controller 30 compares the angle value detected from the angle sensor 35 and a reference angle value. At this time, the reference angle value may include the forward angle value and the backward angle value.

In one example, in the case in which the angle value detected from the angle sensor 35 is within the range of the forward angle value and the backward angle value, the controller 30 maintains a state in which the motors 33 and 34 are stopped.

On the other hand, in the case in which the angle value detected from the angle sensor 35 departs from the range of the forward angle value and the backward angle value, the controller 30 may control the motors 33 and 34 so that the cleaner main body 10 moves forward or backward.

For example, like (b) of FIG. 7, when the angle value detected from the angle sensor 35 exceeds the forward angle value, the controller 30 may control the motors 33 and 34 so

that the cleaner main body 10 moves forward.

When the motors 33 and 34 are operated, an absolute value of the angle value detected from the angle sensor 35 becomes smaller, and thus the cleaner main body 10 is in a state like (a) of FIG. 7.

When the angle value detected from the angle sensor 35 is within the range of the forward angle value and the backward angle value while the motors 33 and 34 are operated, the controller 30 stops the operation of the motors 33 and 34.

On the other hand, like (c) of FIG. 7, when the angle value detected from the angle sensor 35 exceeds the backward angle value, the controller 30 may control the motors 33 and 34 so that the cleaner main body 10 moves backward.

When the motors 33 and 34 are operated, the absolute value of the angle value detected from the angle sensor 35 becomes smaller, and thus the cleaner main body 10 is in the state like (a) of FIG. 7.

When the angle value detected from the angle sensor 35 is within the range of the backward angle value and the forward angle value while the motors 33 and 34 are operated, the controller 30 stops the operation of the motors 33 and 34.

That is, according to the present invention, in the process that the cleaner main body 10 moves forward or backward and self-supported by the control of the motors 33 and 34, the

distance between the user and the cleaner main body 10 may be maintained within a certain range.

Here, the reference value is not limited but is an angle value and may be set in a form such as 0, 1, 2, (-)1, (-)2.

For example, when the first reference value is 0, the forward angle value for moving the cleaner main body 10 forward is 3, and the backward angle value may be (-)3.

On the other hand, when the second reference value is 1, the forward angle value for moving the cleaner main body 10 forward is 4, and the backward angle value may be (-)2.

Therefore, in the case in which the angle value detected from the angle sensor 35 is 3 while the first reference value is selected, the cleaner main body 10 moves forward, but in the case in which the angle value detected from the angle sensor 35 is 3 while the second reference value is selected, the cleaner main body 10 maintains a suspended state.

Therefore, the forward angle value and the backward angle value are set differently depending on the reference value.

According to the present invention, as the cleaner main body 10 is moved automatically in the cleaning process by the detection of tilt of the cleaner main body 10, the distance between the user and the cleaner main body 10 may be maintained in a certain distance. Therefore, since the user does not need to move the cleaner main body 10 directly,

there is an advantage that the cleaning convenience of the user is improved.

Also, since one reference of the plurality of references is determined whenever the cleaning is performed based on the position of the weight center line of the cleaner main body 10, an abnormal motion of the cleaner main body 10 may be prevented.

In the above embodiment, although it is described that the operation of the motors 33 and 34 are controlled based on the angle sensor 35, in contrast, the operation of the motors 33 and 34 may also be controlled by using an acceleration sensor or a gyro sensor. Also in this case, a plurality of reference values about the acceleration sensor or the gyro sensor are stored, and any one of the plurality of reference values may be determined at every cleaning start time.

Although the embodiments have been described with reference to a number of illustrative embodiments thereof, it should be understood that numerous other modifications and embodiments can be devised by those skilled in the art that will fall within the spirit and scope of the principles of this disclosure. The embodiments disclosed herein, therefore, are not to be taken in a sense for limiting the technical concept of the present invention but for explanation thereof, and the range of the technical concept is not limited to these embodiments.

Throughout this specification and the claims which follow, unless the context requires otherwise, the word "comprise", and variations such as "comprises" or "comprising", will be understood to imply the inclusion of a stated integer or step or group of integers or steps but not the exclusion of any other integer or step or group of integers or steps.

The reference in this specification to any prior publication (or information derived from it), or to any matter which is known, is not, and should not be taken as, an acknowledgement or admission or any form of suggestion that that prior publication (or information derived from it) or known matter forms part of the common general knowledge in the field of endeavour to which this specification relates.

The claims defining the invention are as follows:

1. A vacuum cleaner comprising:

a cleaner main body;

a suction device communicated with the cleaner main body;

a wheel which may move the cleaner main body;

a motor for driving the wheel;

a sensor to detect a rotation angle of the cleaner main body about a rotation center of the wheel;

a memory in which a plurality of reference values about the sensor are stored; and

a controller which determines one reference value of the plurality of reference values and controls the motor depending on a size of an angle value detected from the sensor based on the determined reference value;

wherein the controller determines any one of the plurality of reference values after operating the motor about each of the plurality of reference values.

2. The vacuum cleaner of claim 1, wherein, for determining the one reference value of the plurality of reference values, the controller rotates the motor at a reference angle in a second direction which is opposite to a first direction after rotating the motor at the reference angle in the first direction.

3. The vacuum cleaner of claim 2, further comprising a current detecting portion for detecting a current of the motor,

wherein, whenever the motor is operated with respect to each of the reference values, the current is detected from the current detecting portion, and

the controller determines a reference value having a minimum current value of the current values detected from the current detecting portion.

4. The vacuum cleaner of any one of the preceding claims, wherein the sensor is one of an angle sensor, an acceleration sensor and a gyro sensor.

5. The vacuum cleaner of any one of the preceding claims, wherein the controller determines one reference value of the plurality of reference values whenever the cleaner main body starts to be operated.

6. The vacuum cleaner of claim 1, wherein in the case in which the angle value detected from the sensor departs from a range of a forward angle value and a backward angle value, the controller controls the motor so that the cleaner main body moves forward or backward.

7. The vacuum cleaner of claim 6, wherein the forward angle value or the backward angle value is varied depending on the reference value.

8. The vacuum cleaner of any one of claims 6 or 7, further comprising an auxiliary

wheel for a movement of the cleaner main body,

wherein when the angle value detected from the sensor is within the range of the forward angle value and the backward angle value, the auxiliary wheel is spaced apart from a bottom.

9. A vacuum cleaner comprising:

a cleaner main body;

a suction device communicated with the cleaner main body;

a wheel which may move the cleaner main body;

a motor to drive the wheel;

a sensor to detect a value changed depending a movement of a detection target about a rotation center of the wheel; and

a controller which determines one reference value of a plurality of reference values, each of the reference values being associated with a respective starting position for the detection target, and controls the motor according to a relative movement of the detection target based on the movement of the detection target detected by the sensor from the starting position associated with determined reference value,

wherein the controller determines the one reference value of the plurality of reference values after operating the motor to position the detection target about each of the starting

positions associated with the plurality of reference values, and

wherein in the case in which the detecting value exceeds a forward reference value, the controller controls the motor so that the cleaner main body moves forward, and in the case in which the detecting value exceeds a backward reference value, the controller controls the motor so that the cleaner main body moves backward.

10. A method of controlling a vacuum cleaner comprising:

inputting a start command of a cleaner main body;

detecting, by a sensor provided in the cleaner main body, a value changed along a movement of a detection target; and

controlling a motor to rotate a wheel of the cleaner main body according to a detected value detected from the sensor,

wherein a controller determines one reference value of a plurality of reference values, each of the reference values being associated with a respective starting position for the detection target, and controls the motor according to a relative movement of the detection target based on the movement of the detection target detected by the sensor from the starting position associated with determined reference value,

wherein the controller determines the one reference value of the plurality of reference values after operating the motor to position the detection target about each of the starting

positions associated with the plurality of reference values, and

wherein in the case in which the detecting value exceeds a forward reference value, the controller controls the motor so that the cleaner main body moves forward, and in the case in which the detecting value exceeds a backward reference value, the controller controls the motor so that the cleaner main body moves backward.

11. The method of claim 10, wherein the detection target is the cleaner main body.

12. The method of claim 11, wherein the detecting value is a rotation angle of the cleaner main body about a rotation center of the wheel.

13. The method of claim 10, wherein when the detecting value is equal to or less than the forward reference value while the cleaner main body moves forward, the controller stops the motor.

14. The method of claim 10, wherein when the detecting value is equal to or less than the backward reference value while the cleaner main body moves backward, the controller stops the motor.

【DRAWINGS】

【Figure 1】

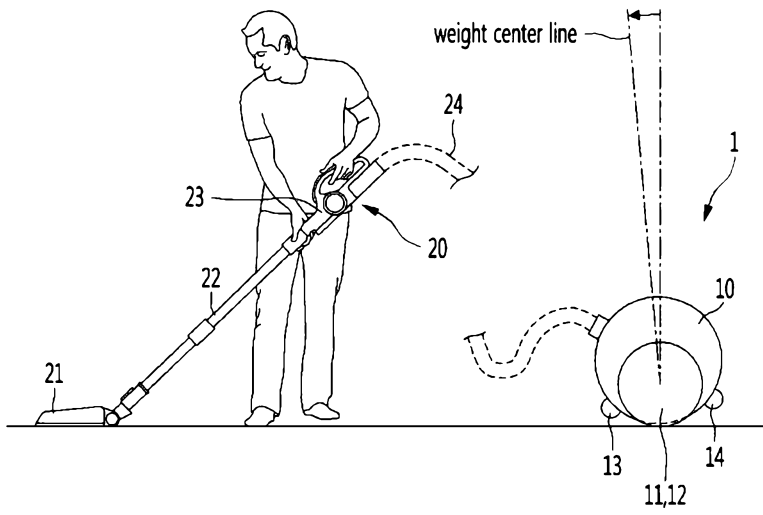

【Figure 2】

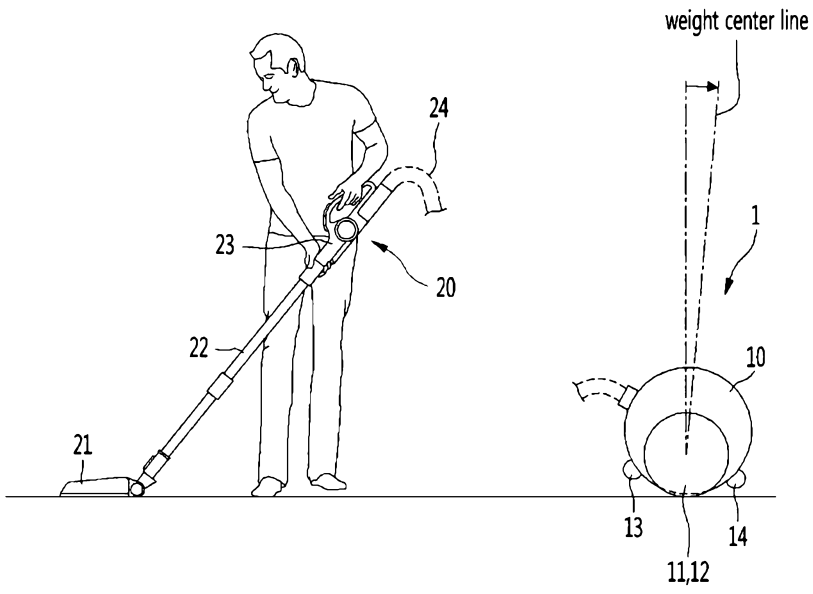

【Figure 3】

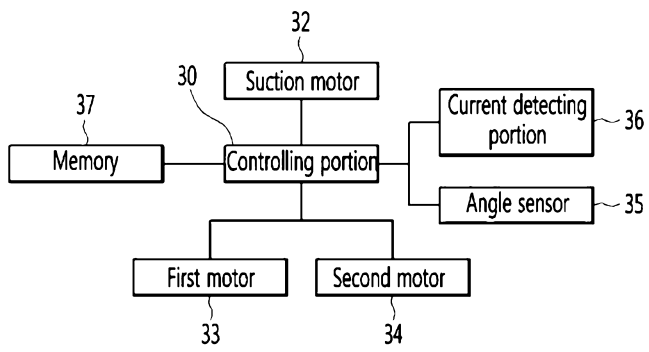

【Figure 4】

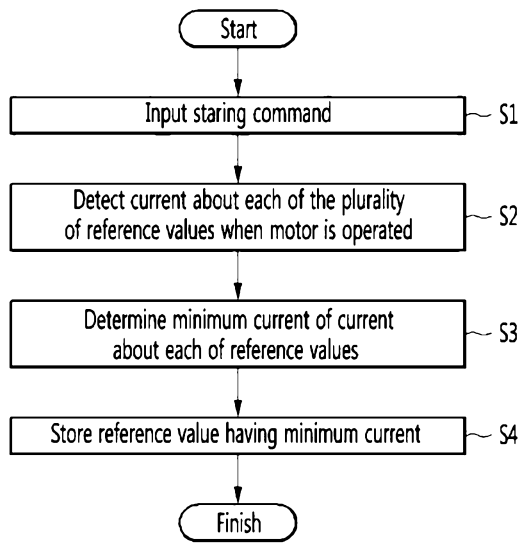

【Figure 5】

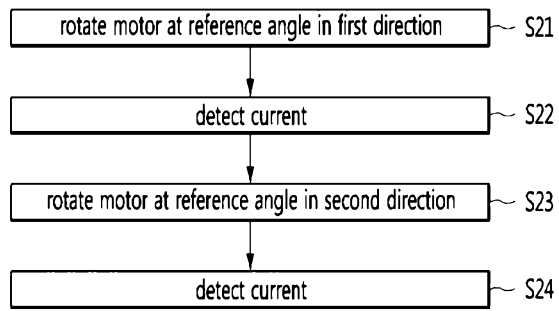

【Figure 6】

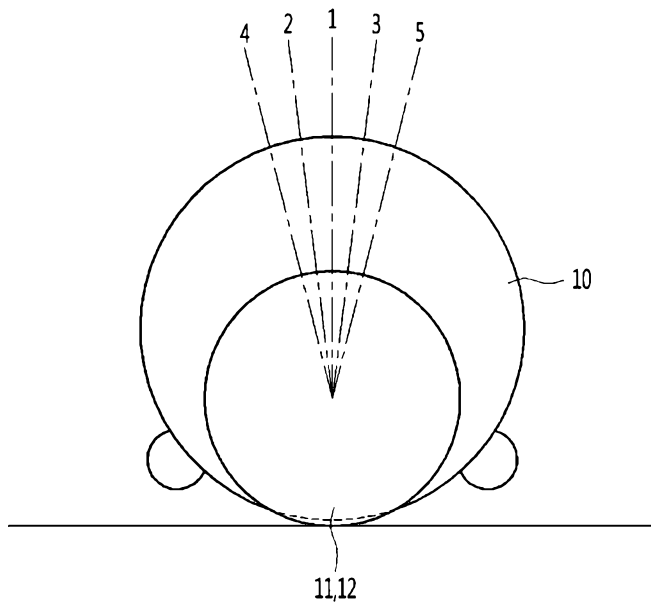

【Figure 7】

