



(11) **EP 1 930 601 A2**

(12) **EUROPEAN PATENT APPLICATION**

(43) Date of publication:
11.06.2008 Bulletin 2008/24

(51) Int Cl.:
F04D 29/42^(2006.01) F04D 29/62^(2006.01)

(21) Application number: **07121376.3**

(22) Date of filing: **23.11.2007**

(84) Designated Contracting States:
AT BE BG CH CY CZ DE DK EE ES FI FR GB GR HU IE IS IT LI LT LU LV MC MT NL PL PT RO SE SI SK TR
Designated Extension States:
AL BA HR MK RS

(72) Inventor: **Ranalli, Antonio,**
LN 2 S.r.l. a socio unico
66020 Scerni (CH) (IT)

(74) Representative: **Fabris, Stefano et al**
Cantaluppi & Partners S.r.l.
Via Matteotti 26
35137 Padova (IT)

(30) Priority: **06.12.2006 IT PD20060446**

(71) Applicant: **LN 2 S.R.L. a socio unico**
62010 Montecassiano (MC) (IT)

(54) **Fan casing for use in extractor hoods**

(57) There is described a scroll type manifold which is intended to constitute the housing of an impeller (2) of a fan, comprising a pair of half-shells (4, 5) which can be connected to each other in a connection plane (P), each half-shell (4, 5) including a respective portion (4a, 5a) of a delivery nozzle (6) of the manifold, the nozzle portions together defining the delivery cross-section (3) of the manifold. The manifold half-shells (4, 5) are articulated to each other about an articulation axis (Z), so as to be mutually pivotable between a first operating position, in which the half-shells (4, 5) are connected along the connection plane (P) and the nozzle portions (4a, 5a) delimit the entire delivery cross-section (3), and a second operating position, in which the nozzle portions (4a, 5a) are moved towards each other with a consequent reduction in the extent of the delivery cross-section (3).

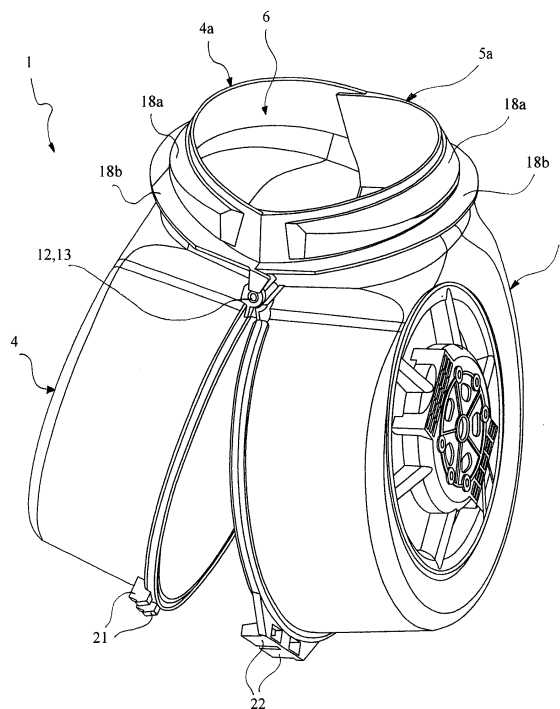

Fig. 2

Description

[0001] The present invention relates to a manifold, in particular a scroll type manifold which is intended to constitute the housing of the impeller of a fan, particularly for extractor hoods, having the features set out in the preamble of the main claim.

[0002] The invention is used particularly, though not exclusively, in the construction of ventilation units for hoods for extracting air-like gases from domestic environments.

[0003] In that context, the construction of scroll type manifolds in two separate half-shells which can be connected to each other is commonly used in the specific sector for construction of ventilation units for extractor hoods or similar devices for extracting fumes, vapours or other air-like gases.

[0004] In those applications, the manifold, also referred to using the term "cochlea", is typically constructed in two half-shells which can be connected to each other in a connection plane so as to construct the volute of the manifold, inside which the impeller is rotatably supported and actuated by the relevant motor unit.

[0005] The manifold is further generally fixed to the frame of the extractor hood so that the discharge pipe from the hood is connected to the delivery cross-section of the manifold. Typically, that delivery cross-section is constructed in the form of a substantially cylindrical nozzle which can be fitted, preferably in a fluid-tight manner, in the discharge pipe from the extractor hood. The manifold is normally rigidly fixed to the frame of the extractor hood with screw type means or other similar fixing means of the removable type, in order to facilitate the assembly/disassembly phases of the ventilation unit in installation locations and the subsequent maintenance operations.

[0006] In that regard, such applications normally involve limited accessibility to the ventilation unit, owing mainly to the small spaces provided internally with respect to the extractor hoods in the region for assembling the ventilation unit, which circumstance makes the operations for assembling/disassembling the ventilation unit complex and quite difficult, and in particular those necessary for assembling/disassembling the manifold on/from the frame of the extractor hood.

[0007] A main object of the invention is to overcome those limitations by means of a manifold which is configured in such a manner as to allow an operator readily and quickly to be able to connect or disconnect the manifold to/from the extractor hood structure to which it is fixed, and to gain access to the motor/impeller unit more readily and more quickly, with overall greater simplification of the assembly/disassembly operations.

[0008] This object and other objects which will be clearly appreciated below are achieved by a manifold, in particular a scroll type manifold constructed in accordance with the appended claims.

[0009] Other features and advantages of the invention will be appreciated more clearly from the following de-

tailed description of one preferred embodiment thereof, which is illustrated purely by way of non-limiting example with reference to the appended drawings, in which:

- 5 - Figure 1 is a perspective view of a scroll type manifold constructed in accordance with the present invention in a first operating position,
- Figure 2 is a perspective view of the manifold of the preceding Figure in a second different operating position,
- 10 - Figure 3 is a partial perspective view, drawn to an enlarged scale, of one of the half-shells with which the manifold of the preceding Figures is constructed,
- Figure 4 is a perspective view of the other of the half-shells of the manifold according to the invention,
- 15 - Figure 5 is a partial schematic view of the connection of the manifold according to the invention to a frame structure of an extractor hood,
- Figures 6 and 7 are schematic side elevations of the manifold according to the invention in two separate operating positions.
- 20

[0010] With reference to the Figures mentioned, a scroll type manifold generally designated 1 is constructed in accordance with the invention and provided so as to constitute the housing of a radial fan impeller 2, which is only schematically illustrated and which can be driven in rotation by a motor unit (not illustrated) about an axis of rotation designated X.

25 **[0011]** There is defined in the manifold 1 a delivery cross-section 3, in which the delivery flow direction which is indicated by the direction of the axis Y of the Figures, is directed substantially perpendicularly relative to the axis of rotation.

30 **[0012]** The manifold 1 comprises a first and a second manifold half-shell, which are designated 4 and 5, respectively, and which can be connected to each other in a connection plane P. The half-shells are preferably substantially configured in a specularly symmetrical manner with respect to the connection plane, the plane therefore defining a substantially symmetrical centre plane.

35 **[0013]** Each half-shell 4, 5 comprises a respective portion 4a, 5a of a delivery nozzle 6, the portions 4a, 5a together defining the delivery cross-section 3. The nozzle portions are advantageously configured so as to have a semi-cylindrical profile so as to define a delivery nozzle which has a circular cross-section and which is able to be connected, preferably in a fluid-tight manner, to a tubular discharge pipe, which is designated 7 and which is only schematically illustrated in the Figures, of an extractor hood structure 8 which is also only partially illustrated in the appended Figures. The pipe 7 is provided in order to convey the flow which is drawn in by the ventilation unit in the direction of the exhaust of the hood.

40 **[0014]** There is further provided in the half-shell 4 a main intake cross-section 9 of the fan comprising a lateral opening 9a which is advantageously of circular shape and which is coaxial with the axis of the impeller.

[0015] There is provided, in the other half-shell 5, in a position corresponding to the opposite opening 9a, a flange 10 for supporting the impeller/motor unit, which flange 10 is connected to the half-shell by means of a plurality of strut-like elements 11. The through-holes which are defined between the struts 11 and the central flange 10 are such that together they constitute another auxiliary intake cross-section with respect to the main cross-section 9. The motor/impeller unit can further be rotatably supported on the flange 10 in a manner projecting into the manifold.

[0016] According to a main feature of the invention, the half-shells 4, 5 of the manifold are connected to each other in an articulated manner about an articulation axis which is designated Z in the Figures. By means of this articulated connection, the half-shells 4, 5 can be mutually pivoted between a first position (Figure 1), in which they are connected along the connection plane P and the nozzle portions 4a, 5a delimit the entire delivery cross-section 3, and a second operating position (Figure 2), in which the nozzle portions are moved towards each other with a consequent reduction in the extent of the delivery cross-section, whose function will be clearly appreciated in the remainder of the description.

[0017] The articulation region preferably extends near the nozzle portions and the articulation axis Z of the half-shells is defined in the centre plane of symmetry of the manifold (perpendicular to the axis X of the impeller and substantially coincident with the connection plane P).

[0018] That articulation axis is further located in the region between the free end of the nozzle 6 and the axis X of the impeller.

[0019] There are provided, for the articulated connection of the half-shells, articulation means which comprise a pair of pin-like formations 12 which are provided on the half-shell 5, at diametrically opposed sides in the corresponding nozzle portion 5a, and a pair of respective eyelet-like formations 13 which are formed in the corresponding position on the other half-shell 4. Each eyelet-like formation 13 can be engaged in an articulated manner with a hinge-like connection by the corresponding pin-like formation 12, as clearly illustrated in Figures 3 and 4. The hinge-like connection is brought about along the axis of articulation Z.

[0020] Each half-shell 4, 5 further comprises retention means, which are generally designated 14 and which can cooperate with respective counter-retention means which are provided on a frame structure 15 of the hood 8, with which the manifold 1 is intended to be connected in a removable manner.

[0021] In greater detail, the retention means are provided on each nozzle portion 4a, 5a and comprise a respective groove 16 which can be engaged with a profile 17 of a projection of the frame 15, that projection constituting the corresponding counter-retention means. Each projection being engaged in the respective groove of the corresponding half-shell brings about, in the direction of the axis Y, axial retention of the manifold with respect to

the stationary structure of the frame of the hood 8, with the manifold in the first operating position.

[0022] Advantageously, each groove 16 extends in the external semi-cylindrical surface of the corresponding nozzle portion and is developed by a main portion of the semi-circumferential arc of that portion. Furthermore, each groove 16 is preferably delimited by a respective pair of projections 18a, 18b, which are mutually spaced apart and which project radially from the external semi-cylindrical surface of the corresponding nozzle portion. The distance between the projections 18a, 18b is selected in such a manner that the profile 17 of the frame of the hood remains retained in a stable manner therebetween, in the mutual engagement condition, in order to ensure the axial retention action, without play, of the manifold with respect to the hood structure. It should be understood that various quantities of the pairs of projections 18a, 18b can be provided, for example, two, four or six in number, and being discontinuous between each other in the circumferential extent of the nozzle. Furthermore, as alternatives to the projections, there can be provided fins or similar extension pieces having a similar function.

[0023] Respective surface indentations which are formed at the opposing diametral ends of the nozzle portion 5a are designated 19. Those surface indentations have such an extent as to allow the nozzle portions to pivot, in a movement away from and towards the second operating position, without bringing about any interference between the ends thereof in the region in which they are positioned one above the other, as illustrated in Figure 2. Catch type connection means for securing the half-shells 4, 5 when they are pivoted into the first operating position are further generally designated 20. Those means comprise two respective pairs of tooth-like formations 21 on the half-shell 5, which are able to engage with respective catch type connection seats 22 which are formed, in a corresponding position, in the other half-shell 4. The catch type connection is ensured by the resilient return of the teeth in the state of engagement with the corresponding seats and is configured to be of the removable type so as to allow the operations for both connecting and disconnecting the half-shells to be rapid and simple.

[0024] During use, in order to fix the manifold to the hood, the half-shells are first pivoted into the position of Figure 2, in which the nozzle portions, which are moved towards each other with partial introduction one in the other, define a profile of the delivery cross-section having a small extent and such therefore as to allow the nozzle to be inserted in the opening of the hood 8 which is delimited by the (circular) profile of the projection 17. Figure 6 illustrates that operating position. Subsequent movement of the manifold in the axial direction Y is capable of moving the nozzle portions, with the profile 17 in correspondence with the grooves 16 which are substantially facing it. From that position, pivoting the half-shells until they reach the operating position of Figure 1, with the half-shells connected to each other in the plane P, brings

about engagement of the profile 17 in the respective grooves 16, with a consequent axial retention action of the manifold with respect to the frame of the hood. Reaching the connection position further brings about the engagement of the catch type connection means between the half-shells, ensuring relative securing thereof. The sequence of operations described, when carried out in reverse order, allows, vice versa, the disconnection of the manifold from the hood frame to be achieved, with the half-shells being opened and it consequently being possible to gain access to the ventilation unit which is received inside the manifold. Therefore, this also results in greater ease of disassembly during operations for servicing and maintaining the ventilation unit.

[0025] With reference to Figures 6 and 7, a flange for connecting the hood to the tubular discharge pipe is designated 23 and is schematically indicated, that flange ensuring the fluid-tight connection between the hood and the pipe for discharging the air-like gases which are drawn in by the ventilation unit. It will be further appreciated that, in the application of Figure 5, wherein an additional manifold pipe which is connected above the ventilation unit has not been provided, there is, principally, an advantageous reduction in the assembly times over known solutions.

[0026] The invention thereby achieves the objects set out, resulting in the advantages set out over known solutions.

[0027] These particularly include the greater speed and ease overall of the operations for assembling the manifold of the ventilation unit with respect to the intake hood structure with which it is intended to be connected.

Claims

1. A manifold, in particular a scroll type manifold, which is intended to constitute the housing of a fan impeller (2), comprising a pair of half-shells (4, 5) which can be connected to each other in a connection plane (P), each half-shell (4, 5) including a respective portion (4a, 5a) of a delivery nozzle (6) of the manifold, those nozzle portions (4a, 5a) together defining the delivery cross-section (3) of the manifold, **characterized in that** the half-shells (4, 5) of the manifold are articulated to each other about an articulation axis (Z), so as to be mutually pivotable between a first operating position in which the half-shells (4, 5) are connected along that plane (P) and the nozzle portions delimit the entire delivery cross-section (3), and a second operating position, in which the nozzle portions (4a, 5a) are moved towards each other with a consequent reduction in the extent of that delivery cross-section (3).
2. A manifold according to claim 1, wherein the articulation axis (Z) of the half-shells (4, 5) belongs to a central plane of symmetry of the manifold which ex-

tends perpendicularly relative to the axis of rotation (X) of the impeller (2).

3. A manifold according to claim 1 or claim 2, wherein the articulation axis (Z) extends in a region between the free end of the delivery nozzle (6) and the axis of rotation (X) of the impeller.
4. Manifold according to any one of the preceding claims, wherein there are provided, on each nozzle portion (4a, 5a) of the respective manifold half-shell (4, 5), retention means (14) which are able to cooperate with respective counter-retention means which are provided on a frame structure (15), to which the manifold is intended to be connected in a removable manner, those means and counter-means being able to engage with each other in the first operating position in order to retain the manifold with respect to the frame.
5. A manifold according to claim 4, wherein the retention means comprise a respective groove (16) and the counter-means comprise a respective projection (17) which is able to engage with the groove in order to retain the manifold with respect to the frame structure (15) in the first operating position.
6. A manifold according to claim 5, wherein the flow at the delivery cross-section (3) is directed in a main axial direction and the means and counter-means are able to engage with each other in order to retain the manifold with respect to the frame structure (15) in the axial direction.
7. A manifold according to any one of the preceding claims, wherein the nozzle portions (4a, 5a) substantially have a semi-cylindrical configuration and each corresponding groove (16) extends over at least a circumferential arc portion of the semi-cylindrical surface of the corresponding nozzle portion (4a, 5a).
8. A manifold according to claim 7, wherein each groove (16) is defined by at least a pair of projections (18a, 18b) which are mutually spaced apart and which project radially from the semi-cylindrical surface of the corresponding nozzle portion (4a, 5a), the projections extending over the corresponding circumferential arc portion.
9. A manifold according to any one of the preceding claims, wherein each of the diametrically opposed ends of at least one (5a) of the delivery nozzle portions comprises respective surface indentations (19) which are able to allow the other nozzle portion (4a) to pivot during the relative movement of those portions away from and towards the second operating position.

10. A manifold according to any one of the preceding claims, wherein there are provided relative articulation means between the two manifold half-shells (4, 5), the means comprising respective pin-like formations (12) at least on one (5) of the half-shells and respective, corresponding eyelet-like formations (13) on the other (4) of the half-shells, those eyelet-like formations and pin-like formations being able to bring about a hinge-like articulated connection by means of relative engagement of each pin-like formation (12) in the corresponding eyelet-like formation (13). 5 10
11. A manifold according to claim 10, wherein the pin-like formations (12) and the corresponding eyelet-like formations (13) are provided at diametrically opposed sides in a region near the delivery nozzle (6) of the manifold. 15
12. A manifold according to any one of the preceding claims, wherein the half-shells (4, 5) are mutually retained in the first operating position by catch type connection means and counter-means (21, 22) which are of the removable type and which are provided on the half-shells (4, 5) of the manifold, respectively. 20 25
13. A manifold according to claim 12, wherein the catch type connection means comprise tooth-like formations (21) on at least one (5) of the half-shell(s) which is/are able to engage with respective catch type connection seats (22) which are provided on the other (4) half-shell in a corresponding position. 30

35

40

45

50

55

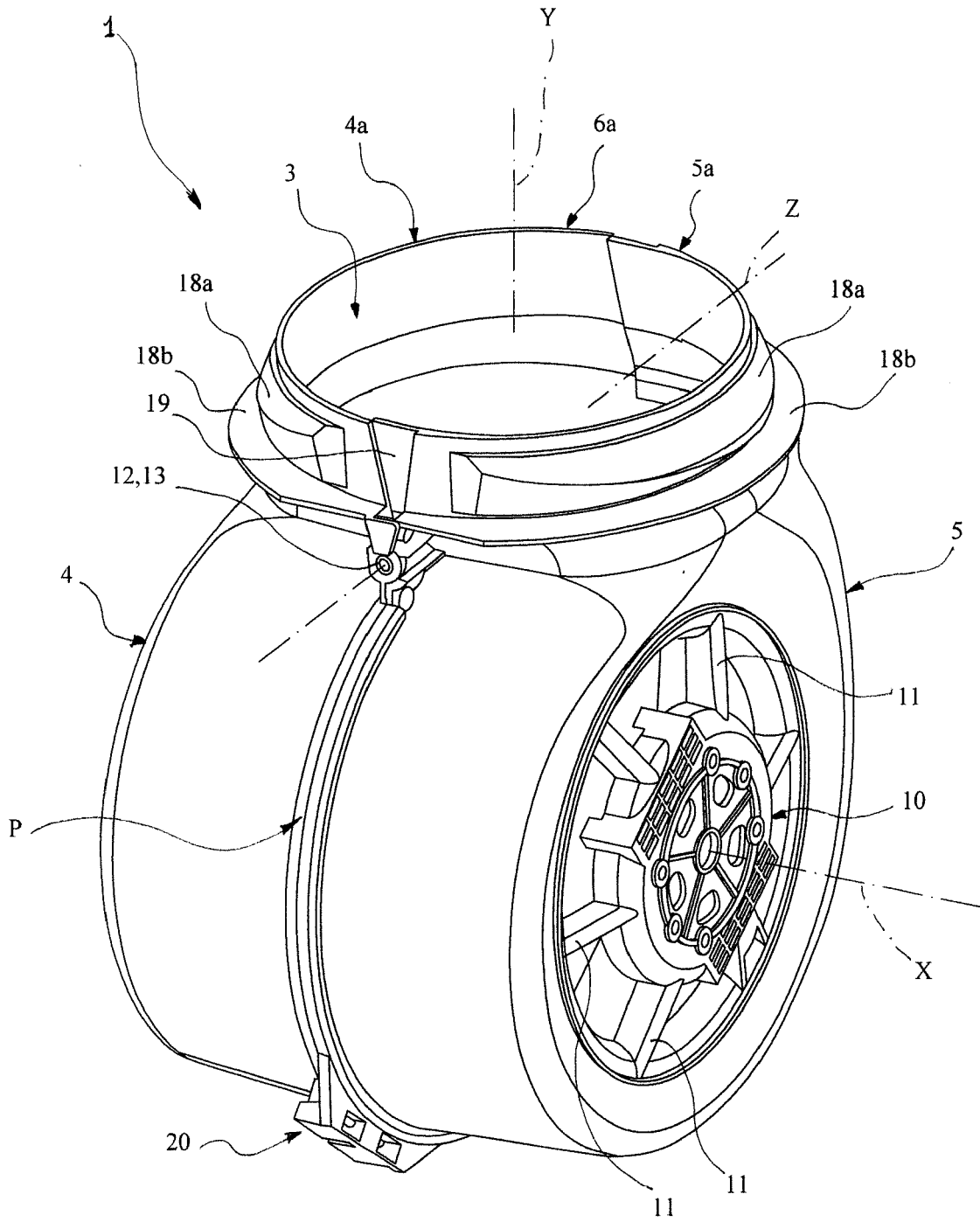

Fig. 1

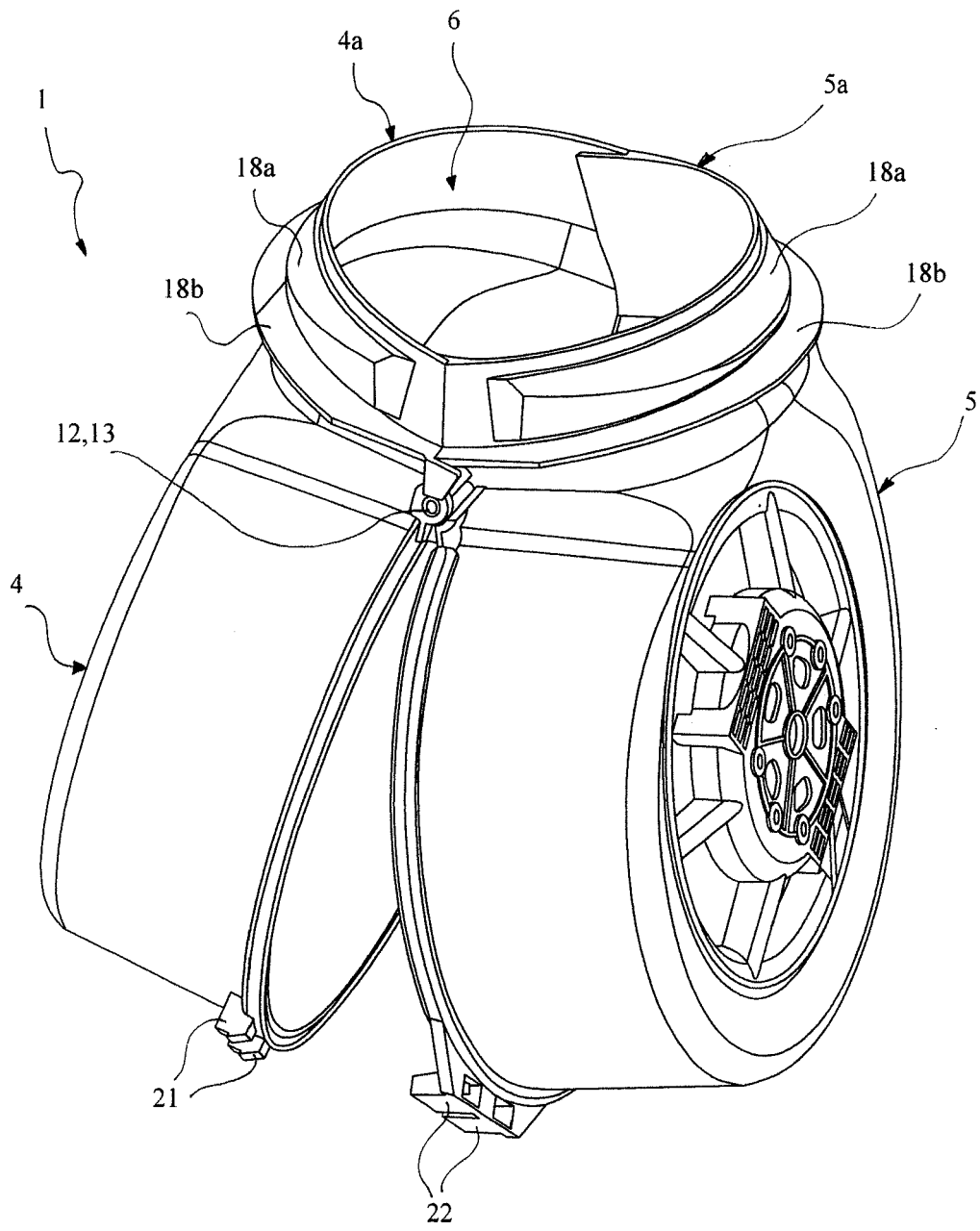

Fig. 2

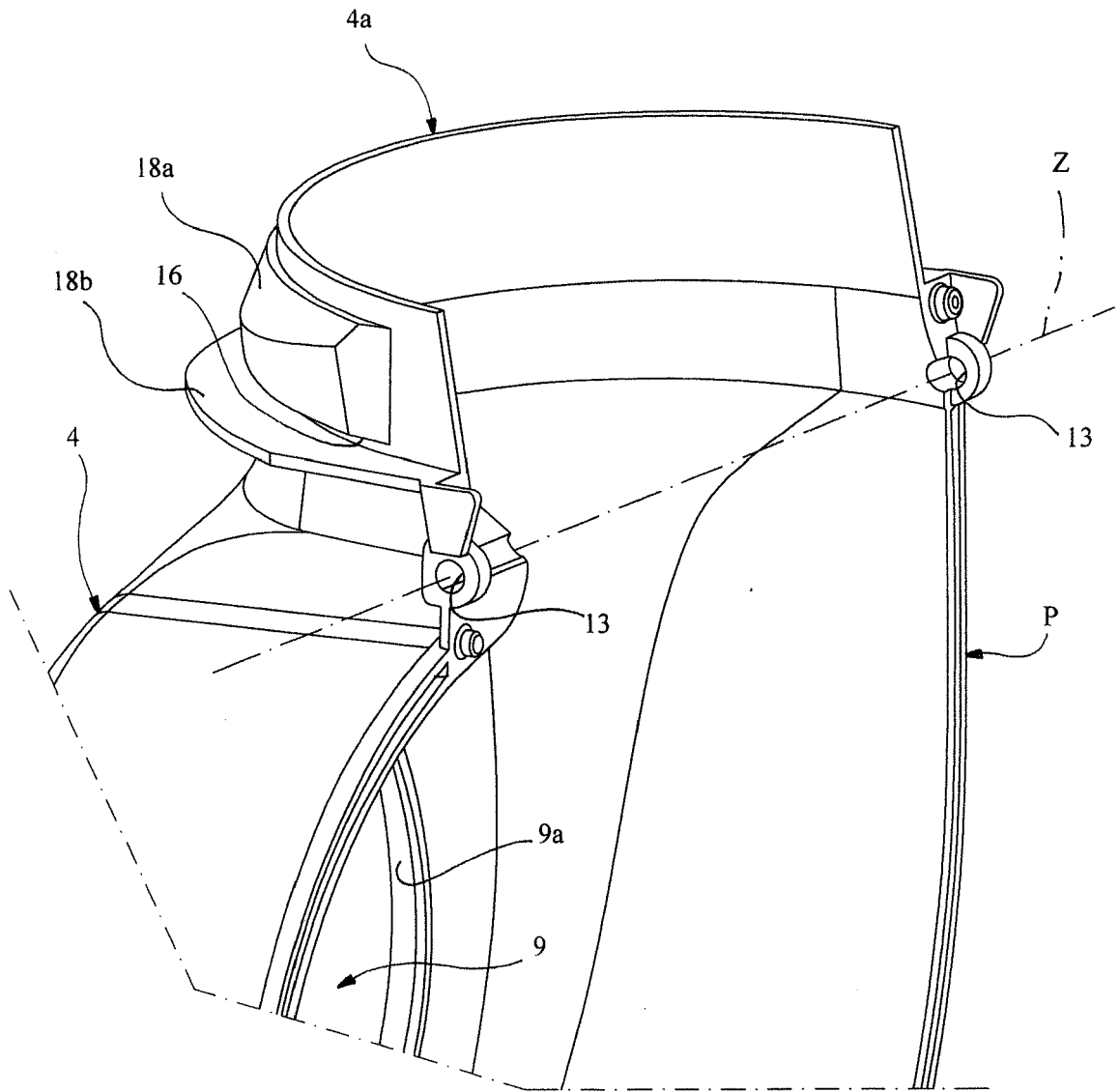

Fig. 3

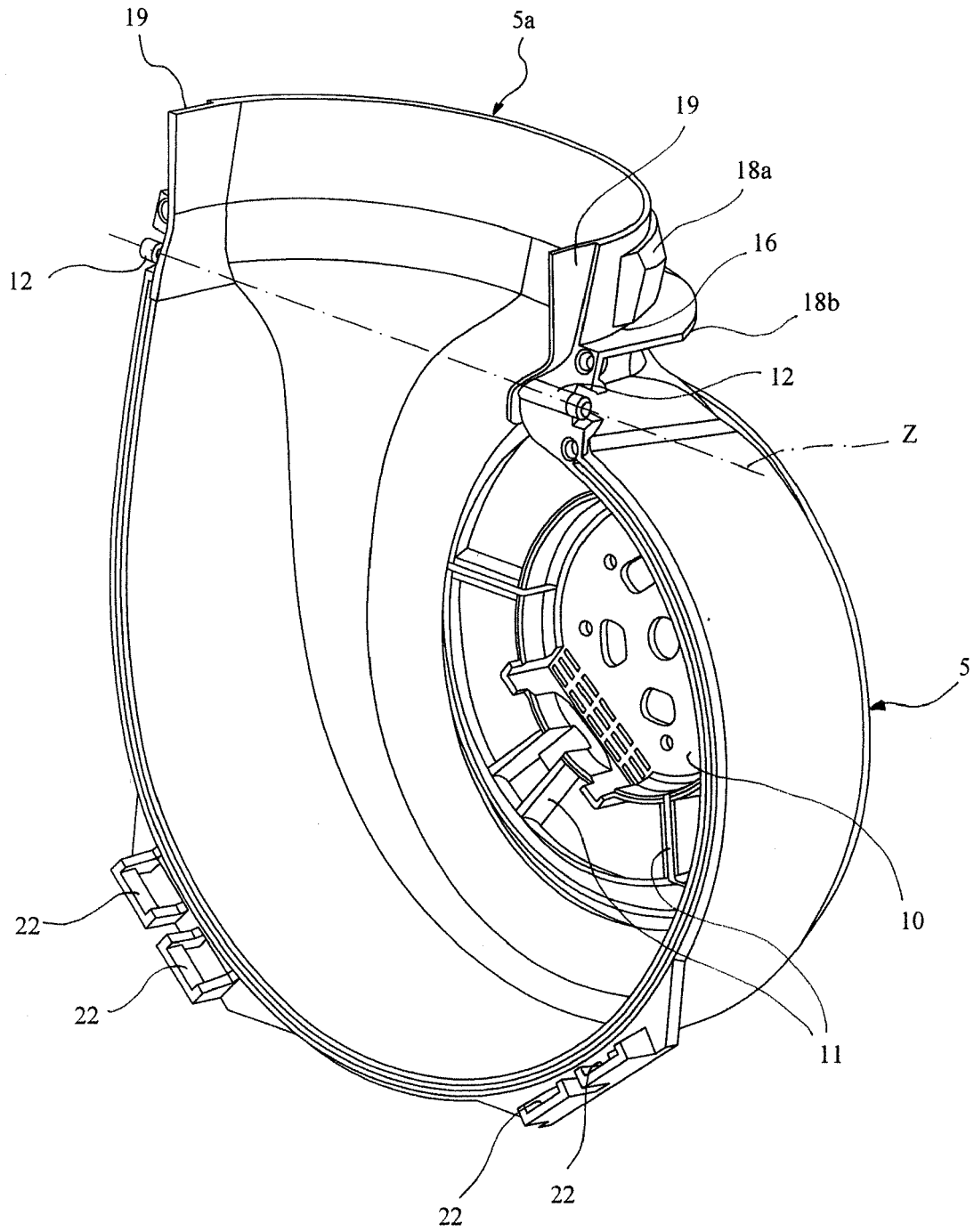

Fig. 4

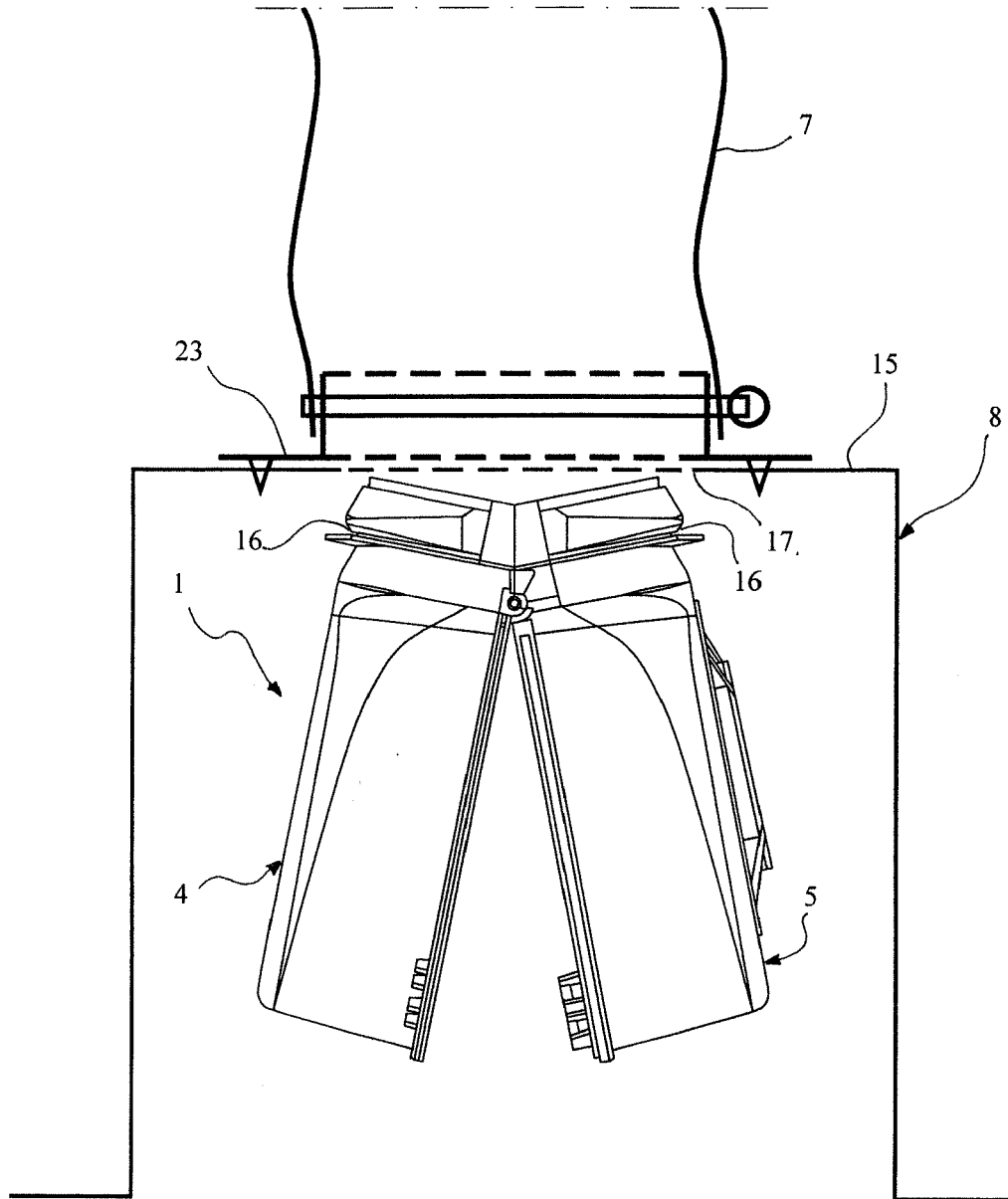

Fig. 6

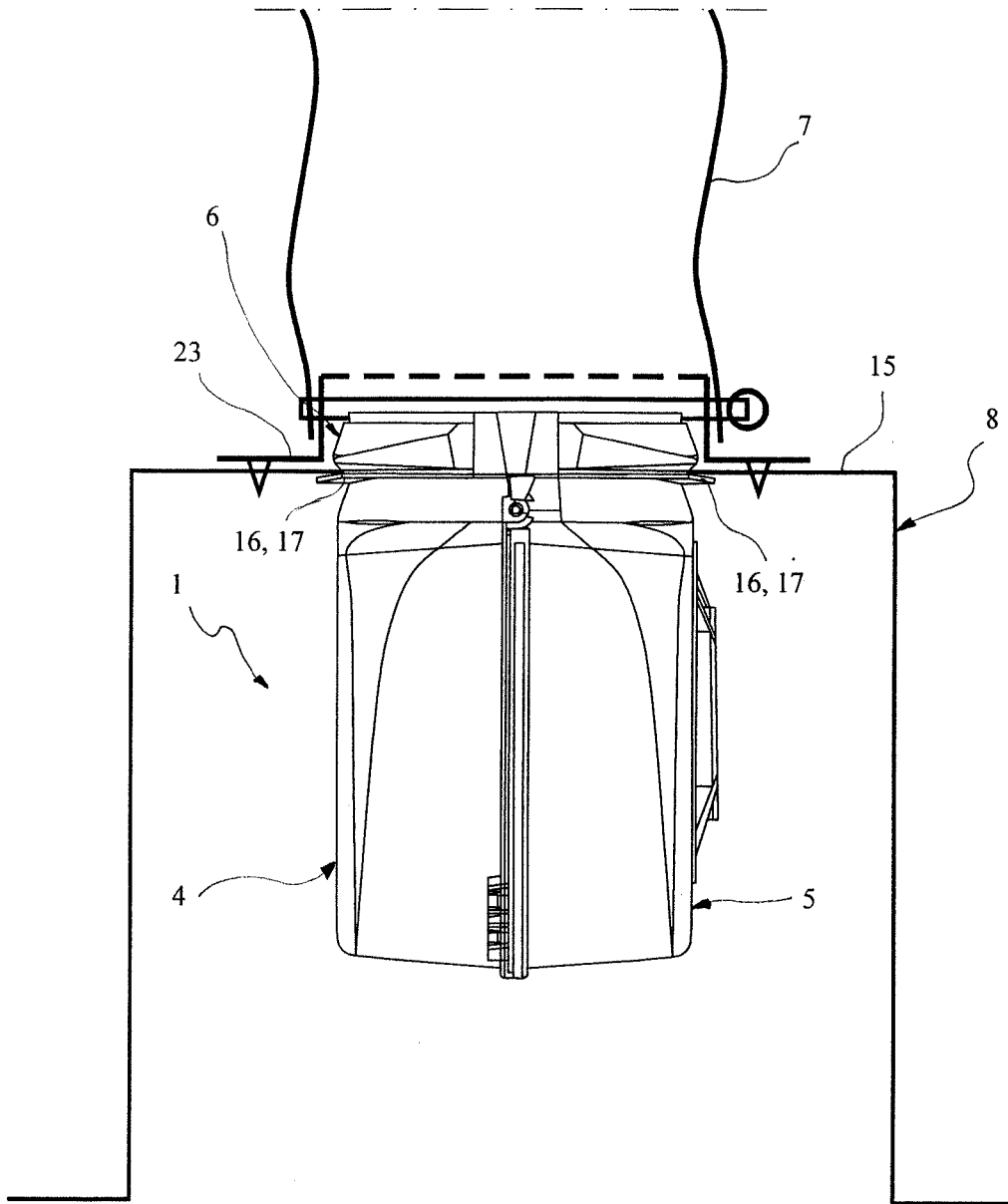

Fig. 7