

C. A. TOWER.  
CAR COUPLING.  
APPLICATION FILED JAN. 6, 1908.

997,219.

Patented July 4, 1911.

3 SHEETS—SHEET 1.

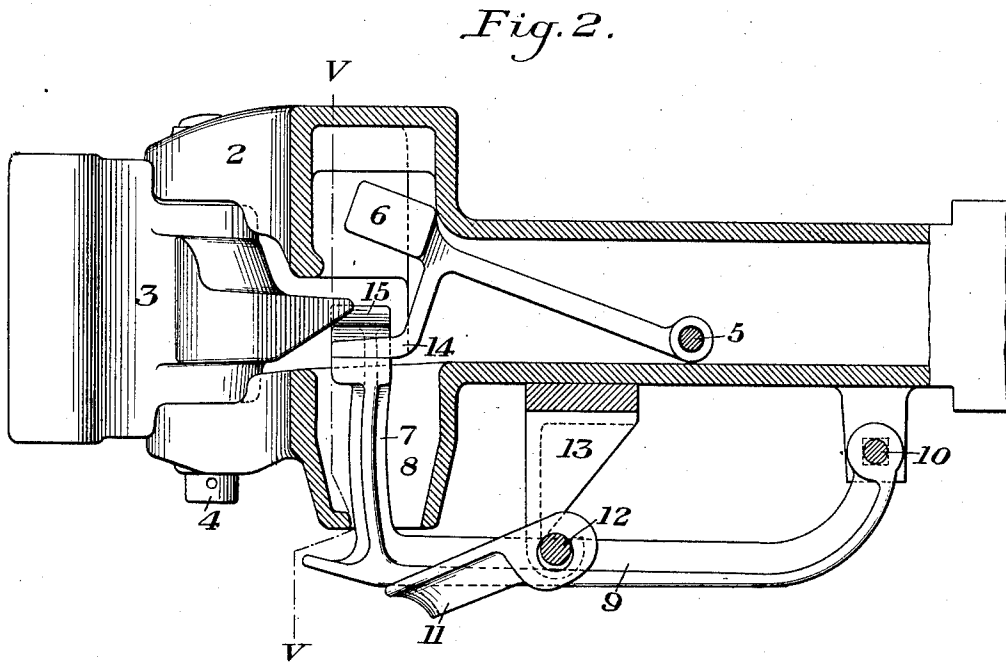
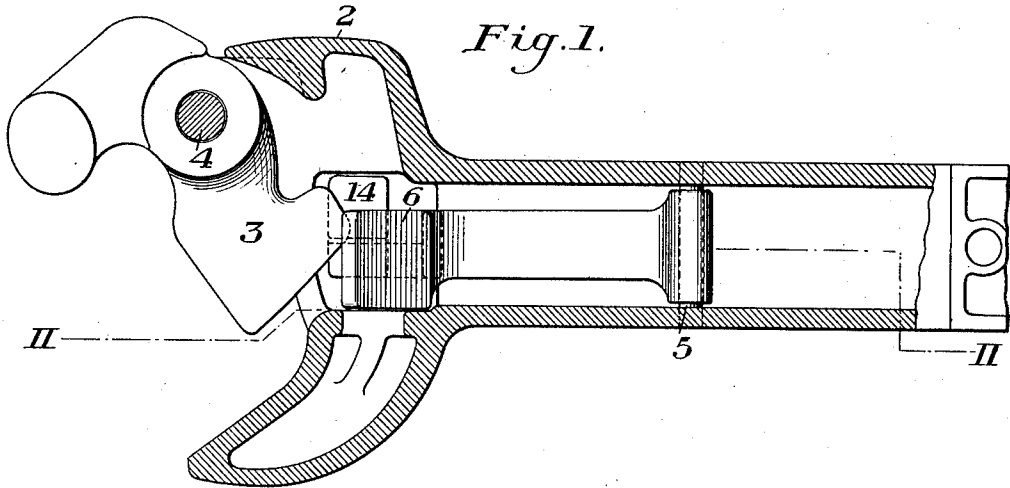

WITNESSES

*R. A. Balderson*  
*W. W. Swartz*

INVENTOR

*C. A. Tower*  
*by Bakewell, Bymer & Parmelee,*  
*his Attys.*

C. A. TOWER.  
 CAR COUPLING.  
 APPLICATION FILED JAN. 6, 1908.

997,219.

Patented July 4, 1911.

3 SHEETS—SHEET 2.

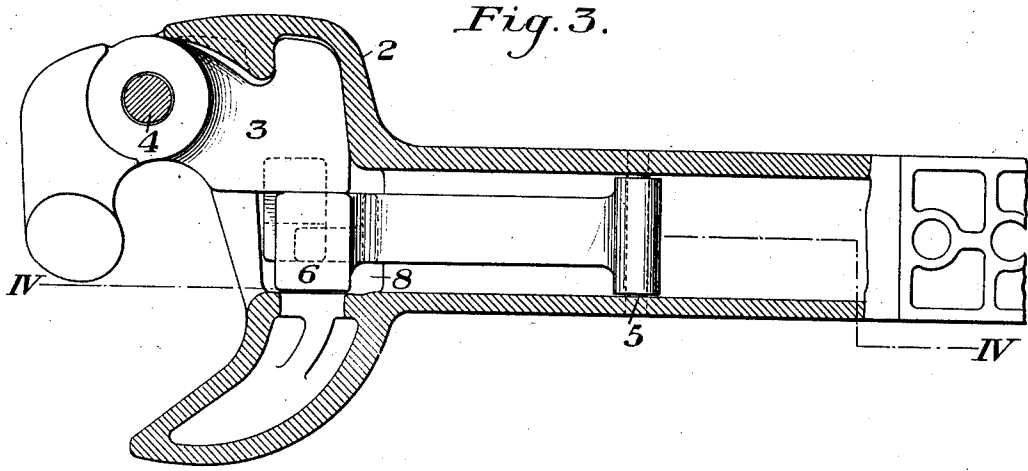

Fig. 3.

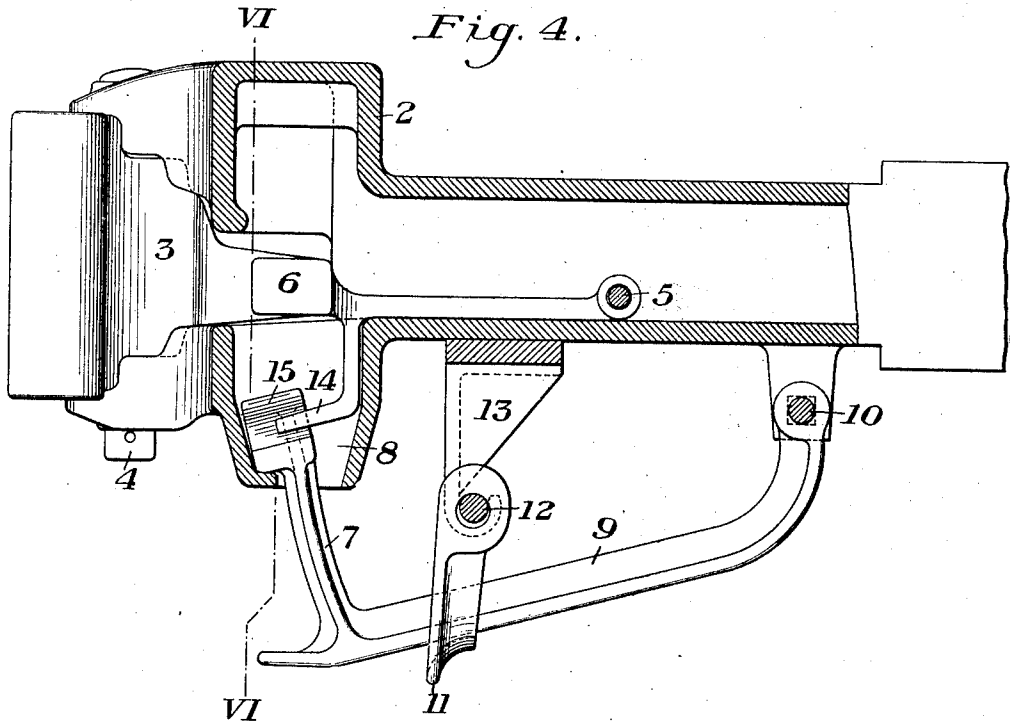

Fig. 4.

WITNESSES

*R. H. Balderson*  
*W. V. Swartz*

INVENTOR

*C. A. Tower,*  
*by Babewell, Pyms & Parmelee,*  
*his Attys.*

C. A. TOWER.  
CAR COUPLING.  
APPLICATION FILED JAN. 6, 1908.

997,219.

Patented July 4, 1911.

3 SHEETS—SHEET 3.

Fig. 5.

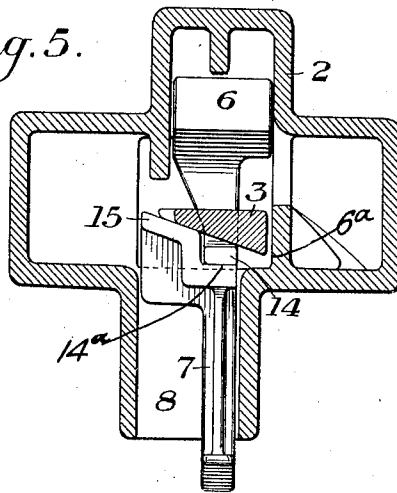
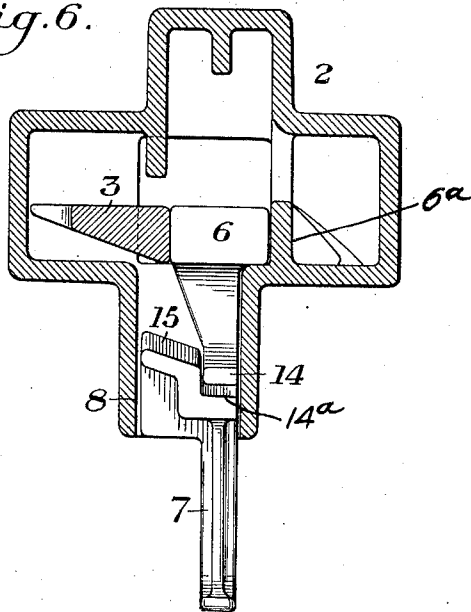

Fig. 6.



WITNESSES

*R. A. Baldwin*  
*W. W. Swartz*

INVENTOR

*C. A. Tower,*  
*by Baker, Byrnes, Parmelee,*  
*his Attys.*

# UNITED STATES PATENT OFFICE.

CLINTON A. TOWER, OF CLEVELAND, OHIO, ASSIGNOR TO THE NATIONAL MALLEABLE CASTINGS COMPANY, OF CLEVELAND, OHIO, A CORPORATION OF OHIO.

## CAR-COUPLING.

997,219.

Specification of Letters Patent.

Patented July 4, 1911.

Application filed January 6, 1908. Serial No. 409,424.

To all whom it may concern:

Be it known that I, CLINTON A. TOWER, of Cleveland, Cuyahoga county, Ohio, have invented a new and useful Improvement in Car-Couplers, of which the following is a full, clear, and exact description, reference being had to the accompanying drawings, forming part of this specification, in which—

Figure 1 is a horizontal section showing a coupler constructed in accordance with my invention, the swinging knuckle being in open position and shown in plan view; Fig. 2 is a vertical longitudinal section on the line II—II of Fig. 1; Fig. 3 is a horizontal section similar to Fig. 1, but showing the knuckle closed and locked; Fig. 4 is a vertical longitudinal section on the line IV—IV of Fig. 3; Fig. 5 is a vertical cross section on the line V—V of Fig. 2; and Fig. 6 is a similar section on the line VI—VI of Fig. 4.

In the drawings, 2 represents the coupler-head and 3 is the swinging knuckle, which may be of ordinary construction and is pivoted on a vertical axis 4 so that it may be swung into the open position shown in Fig. 1, in which position it is in readiness to couple with the coupler of another car, or into the closed and locked position shown in Fig. 3. The vertically moving locking member is preferably pivoted on a horizontal axis 5, although this pivoting is not essential to my invention, broadly considered, and it has a locking head 6 which, when in locked position, as shown in Figs. 3, 4 and 6, fits in front of and obstructs the tail of the knuckle. This head 6 is arranged to fit neatly in its locking position between the knuckle tail and the bearing surface 6<sup>a</sup> of the head, the latter acting as a thrust bearing. Its vertical movement is derived from a lifting arm 7 which extends upwardly through an opening 8 in the floor of the coupler and may be operated vertically by having a rearwardly extending arm 9, which is pivoted to the shank of the draw bar at 10. This arm 9 is preferably operated by a rocking yoke 11 mounted on a rock shaft 12 which is journaled in a bracket 13 depending from the carry iron of the coupler. This shaft extends to the side of the car and is operated by the trainman in the usual manner.

The upper end of the lifting arm 7 engages a downwardly and forwardly extending projection or portion 14 which depends from the locking head 6, so that when the lifting arm is moved vertically, it will raise the locking head away from the knuckle, as shown in Fig. 2, leaving the knuckle free to move open. For the purpose of moving the knuckle open without requiring the trainman to seize it with his hand, I provide the upper end of the lifting arm 7 with a cam device 15 which, when the lifting arm is raised, engages an inclined surface at the rear end of the tail of the knuckle and forces the knuckle into open position, as shown in Figs. 1, 2, and 5.

The upper end of the lifting arm 7 has a shoulder 14<sup>a</sup> to receive the relatively narrow depending portion 14 of the locking member, as best seen in Fig. 6, the cam portion 15 extending laterally and upward from said shoulder. The portion 14 being normally seated between the shoulder 14 and the adjacent wall of the opening 8, forms a further means for taking up lateral thrusts on the locking member.

I claim

A coupler having a pivoted knuckle, a locking member having a shank extending back within the shank of the coupler and arranged to permit up and down movement of said member, said member having a U-shaped head comprising a portion adapted to engage and lock the knuckle, and another and lower portion, and a lifting member for the lock extending upwardly into the coupler head through the bottom wall thereof, and having at its upper portion a shoulder which normally seats and has a lifting engagement with the lower portion of the head of the locking member, and the lifting member having a cam portion at one side of said shoulder which is arranged, when lifted, to engage and exert an opening action upon the knuckle tail; substantially as described.

In testimony whereof, I have hereunto set my hand.

CLINTON A. TOWER.

Witnesses:

HARRY E. ORR,  
JEANNETTE SACHEROFF.