

**(19) AUSTRALIAN PATENT OFFICE**

(54) Title  
Pusher mechanism for I.S. machine

(51)<sup>6</sup> International Patent Classification(s)  
C03B 9/453 (2006.01)5BHAU B65G  
B65G 47/02 (2006.01)47/02  
C03B 9/453 20060101ALI2007012  
20060101AFI2007012 5BHAU

(21) Application No: 2007200043 (22) Application Date: 2007.01.05

(30) Priority Data

(31) Number	(32) Date	(33) Country
11/351556	2006.02.10	<b>US</b>

(43) Publication Date : 2007.08.30  
(43) Publication Journal Date : 2007.08.30

(71) Applicant(s)  
Emhart Glass S.A.

(72) Inventor(s)  
Kammonen, Jarmo

(74) Agent/Attorney  
Griffith Hack, Level 29, Northpoint 100 Miller Street, North Sydney, NSW, 2060

2007200043 05 Jan 2007

ABSTRACT

5 A pusher mechanism for pushing bottles formed in  
an I.S. machine from a dead plate to a conveyor. The  
pusher mechanism includes a pusher finger assembly  
which is supported by a housing and is movable about an  
axis of support and about the parallel axis of rotation  
of the housing. The axis of the two drive gears for  
10 effecting these rotations are coaxial.

2007200043 05 Jan 2007

AUSTRALIA  
Patents Act 1990

COMPLETE SPECIFICATION  
STANDARD PATENT

**Applicant:**

EMHART GLASS S.A.

**Invention Title:**

PUSHER MECHANISM FOR I.S. MACHINE

The following statement is a full description of this invention, including the best method of performing it known to us:

2007200043 05 Jan 2007

SPECIFICATION

PUSHER MECHANISM FOR I.S. MACHINE

5           The present invention relates to pusher mechanisms  
which displace bottles formed in an I.S. machine from a  
deadplate to a conveyor.

BACKGROUND OF THE INVENTION

10           Glass bottles formed in an I.S. machine are  
deposited on a deadplate where they will be cooled for  
s short period of time and then pushed through an angle  
of about 90° onto a moving conveyor. Numerous designs  
15 are in the public domain: U.S. Patents Nos. 4,414,758  
and 6,702,097, CZ Patents Nos. 288,848 and 295,688, and  
U.S. Publications 2005/0199011 and 0193773.  
As the speed of these machines increases, the  
difficulty involved in controlling the bottles as they  
20 are displaced increases.

OBJECT OF THE INVENTION

25           It is accordingly an object of the present  
invention to provide a pusher mechanism that can  
smoothly displace bottles from the deadplate to the  
conveyor.

30           Other objects and advantages of the present  
invention will become apparent from the following  
portion of this specification and from the accompanying  
drawings which illustrate, in accordance with the  
mandate of the patent statutes, a presently preferred  
embodiment incorporating the principles of the  
invention.

BRIEF DESCRIPTION OF THE DRAWINGS

Figure 1 is an oblique view of a pusher mechanism  
5 made in accordance with the teachings of the present  
invention;

Figure 2 is an exploded oblique view of a portion  
of the pusher mechanism shown in Figure 1;

Figure 3 is an exploded oblique view of another  
10 portion of the pusher mechanism shown in Figure 1; and

Figure 4 is an oblique view of a pusher finger  
assembly.

BRIEF DESCRIPTION OF THE PREFERRED EMBODIMENT

15

The pusher mechanism is disclosed in Figure 1 and  
includes first and second servo motors 10, 12, a lower  
pusher housing 14, and an upper pusher housing 16.  
Referring to Figure 2, the servo motors are secured to  
20 the bottom of the lower pusher housing and each  
includes a gearbox 18. Secured to the top of the  
second servo motor is a first drive gear 20 which is  
interconnected with a first driven gear 22 via a first  
pulley 24. The first driven gear, which is supported  
25 by an annular flat bearing 26 defined in the lower  
housing, rotates about a first axis A1. The top  
surface 27 of this first driven gear 22 extends through  
an opening 28 in the lower housing cover plate 30 and  
is connected via suitable screws 32 to the bottom of  
30 the upper housing. Rotation of the second motor will  
accordingly result in rotation of the upper pusher  
housing about the first axis.

Secured to the top 38 of the first motor gearbox  
is a mounting post 40 which extends vertically upwardly  
35 through the central hole 42 in the first driven gear  
22. Secured to the top of this mounting post 40, via

suitable screws 43, is a second drive gear 44 which is housed within the upper pusher housing 16. Also supported within the upper pusher housing, is a second driven gear 45 mounted on a shaft 46. The shaft 46 is rotatably supported by upper and lower bearings 47 for rotation about a second axis A2. This shaft projects upwardly past the cover plate 48 of the upper pusher housing.

Figure 4 shows a pusher finger assembly 50 including a bracket 52 having a vertical hole 54 for receiving the shaft 46 (secured by a clamp 54 having a number of screws 56). A finger bar 58 having three bottle engaging fingers 60, is secured to the bracket via an "L" shaped arm 62 and intermediate bracket 64. The pusher finger assembly will be pivoted about axis A2 by operation of the first servo motor 10.

In the claims which follow and in the preceding description of the invention, except where the context requires otherwise due to express language or necessary implication, the word "comprise" or variations such as "comprises" or "comprising" is used in an inclusive sense, i.e. to specify the presence of the stated features but not to preclude the presence or addition of further features in various embodiments of the invention.

A reference herein to a prior art document is not an admission that the document forms part of the common general knowledge in the art in Australia.

CLAIMS

1. A pusher mechanism for pushing bottles formed in an  
5 I.S. machine through an angle of about 90° from a  
deadplate to a moving conveyor comprising a pocket  
finger assembly including a pocket finger arm having at  
least one pocket for receiving a bottle on the dead  
plate,  
10 a first motor,  
a lower housing,  
an upper housing,  
a first driven gear, having a hollow center,  
mounted in said lower housing for rotation about a  
15 first vertical axis, said first driven gear secured to  
said upper housing,  
first coupling means for interconnecting said  
first motor and said first driven gear for rotating  
said upper housing about said first axis,  
20 a second motor,  
a second driven gear rotatably mounted on said  
upper housing for rotation about a second axis parallel  
to said first axis,  
a first shaft axially vertically upwardly  
25 extending from said second driven gear,  
said pocket finger assembly secured to said first  
shaft for rotation about said second vertical axis,  
second coupling means including a second  
vertically extending shaft extending through said  
30 hollow center of said first driven gear for  
interconnecting said second motor and said second  
driven gear.

2. A pusher mechanism according to claim 1, wherein said first coupling means comprises a first drive gear and a first drive pulley interconnecting said first drive gear and said first driven gear.

5

3. A pusher mechanism according to claim 2, wherein said second coupling means comprises a second drive gear connected and a second drive pulley interconnecting said second drive gear and said second driven gear.

10

4. A pusher mechanism according to claim 3, wherein said first motor includes a first gear box connected to said first drive gear.

15

5. A pusher mechanism according to claim 4, further comprising a second gear box connected to said second drive gear.

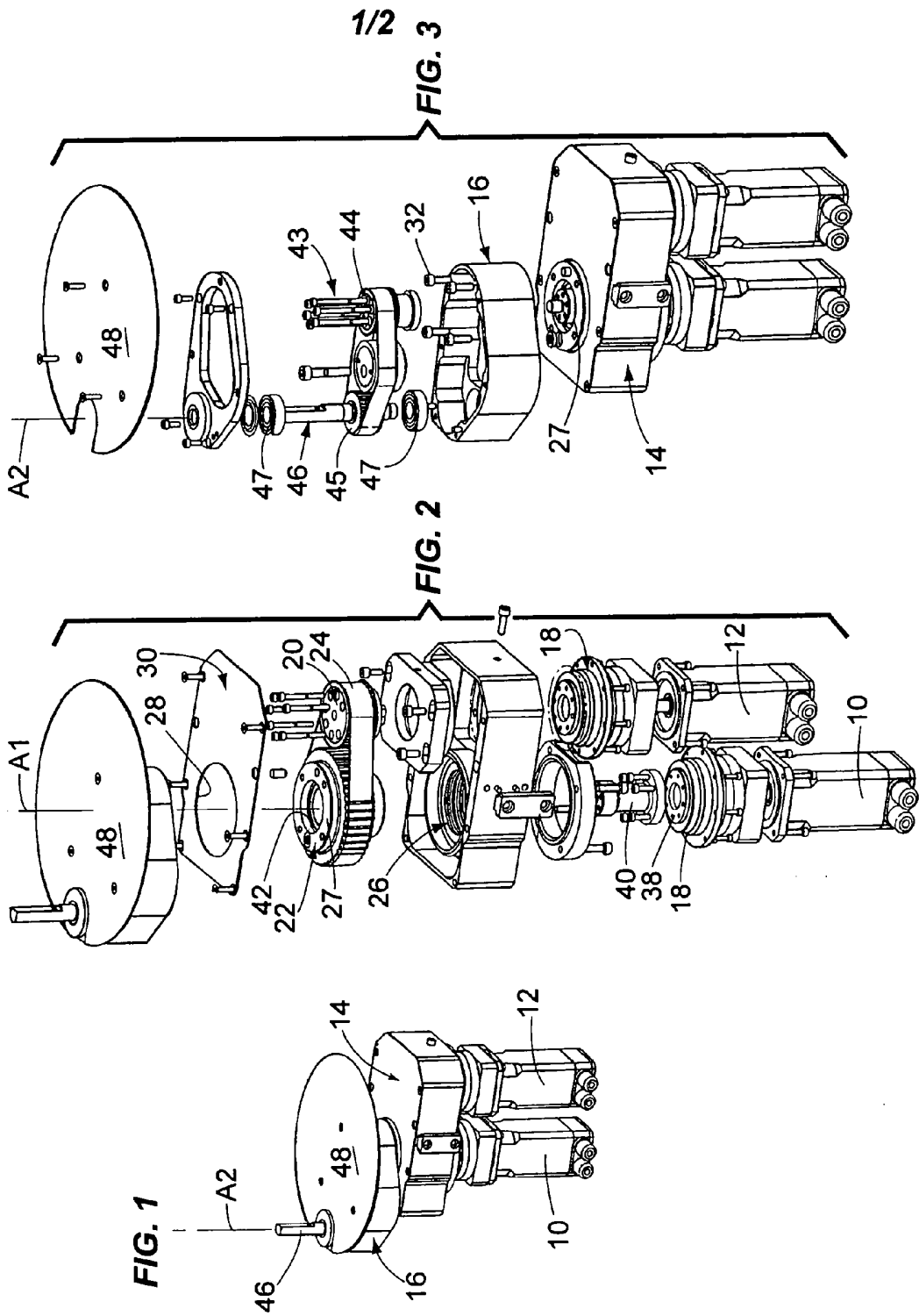

2/2

