



INTERNATIONAL APPLICATION PUBLISHED UNDER THE PATENT COOPERATION TREATY (PCT)

<p>(51) International Patent Classification ⁶ : E21B 29/06, 27/00, 7/28, 4/16</p>	<p>A1</p>	<p>(11) International Publication Number: WO 99/64715</p> <p>(43) International Publication Date: 16 December 1999 (16.12.99)</p>
<p>(21) International Application Number: PCT/EP99/04039</p> <p>(22) International Filing Date: 9 June 1999 (09.06.99)</p> <p>(30) Priority Data: 98304595.6 10 June 1998 (10.06.98) EP</p> <p>(71) Applicant (for all designated States except CA): SHELL INTERNATIONALE RESEARCH MAATSCHAPPIJ B.V. [NL/NL]; Carel van Bylandtlaan 30, NL-2596 HR The Hague (NL).</p> <p>(71) Applicant (for CA only): SHELL CANADA LIMITED [CA/CA]; 400 - 4th Avenue S.W., Calgary, Alberta T2P 2H5 (CA).</p> <p>(72) Inventors: AMORY, Marc, Emmanuel; Volmerlaan 6, NL-2288 GD Rijswijk (NL). FISHER, Simon, Lawrence; Volmerlaan 6, NL-2288 GD Rijswijk (NL). POINTING, Michael, Edward; Volmerlaan 6, NL-2288 GD Rijswijk (NL). WILLEMSE, Onno; Volmerlaan 6, NL-2288 GD Rijswijk (NL). ANDERSON, Mark, Wilson; Volmerlaan 6, NL-2288 GD Rijswijk (NL).</p>		<p>(81) Designated States: AE, AL, AM, AT, AU, AZ, BA, BB, BG, BR, BY, CA, CH, CN, CU, CZ, DE, DK, EE, ES, FI, GB, GD, GE, GH, GM, HR, HU, ID, IL, IN, IS, JP, KE, KG, KP, KR, KZ, LC, LK, LR, LS, LT, LU, LV, MD, MG, MK, MN, MW, MX, NO, NZ, PL, PT, RO, RU, SD, SE, SG, SI, SK, SL, TJ, TM, TR, TT, UA, UG, UZ, VN, YU, ZA, ZW, ARIPO patent (GH, GM, KE, LS, MW, SD, SL, SZ, UG, ZW), Eurasian patent (AM, AZ, BY, KG, KZ, MD, RU, TJ, TM), European patent (AT, BE, CH, CY, DE, DK, ES, FI, FR, GB, GR, IE, IT, LU, MC, NL, PT, SE), OAPI patent (BF, BJ, CF, CG, CI, CM, GA, GN, GW, ML, MR, NE, SN, TD, TG).</p> <p>Published <i>With international search report. Before the expiration of the time limit for amending the claims and to be republished in the event of the receipt of amendments.</i></p>

(54) Title: DOWNHOLE MILLING DEVICE

(57) Abstract

A device for performing milling operations in an underground borehole comprises a toppling head (2) which is pivotably secured to a stator housing (1) and which is equipped with one or more rotatable mills (3, 4) which are in use pivoted together with the toppling head (2) into an extended position from the stator housing (1) to mill a window in a surrounding casing (23), or to underream the wellbore whilst the stator housing is rotated in the wellbore.

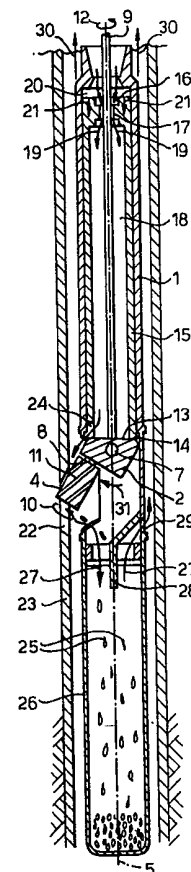

FOR THE PURPOSES OF INFORMATION ONLY

Codes used to identify States party to the PCT on the front pages of pamphlets publishing international applications under the PCT.

AL	Albania	ES	Spain	LS	Lesotho	SI	Slovenia
AM	Armenia	FI	Finland	LT	Lithuania	SK	Slovakia
AT	Austria	FR	France	LU	Luxembourg	SN	Senegal
AU	Australia	GA	Gabon	LV	Latvia	SZ	Swaziland
AZ	Azerbaijan	GB	United Kingdom	MC	Monaco	TD	Chad
BA	Bosnia and Herzegovina	GE	Georgia	MD	Republic of Moldova	TG	Togo
BB	Barbados	GH	Ghana	MG	Madagascar	TJ	Tajikistan
BE	Belgium	GN	Guinea	MK	The former Yugoslav Republic of Macedonia	TM	Turkmenistan
BF	Burkina Faso	GR	Greece			TR	Turkey
BG	Bulgaria	HU	Hungary	ML	Mali	TT	Trinidad and Tobago
BJ	Benin	IE	Ireland	MN	Mongolia	UA	Ukraine
BR	Brazil	IL	Israel	MR	Mauritania	UG	Uganda
BY	Belarus	IS	Iceland	MW	Malawi	US	United States of America
CA	Canada	IT	Italy	MX	Mexico	UZ	Uzbekistan
CF	Central African Republic	JP	Japan	NE	Niger	VN	Viet Nam
CG	Congo	KE	Kenya	NL	Netherlands	YU	Yugoslavia
CH	Switzerland	KG	Kyrgyzstan	NO	Norway	ZW	Zimbabwe
CI	Côte d'Ivoire	KP	Democratic People's Republic of Korea	NZ	New Zealand		
CM	Cameroon			PL	Poland		
CN	China	KR	Republic of Korea	PT	Portugal		
CU	Cuba	KZ	Kazakstan	RO	Romania		
CZ	Czech Republic	LC	Saint Lucia	RU	Russian Federation		
DE	Germany	LI	Liechtenstein	SD	Sudan		
DK	Denmark	LK	Sri Lanka	SE	Sweden		
EE	Estonia	LR	Liberia	SG	Singapore		

DOWNHOLE MILLING DEVICE

Background of the invention

The invention relates to a device for performing milling operations in an underground borehole. Such milling operations may include the underreaming of the borehole or the cutting of a window in a well tubular.

US patent specification No. 5,551,509 and International patent application PCT/GB95/02267, publication number WO 96/09460, disclose the use of a rotary milling tool which is induced to cut a window in a well casing by pressing a rotating mill downwards along the slant surface of a whipstock which is fixed within the well casing at the location where the window is to be milled. UK patent application GB 2,306,985 discloses a mill which is pressed radially into the casing to be milled by means of hydraulic pistons which protrude in a radial direction from the bit motor housing and which are actuated by the elevated pressure of the fluid which simultaneously actuates the hydraulic bit motor. The fluid is injected via a coiled tubing which is also used to pull or push the mill in longitudinal direction through the casing during the window cutting operation.

Disadvantages of the known window milling devices are that the shape and position of the window cut thereby is rather imprecise, that the window cutting operations are time consuming and generate a significant amount of sometimes coarse cuttings which are difficult to remove from the well.

A further disadvantage of the known milling devices is that the rotating mill exerts a high and variable tangential torque to the device which induces the device to run away in tangential direction. The known devices

- 2 -

therefore need to be guided by guide means, such as a whipstock, which is fixed firmly inside the casing to avoid the device to run away during the milling operations.

5 It is an object of the present invention to alleviate the disadvantages of the known milling devices.

Summary of the Invention

The device according to the present invention thereto comprises a stator housing, a toppling head which is pivotably secured to the housing and equipped with a number of rotatable mills, a drive mechanism for rotating each mill relative to the toppling head, and a pivot mechanism for pivoting the toppling head relative to the housing between a contracted position in which each mill is substantially aligned with the stator housing and an extended position in which each mill protrudes at an angle in a lateral direction away from the housing.

15 Preferably the device is equipped with a pair of contra-rotatable mills that exert opposite tangential torques to the device which neutralise each other.

Such contra-rotating mills are able to cut in the casing or other well tubular a well-defined window having well-polished rims which can be sealed off easily.

25 Preferably, the stator housing defines a longitudinal central plane of the device and the drive mechanism comprises a flexible drive shaft which is rotatable about an axis of rotation located in said central plane and which forms an input shaft of a gearwheel mechanism within the toppling head, which gearwheel mechanism comprises a pair of contra-rotating output shafts on which the mills are mounted.

30 It is also preferred that the pivot mechanism allows the toppling head to pivot relative to the stator housing about a pivot axis which is substantially orthogonal to said central plane, that the output shafts are rotatable

35

about axes of rotation which are parallel to each other and which are located at substantially equal distances from the central plane of the device and that the mills comprise substantially cylindrical bodies on which
5 helical cutting teeth are mounted such that the helix angles of the cutting teeth are identical but opposite to each other and the cutting teeth of adjacent mills face each other at or near said central plane.

Suitably the drive mechanism comprises a hydraulic
10 Moineau-type motor having a rotor which is rotatably mounted at the upper end of the stator housing and which is secured to the upper end of the flexible drive shaft and the pivot mechanism comprises a hydraulic piston which is slidably arranged within the stator housing
15 between the outlet of the Moineau-motor and a slant upper surface of the toppling head such that in use the elevated pressure of the driving fluid discharged by the motor presses the piston against said slant upper surface of the toppling head thereby inducing the toppling head
20 to pivot towards the extended position thereof.

In that case it is preferred that the hydraulic piston is slidably arranged around the flexible shaft and the flexible shaft is made of a resilient material and exerts a residual torque to the toppling head which
25 torque induces the toppling head to pivot towards its contracted position in the absence of hydraulic pressure exerted to the piston.

It is also preferred that if the device is used as a casing window milling device a cuttings collecting box is
30 secured to the housing beneath the mills and in use the hydraulic driving fluid emerging from the motor flushes cuttings from the mills into the cuttings collecting box.

Brief description of the drawings

These and other features, objects and advantages of
35 the milling device according to the present invention

will be made apparent by the following detailed description with reference to the drawings, in which:

Fig. 1 is a side view of the milling device according to the invention with a pair of mills in a retracted position;

Fig. 2 is a schematic longitudinal sectional view of the milling device of claim 1;

Fig. 3 shows the milling device of Fig. 2 wherein the mills are extended and are cutting a window in a well casing; and

Fig. 4 shows an alternative embodiment of the device according to the invention where the device is used as a wellbore underreamer.

Detailed Description of the Invention

Referring to Fig. 1 there is shown a milling device having a stator housing 1, a toppling head 2 and a pair of contra-rotating twin mills 3 and 4. The twin mills 3 and 4 face each other at a central plane of symmetry of the device which is orthogonal to the plane of drawing of Fig. 1 and which intersects the plane of the drawing at central axis 5.

The toppling head 2 is pivotably suspended within the stator housing 1 by a pair of hinge pins 6 which permit the toppling head 2 to rotate about an axis of rotation 7 which is substantially orthogonal to the central axis 5 and the central plane of symmetry of the device.

The toppling head 2 comprises a gear box (not shown) having a flexible input shaft 9 and a pair of parallel output shafts 8 which carry the mills 3 and 4 and which are rotated relative to the toppling head 2 at equal rotational speeds but in opposite directions, which are illustrated by arrows 10, in response to rotation illustrated by arrow 12 of the flexible input shaft 7 relative to the stator housing 1 by means of a

Moineau-type or other hydraulic or electric motor (not shown).

5 The mills 3 and 4 comprise substantially cylindrical bodies on which helical cutting teeth 11 are mounted at similar but opposite pitch angles which teeth intermesh at the central plane of symmetry of the device.

10 When the milling device is lowered through the well the toppling head 2 and the mills 3 and 4 are in a retracted transportation mode in which the mills 3 and 4 are substantially parallel to the central axis 5 of the device and do not protrude from the stator housing 1, as illustrated in Figs. 1 and 2. Fig. 2 shows that in the transportation mode the flexible shaft 9 obtains a curved shape and that the toppling head 2 has a slant upper surface 13 which has a top 14 that engages the lower end of a piston 15 which is slidably arranged inside the stator housing 1.

15 The piston 14 and slant upper surface 13 of the toppling head together form a pivoting mechanism which causes the toppling head 2 to rotate towards its extended position which is shown in Fig. 3.

20 Fig. 3 shows that liquid discharged by the hydraulic motor flows through an annular opening 16 between the upper end 17 of the piston 15 and the flexible shaft 9 into the interior 18 of the piston 15, as illustrated by arrows 19.

25 As a result of the flow restriction of the annular opening 16 a hydraulic pressure difference is created between the cavity 20 above the piston 15 and the piston interior 18 which induces the piston to slide downwards through the stator housing 1 as illustrated by arrows 21. The downward motion of the piston also pushes the top 14 of the slant upper surface 13 of the toppling head 2 downwards which causes the toppling head 2 to pivot about pivot axis 31 as illustrated by arrow 31.

30

35

- 6 -

The mills 3 and 4 pivot together with the toppling head 2 about the pivot axis 7 towards their extended position and are simultaneously rotated by the shafts 8 and thereby mill a window 22 in a casing 23 surrounding the device.

The outward pivoting of the mills 3 and 4 continues until the entire slant upper surface 13 of the toppling head 2 engages the lower end of the piston 15, in which position the mills 3 and 4 protrude at a predetermined orientation from the stator housing 1. Liquid is discharged from the interior 18 of the piston via an outlet opening 24 which injects the liquid at high speed towards the mills 3 and 4 thereby cooling the cutting teeth 11 thereof and flushing away cuttings 25. The liquid is then circulated through a cuttings collecting box 26 which is suspended at the bottom of the stator housing 1 as illustrated by arrows 27. A guide plate 28 in the collecting box 26 serves to reduce the speed of the liquid so that the cuttings are allowed to be separated by gravity and/or magnetic forces from the liquid and are deposited at the bottom of the box, whereas the liquid is discharged via an opening 29 at the top of the box 26 into the annulus surrounding the device.

While the mills 3 and 4 are cutting the window 22 in the well casing 23 the device is pulled upwards through the casing as illustrated by arrows 30 by means of a piston (not shown) above the device until the window 22 has the desired length. It is preferred that the device is suspended within the casing 23 from a coiled tubing or drill string (not shown) and that the coiled tubing or drill string is gradually pulled up during the milling operations whilst the piston above the device ensures that the device is moved up through the casing 23 at an

accurately defined speed and over an accurately defined distance.

The balanced forces exerted by the mills 3 and 4 to the stator housing allow the device to mill a straight and well defined window in the well casing 23 in a quick and accurate manner and without leaving cuttings in the casing interior. It will be understood that, if desired, the mills may have a non-cylindrical shape, such as a frusto-conical shape. In such case it is preferred that the axes of rotation of the mills intersect each other at the central plane of the device.

Fig. 4 shows an embodiment of the device according to the invention where the device is used for underreaming of an uncased underground borehole.

The upper part of the device shown in Fig. 4 is similar to the upper part of the device shown in Figs. 1-3 and similar reference numerals denote similar components.

The device shown in Fig. 4 however contains no cuttings collection box and has a stator housing 1 which is rotated about the central axis 5 as is illustrated by arrow 40.

The device of Fig. 4 is equipped with a single mill 4 which underreams the wellbore 41 as a result of the simultaneous rotation of the stator housing and of the mill 4 relative to the toppling head 2. The toppling head 2 is extended and retracted in the same way as described with reference to Figs. 1-3.

The flexible shaft 9 is connected to the output shaft 8 via a gearbox in the toppling head 2, or may alternatively be integrated with the output shaft 8. If desired the underreamer device shown in Fig. 4 may be equipped with a pair of contra-rotatable twin mills 4 similar to those shown in Figs. 1-3.

C L A I M S

1. A device for performing milling operations in an underground borehole, the device comprising a stator housing, a toppling head which is pivotably secured to the housing and equipped with a number of rotatable mills, a drive mechanism for rotating each mill relative to the toppling head, and a pivot mechanism for pivoting the toppling head relative to the housing between a contracted position in which each mill is substantially aligned with the stator housing and an extended position in which each mill protrudes at an angle in a lateral direction away from the housing.
2. The device of claim 1, wherein stator housing defines a longitudinal central plane of the device and the drive mechanism comprises a flexible drive shaft which is rotatable about an axis of rotation located in said central plane and which forms an input shaft that is directly or indirectly connected to each output shaft on which a mill is mounted.
3. The device of claim 2, wherein the pivot mechanism allows the toppling head to pivot relative to the stator housing about a pivot axis which is substantially orthogonal to the central plane of the device.
4. The device of claim 3, wherein the toppling head is equipped with a pair of contra-rotatable mills that are mounted on output shafts that are rotatable about axes of rotation which are parallel to each other and located at substantially equal distances from the central plane of the device and which mills comprise substantially cylindrical bodies on which helical cutting teeth are mounted such that the helix angles of the cutting teeth are identical but opposite to each other and the cutting

teeth of adjacent mills face each other at or near the central plane of the device.

5 5. The device of claim 2, wherein the toppling head is equipped with a pair of contra-rotatable mills that are mounted on output shafts which are rotatable about axes of rotation which intersect each other at a point of intersection located in said central plane and the mills have frusto-conical bodies on which intermeshing cutting teeth are mounted.

10 6. The device of claim 2, wherein the drive mechanism comprises a hydraulic motor having a rotor which is rotatably mounted within the stator housing and which is secured to the flexible drive shaft.

15 7. The device of claim 6, wherein the hydraulic motor is a Moineau-type motor which is located at an upper end of the stator housing and wherein the pivot mechanism comprises a hydraulic piston which is slidably arranged within the stator housing between the outlet of the Moineau-motor and a slant upper surface of the toppling head such that in use the elevated pressure of the driving fluid discharged by the motor presses the piston against said slant upper surface of the toppling head thereby inducing the toppling head to pivot towards the extended position thereof.

20 25 8. The device of claim 6, wherein the hydraulic piston is slidably arranged around the flexible shaft and the flexible shaft is made of a resilient material and exerts a residual torque to the toppling head which torque induces the toppling head to pivot towards its contracted position in the absence of hydraulic pressure exerted to the piston.

30 35 9. The device of claims 4 and 7, wherein the device is suitable for milling a window in a well tubular and a cuttings collecting box is secured to the housing beneath the mills and in use the hydraulic driving fluid emerging

from the motor flushes cuttings from the mills into the cuttings collecting box.

(74)

1/2

Fig.1.

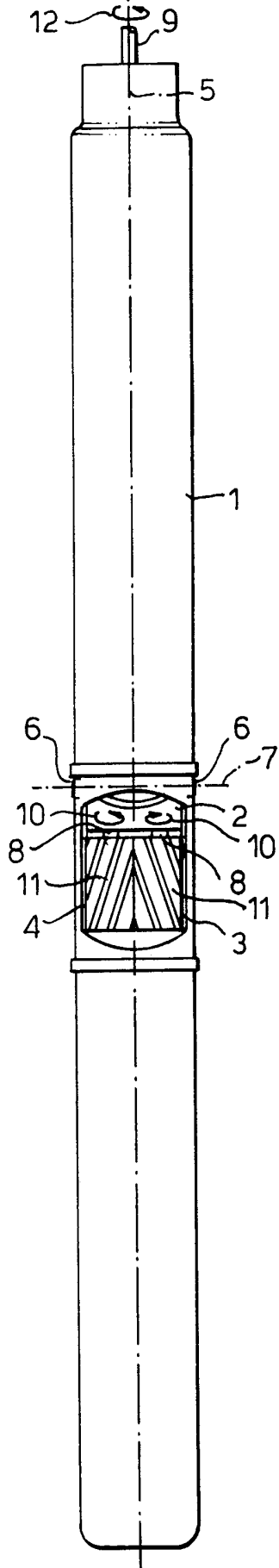

Fig.2.

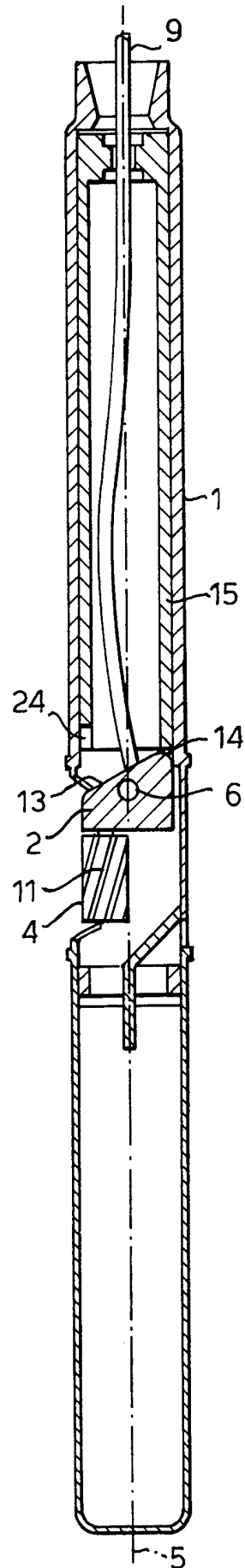

Fig.3.

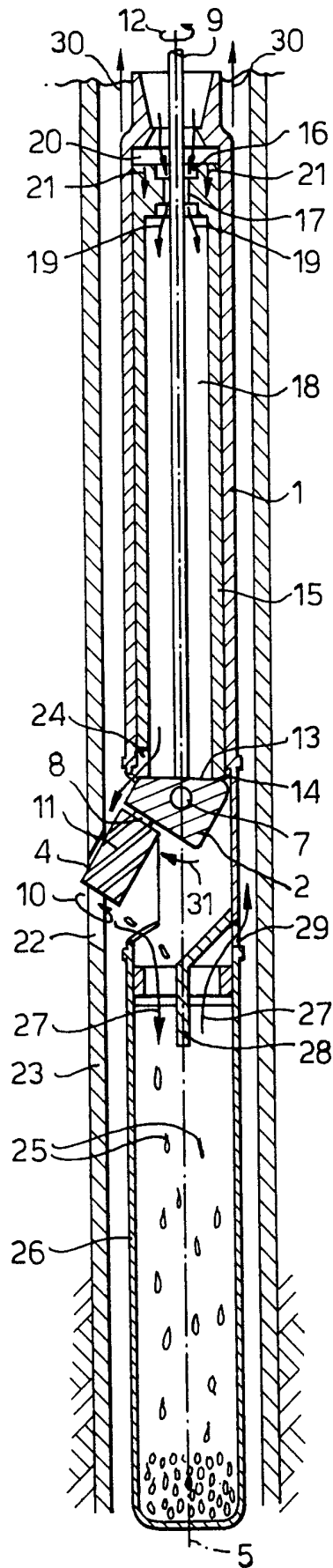
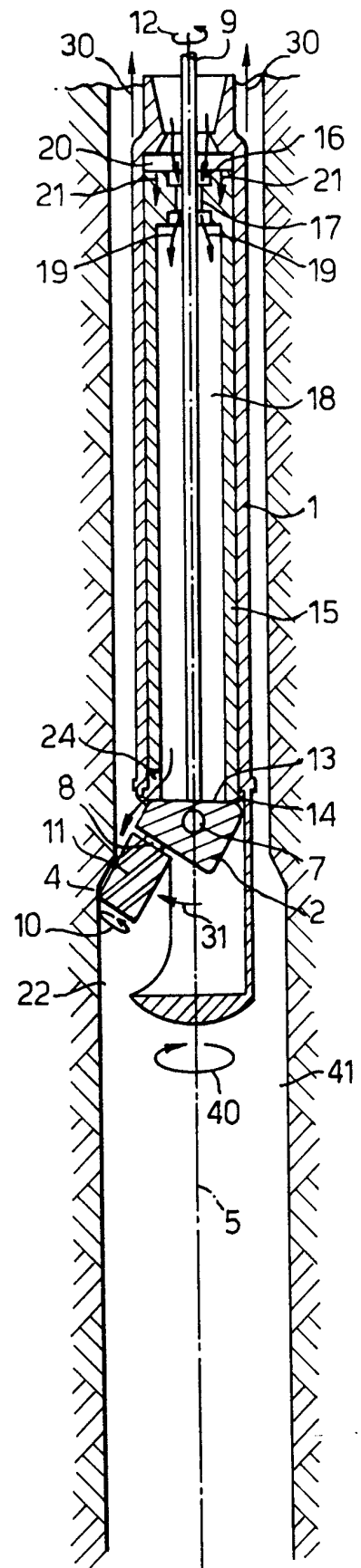

Fig.4.



INTERNATIONAL SEARCH REPORT

International Application No

PCT/EP 99/04039

A. CLASSIFICATION OF SUBJECT MATTER

IPC 6 E21B29/06 E21B27/00 E21B7/28 E21B4/16

According to International Patent Classification (IPC) or to both national classification and IPC

B. FIELDS SEARCHED

Minimum documentation searched (classification system followed by classification symbols)

IPC 6 E21B

Documentation searched other than minimum documentation to the extent that such documents are included in the fields searched

Electronic data base consulted during the international search (name of data base and, where practical, search terms used)

C. DOCUMENTS CONSIDERED TO BE RELEVANT

Category °	Citation of document, with indication, where appropriate, of the relevant passages	Relevant to claim No.
X	EP 0 798 443 A (TRACTO-TECHNIK PAUL SCHMIDT SPEZIALMASCHINEN) 1 October 1997 (1997-10-01) column 8, line 56 -column 9, line 11 ---	1-3,6
X	US 5 503 235 A (FALGOUT) 2 April 1996 (1996-04-02) abstract column 4, line 66 -column 5, line 2 ---	1,2
X	US 5 273 123 A (BARDIN) 28 December 1993 (1993-12-28) the whole document ---	1
X	US 5 056 242 A (MIOTTI) 15 October 1991 (1991-10-15) column 4, line 65 -column 5, line 1 column 5, line 9 - line 13 ---	1
	-/--	

Further documents are listed in the continuation of box C.

Patent family members are listed in annex.

° Special categories of cited documents :

- *A* document defining the general state of the art which is not considered to be of particular relevance
- *E* earlier document but published on or after the international filing date
- *L* document which may throw doubts on priority claim(s) or which is cited to establish the publication date of another citation or other special reason (as specified)
- *O* document referring to an oral disclosure, use, exhibition or other means
- *P* document published prior to the international filing date but later than the priority date claimed

- *T* later document published after the international filing date or priority date and not in conflict with the application but cited to understand the principle or theory underlying the invention
- *X* document of particular relevance; the claimed invention cannot be considered novel or cannot be considered to involve an inventive step when the document is taken alone
- *Y* document of particular relevance; the claimed invention cannot be considered to involve an inventive step when the document is combined with one or more other such documents, such combination being obvious to a person skilled in the art.
- *Z* document member of the same patent family

Date of the actual completion of the international search

25 October 1999

Date of mailing of the international search report

28 10 1999

Name and mailing address of the ISA

European Patent Office, P.B. 5818 Patentlaan 2
NL - 2280 HV Rijswijk
Tel. (+31-70) 340-2040, Tx. 31 651 epo nl,
Fax: (+31-70) 340-3016

Authorized officer

Sogno, M

INTERNATIONAL SEARCH REPORT

International Application No

PCT/EP 99/04039

C.(Continuation) DOCUMENTS CONSIDERED TO BE RELEVANT

Category °	Citation of document, with indication, where appropriate, of the relevant passages	Relevant to claim No.
X	US 1 731 553 A (VAN KEULEN) 15 October 1929 (1929-10-15) page 1, line 61 - line 72 ---	1
X	US 4 003 602 A (JUSTICE) 18 January 1977 (1977-01-18) abstract ---	1
A	GB 2 311 547 A (TIW CORPORATION) 1 October 1997 (1997-10-01) abstract page 14, line 17 - line 23 page 1, line 32 -page 2, line 4 ---	1
A	US 5 551 509 A (BRADDICK) 3 September 1996 (1996-09-03) cited in the application column 5, line 60 - line 65 column 7, line 53 - line 67 ---	1
A	GB 2 129 350 A (COLEBRAND LIMITED) 16 May 1984 (1984-05-16) abstract page 1, line 101 - line 106 ---	1
A	GB 2 306 985 A (LEDINGHAM CHALMERS TRUSTEE COMPANY LIMITED) 14 May 1997 (1997-05-14) cited in the application abstract ---	1
A	WO 96 09460 A (THE RED BARON (OIL TOOLS RENTAL) LIMITED) 28 March 1996 (1996-03-28) cited in the application abstract ---	1
A	US 4 442 908 A (STEENBOCK) 17 April 1984 (1984-04-17) abstract ---	1
A	US 4 770 255 A (BARTHELEMY) 13 September 1988 (1988-09-13) column 3, line 38 - line 42 ---	1
A	US 5 135 059 A (TURNER) 4 August 1992 (1992-08-04) abstract ---	1
X	US 5 484 029 A (EDDISON) 16 January 1996 (1996-01-16) abstract -----	1

INTERNATIONAL SEARCH REPORT

Information on patent family members

International Application No

PCT/EP 99/04039

Patent document cited in search report	Publication date	Patent family member(s)	Publication date
EP 798443 A	01-10-1997	DE 19612902 A JP 10030392 A US 5937954 A	02-10-1997 03-02-1998 17-08-1999
US 5503235 A	02-04-1996	NONE	
US 5273123 A	28-12-1993	FR 2641316 A CA 2006927 A EP 0377373 A NO 301783 B	06-07-1990 30-06-1990 11-07-1990 08-12-1997
US 5056242 A	15-10-1991	NONE	
US 1731553 A	15-10-1929	NL 23055 C	15-05-1930
US 4003602 A	18-01-1977	CA 1057317 A CA 1059538 A GB 1573418 A US 4082362 A ZA 7607603 A	26-06-1979 31-07-1979 20-08-1980 04-04-1978 30-11-1977
GB 2311547 A	01-10-1997	US 5373906 A GB 2311548 A,B CA 2135402 A,C DE 4491348 T GB 2280920 A,B WO 9420727 A	20-12-1994 01-10-1997 15-09-1994 11-05-1995 15-02-1995 15-09-1994
US 5551509 A	03-09-1996	CA 2164773 A GB 2299106 A,B GB 2324110 A,B GB 2328968 A,B US 5647436 A	25-09-1996 25-09-1996 14-10-1998 10-03-1999 15-07-1997
GB 2129350 A	16-05-1984	NONE	
GB 2306985 A	14-05-1997	NONE	
WO 9609460 A	28-03-1996	AT 167726 T AU 3529595 A CA 2199825 A DE 69503141 D EP 0781369 A GB 2305198 A,B NO 971280 A US 5911275 A	15-07-1998 09-04-1996 28-03-1996 30-07-1998 02-07-1997 02-04-1997 16-05-1997 15-06-1999
US 4442908 A	17-04-1984	DE 3107973 A AT 372498 B AT 266281 A CA 1157005 A FR 2486585 A GB 2080367 A,B IT 1138027 B NL 8103119 A,B,	11-02-1982 10-10-1983 15-02-1983 15-11-1982 15-01-1982 03-02-1982 10-09-1986 01-02-1982
US 4770255 A	13-09-1988	FR 2597543 A AU 592425 B	23-10-1987 11-01-1990

INTERNATIONAL SEARCH REPORT

Information on patent family members

International Application No

PCT/EP 99/04039

Patent document cited in search report	Publication date	Patent family member(s)	Publication date
US 4770255 A		AU 7176287 A	22-10-1987
		BR 8701830 A	26-01-1988
		CA 1273624 A	04-09-1990
		EP 0242307 A	21-10-1987
		IN 168725 A	25-05-1991
		JP 63011785 A	19-01-1988
		ZA 8702753 A	05-10-1987

US 5135059 A	04-08-1992	NONE	

US 5484029 A	16-01-1996	AU 681302 B	21-08-1997
		AU 2830095 A	15-02-1996
		EP 0695850 A	07-02-1996
		NO 953068 A	06-02-1996
		US 5529133 A	25-06-1996
		US 5617926 A	08-04-1997
