

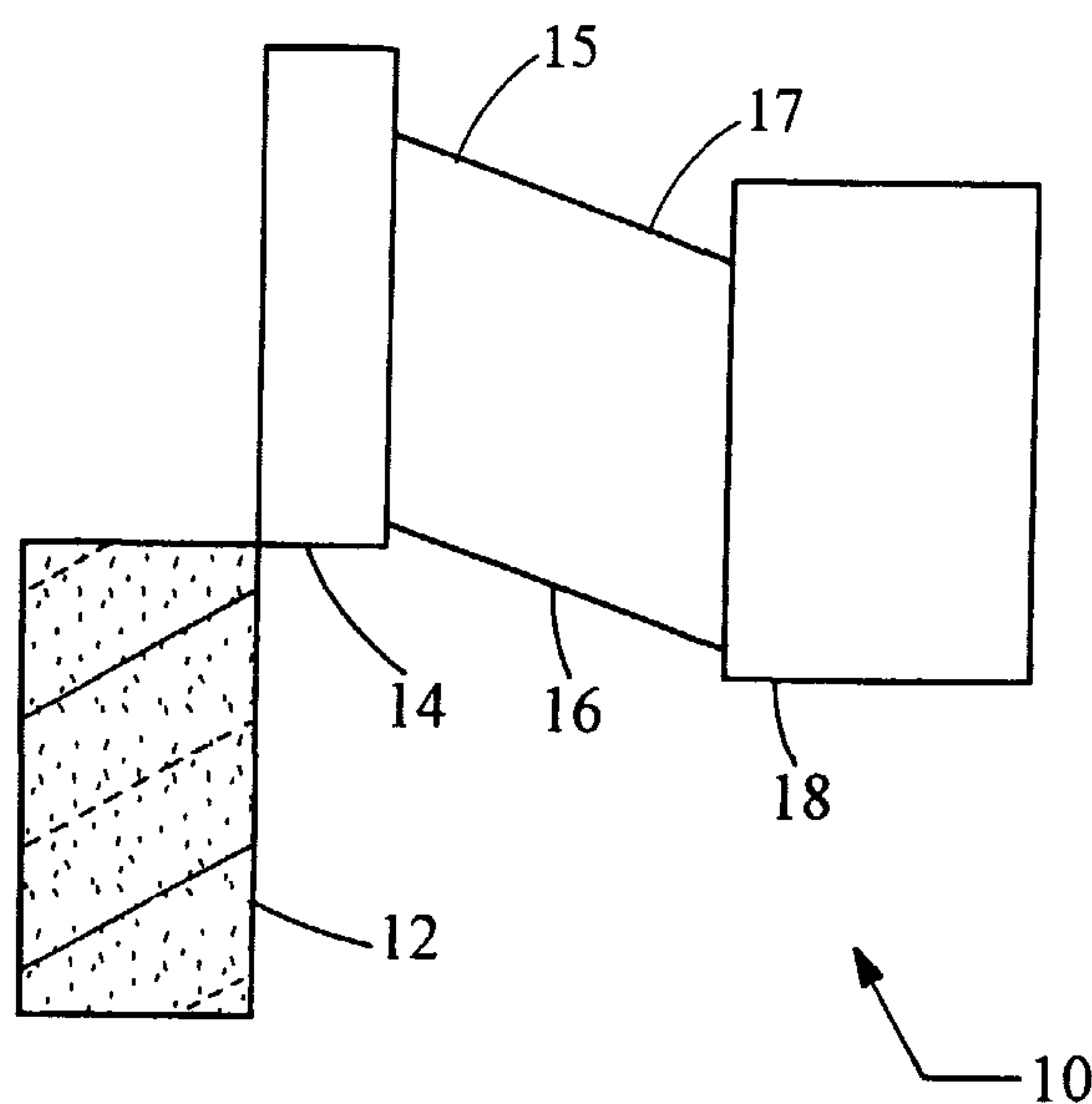

(86) Date de dépôt PCT/PCT Filing Date: 2003/02/03  
 (87) Date publication PCT/PCT Publication Date: 2003/08/07  
 (85) Entrée phase nationale/National Entry: 2004/07/26  
 (86) N° demande PCT/PCT Application No.: US 2003/003181  
 (87) N° publication PCT/PCT Publication No.: 2003/065416  
 (30) Priorité/Priority: 2002/02/01 (60/353,849) US

(51) Cl.Int.<sup>7</sup>/Int.Cl.<sup>7</sup> H01L 31/00, H01L 31/075, H01L 31/06,  
H01L 31/0328  
 (71) Demandeur/Applicant:  
PICOMETRIX, INC., US  
 (72) Inventeurs/Inventors:  
KO, CHENG C., US;  
LEVINE, BARRY, US  
 (74) Agent: MACRAE & CO.

(54) Titre : PHOTODETECTEUR AMELIORE  
 (54) Title: ENHANCED PHOTODETECTOR



(57) **Abrégé/Abstract:**

The present invention includes a photodiode (10) having a first p-type semiconductor layer (14) and an n-type semiconductor layer (18) coupled by a second p-type semiconductor layer (16). The second p-type semiconductor layer (16) has graded doping along the path of the carriers. In particular, the doping is concentration graded from a high value (15) near the anode to a lower p concentration (17) towards the cathode (22). By grading the doping in this way, an increase in absorption is achieved, improving the responsivity of the device. Although this doping increases the capacitance relative to an intrinsic semiconductor of the same thickness, the pseudo electric field that is created by the graded doping gives the electrons a very high velocity which more than compensates for this increased capacitance.

## (12) INTERNATIONAL APPLICATION PUBLISHED UNDER THE PATENT COOPERATION TREATY (PCT)

(19) World Intellectual Property  
Organization  
International Bureau



(43) International Publication Date  
7 August 2003 (07.08.2003)

PCT

(10) International Publication Number  
**WO 2003/065416 A3**

- (51) International Patent Classification<sup>7</sup>: **H01L 31/00**, 31/0328, 31/06, 31/075
- (21) International Application Number: PCT/US2003/003181
- (22) International Filing Date: 3 February 2003 (03.02.2003)
- (25) Filing Language: English
- (26) Publication Language: English
- (30) Priority Data: 60/353,849 1 February 2002 (01.02.2002) US
- (71) Applicant (for all designated States except US): **PI-COMETRIX, INC.** [US/US]; 2925 Boardwalk, Ann Arbor, MI 48104 (US).
- (72) Inventors; and
- (75) Inventors/Applicants (for US only): **KO, Cheng, C.** [US/US]; 713 Skynob Drive, Ann Arbor, MI 48105 (US). **LEVINE, Barry** [US/US]; 22 Bear Brook Lane, Livingston, NJ 07039 (US).
- (74) Agents: **KENNEDY, Ryan, B.** et al.; Brinks Hofer Gilson & Lione, P.O. Box 10087, Chicago, IL 60610 (US).
- (81) Designated States (*national*): AE, AG, AL, AM, AT, AU, AZ, BA, BB, BG, BR, BY, BZ, CA, CH, CN, CO, CR, CU, CZ, DE, DK, DM, DZ, EC, EE, ES, FI, GB, GD, GE, GH, GM, HR, HU, ID, IL, IN, IS, JP, KE, KG, KP, KR, KZ, LC, LK, LR, LS, LT, LU, LV, MA, MD, MG, MK, MN, MW, MX, MZ, NO, NZ, OM, PH, PL, PT, RO, RU, SC, SD, SE, SG, SK, SL, TJ, TM, TN, TR, TT, TZ, UA, UG, US, UZ, VC, VN, YU, ZA, ZM, ZW.
- (84) Designated States (*regional*): ARIPO patent (GH, GM, KE, LS, MW, MZ, SD, SL, SZ, TZ, UG, ZM, ZW), Eurasian patent (AM, AZ, BY, KG, KZ, MD, RU, TJ, TM), European patent (AT, BE, BG, CH, CY, CZ, DE, DK, EE, ES, FI, FR, GB, GR, HU, IE, IT, LU, MC, NL, PT, SE, SI, SK, TR), OAPI patent (BF, BJ, CF, CG, CI, CM, GA, GN, GQ, GW, ML, MR, NE, SN, TD, TG).
- Declaration under Rule 4.17:**  
— of inventorship (Rule 4.17(iv)) for US only
- Published:**  
— with international search report
- (88) Date of publication of the international search report: 11 March 2004
- For two-letter codes and other abbreviations, refer to the "Guidance Notes on Codes and Abbreviations" appearing at the beginning of each regular issue of the PCT Gazette.*

(54) Title: ENHANCED PHOTODETECTOR

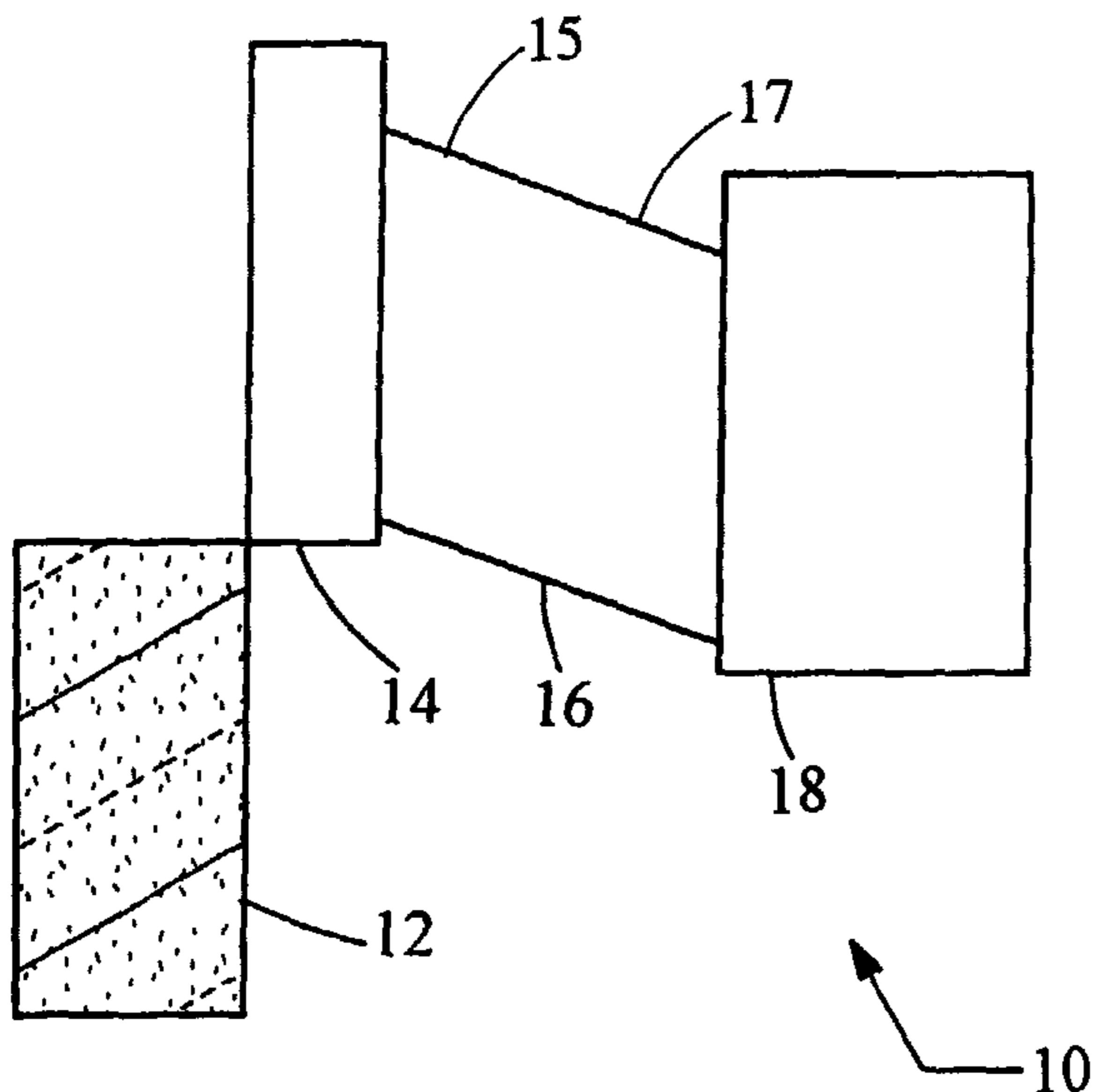

(57) Abstract: The present invention includes a photodiode (10) having a first p-type semiconductor layer (14) and an n-type semiconductor layer (18) coupled by a second p-type semiconductor layer (16). The second p-type semiconductor layer (16) has graded doping along the path of the carriers. In particular, the doping is concentration graded from a high value (15) near the anode to a lower p concentration (17) towards the cathode (22). By grading the doping in this way, an increase in absorption is achieved, improving the responsivity of the device. Although this doping increases the capacitance relative to an intrinsic semiconductor of the same thickness, the pseudo electric field that is created by the graded doping gives the electrons a very high velocity which more than compensates for this increased capacitance.

WO 2003/065416 A3

## ENHANCED PHOTODETECTOR

## FIELD OF THE INVENTION

**[0001]** The present invention relates to a semiconductor-based photodetector, and in particular to a high-speed, broad bandwidth photodetector having enhanced absorption characteristics.

## BACKGROUND AND SUMMARY OF THE INVENTION

**[0002]** There is a well-known tradeoff between high speed and sensitivity in a photodetector. High bandwidth signal detection requires a short transit time of the carriers and thus a thin absorption layer. However, the geometrical constraints on the absorption layer thickness results in a reduced absorption and lower responsivity.

**[0003]** One type of semiconductor-based photodetector is termed a p-i-n junction diode, or a PIN diode. This type of structure is generally composed of a number of solid semiconductive sandwiched together in an epitaxial structure. In particular, a p-type semiconductor material and an n-type semiconductor region are separated by an intrinsic semiconductor.

**[0004]** In a PIN diode, the depletion layer extends into each side of junction by a distance that is inversely proportional to the doping concentration. Thus, the p-i depletion layer extends well into the intrinsic material, as does the depletion layer of the i-n junction. Accordingly, a PIN diode functions like a p-n junction with a depletion layer that encompasses the entirety of the intrinsic material. The primary advantages inherent to this structure are twofold. First, the addition of the intrinsic

layer permits a fractional increase in the amount of light to be captured by the diode. Secondly, due to the extended depletion layer, the PIN diode has a very small junction capacitance and corresponding fast response.

**[0005]** Most attempts at increasing the speed of PIN diodes have focused on reducing the capacitance at the junction. At least one proposed design has included an undoped drift region for this purpose, effectively increasing the size of the intrinsic portion of the diode. Although this solution is suitable for decreasing the junction capacitance, it unfortunately increases the transit time for the carriers and thus reduces the response time of the photodetector. As such, there is a need in the art for an improved photodetector that strikes the proper balance between capacitance and response time, while increasing the responsivity of the device.

**[0006]** Accordingly, the present invention includes a photodiode having a first p-type semiconductor layer and an n-type semiconductor layer coupled by a second p-type semiconductor layer. The second p-type semiconductor layer has graded doping along the path of the carriers. In particular, the doping is concentration graded from a high value near the anode to a lower p concentration towards the cathode. By grading the doping in this way, an increase in absorption is achieved, improving the responsivity of the device. Although this doping increases the capacitance relative to an intrinsic semiconductor of the same thickness, the pseudo electric field that is created by the graded doping gives the electrons a very high velocity which more than compensates for this increased capacitance. Further embodiments and advantages of the present invention are discussed below with reference to the figures.

## BRIEF DESCRIPTION OF THE DRAWINGS

**[0007]** Figure 1 is an energy band diagram of a pin photodiode in accordance with the present invention.

**[0008]** Figure 2 is a cross-sectional view of a basic configuration of a pin photodiode in a surface illuminated structure in accordance with the present invention.

**[0009]** Figure 3 is a graph representing the relationship between the electric field and the electron velocity according to an aspect of the present invention.

**[0010]** Figure 4 is a graph representing the relationship between the doping concentration and the relative depth of a semiconductor layer of the present invention.

## DETAILED DESCRIPTION OF THE PREFERRED EMBODIMENT

**[0011]** In accordance with a preferred embodiment of the present invention, an epitaxial structure is provided for photoconductive purposes. The photoconductive structure is a modified PIN diode that is optimized for increased performance through an enhanced layer having a graded doping concentration. The particulars of the structure and method of manufacture of the present invention are discussed further herein.

**[0012]** Referring to Figure 1, an energy band diagram of a PIN photodiode 10 shows the relative energy levels of the semiconductor materials that form the photodiode 10. In particular, the photodiode 10 is comprised of a group of semiconductor materials, including a first p-type semiconductor layer 14, a second p-type semiconductor layer 16, and an n-type semiconductor layer 18. An anode layer 12 is shown adjacent to the first p-type semiconductor layer 14 to collect holes.

**[0013]** The first p-type semiconductor layer 14 is selected from a group comprising tertiary semiconductors, or group III-V semiconductors. Accordingly, the first p-type semiconductor layer 14 is either two elements from group III combined with one element from group V or the converse, two elements from group V combined with one element from group III. A table of representative groups of the periodic table is shown below.

GROUP II	GROUP III	GROUP IV	GROUP V
Zinc (Zn)	Aluminum (Al)	Silicon (Si)	Phosphorus (P)
Cadmium (Cd)	Gallium (Ga)	Germanium (Ge)	Arsenic (As)
Mercury (Hg)	Indium (In)		Antimony (Sb)

**[0014]** In the preferred embodiment, the first p-type semiconductor layer 14 is InAlAs. However, it is understood that the first p-type semiconductor layer 14 may be any tertiary semiconductor that provides the necessary bandgap for optimized operation of the photodiode 10.

**[0015]** The n-type semiconductor layer 18 is also selected from a group comprising tertiary semiconductors, or group III-V semiconductors. As before, the n-type semiconductor layer 18 is either two elements from group III combined with one element from group V or the converse, two elements from group V combined with one element from group III. In the preferred embodiment, the n-type semiconductor layer 18 is InAlAs. However, it is understood that the n-type semiconductor layer 18 may be any tertiary semiconductor that provides the necessary bandgap for optimized operation of the photodiode 10.

**[0016]** The second p-type semiconductor layer 16 is also selected from a group comprising tertiary semiconductors, or group III-V semiconductors. In the

preferred embodiment, the second p-type semiconductor layer 16 is InGaAs with a graded doping concentration. However, it is understood that the second p-type semiconductor layer 16 may be any tertiary semiconductor that provides the necessary low bandgap for optimized operation of the photodiode 10.

**[0017]** In order to achieve a graded doping concentration, the second p-type semiconductor layer 16 is not doped in a typical manner. In general, a p-type semiconductor is fabricated by using dopants with a deficiency of valence electrons, also known as acceptors. The p-type doping results in an abundance of holes. For example, in a type III-V semiconductor, some of the group III atoms may be replaced with atoms from group II, such as Zn or Cd, thereby producing a p-type material. Similarly, as group IV atoms act as acceptors for group V atoms and donors for group III atoms, a group IV doped III-V semiconductor will have an excess of both electrons and holes.

**[0018]** Figure 2 is a cross-sectional view of a basic configuration of a photodiode 10 in a surface illuminated structure designed in accordance with the present invention. A substrate layer 20 is provided for growing the semiconductor structure. The n-type semiconductor layer 18 is deposited upon the substrate. The first p-type semiconductor layer 14 and the second p-type semiconductor layer 16 are deposited in a manner such that the second p-type semiconductor layer 16 is directly adjacent to the n-type semiconductor layer 18. As before, an anode layer 12 is deposited on the first p-type semiconductor layer 14 for collecting holes. Also shown is a cathode layer 22, or n-type contact layer, for collecting electrons.

**[0019]** As noted, it is a feature of the second p-type semiconductor layer 16 that it includes a graded doping concentration. The presence of dopants in the

second p-type semiconductor layer 16 is controlled in order to optimize the performance of the photodiode. A first concentration 15 is located near the first p-type semiconductor 14, and a second concentration 17 is directly adjacent to the n-type semiconductor 18. Preferably, the first concentration 15 is between 800 and 1,000 angstroms deep, i.e. the dimension parallel to the travel of the carriers.

**[0020]** In the preferred embodiment, the first concentration 15 is greater than the second concentration 17. In particular, the first concentration 15 is located at a position  $x_0$  and defines a dopant concentration  $p_0$ . A preferred doping concentration gradient is governed by the following equation:

$$(1) \quad p = p_0 e^{\frac{-x}{D}}$$

over the depth D of the second p-type semiconductor layer 16 for all x and D greater than zero. A graph representative of Equation (1) is shown in Figure 4.

**[0021]** The graded doping structure of the second p-type semiconductor layer 16 results in improved performance of the photodiode 10. During operation, incident light is absorbed in the second p-type semiconductor layer 16 of the photodiode 10. The light that is absorbed in the second concentration 17 part of the second p-type semiconductor layer 16 produces electrons and holes which drift to the anode 12 and cathode 22 under the influence of the large drift electric field. Although this is the usual situation in standard uniformly low doped absorber PIN photodetectors, in the present invention, the photoresponse of the carriers is more complex.

**[0022]** The electrons generated in the second concentration 17 part of the second p-type semiconductor layer 16 reach the cathode with their saturation velocity and are collected. The holes generated in the second concentration 17 part

of the second p-type semiconductor layer 16 travel to the anode 12, thus entering the first concentration 15 where the concentration of dopants is relatively high and where they are collected, thus ending their transit time.

**[0023]** By way of comparison, the light that is absorbed in the first concentration 15 part of the second p-type semiconductor layer 16 also produces electrons and holes. In this case however, the holes are readily collected in the first concentration 15 and thus do not add substantially to the transit time of the carriers or reduce the bandwidth of the photodiode 10. Accordingly, insofar as the holes are concerned, the graded doping concentration of the photodiode 10 does not add to their transit time or reduce the detector bandwidth in either in the first concentration 15 or the second concentration 17.

**[0024]** Another aspect of the graded doping concentration of the second p-type semiconductor layer 16 is the creation of a pseudo-electric field. The electrons generated in the first concentration 15 region are subject to this pseudo-field shown below as

$$(2) \quad E = -\left(\frac{kT}{q}\right)\frac{dp}{dx},$$

where k is Boltzman's constant, T is the temperature, q is the charge of an electron, and the value  $\frac{dp}{dx}$  is the doping concentration gradient.

**[0025]** The pseudo-field E produces an "overshoot" electron velocity, i.e. the electron velocity is potentially many times faster than the saturation velocity. A typical electron saturation velocity is on the order of  $5 \times 10^6$  cm/sec. However, the exponential gradient shown in Equation (1) with  $D=1,000$  angstroms yields a field  $E=2.5$  kV/cm, which corresponds to an electron overshoot velocity as large as  $3 \times 10^7$

cm/sec. A graph depicting the relationship between the magnitude of the pseudo-field  $E$  and the electron velocity is shown in Figure 3.

**[0026]** As described, the present invention improves upon the state of the art in photodiodes by implementing a graded doping concentration. In such a manner, the net absorption of a photodiode can be increased without substantially reducing the overall bandwidth of the device. It is further understood that it may be advantageous to optimize the overall speed by adjusting the doping concentration, the capacitance of the device, and the total thickness of the absorption region. It should be apparent to those skilled in the art that the above-described embodiments are merely illustrative of but a few of the many possible specific embodiments of the present invention. Numerous and various other arrangements can be readily devised by those skilled in the art without departing from the spirit and scope of the invention as defined in the following claims.

## CLAIMS

1. A photodiode comprising:
  - a first p-type semiconductor layer;
  - an n-type semiconductor layer;
  - a second p-type semiconductor layer disposed between the first p-type semiconductor layer and the n-type semiconductor layer such that the second p-type semiconductor is directly adjacent to the n-type semiconductor, the second p-type semiconductor layer having a graded doping concentration.
2. The photodiode of claim 1 further comprising an anode layer for collecting holes.
3. The photodiode of claim 1 further comprising a cathode layer for collecting electrons.
4. The photodiode of claim 1 wherein the first p-type semiconductor layer is InAlAs.
5. The photodiode of claim 1 wherein the n-type semiconductor layer is InAlAs.
6. The photodiode of claim 1 wherein the second p-type semiconductor layer is InGaAs.
7. The photodiode of claim 1 wherein the graded doping concentration defines a first concentration adjacent to the first p-type semiconductor layer and a second concentration adjacent to the n-type semiconductor layer, and further wherein the first concentration is greater than the second concentration.

8. The photodiode of claim 7 wherein the first concentration is located at a position  $x_0$  and defines a concentration  $p_0$ , and further wherein the graded doping concentration is governed by the following equation:

$$p = p_0 e^{\frac{-x}{D}}$$

over the depth  $D$  of the second p-type semiconductor layer for all  $x$  and  $D$  greater than zero.

9. The photodiode of claim 8 wherein the first concentration is between 800 and 1000 angstroms in length.

10. A method of fabricating a photodiode comprising the steps of:  
providing a substrate layer;  
depositing a first p-type semiconductor layer on the substrate;  
depositing an n-type semiconductor layer on the substrate;  
grading a second p-type semiconductor layer from a first concentration to a second concentration, wherein the first concentration is greater than the second concentration; and  
depositing the second p-type semiconductor layer between the first p-type semiconductor layer and the n-type semiconductor layer such that the second concentration is directly adjacent to the n-type semiconductor layer.

11. The method of claim 10 further comprising the step of affixing an anode to collect holes.

12. The method of claim 10 further comprising the step of affixing a cathode to collect electrons.

13. The method of claim 10 wherein the first p-type semiconductor layer is InAlAs.

14. The method of claim 10 wherein the n-type semiconductor layer is InAlAs.

15. The method of claim 10 wherein the second p-type semiconductor layer is InGaAs.

16. The method of claim 10 wherein the first concentration is located at a position  $x_0$  and defines a concentration  $p_0$ , and further wherein the graded doping concentration is governed by the following equation:

$$p = p_0 e^{\frac{-x}{D}}$$

over the depth D of the second p-type semiconductor layer for all x and D greater than zero.

17. A photodiode having a first p-type semiconductor layer and an n-type semiconductor layer comprising:

a second p-type semiconductor layer disposed between the first p-type semiconductor layer and the n-type semiconductor layer such that the second p-type semiconductor is directly adjacent to the n-type semiconductor, the second p-type semiconductor layer having a graded doping concentration, wherein the graded doping concentration is governed by the following equation:

$$p = p_0 e^{\frac{-x}{D}}$$

over the depth D of the second p-type semiconductor layer for all x and D greater than zero.

18. The photodiode of claim 17 wherein the second p-type semiconductor layer is a type III-V semiconductor.

19. The photodiode of claim 17 wherein the second p-type semiconductor layer is InGaAs.

1/2

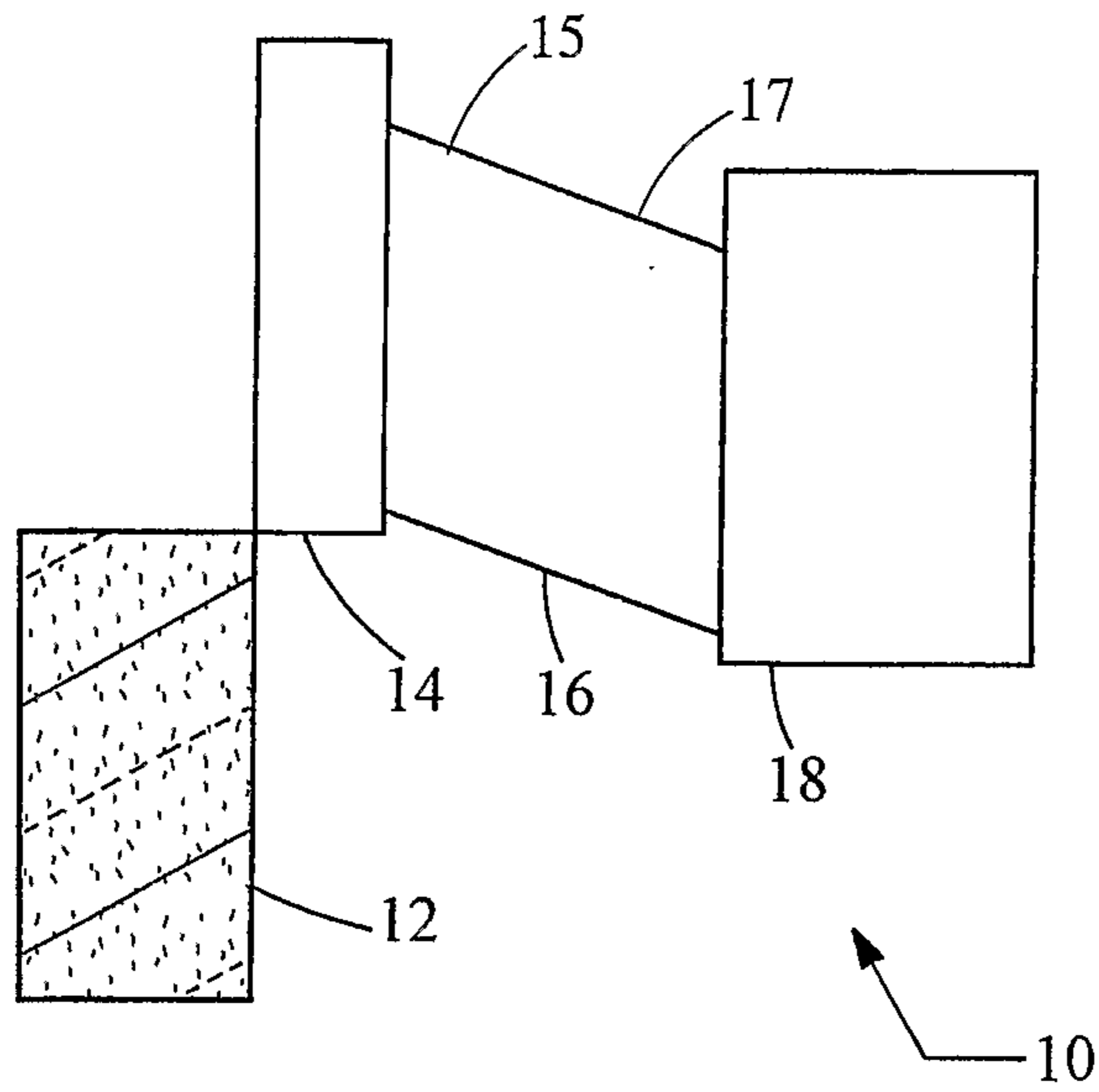

Fig. 1

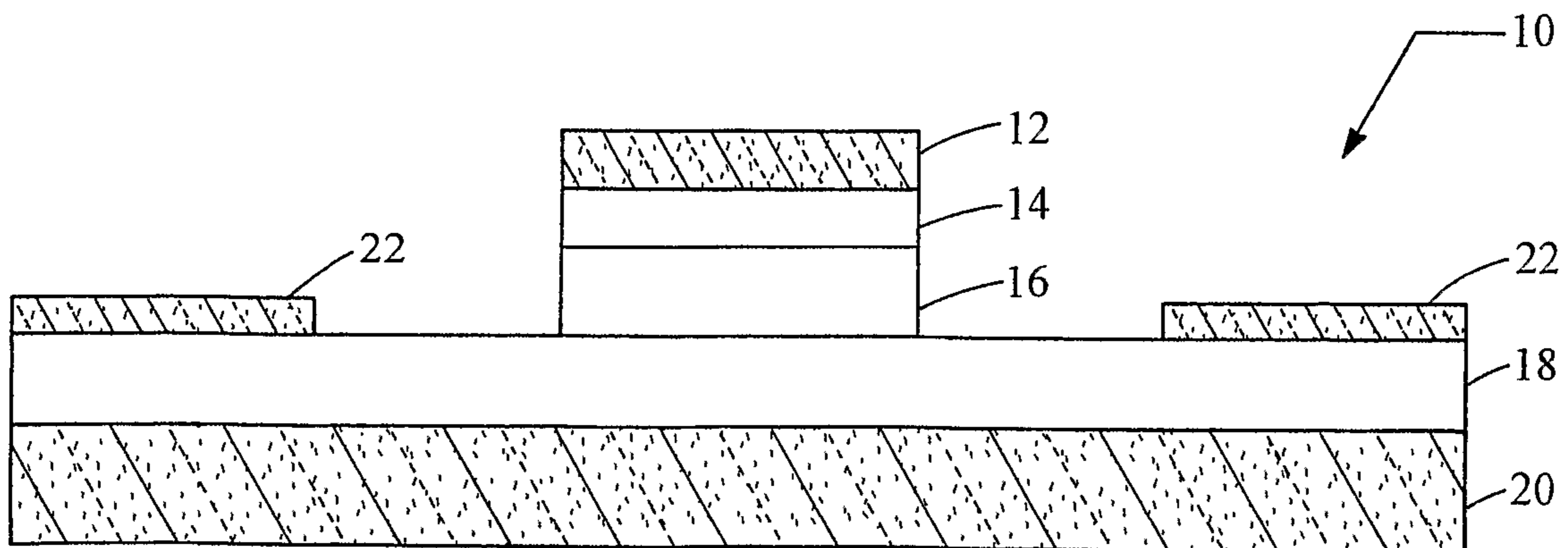

Fig. 2

2/2

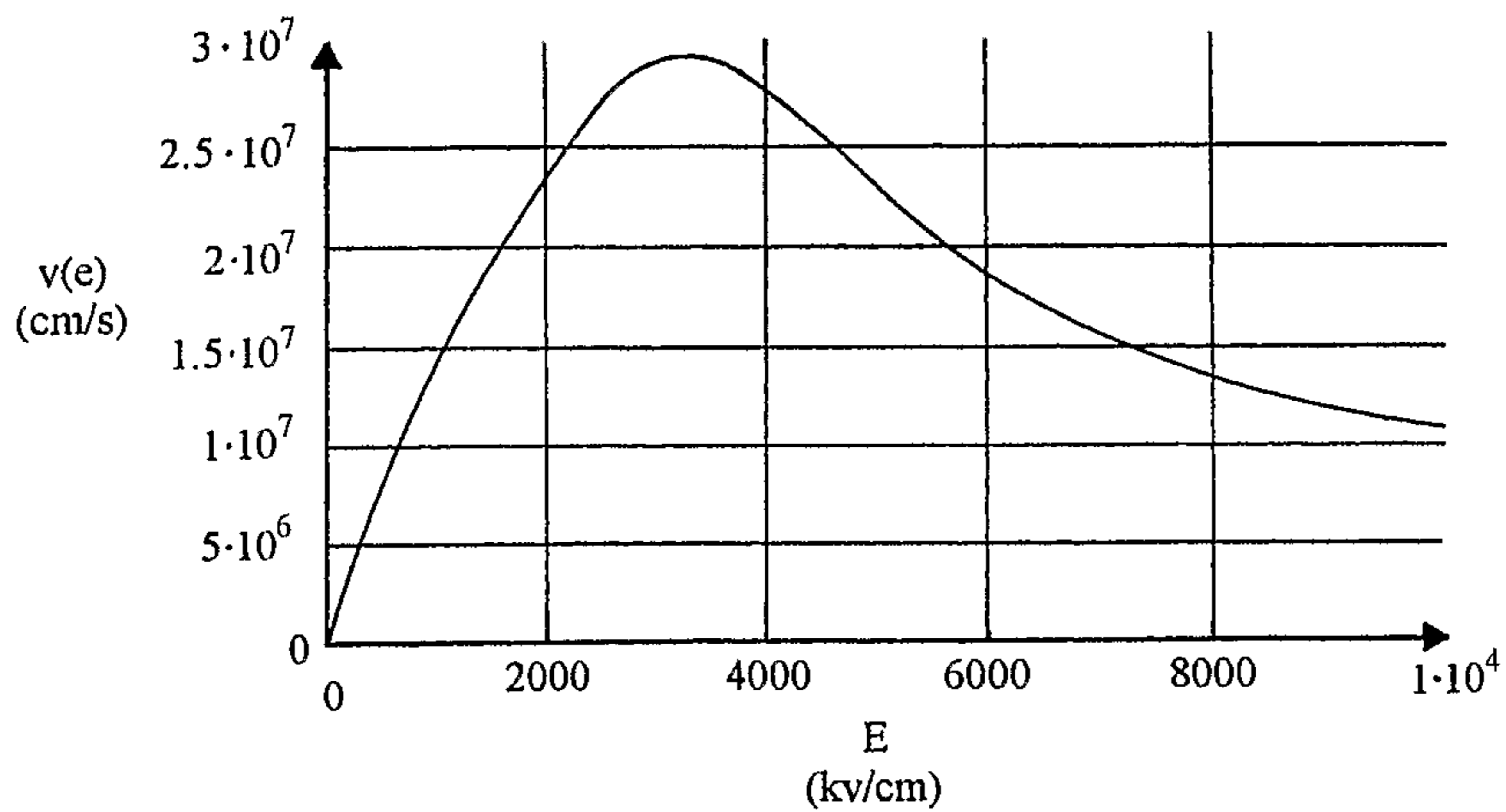

Fig. 3

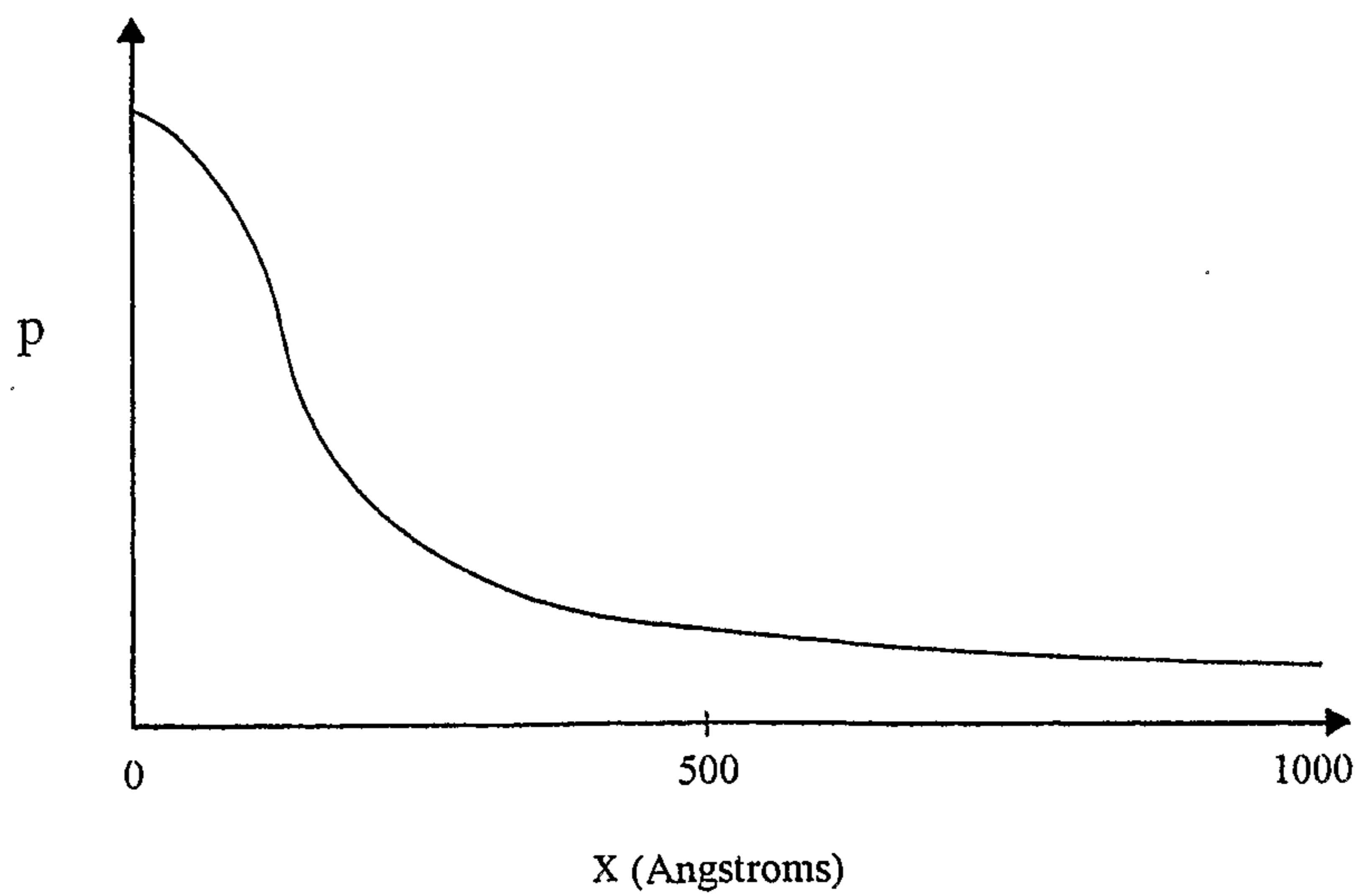

Fig. 4

