

April 19, 1966

M. I. GLASS ET AL

3,246,423

TOY TELEPHONE AND CARROUSEL

Filed Feb. 25, 1963

2 Sheets-Sheet 1

Fig. 1

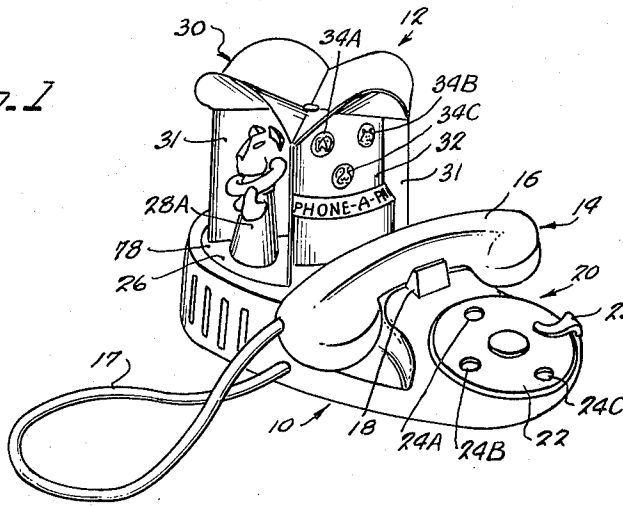

Fig. 2

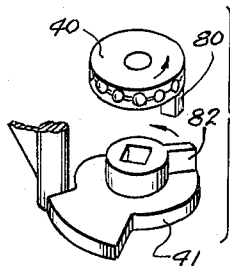
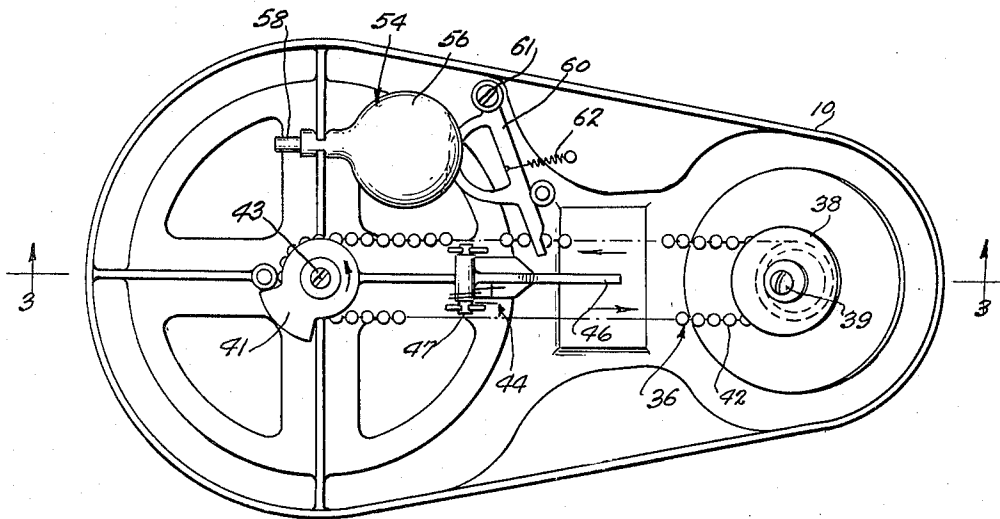

Fig. 3

Inventors
 MARVIN I. GLASS.
 GASTON J. DEMEYER.
 By JEROME L. PINSLER.
 Anderson, Luckner, Oehl, Even & Tabin
 ATTYS

April 19, 1966

M. I. GLASS ET AL

3,246,423

TOY TELEPHONE AND CARROUSEL

Filed Feb. 25, 1963

2 Sheets-Sheet 2

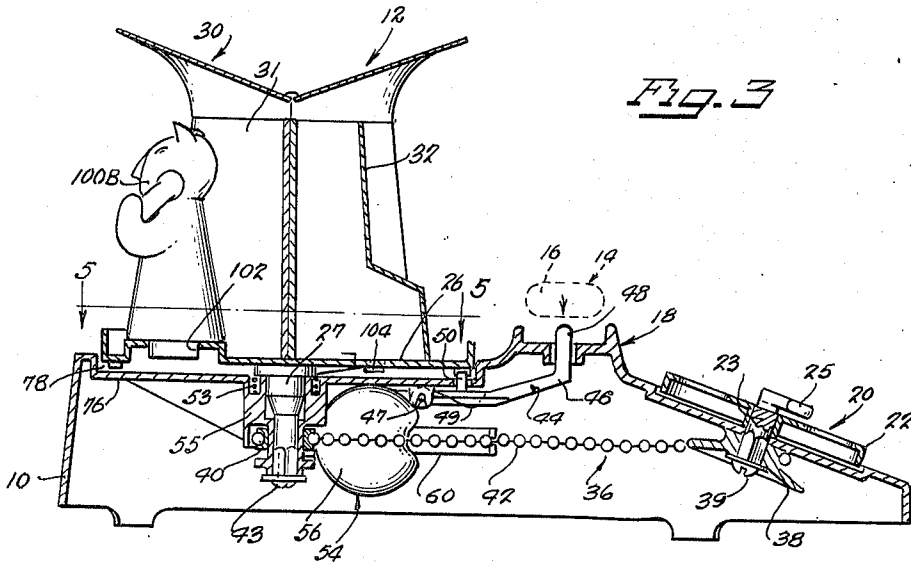

Fig. 3

Fig. 4

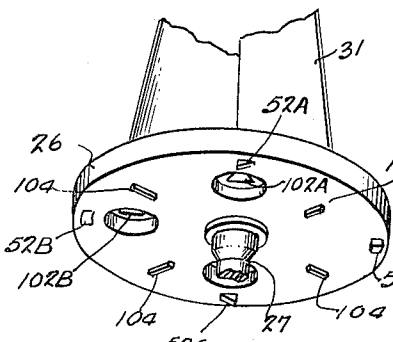

Fig. 6

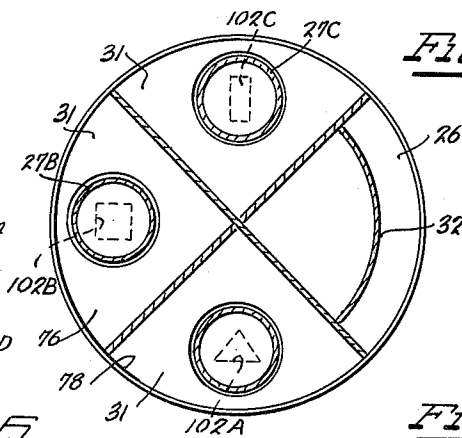

Fig. 5

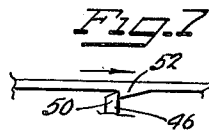
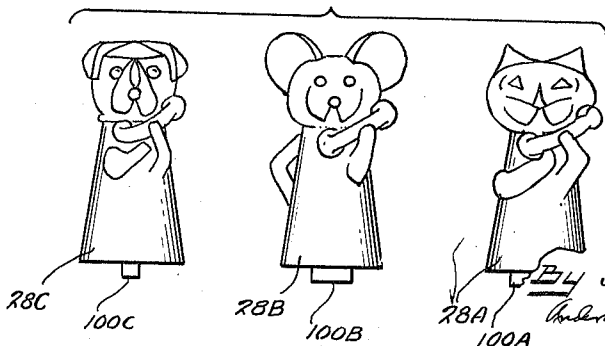

Fig. 7



Inventor
 MARVIN I. GLASS
 GASTON J. DEMEYER
 JEROME L. PINSLER
 By Anderson, Suedeker, Ditch, Egan & Tabin
 Attys

1

3,246,423

TOY TELEPHONE AND CARROUSEL

Marvin I. Glass, Gaston J. Demeyer, and Jerome L. Pinsler, Chicago, Ill., assignors to Marvin Glass & Associates, Chicago, Ill., a partnership

Filed Feb. 25, 1963, Ser. No. 260,731

1 Claim. (Cl. 46—33)

This invention relates to a toy and, more particularly, an amusing and educational toy telephone.

Various forms of common household appliances and equipment are often copied in toys which are intended to amuse and familiarize a child with the adult environment about him. For example, toy telephones of various types are well known in the toy trade and many closely simulate a typical telephone. However, such close duplication alone in a toy telephone does not provide features which adequately retain a small child's interest, simply because it does very little which is in any way amusing or particularly interesting.

It is therefore, the primary object of this invention to provide a new and amusing toy. Another object is to provide a new and amusing toy telephone in combination with toy figures which appear when they are "phoned."

A more specific object is provision of a new and amusing educational toy in the form of a carrousel and telephone, wherein the carrousel includes a plurality of toy animals and a directory with entries corresponding to each of the figures, the telephone having a dial with indices corresponding to each entry in the directory and upon operation of the dial the carrousel rotates to present the animal figure corresponding to the "number" dialed.

These and other objects of the invention are more particularly set forth in the following detailed description and in the accompanying drawings of which:

FIGURE 1 is a perspective view of a preferred embodiment of the invention in the form of a toy telephone;

FIGURE 2 is an enlarged bottom plan view of the toy shown in FIGURE 1;

FIGURE 3 is a vertical sectional view taken generally along the line 3—3 in FIGURE 2;

FIGURE 4 is an enlarged, fragmentary perspective view showing a part of a carrousel removed from the toy;

FIGURE 5 is a horizontal sectional view taken generally along the line 5—5 in FIGURE 3;

FIGURE 6 is a composite view of animal figures removed from the carrousel;

FIGURE 7 is a fragmentary view of a holding mechanism forming part of the toy; and

FIGURE 8 (Sheet 1) is an enlarged, exploded perspective view of a portion of a drive mechanism forming part of the toy.

The illustrated embodiment of the invention is directed to a toy in the form of a telephone wherein a base 10 mounts a carrousel 12 and a telephone 14. The various parts of the toy are preferably of a suitable plastic material. The telephone 14 includes a hand piece 16 connected by a cord 17 with the base 10, and removably nested in a cradle 18 forming part of the base 10. The telephone 14 further includes a dial assembly 20, including a dial 22 formed integrally with a depending stub 23 (FIGURE 3) journaled in an upper wall of the base 10 and having a plurality of indices 24A, 24B and 24C, each in the form of a hole in the dial, in keeping with common telephone structure. Upon inserting a finger into any one of the index holes and rotating the dial 22, any one of the indices may be moved from a normal position, as shown in FIGURE 1, to an indexed position against a conventional finger stop 25 extending upwardly from the base 10 and overlying the dial 22. Thus, a

2

child can manipulate the telephone 14 in a manner similar to operation of a conventional dial telephone.

The carrousel 12 includes a bed 26 having a depending stub 27 (FIGURE 3) rotatably mounting the bed on the base 10. The bed removably mounts a plurality of animal figures 28, and more particularly a cat 28A, a mouse 28B and a dog 28C, each normally concealed from the front of the telephone 14 by a canopy assembly 30 having outwardly opening V-shaped compartments 31, one receiving each of the figures 28 and a directory 32 normally facing the telephone 14. The directory 32 has a plurality of directory entries 34, each in a distinctive color and including a face of one of the figures, and more particularly an entry 34A corresponding to the cat figure 28A, an entry 34B corresponding to the mouse figure 28B, and an entry 34C corresponding to the dog figure 28C. The dial indices 24A, 24B and 24C, are distinctively colored to correspond to the colors of the directory entries 34A, 34B and 34C, respectively, and thus each index is related to but one of the animal figures 28.

Actuating means is provided for operating the carrousel 12 responsive to operation of the dial 22, and herein includes a drive mechanism 36 (FIGURES 2 and 3) including a dial pulley 38 fixedly mounted on the dial stub 23 and held thereon by a bolt and washer 39 for rotation with the dial 22, and a carrousel pulley 40 mounted on the carrousel stub 27 and engaging a driver 41 non-rotatable on the stub 27 for rotating the carrousel 12, as well be more fully described, the pulleys being operatively connected by a drive chain 42. The carrousel pulley 40 and driver 41 are retained on the stub by a suitable washer and bolt 43 threaded into the bottom of the stub. When any one of indices, for example the index 24A is rotated to indexed position at the stop 25, the cat figure 28A is rotated from its effectively concealed normal position to a prominent indexed position facing the telephone 14, or stated differently to the position normally occupied by the directory 32.

Holding means for retaining the figures 28 in their respective indexed position upon operation of the dial 22 is provided in the form of a latch assembly 44, as may best be seen in FIGURES 2-4 and 7. Herein this means is in the form of a latch lever 46 mounted on the base 10 by means of pins 47 for pivoting about a horizontal axis, and having a finger 48 extending from an end upwardly through the cradle 18. The finger 48 is normally depressed by the weight of the hand piece 16 in keeping with conventional telephone structure. With the hand piece 16 removed from the cradle 18, the latch lever 46 is urged upwardly by a suitable spring 49 about the pivot pins 47 and having opposite free ends seated against the lever 46 and the base 10. The lever 46 has an upstanding keeper 50, and when the hand piece 16 is removed from the cradle 18, the spring 49 urges the lever upwardly so that the keeper engages one of four lugs 52 depending from the carrousel bed 26, and more particularly a lug 52A adjacent the cat figure 28A, a lug 52B adjacent the mouse figure 28B, a lug 52C adjacent the dog figure 28C, and a lug 52D adjacent the directory 32. When the dial 22 is released and the hand piece 16 is nested in the cradle 18 thus depressing the lever 46, the keeper 50 is moved downwardly from the lugs 52 and the carrousel 12 moves to its normal position with the directory 32 facing the telephone 14. The return of the carrousel 12 is achieved by a spring 53 (FIGURE 3) which is coiled around the upper part of shaft 27, with one end fixed to a boss 55 providing the journal for the shaft 27 and the other end of spring 53 being bent upwardly to fixedly engage the carrousel bed 26. Thus, as the dial 22 is operated, spring 53 is ten-

sioned and retained in tension as one of lugs 52A, 52B or 52C is engaged by keeper 50 on the lever 46. As the latter is depressed by replacing the telephone on its cradle, the spring 53 serves to rotate shaft 27 and the carrousel back to its normal position as seen in FIGURE 1.

In order to further hold a child's interest in the toy, noisemaker means is provided in the form a whistle device 54 including an air bulb 56 operatively communicating with a one-way whistle 58 so that as the air bulb 56 expands the whistle emits a suitable squeaking sound. Operation of the whistle is provided by an arm 60 pivoted on the base 10 as by means of a vertical bolt 61. The arm 60 has a bifurcated end interlocked with the drive chain 42 for pivoting the arm and compressing the air bulb 56 as the dial 22 is rotated from its normal position to an indexed position, thus moving the chain. Upon releasing the dial, a tension spring 62 connected with the base 10 and the arm 60 urges the arm back to its original position thus permitting the air bulb 56 to expand and actuate the one-way whistle 58, and to return the dial 22 to its normal position with the carrousel 12 retained in its indexed position until the hand piece 16 is returned to the cradle 18.

As may best be seen in FIGURES 2-4 and 8, the carrousel stub 27 is journaled in the boss 55 depending from a bottom wall 76 of an upwardly opening cup 78 formed in the base 10 and receiving the bed 26. The carrousel pulley 40 has a depending finger 80 (FIGURE 8) positioned to engage an upstanding finger 82 on the driver 41 and as the pulley 40 is rotated responsive to the dial 22 being rotated to an indexed position of one of the indices 24, the carrousel pulley finger 80 abuts the driver finger 82 to rotate the driver and thus rotate the carrousel and move the appropriate figure 24 into position facing the telephone 14. Upon releasing the dial, as the pivoted arm 60 moves the chain 42 and the carrousel pulley 40 on the stub 27, the carrousel pulley finger 80 moves away from the driver finger 82 with the carrousel 12 retained in its indexed position. The carrousel is returned to its normal position by the spring 53, as described above.

The animal figures 28 are each removably mounted on the carrousel bed 27 by means of a depending boss 100 on each animal which can be received only in a complementary opening 102 in the bed 26. More particularly, each animal figure 28 has a depending boss of a shape different than the bosses of the other animal figures. In the illustrated embodiment, the cat 28A has a triangular boss 100A received in a triangular opening 102A, the mouse 28B has a square boss 100B received of a square opening 102B, and the dog 28C has a rectangular boss 100C received in a rectangular opening 102C. Thus, the animals can only be positioned on the carrousel bed 26 in their assigned positions. In order to facilitate removal and replacement of the animal figures, the carrousel canopy 30 may be removably mounted on the bed 26 as by depending lugs 104 received in cooperating holes in the bed 26, as may best be seen in FIGURE 3.

To summarize the operation of the toy, with the telephone 14 in its normal position, as shown in FIGURE 1, a child lifts the hand piece 16 from its cradle 18, thereby releasing the latch lever 46, and upon referring to the directory 32 determines the color code for the animal figure 28 he desires to call. Having determined this color code, the child then refers to the dial 22 and selects the corresponding color code of the appropriate index 24. By inserting a finger in the proper index hole, the dial 22 may be rotated until the finger engages the finger stop 26 on the base 10.

This operation is generally in keeping with normal telephone operation, but is adapted to the ability of the child. The child refers to the directory and by recognition of the animal face selects the corresponding directory color code which is then applied in dialing the animal figure desired.

As the dial 22 is rotated, the carrousel 12 also turns because of its driven connection with the dial 22, and moves the appropriate animal figure 28 from a relatively concealed position to a prominent indexed position facing the telephone 14. The dial 22 may now be released and the latch lever keeper 50 engages the appropriate lug 52 depending from the carrousel bed 27 to retain the appropriate animal figure 28 in the indexed position until the hand piece 16 is again placed in its cradle 18 depressing the lever finger 48 to release the keeper 50 from holding engagement with the lug 52, whereupon the carrousel 12 rotates back to its normal position with the directory 32 facing the telephone 14 as shown in FIGURE 1.

Thus, the toy is amusing to the child because he may watch the carrousel 12, and more particularly its animal figures 28 rotate and become positioned before him as he rotates the dial 22. The toy is instructive in that it accurately portrays to the child the operation of a dial telephone and further familiarizes the child with proper use of a directory and causes the child to relate the face representations on the directory entries 34 to a particular color code which he then applies in dialing the animal which then appears before him. To further enhance interest in the toy, the animals may be removed from the carrousel bed and replaced only in their original position.

While this invention has been described with particular reference to certain features and structure in a particular environment, various changes may be apparent to one skilled in the art, and the invention is not to be limited to such features, structure or environment. Various of the features of the invention are set forth in the following claim.

What is claimed is:

A toy telephone comprising a base, a carrousel rotatably mounted on said base for movement about a vertical axis, a plurality of circumferentially spaced locations on said carrousel, a plurality of different figures, complementary means on said figures and at said locations whereby a particular figure can be mounted only at a particular one of said locations, said carrousel including vertical wall portions defining separate compartments for each of said figures opening toward the periphery of said carrousel, a directory disposed in one of said compartments and comprising illustrations of the several figures, a toy telephone on said base in spaced relation to said carrousel and including a cradle, a hand piece removably supported in said cradle, and a dial with a plurality of indices each visually related to one of the directory illustrations, said carrousel being normally positioned with said directory facing said dial, said dial being mounted on said base for rotation relative to an indexed position, means connecting said dial with said carrousel for rotating the latter in response to rotation of said dial so that movement of any one of said indices to said indexed position moves the carrousel to place the related figure in facing relation to said dial, means for releasably holding said carrousel in position after one of said indices has been moved to said indexed position and additional means for returning said carrousel to its normal position in response to placement of said hand piece on said cradle.

References Cited by the Examiner

UNITED STATES PATENTS

2,066,064	12/1936	Bregman	46—33
2,110,380	3/1938	Lohr	46—33
2,110,381	3/1938	Lohr	46—33
2,747,297	5/1956	Zalkind	46—1 X
2,846,223	8/1958	Nelson	272—31

FOREIGN PATENTS

562,014 8/1923 France.

RICHARD C. PINKHAM, *Primary Examiner.*