

May 16, 1961

J. KAUFMAN

2,984,739

LIGHTING FIXTURE ASSEMBLY

Filed May 15, 1958

2 Sheets-Sheet 1

Fig. 1.

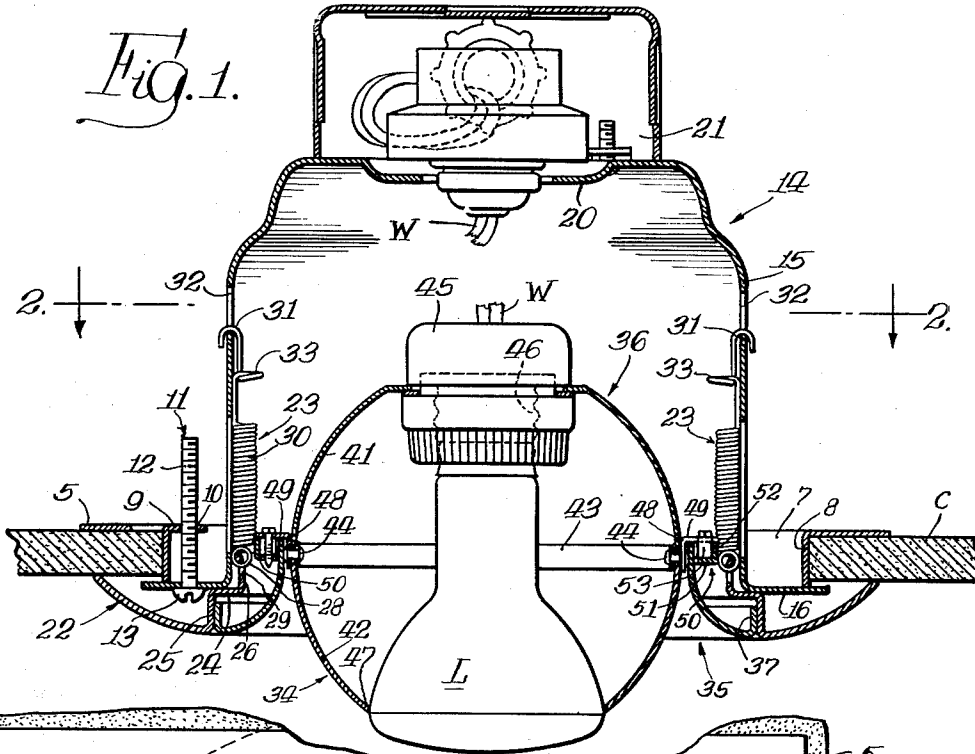
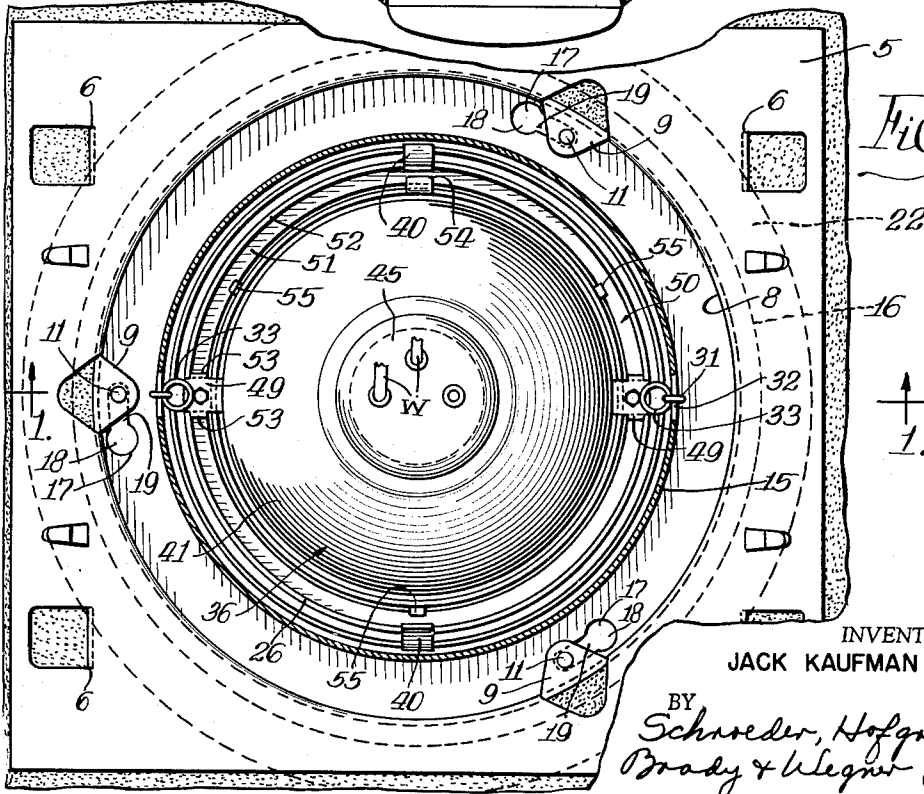

Fig. 2.



INVENTORS.  
JACK KAUFMAN  
BY  
*Schneider, Hofgren,  
Brady & Wiegner Attys.*

May 16, 1961

J. KAUFMAN

2,984,739

LIGHTING FIXTURE ASSEMBLY

Filed May 15, 1958

2 Sheets-Sheet 2

Fig. 3.

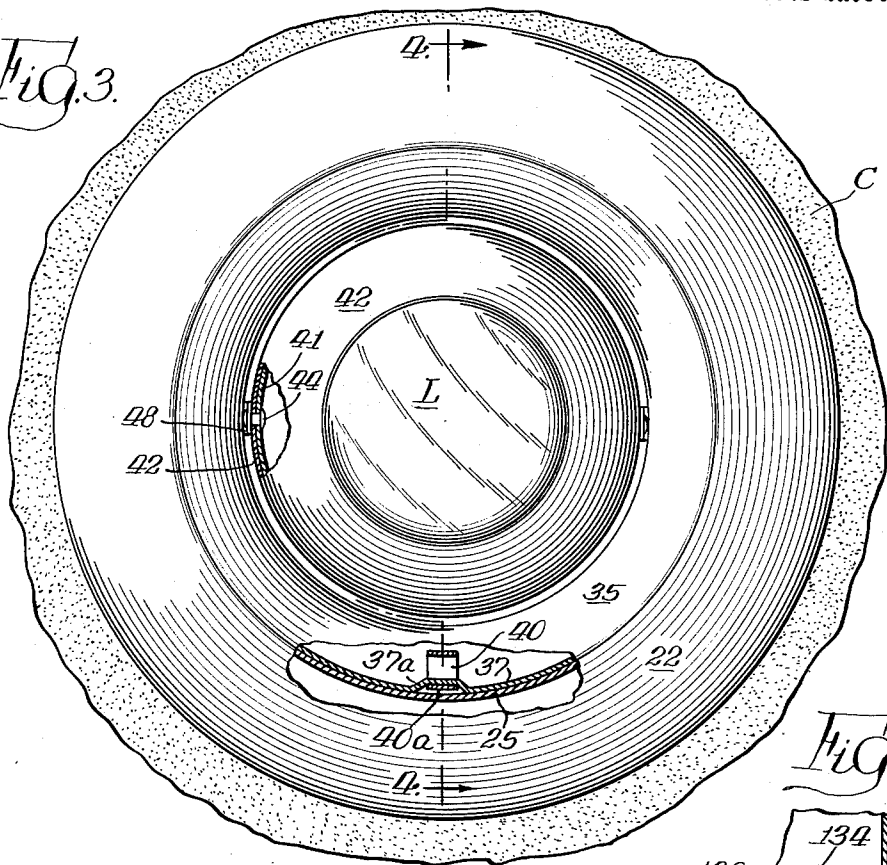

Fig. 5.

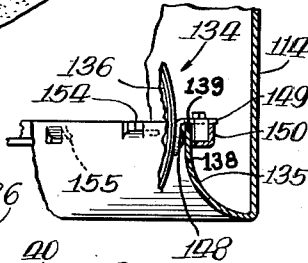
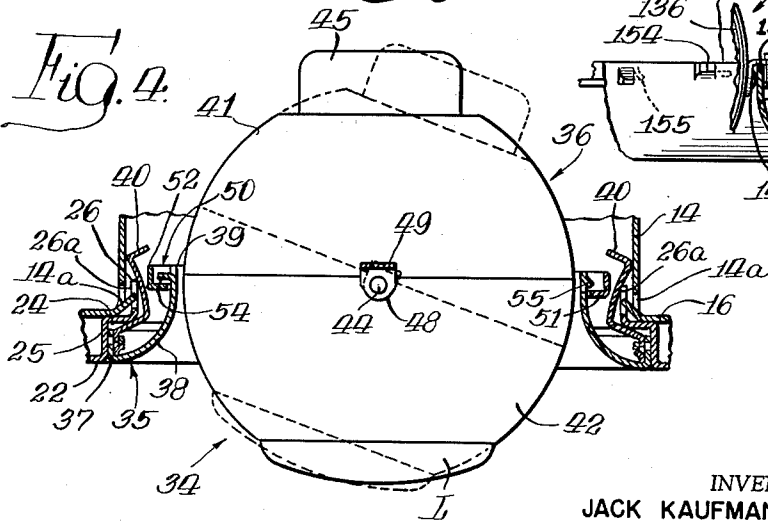

Fig. 4.



INVENTORS.  
JACK KAUFMAN

By Schroeder, Hoffgren, Brady & Wegner  
Attys.

1

2,984,739

**LIGHTING FIXTURE ASSEMBLY**

Jack Kaufman, Chicago, Ill., assignor to Markstone Manufacturing Company, a corporation of Illinois

Filed May 15, 1958, Ser. No. 735,567

10 Claims. (Cl. 240—78)

This invention relates to a lighting fixture, and in particular it relates to a fixture of the type in which there is a supporting shell for a spotlight mounted for rotary and rocking movement in an outer casing, so as to direct the spotlight beam to any point within a predetermined area. Such fixtures may be either recess or surface mounted.

The principal object of the present invention is to provide a lighting fixture of the type having a rotatable and rockable lamp shell which is of very simple and inexpensive construction, and in which the spotlight shell is very easily mounted in the housing.

Another object of the invention is to provide an assembly including a rotatable and rockable lamp shell which may be easily assembled either in a recessed or surface mounted housing.

Yet another object of the invention is to provide a recessed lighting fixture of the described type in which a cover frame is detachably secured to the lower portion of an outer recessed housing, and an assembly including the lamp shell is secured to the cover frame by a snap spring engagement.

Yet another object of the invention is to provide a recessed lighting fixture of the described type in which a mounting frame is detachably secured in a recess in the cover frame by means of spring clips, and a rotatable ring carried on the top margin of the mounting frame has brackets affording pivotal support for the lamp shell.

Yet another object of the invention is to provide a recessed lighting fixture of the described type in which the lamp shell is rotatable with respect to a mounting frame by means of a pair of angle members which are pivotally mounted on the lamp shell and have fingers slidably seated on the mounting frame, and in which inter-engaging means supported on the frame and the shell limit rocking of the fingers on the flange.

Still another object of the invention is to provide a recessed lighting fixture of the described type in which the lamp shell is constructed of two bowl-like members which have overlapping circumferential margins, and which are secured together by the pivots for the lamp shell.

Still a further object of the invention is to provide a recessed lighting fixture of the described type in which a lamp bulb may be changed without removing the shell from the housing, or dismantling the shell.

The invention is illustrated in the accompanying drawings in which:

Fig. 1 is a central vertical sectional view of a recessed fixture embodying the invention, taken substantially as illustrated along the line 1—1 of Fig. 2;

Fig. 2 is a transverse sectional view taken substantially as illustrated along the line 2—2 of Fig. 1;

Fig. 3 is a bottom plan view with parts broken away to show detailed construction;

Fig. 4 is a fragmentary sectional view taken substantially as illustrated along the line 4—4 of Fig. 3 with

2

the lamp shell illustrated in solid lines in an upright position and in broken lines in a tilted position; and

Fig. 5 is a fragmentary sectional view of the lamp shell assembly in a surface mounted housing.

Referring to the drawings in greater detail, and referring first to Figs. 1 and 2, a metal supporting plate 5 for a recessed fixture is provided with offset ears 6 which may be set in the plaster of a ceiling C. The supporting plate 5 has a center opening 7 surrounded by a plaster ring 8 which is perpendicular to the supporting plate 5 and which is adapted to extend downwardly through a hole in the ceiling C. Struck from the plaster ring 8, and lying in the plane of the supporting plate 5 are three radially extending tabs 9 which have threaded holes 10. The opening 7 in the supporting plate is illustrated in the drawings as circular, so that the plaster ring 8 is annular; but it is obvious that the same type of mounting arrangement could be used with recessed fixtures which are rectangular in cross section and thus would require a rectangular opening in the supporting plate and a rectangular "ring," or could be used with fixtures of other shapes.

A fixture housing mounting screw, indicated generally at 11, has a threaded shank 12 engaged in the threaded hole 10 is the tab 9, with an enlarged head 13 extending below the level of the ceiling C, there being a screw 11 in each of the three tabs 9.

A fixture housing, indicated generally at 14, has an upright cylindrical sidewall 15 at the lower margin of which is an outwardly extending annular mounting flange 16 having a keyhole slot 17 to engage each of the mounting screws 11. Each of the keyhole slots 17 has the usual generally round portion 18, and a narrower portion 19, so that the round portions 18 may be passed around the screw heads 13 and the narrow portions 19 engaged with the screw heads to hang the fixture housing 14 loosely in the plaster ring. Screws 11 may then be tightened as seen in Fig. 1 to draw the fixture housing flange 16 firmly against the plaster ring 8 or the ceiling C. The fixture housing 14 has a top wall 20 on which is secured a conventional junction box 21.

After the fixture housing 14 is securely fixed in place by means of the screws 11, a cover frame indicated generally at 22 (see Figs. 1, 3, and 4) is positioned so that it underlies the flange 16 of the fixture housing 14, and is detachably secured in place by means of a pair of spring hooks indicated generally at 23. As seen in Fig. 1, the cover frame 22 has an internal peripheral recess 24 which is defined at its outer margin by an upright annular shoulder 25, and at its inner margin by an upright inner rim 26 which extends upwardly into the housing. The spring hooks 23 have eyes 28 which engage holes 29 in the inner rim 26, coil portions 30 which extend upwardly along the side wall 15 of the housing 14, and hooks 31 which are adapted to engage slots 32 in the wall of the housing. Engagement of the hooks 31 with the slots 32 is readily accomplished by means of the single loops 33 which serve as finger pieces for the extension of the coils 30 in order to engage the hooks 31 with the slots 32. Thus, the cover frame 22 is held firmly against the ceiling C in a position where it conceals the screw heads 13, the flange 16 of the housing 14, and the edge of the plaster ring. In order to simplify the proper rotational positioning of the cover frame 22 to align spring hooks 23 with slots 32, the upright inner rim 26 of said frame is provided with a pair of notches 26a which may engage with inwardly struck ears 14a at the bottom portion of the wall 15 of the housing 14. Since the cover frame 22 is exposed to view, it is in the form of a decorative piece, and is suitably finished.

The above described spring hook structure for the cover frame is described and claimed in the copending

application of Marvin A. Horwitz and Jack Kaufman, Serial Number 735,568, filed May 15, 1958.

Detachably secured within the cover frame 22 is a shell assembly indicated generally at 34. As best seen in Figs. 1 and 4, the shell assembly 34 consists generally of a mounting frame indicated generally at 35 and a lamp-carrying shell indicated generally at 36.

As best seen in Fig. 4, the mounting frame 35 is an annular member which has an upright outer flange 37 bearing against the shoulder 25 of the cover frame, and a body portion 38 which is arcuate in cross section and terminates at its upper end in an upright inner flange 39 which extends into the housing 14. Secured to the outer flange 37 is a pair of inwardly and upwardly extending spring fingers 40 which are biased radially outwardly with respect to the flange 37 so that when the mounting frame 35 is thrust upwardly into the opening in the cover frame the spring fingers 40 engage the upper margin of the upright inner rim 26 of the cover frame 22 so as to firmly retain the lamp shell assembly 34 in the cover frame. As seen in Fig. 3, the spring fingers may conveniently be mounted in the outer flange 37 by engaging an upstanding tab 40a at the lower end of each finger with a loop 37a which is struck inwardly from flange 37.

The lamp shell 36 is formed from a pair of metal spinings including an upper shell portion 41 and a lower shell portion 42 which are generally bowl-shaped and have their circumferential margins overlapping in a band 43 so that the two shell portions may be secured together by a pair of oppositely-positioned rivets 44. Mounted in the top of lamp shell 36 is a porcelain wire-receiving base 45 for a screw shell 46 in which a spotlight L may be screwed. The lower portion of the spotlight L extends through a circular opening 47 in the bottom of the lamp shell 36 for a sufficient distance that it may be readily grasped in order to unscrew it from the screw shell 46 without dismantling the lamp shell 36.

The rivets 44 are sufficiently loose to swivelly receive a pair of narrow finger-like members which, in the particular embodiment, are angle brackets 48 which are seen in Fig. 1 to be mounted on the outside of the shell with radially-extending fingers 49 projecting outwardly over the upper margin of the inner flange 39 of the mounting frame 35. Secured to the fingers 49 outside the inner flange 39 is a ring 50 which is of right angle cross section so as to have a base 51 and an upright web 52. As seen in Figs. 1 and 2, fingers 49 overlie web 52 and have spaced depending ears 53 between said web and the inner flange 39 of the mounting frame, to provide a rigid, stable connection between the ring and the angle brackets 48. The ring encircles said flange 39 and is rotatable thereon by sliding movement of the fingers 49 along the upper edge of the flange. As best seen in Figs. 2 and 4, a single outwardly-bent stop lug 54 is formed at the upper margin of the upright inner flange 39 of the mounting frame 35 extending into the paths of the mounting bracket fingers 49 to which the ring 50 is secured, so as to limit rotary motion of the ring and the lamp shell 36 to approximately 180°. To retain the ring 50 and lamp shell 36 on the mounting frame 35 the inner flange 39 of the frame has three external shear-formed, resilient detents 55 over which the ring is snapped during assembly.

Manufacture and assembly of the shell assembly 34 is quite simple. The ceramic wire base 45 and screw shell 46 may be mounted in the upper portion 41 of the lamp shell 36 before the upper and lower portions are secured together. The opposed angle brackets 48 may be mounted on the outside of the shell 36 when the retaining rivets 44 are fastened in place. The ring 50 may then be secured to the fingers 49 by suitable screws, and the ring 50 then has one side positioned below the stop lug 54 and is snapped over the resilient detents 55.

The shell assembly 34, including the mounting frame

35 and the lamp shell 36 assembled therewith, may be very readily pressed into place in the cover frame 22 by inserting the mounting frame 35 in the peripheral recess 24 of the cover frame and thrusting it upwardly until the spring fingers 40 snap into engagement over the upper margins of the inner rim 26 of the cover frame. If it is ever necessary to remove the shell assembly 34 from the cover frame 22 it is necessary only to remove the lamp L from the shell, grasp the shell 36 by its lower margin and pull downwardly. With the shell assembly 34 removed, it is equally easy to remove the cover frame 22 by gripping the finger pieces 33 of the spring hooks 23 in order to unhook the hooks from the holes 32 in the side wall of the housing.

The invention has been described as applied to a recessed fixture. Fig. 5 illustrates a shell assembly, indicated generally at 134, applied to a surface mounted fixture housing, indicated generally at 114. In this structure the housing 114 may be secured to a junction box cover plate in any convenient way. At the lower margin of housing 114 is an integral mounting frame 135 the contour of which is identical with that of the spring-attached mounting frame 35 used in the recessed fixture, said frame 135 having a body portion 138 which terminates in an upright inner flange 139. A lamp shell 136 which is identical in structure with lamp shell 36 is provided with a pair of opposed angle brackets 148 which have fingers 149 overlying the inner flange 139 and secured to a ring 150. An outwardly extending stop lug 154 is in the path of the fingers 149 to limit rotation of the shell to about 180°, and the integral mounting frame 135 has shear formed detents 155 over which the ring 150 is snapped during assembly. This may be accomplished because the housing 114 is open at the upper end, and need not be mounted on a supporting plate until the shell assembly 134 is already in place.

The foregoing detailed description is given for clearness of understanding only and no unnecessary limitations should be understood therefrom, as modifications will be obvious to those skilled in the art.

I claim:

1. In a recessed lighting fixture, in combination: a fixture housing; means for mounting said housing in a ceiling; a cover frame detachably secured in underlying relationship to the outer margin of said housing, said frame having an internal peripheral recess with an upright inner rim extending into the housing; and a shell assembly detachably secured within said cover frame, said shell assembly including a mounting frame which has an upright, circular, inner flange, said mounting frame being seated in said recess with the inner flange within said inner rim, resilient fingers on said mounting frame in frictional snap engagement with the rim of the cover frame and having outwardly extending portions overhanging the top edge of said rim, and a lamp carrying shell mounted in said circular flange for rotary and rocking movement, the upper portion of said shell being in the housing and the lower portion extending below the cover frame.

2. In a recessed lighting fixture, in combination: a fixture housing; means for mounting said housing in a ceiling; a cover frame detachably secured in underlying relationship to the outer margin of said housing, said frame having an internal peripheral recess with an upright inner rim extending into the housing; and a shell assembly detachably secured within said cover frame, said shell assembly including a mounting frame which has an upright outer flange and an upright, circular, inner flange, said mounting frame being seated in said recess with the outer flange in the outer part of said recess and the inner flange within and in spaced relationship to said inner rim, resilient fingers on said outer flange of the mounting frame in frictional snap engagement with the rim of the cover frame and having outwardly extending portions overhanging the top edge of

5

said rim, and a lamp carrying shell mounted in said circular flange for rotary and rocking movement, the upper portion of said shell being in the housing and the lower portion extending below the cover frame.

3. In a recessed lighting fixture, in combination: a fixture housing; means for mounting said housing in a ceiling; a cover frame detachably secured in underlying relationship to the outer margin of said housing, said frame having an internal peripheral recess with an upright inner rim extending into the housing; a mounting frame which has an upright, circular, inner flange, said mounting frame being seated in said recess with the inner flange within and in spaced relationship to said inner rim; resilient fingers on said mounting frame in frictional snap engagement with the rim of the cover frame and having outwardly extending portions overhanging the top edge of said rim; a lamp carrying shell within said inner flange, the upper portion of said shell being in the housing and the lower portion extending below the cover frame; a pair of opposed angle members pivotally secured to the shell with arms overhanging and resting on the upper margin of said inner flange so as to be rotatable thereon; a ring secured to said arms loosely surrounding the flange so as to be rotatable about said flange; and stop means to limit rotation of the angle members and ring.

4. In a lighting fixture, in combination: a fixture housing; means for securing said fixture housing to a ceiling; means at the lower end of said housing providing a recess with an upright inner rim extending into the housing; and a shell assembly detachably secured within said inner rim, said shell assembly including a peripheral mounting frame which has an upright, circular, inner flange, said mounting frame being seated in said recess with the inner flange within said inner rim, resilient fingers on said mounting frame in frictional snap engagement with said inner rim and having outwardly extending portions overhanging the top edge of said rim, and a lamp carrying shell mounted in said circular flange for rotary and rocking movement, the upper portion of said shell being in the housing and the lower portion extending below the cover frame.

5. In a lighting fixture, in combination: a fixture housing; means for securing said fixture housing to a ceiling; a mounting frame secured to and extending inwardly from the lower margin of said housing, said mounting frame having an upright, circular inner flange which ex-

6

tends upwardly into the housing; a lamp carrying shell within said inner flange, the upper portion of said shell being in the housing and the lower portion extending below the cover frame; opposed, narrow, finger-like means pivotally secured to the shell with portions overhanging and resting on the upper margin of said inner flange so as to be rotatable thereon; a ring secured to said opposed means loosely surrounding the flange so as to be rotatable about said flange; and stop means to limit rotation of the finger-like means and ring on the flange.

6. The device of claim 5 in which the ring is of right angle cross section with a base parallel to the margin of the inner flange and an upright web spaced outwardly from said flange, and depending circumferentially spaced ears on each pivoted means abut said base to stably secure the ring to the pivoted means.

7. The device of claim 6 in which the opposed means are angle members, and each angle member includes a portion extending over the upright web of the ring.

8. The device of claim 5 in which the mounting frame has a plurality of circumferentially spaced, outwardly extending resilient detents which project over the inner marginal portion of the ring and retain it loosely on the mounting frame.

9. The device of claim 5 in which the lamp carrying shell consists of upper and lower shell portions which overlap along their circumferential margins, and in which the pivotal mounting for each of the finger-like means comprises a rivet extending through said overlapping circumferential margins, the finger-like means being pivoted on the rivet.

10. The device of claim 5 which includes a cover frame detachably secured in underlying relationship to the outer margin of the housing, said frame having an internal peripheral recess with an upright inner rim extending into the housing, and the mounting frame is seated in said internal recess of the cover frame and has its inner flange extending upwardly within, and in spaced relationship to said inner rim.

#### References Cited in the file of this patent

##### UNITED STATES PATENTS

2,554,258	Lundquist -----	May 22, 1951
2,572,825	Guth -----	Oct. 23, 1951
2,587,423	Young -----	Feb. 26, 1952
2,649,535	Feder -----	Aug. 18, 1953
2,835,791	Horowitz -----	May 20, 1958