



(86) Date de dépôt PCT/PCT Filing Date: 2001/02/13
 (87) Date publication PCT/PCT Publication Date: 2001/08/23
 (85) Entrée phase nationale/National Entry: 2002/07/24
 (86) N° demande PCT/PCT Application No.: US 2001/004675
 (87) N° publication PCT/PCT Publication No.: 2001/060952
 (30) Priorités/Priorities: 2000/02/15 (60/182,679) US;
 2001/01/05 (09/755,571) US

(51) Cl.Int.⁷/Int.Cl.⁷ C10G 67/04
 (71) Demandeur/Applicant:
 EXXONMOBIL RESEARCH AND ENGINEERING
 COMPANY, US
 (72) Inventeurs/Inventors:
 BEARDEN, ROBY JR., US;
 HOU, ZHIGUO, US;
 GORBATY, MARTIN LEO, US;
 FERRUGHELLI, DAVID THOMAS, US;
 OLMSTEAD, WILLIAM NEERGAARD, US;
 MEYERS, RONALD DAMIAN, CA
 (74) Agent: BORDEN LADNER GERVAIS LLP

(54) Titre : VALORISATION DES CHARGES D'ALIMENTATION LOURDES REPOSANT SUR LEUR DESASPHALTAGE AU SOLVANT SUIVI PAR L'HYDROTRAITEMENT AU COULIS DE L'ASPHALTE OBTENU DU DESASPHALTAGE AU SOLVANT

(54) Title: HEAVY FEED UPGRADING BASED ON SOLVENT DEASPHALTING FOLLOWED BY SLURRY HYDROPROCESSING OF ASPHALT FROM SOLVENT DEASPHALTING

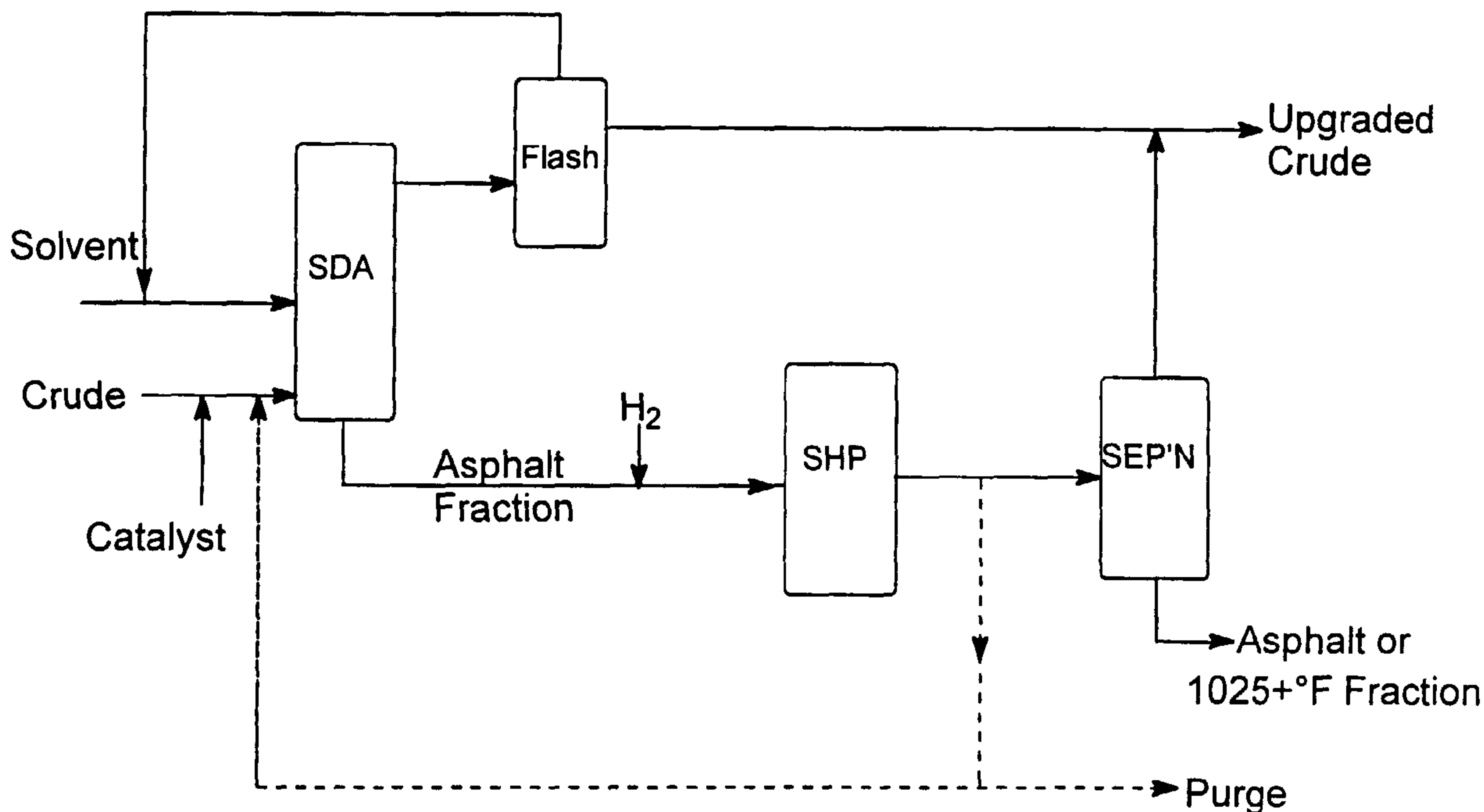

(57) Abrégé/Abstract:

A process for upgrading a feedstream, said process comprising: (a) solvent deasphalting, under solvent deasphalting conditions, said feedstream to obtain a first product stream comprising deasphalted oil and a second product stream comprising asphalt product; (b) slurry hydroprocessing said asphalt product in a slurry hydroprocessing unit under slurry hydroprocessing conditions to obtain a hydroprocessed product; and (c) separating an upgraded oil from the hydroprocessed product and unconverted asphaltene bottoms.

(12) INTERNATIONAL APPLICATION PUBLISHED UNDER THE PATENT COOPERATION TREATY (PCT)

(19) World Intellectual Property Organization
International Bureau(43) International Publication Date
23 August 2001 (23.08.2001)

PCT

(10) International Publication Number
WO 01/60952 A1(51) International Patent Classification⁷: C10G 67/04

(21) International Application Number: PCT/US01/04675

(22) International Filing Date: 13 February 2001 (13.02.2001)

(25) Filing Language: English

(26) Publication Language: English

(30) Priority Data:

| | | |
|------------|-------------------------------|----|
| 60/182,679 | 15 February 2000 (15.02.2000) | US |
| 09/755,571 | 5 January 2001 (05.01.2001) | US |

(71) Applicant: EXXONMOBIL RESEARCH AND ENGINEERING COMPANY [US/US]; 1545 Route 22 East, P.O. Box 900, Annandale, NJ 08801-0900 (US).

(72) Inventors: BEARDEN, Roby, Jr.; 505 Stanford Avenue, Baton Rouge, LA 70808 (US). HOU, Zhiguo; 2028 Oakdale Drive, Baton Rouge, LA 70810 (US). GORBATY, Martin, Leo; 204 Twin Oaks Terrace, Westfield, NJ 07090 (US). FERRUGHELLI, David, Thomas; 10

Hardy Drive, Flemington, NJ 08822 (US). OLMSTEAD, William, Neergaard; 98 Lee's Hill Road, Basking Ridge, NJ 07920 (US). MEYERS, Ronald, Damian; Box 35, Site 2, R.R.8, Calgary, Alberta T2J 2T9 (CA).

(74) Agents: BAKUN, Estelle, C. et al.; ExxonMobil Research and Engineering Company, 1545 Route 22 East, P.O. Box 900, Annandale, NJ 08801-0900 (US).

(81) Designated States (*national*): AL, AU, BA, BB, BG, BR, CA, CN, CU, CZ, EE, GE, HR, HU, ID, IL, IN, IS, JP, KR, LC, LK, LR, LT, LV, MG, MK, MN, MX, NO, NZ, PL, RO, RU, SG, SI, SK, SL, TR, TT, UA, UZ, VN, YU, ZA.(84) Designated States (*regional*): ARIPO patent (GH, GM, KE, LS, MW, MZ, SD, SL, SZ, TZ, UG, ZW), Eurasian patent (AM, AZ, BY, KG, KZ, MD, RU, TJ, TM), European patent (AT, BE, CH, CY, DE, DK, ES, FI, FR, GB, GR, IE, IT, LU, MC, NL, PT, SE, TR), OAPI patent (BF, BJ, CF, CG, CI, CM, GA, GN, GW, ML, MR, NE, SN, TD, TG).

Published:

— with international search report

[Continued on next page]

(54) Title: HEAVY FEED UPGRADING BASED ON SOLVENT DEASPHALTING FOLLOWED BY SLURRY HYDROPROCESSING OF ASPHALT FROM SOLVENT DEASPHALTING

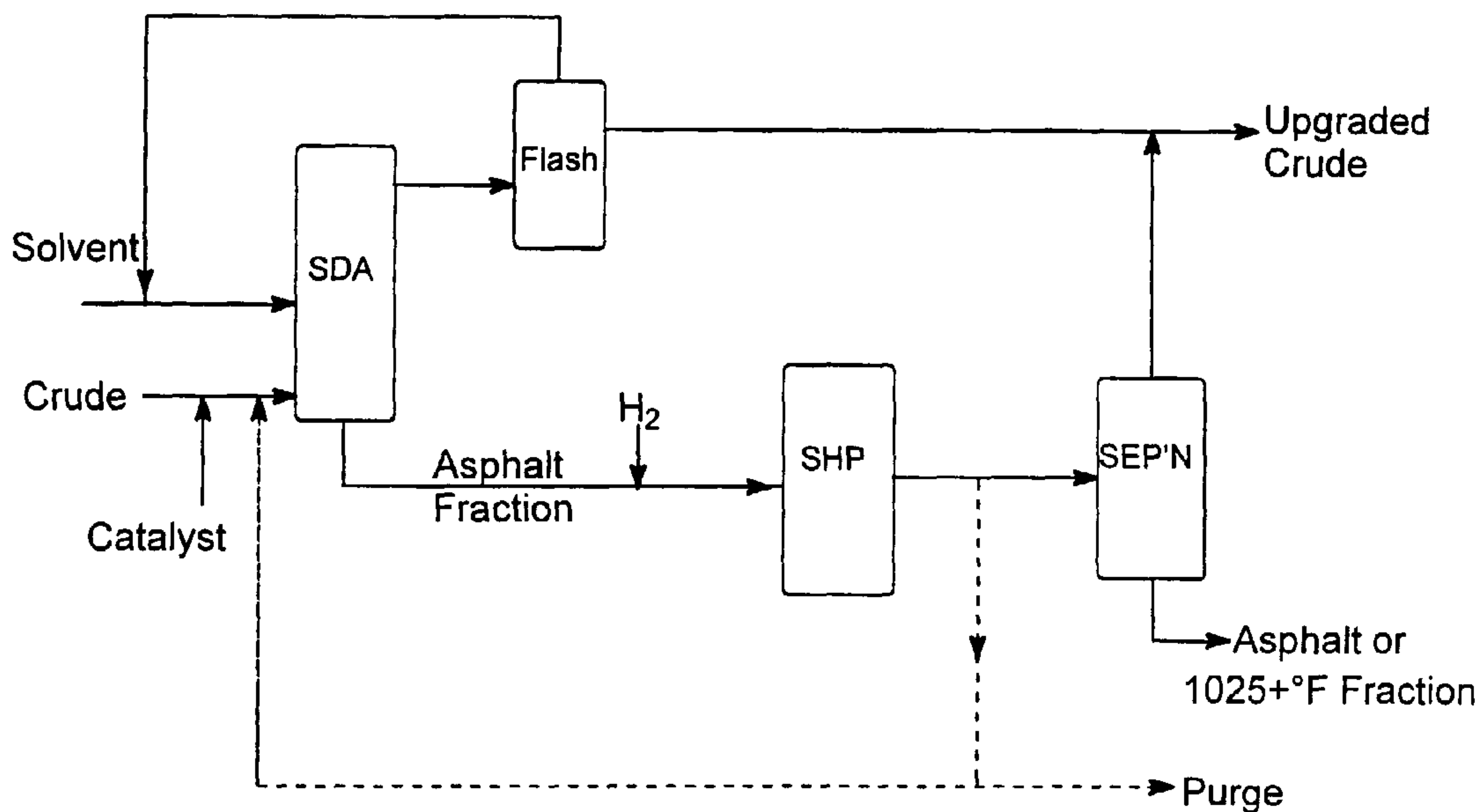

(57) Abstract: A process for upgrading a feedstream, said process comprising: (a) solvent deasphalting, under solvent deasphalting conditions, said feedstream to obtain a first product stream comprising deasphalted oil and a second product stream comprising asphalt product; (b) slurry hydroprocessing said asphalt product in a slurry hydroprocessing unit under slurry hydroprocessing conditions to obtain a hydroprocessed product; and (c) separating an upgraded oil from the hydroprocessed product and unconverted asphaltene bottoms.



WO 01/60952 A1

- 1 -

**HEAVY FEED UPGRADING BASED ON SOLVENT
DEASPHALTING FOLLOWED BY SLURRY HYDROPROCESSING
OF ASPHALT FROM SOLVENT DEASPHALTING**

FIELD OF THE INVENTION

The instant invention describes a process for upgrading heavy feeds utilizing a process wherein solvent deasphalting precedes a hydroprocessing step.

BACKGROUND OF THE INVENTION

The prior art describes many commercial state of the art processes for resid conversion. Hydrocracking, hydroconversion, delayed fluid coking and FLEXICOKING are some examples. Much prior art exists on stand alone slurry hydroprocessing and deasphalting processes.

For example, U.S. 3,896,025 teaches hydrocracking of a crude petroleum lubricating oil to improve its viscosity index. The feed may be obtained from a deasphalted vacuum residuum. U.S. 3,929,616 teaches solvent refining a heavy resid followed by hydrocracking the resulting raffinate and deasphalting of a fraction of the hydrocracked product. U.S. 4,030,429 and U.S. 5,601,697 teach solvent deasphalting followed by cracking. U.S. 5,024,750 and U.S. 4,940,529 teach catalytic cracking of solvent deasphalted oils obtained from hydrotreated heavy oils. U.S. 4,405,441 teaches hydrotreating followed by cracking and deasphalting. U.S. 4,400,264 teaches cracking followed by hydrotreating and deasphalting. U.S. 4,500,416 teaches deasphalting of an asphaltene-containing feed followed by hydrotreatment and thermal cracking of the asphalt fraction. The hydrotreatment process preferably includes a pre-

- 2 -

treatment step to remove metals which poison the catalyst. The deasphalting step is conducted on an asphaltenes-containing hydrocarbon mixture. The hydrotreated portion is then used to produce one or more distillate fractions or heavy fractions.

What is needed in the art are methods for economically treating the abundance of heavy crudes and increasing capacity for treating such crudes.

SUMMARY OF THE INVENTION

An embodiment of the instant invention is directed to a process for upgrading a non-hydrotreated feedstream, said process comprising:

(a) solvent deasphalting, under solvent deasphalting conditions, said feedstream to obtain a first product stream comprising deasphalted oil and a second product stream comprising an asphalt product; (b) slurry hydroprocessing said asphalt product in a slurry hydroprocessing unit under slurry hydroprocessing conditions to obtain a hydroprocessed product; and (c) separating an upgraded oil from the hydroprocessed product and unconverted asphaltene bottoms.

In another embodiment of the instant invention, upgraded oil recovered from the hydroprocessed product in step (c) is combined with the deasphalted oil of step (a) to obtain a finished upgraded crude.

The separation step (c) can be achieved by any means known to the skilled artisan. For example, the hydroprocessed product can undergo a second solvent deasphalting step in the same (as in step (a)) or a stand alone deasphalter or a distillation step to provide a liquid product with boiling point

- 3 -

below about 1025°F and residue boiling above about 1025°F. The 1025-°F liquid or deasphalted oil obtained from the second solvent deasphalting step may then be combined with the deasphalted oil of step (a) to obtain a finished upgraded crude. The 1025+°F may be combined with the asphalt fraction from the first SDA step or used directly as boiler fuel or as feed to a coker or a partial oxidation (POX) unit.

The asphalt product of step (a) is oftentimes referred to in the art as “rock”.

BRIEF DESCRIPTION OF THE FIGURE

The Figure depicts one possible embodiment of the instant invention. Catalyst or catalyst precursor is mixed with the feedstream to be processed. The feedstream and catalyst/precursor then enter the solvent deasphalting unit and are treated under solvent deasphalting conditions to produce a catalyst-containing asphalt stream and a deasphalted oil. The deasphalted oil may then go through a flash step to recover solvent which is recycled back to the deasphalting unit. The catalyst-containing asphalt stream is passed to a slurry hydroprocessing (SHP) unit where it is treated under SHP conditions and then subsequently to a separation zone (e.g., solvent deasphalting or vacuum distillation) to recover hydroconverted product and unconverted asphaltic residue. The hydroconverted product may then be combined with the deasphalted oil to obtain an asphalt-free, upgraded crude.

DETAILED DESCRIPTION OF THE INVENTION

As described herein a feed is processed utilizing a once-through process to cleave valuable, refinable hydrocarbon groups (saturates, naphthenoaromatics,

- 4 -

alkylaromatics, etc.) from large polynuclear aromatic molecules that comprise the asphaltic components of heavy feeds. The process includes solvent deasphalting followed by slurry hydrotreating. Surprisingly, catalyst concentration on feed needed to suppress the formation of coke precursors during the hydroprocessing step is less when using the asphaltic fraction of a given crude than when using the whole crude.

In a preferred mode of operation, catalyst or catalyst precursor is mixed with whole crude or with a residual fraction thereof. The mixture then enters a solvent deasphalter where the feed is separated into a deasphalted oil and a catalyst-containing asphalt stream. The asphalt stream is then fed to a slurry hydroprocessing reactor.

The feeds which may be treated in accordance with the teachings herein are heavy feeds (virgin crudes) and petroleum distillation residues having an API gravity of ≤ 10 to 15° with a viscosity of ≥ 60 centistokes at 60°C .

Importantly, the feeds which enter the solvent deasphalter of step (a) are virgin feeds or crudes which have not yet been hydroprocessed. Hence, the feeds are unhydroprocessed or non-hydroprocessed feeds. This allows for the initial solvent deasphalting (SDA) to recover as much valuable, virgin solvent deasphalted oil as possible and the subsequent hydroprocessing step to operate only on the most refractory (asphalt) fraction to remove aliphatic/naphthenic groups from the aromatic cores. Hence, it is preferred that the feed to the hydroprocessing step (b) consist essentially of, or consist of, the asphalt product from a solvent deasphalted feed. Thus, the instant scheme affords significant economies of scale.

- 5 -

The solvent deasphalter is operated using a C₃, C₄, C₅ paraffin or natural gas condensate, or combinations thereof, at about 275 to about 310°F at appropriate pressures and times to allow a separation to take place and equilibrium to be achieved thereby allowing for recovery of a deasphalted oil product (DAO) and an asphalt product. Pressures and times are easily determined by the skilled artisan.

The slurry hydroprocessing (SHP) process, or hydroprocessing step, can be run using a typical SHP catalyst or precursor such as vanadyl oxylate or phosphomolybdic acid. As used herein, catalyst precursor means a catalytically active material which need only undergo activation/sulfiding to function catalytically. Catalysts can be made in several ways including in-situ decomposition of a soluble or dispersible inorganic or organic molybdenum compound in oil. See, for example, U.S. 4,134,825; U.S. 4,548,700; U.S. 4,740,489; and U.S. 5,039,392. Other finely dispersed materials, including multimetallic compounds may also be used provided the quantity of metal is sufficient to keep the toluene insolubles level below 0.5%. Alternatively, the asphalt product from solvent deasphalting, which contains metals native to the feed being treated, can be calcined in a controlled manner to provide a metals-rich ash that can be utilized as catalyst for the hydroprocessing step.

If it is desirable to utilize catalyst derived from the asphalt product from solvent deasphalting, it is fed to a calciner and calcined at temperatures of less than about 1200°F to avoid sintering. Preferably, the burn is conducted below 1100°F and, more preferably, below 1000°F. A minimum temperature of about 570°F will be used for calcination. Controlled calcination produces a finely divided metals-rich ash which is utilized as catalyst for a SHP process. Alternatively, the asphalt can be passed to a coker prior to the controlled calcination step to obtain liquid products boiling below about 950°F, gaseous

- 6 -

products, and a coke product which is then fed to the calciner to obtain the metals-rich ash.

General process conditions for SHP include temperatures of about 650° to about 850°F and pressures from about 800 to about 2500 psig for reactor holding times sufficient to attain about 1025+°F to 1025-°F conversion of at least about 30%, preferably about 40%, and most preferably from about 50% to 60% or above.

Catalyst concentration on feed required for slurry hydroprocessing depends on the metal (or combination of metals) chosen, as well as on particle size of the catalyst composite. Above all, a sufficient amount of catalyst must be used to suppress the formation of incompatible carbonaceous material (toluene insoluble coke), such that the yield of this material is no more than 0.5 wt% based on feed, preferably less than 0.4 wt% and most preferably below 0.1 wt% so as to avoid reactor fouling.

Operation with micron-sized catalysts that are formed in-situ in the feed from oil soluble or oil dispersible compounds, as disclosed in U.S. 4,134,825 will require metal concentrations on feed that fall in the range of about 10 to 800 wppm. With the molybdenum containing catalyst, a preferred catalyst, the molybdenum concentration on feed will range from 10 to 800 wppm, preferably 10 to 500 wppm, and more typically from 50 to 200 wppm, and most preferably 10 to 50 wppm. Of particular significance for the present invention, it was found that less Mo is required for slurry hydroprocessing of asphalt than for the parent feed when operating at comparable conversion and comparable toluene insoluble coke yield. One skilled in the art can readily determine the amount of catalyst necessary to conduct the process.

- 7 -

In general, as particle size of the catalyst composite increases, more catalyst must be used.

Conditions for solvent deasphalting of the SHP product oil will depend on the quality of product desired and are well known to those skilled in the art. However, in a preferred process mode, conditions are chosen such that the yield of upgraded, essentially asphaltene-free product (upgraded oil of step (c)) that is recovered from the asphalt feed will range from about 50 to 70 wt%. Generally, the highest yield is obtained when solvent deasphalting is used to recover upgraded liquid as compared to recovery via distillation. As used herein, essentially asphaltene-free means that the product contains only trace amounts of asphaltene remaining following the SHP process.

Liquid conversion product from the SHP reactor can be recovered by vacuum flash distillation or by solvent deasphalting (SDA). If SDA is chosen, the SHP product may be sent to the solvent deasphalter that is used for the process feed. In such an integrated operation, a portion of the asphalt from solvent deasphalting that is sent to the SHP unit will be purged to control buildup of catalyst solids and nonconvertible asphalt fractions. In such a process, a means of catalyst recycle is also provided. Alternatively, a small dedicated deasphalter could be used to recover SHP product. The recovered SHP product, i.e., the essentially asphaltene-free liquid product, may be combined with the DAO from the initial SDA step to provide a finished upgraded crude. Unconverted asphalt (recovered by distillation as an asphalt rich bottoms, or as the asphalt purge stream from solvent deasphalting) may be used as fuel, or feed to a coker or partial oxidation unit.

Preferably, a second solvent deasphalting step will be used.

- 8 -

Hence, if desired, an integrated process could be run whereby the initial solvent deasphalting (a) is conducted, the asphalt is then passed to the hydrotreater (b), and the liquid conversion product from the hydrotreater is recycled to the solvent deasphalter (c).

Furthermore, if ash catalyst is utilized, the asphalt from step (a) or step (c) can be used to provide catalyst for the hydrotreater affording a fully integrated process. In such a scheme, purge of built up catalyst would be required and a sufficient amount of ash catalyst to fuel the hydroprocessing step would be produced.

The yield and quality of the upgraded crudes produced herein is dependent upon the conditions selected for the feed deasphalting unit (DAU). For example, the yield of upgraded crude (virgin DAO plus 1025-°F liquid from hydroprocessing) increases from 83% to 89% when butane is substituted for propane in the feed deasphalting step (Table 2). With pentane, deasphalting yields should exceed 90 vol%.

The following examples are for illustrative purposes and are not meant to be limiting.

The asphalt samples used for the hydroprocessing experiments described in Table 2 came from a deasphalting pilot run where the solvent:feed ratio was typically about 8 liters/kg.

TABLE 1
FEEDSTOCK INSPECTIONS

| | Cold Lake Crude | Propane Deasphalting | Butane Deasphalting |
|--------------------|-----------------|-------------------------|------------------------|
| Asphalt Yield, wt% | | 49.1 | 32.2 |
| DAO yield, wt% | | 50.9 | 67.8 |
| DAO yield, Vol% | | | 71.0 |
| DAO Properties | | | |
| Specific gravity | 0.9995 | 0.9346 | 0.9541 |
| API | 10.1 | | 16.8 |
| Sulfur, wt% | 4.8 | 3.5 | 3.8 |
| Nickel, wppm | 79 | 1.9 | 8.0 |
| Vanadium, wppm | 204 | 3.0 | 16.0 |
| CCR, wt% | 13 | 0.8 | 3.3 |

EXAMPLES (A-E) Asphalt hydroprocessing followed by vacuum distillation

The following procedure was used to carryout asphalt hydroprocessing. To a 300 CC autoclave, equipped for stirring and gas flow-through, there were charged 130g. of asphalt and 1.3 to 13.3g. of preformed catalyst concentrate , which furnished the catalyst concentrations on feed that are noted in Table 2. Upon flushing with nitrogen, the autoclave was charged with hydrogen so that the hydrogen pressure at the target reaction temperature of 788°F was either 700 psig or 1200 psig. The autoclave contents were stirred at about 1600 rpm and held at 788°F for about 85 minutes.

- 10 -

The quality of the upgraded crudes (Table 2) is attractive relative to the starting crudes (Table 1), particularly with regard to reduced metals and Conradson Carbon (CCR) content.

Reference to Test No. E illustrates the yield and quality credits inherent in the present invention relative to what can be obtained by deasphalting alone (Table 1, C₄ deasphalting column). Note that overall liquid yield has increased from 70.0 wt% on bitumen (for deasphalting alone) to 85% for the combination process. Moreover, liquid quality (metals, Conradson Carbon) is superior for the combination process product.

- 11 -

TABLE 2
SDA/SHP EXAMPLES

| Test No. | A | B | C | D | E |
|-------------------------------|--------------------|--------------------|--------------------|--------------------|--------------------|
| Rock From: | C ₃ SDA | C ₃ SDA | C ₃ SDA | C ₃ SDA | C ₄ SDA |
| | | | | | |
| Mo, wppm | 500 | 250 | 125 | 54 | 50 |
| Pressure, psig | 700 | 700 | 700 | 1200 | 1200 |
| Temperature, °F | 788 | 788 | 788 | 788 | 788 |
| Minutes @ 788°F | 85 | 85 | 85 | 85 | 85 |
| Toluene Insolubles, wt% | <0.1wt% | <0.1wt% | <0.1wt% | <0.1wt% | <0.1wt% |
| | | | | | |
| Yield Slurry 1025-°F Liquids | | | | | |
| Based on Rock, wt% | 55 | 57 | 57 | 56 | 46 |
| Based on Bitumen, wt% | 27.0 | 28.0 | 28.0 | 27.5 | 22.6 |
| | | | | | |
| Total Liquids (DAO + 1025-°F) | | | | | |
| wt% of Bitumen | 76.7 | 78.1 | 78.8 | 78.3 | 82.6 |
| vol% of Bitumen | 82.9 | 83.9 | 84.9 | 84 | 85 |
| | | | | | |
| Total Liquid Inspections | | | | | |
| API | 21.3 | 20.6 | 20.6 | 20.4 | 18.7 |
| Vis., cSt @ 25°C* | 51 | 54 | 51 | 56 | 141 |
| Ni + V, wppm** | **3.2 | **3.1 | 3.4 | 3.4 | **19.6 |
| Sulfur, wt% | 3.14 | 3.21 | 3.27 | 3.32 | 3.66 |
| Conradson Carbon, wt%*** | ***0.9 | ***0.9 | 0.7 | ***0.9 | ***2.3 |

* Target viscosity is 50 cSt at 40°C.

** Calculated value. Assumes no metals in distilled (1025-°F) slurry liquids.

*** Calculated value. Assumes 1.0 wt% CCR in distilled (1025-°F) slurry liquids.

- 12 -

Toluene insolubles (coke) reported in the table above were measured on the residue (1025°F+) which remained after first distilling the material produced by carrying out slurry hydroprocessing on C3 or C4 asphalt as shown in the table. These data show that coke was suppressed substantially by carrying out slurry hydroprocessing on asphalt even at the low catalyst concentration of 50 wppm. In contrast, a sample of asphalt treated under the same hydroprocessing conditions in the absence of catalyst contained 1.9 wt % toluene insoluble material.

Example F

In this example, the product resulting from the hydroprocessing of C₃ asphaltenes under the conditions described in Table 2 using 50 ppm of catalyst was deasphalted with a 7:1 volume of C₅ (pentane) solvent. The precipitated asphaltenes were removed by filtration and the C₅ solvent was removed by evaporation. This DAO sample was blended in the appropriate ratio with the light fraction collected during the hydroprocessing experiment and also the appropriate ratio of the C₃ DAO. The overall liquid yield of the process is 85.8 weight percent. The density of the blended product is 0.9343 at 15°C, sulfur is 3.26 wt% and the viscosity is 71 cP at 25°C.

The data show that the yield when deasphalting follows hydrotreating is significantly higher than that obtained when distillation is utilized post hydrotreating.

Example G (Comparative)

It is of interest to compare results in table 2 to an experiment where the slurry hydroprocessing was carried out on whole bitumen as opposed to the C₃ or C₄ asphalt as described in Table 2. When slurry hydroprocessing is carried

- 13 -

out on whole bitumen under similar conditions of temperature, pressure and residence time, with low catalyst concentration (i.e. 50 to 100 wppm), there is an increased formation of toluene insoluble material. The toluene insoluble material measured under these conditions is typically on the order of 0.5wt% relative to feed. This demonstrates that there is an advantage in terms of coke suppression when slurry hydroprocessing is carried out on the asphalt fraction derived from solvent deasphalting compared to slurry hydroprocessing on the whole bitumen fraction.

- 14 -

CLAIMS:

1. A process for upgrading a feedstream, said process comprising:
 - (a) solvent deasphalting, under solvent deasphalting conditions, said feedstream to obtain a first product stream comprising deasphalted oil and a second product stream comprising asphalt product; (b) slurry hydroprocessing said asphalt product in a slurry hydroprocessing unit under slurry hydroprocessing conditions to obtain a hydroprocessed product; and (c) separating an upgraded oil from the hydroprocessed product and unconverted asphaltene bottoms.
2. The process of claim 1 further comprising combining said recovered upgraded oil of said step (c) with said deasphalted oil of step (a) to obtain a finished upgraded crude.
3. The process of claim 1 wherein said hydroprocessed products are further solvent deasphalted to obtain solvent deasphalted oil.
4. The process of claim 3 wherein said solvent deasphalted oil obtained from said hydroprocessed product is combined with said deasphalted oil of said step (a).
5. The process of claim 1 wherein said hydroprocessed product is distilled to recover 1025-°F liquid and said 1025-°F liquid is then combined with said solvent deasphalted oil of step (a).
6. The process of claim 1 wherein said feed stream is selected from the group consisting of virgin crudes or petroleum distillation residues having an

- 15 -

API gravity of ≤ 10 to 15° with a viscosity of ≥ 60 centistokes at 60°C , and mixtures thereof.

7. The process of claim 1 wherein said solvent deasphalting is conducted utilizing as a solvent a C_3 , C_4 , C_5 paraffin, natural gas condensate, or combinations thereof.

8. The process of claim 1 wherein said solvent deasphalting is conducted at about 275 to about 310°F .

9. The process of claim 1 wherein said slurry hydroprocessing is conducted at temperatures of about 725°F to about 850°F and pressures from about 800 to about 2500 psig.

10. The process of claim 1 wherein said slurry hydroprocessing step (b) is conducted utilizing a catalyst, catalyst precursor, or combination of a catalyst and catalyst precursor selected from the group consisting of vanadyl oxylate, phosphomolybdic acid, calcined asphalt from solvent deasphalting, and mixtures thereof.

11. The process of claim 10 wherein said catalyst, catalyst precursor or combination thereof is sulfided in-situ or ex-situ.

12. The process of claim 1 wherein said hydroprocessing step utilizes the residue from calcining of asphalt from solvent deasphalting as catalyst.

13. The process of claim 3 wherein said solvent deasphalting is accomplished by recycling said hydroprocessed products to said step (a).

- 16 -

14. A fully integrated process for upgrading a feedstream comprising the steps of (a) solvent deasphalting, under solvent deasphalting conditions, said feedstream to obtain a first product stream comprising deasphalted oil and a second product stream comprising asphalt product; (b) slurry hydroprocessing said asphalt product in a slurry hydroprocessing unit under slurry hydroprocessing conditions to obtain a hydroprocessed product; and (c) recycling said hydroprocessed product of said step (b) to said step (a).

15. The process of claim 10 wherein the concentration of molybdenum catalyst on feed is 10 to 800 wppm, calculated as the metal.

16. The process of claim 1 wherein the amount of toluene insolubles produced by said process is no more than 0.5 wt% based on said asphalt product hydroprocessed.

