

(51) International Patent Classification ⁶ :

A61B 17/36, 17/39

A1

(11) International Publication Number:

WO 96/04858

(43) International Publication Date:

22 February 1996 (22.02.96)

(21) International Application Number: PCT/IB95/00546

(22) International Filing Date: 10 July 1995 (10.07.95)

(30) Priority Data:

08/289,958

12 August 1994 (12.08.94)

US

(71) Applicant: VALLEYLAB, INC. [US/US]; 5920 Longbow Drive, Boulder, CO 80301 (US).

(72) Inventor: TAYLOR, Kenneth, D.; 375 Golden Eagle Drive, Broomfield, CO 80020 (US).

(74) Agents: SPIEGEL, Allen, J. et al.; Pfizer Inc., 235 East 42nd Street, New York, NY 10017 (US).

(81) Designated States: AU, CA, DE, JP, MX, European patent (AT, BE, CH, DE, DK, ES, FR, GB, GR, IE, IT, LU, MC, NL, PT, SE).

Published*With international search report.**Before the expiration of the time limit for amending the claims and to be republished in the event of the receipt of amendments.*

(54) Title: LASER-ASSISTED ELECTROSURGERY SYSTEM

(57) Abstract

A laser and electrosurgical system (10) has a handpiece (12) with a proximal and distal end (13) and (14) from which laser radiation (17) and/or electrosurgical energy (18) is selectively or concurrently directed. The ends are along an axis; an electrode extends distally along the axis. Sources of laser and electrosurgical energy (18) are available and controlled. An initiation circuit (25) for the laser selectively delivers it before electrosurgery. Prior delivery to target tissue, the laser creates an ionized conductive pathway for electrosurgery. The combined concurrent application of laser and electrosurgery has a mechanism (27) to selectively distribute energy about the axis. A laser deflecting surface (28) or a beam deflector vibrate relative to the axis. A power switch (30) has levels for laser cut and ionization and/or a delay therebetween for electrosurgical coagulation. A wave guide (34) or an array thereof deliver radiation along the axis. A method has steps of directing selectively and concurrently laser and electrosurgery by aiming the axis, controlling laser and electrosurgical energy (18), delivering laser before electrosurgery, forming an ionized conductive pathway for the electrosurgery, distributing the laser about the axis in a predetermined pattern by deflecting the laser in a predetermined pattern generally along but slightly displaced from the axis to direct electrosurgical energy (18) in a predefined pattern on the patient's (11) target tissue. In another possible approach, there are additional steps of delivering the laser radiation (17) as a beam and varying an ionized conductive pathway by refracting or diffracting the laser radiation (17) beam with the mechanism (27) having a beam pattern deflector.

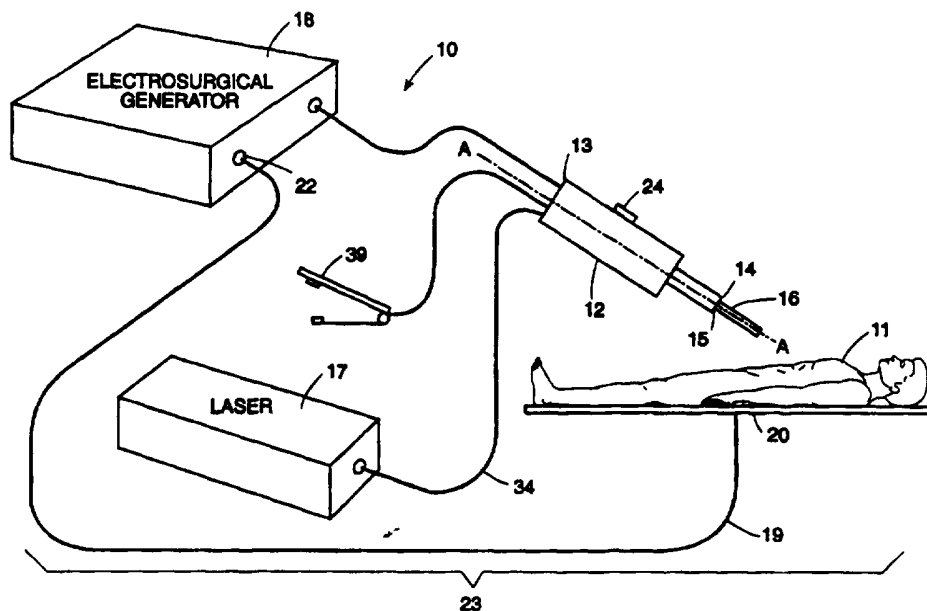

23

FOR THE PURPOSES OF INFORMATION ONLY

Codes used to identify States party to the PCT on the front pages of pamphlets publishing international applications under the PCT.

AT	Austria	GB	United Kingdom	MR	Mauritania
AU	Australia	GE	Georgia	MW	Malawi
BB	Barbados	GN	Guinea	NE	Niger
BE	Belgium	GR	Greece	NL	Netherlands
BF	Burkina Faso	HU	Hungary	NO	Norway
BG	Bulgaria	IE	Ireland	NZ	New Zealand
BJ	Benin	IT	Italy	PL	Poland
BR	Brazil	JP	Japan	PT	Portugal
BY	Belarus	KE	Kenya	RO	Romania
CA	Canada	KG	Kyrgystan	RU	Russian Federation
CF	Central African Republic	KP	Democratic People's Republic of Korea	SD	Sudan
CG	Congo	KR	Republic of Korea	SE	Sweden
CH	Switzerland	KZ	Kazakhstan	SI	Slovenia
CI	Côte d'Ivoire	LI	Liechtenstein	SK	Slovakia
CM	Cameroon	LK	Sri Lanka	SN	Senegal
CN	China	LU	Luxembourg	TD	Chad
CS	Czechoslovakia	LV	Latvia	TG	Togo
CZ	Czech Republic	MC	Monaco	TJ	Tajikistan
DE	Germany	MD	Republic of Moldova	TT	Trinidad and Tobago
DK	Denmark	MG	Madagascar	UA	Ukraine
ES	Spain	ML	Mali	US	United States of America
FI	Finland	MN	Mongolia	UZ	Uzbekistan
FR	France			VN	Viet Nam
GA	Gabon				

LASER-ASSISTED ELECTROSURGERY SYSTEM

1. Field of the Invention This invention relates to electrosurgery combined with laser radiation in a single surgical instrument, and more particularly the selective and/or concurrent delivery from a surgical handpiece of laser energy and electrosurgery with superior benefits to those available separately.

2. Background of the Disclosure Electrosurgery involves the application of radio frequency energy to achieve a tissue effect. The electrosurgical energy is generated by an electrosurgical generator which is applied to the tissue either by monopolar or bipolar circuits. In monopolar, there is a small active electrode directed toward the tissue to be treated and to complete the circuit there is a large patient return electrode applied somewhere to the patient's body. The power density through the patient return electrode is relatively small so that there is no tissue effect thereat. In bipolar, a pair of electrodes are spaced close together with tissue therebetween. In certain circumstances the bipolar electrodes are moveable toward and away from one another.

Electrosurgery can be used for cutting, coagulating or a combination thereof called blend. Coagulation is often described as desiccation of the tissue and fulguration of the tissue. Fulguration is the electrical arcing from the active electrode toward various locations, on the patient's tissue, in the vicinity of the active electrode. Typically when the arcs travel through air, they reach the tissue in a random, non-predictable manner. In many cases arcs leave the active electrode in a trajectory emanating generally along the axis of the active electrode, but before they contact the tissue their paths may vary due to the impedance at the tissue near the active electrode. The resulting fulguration is an uneven or randomly concentrated or irregularly distributed delivery of the energy in each arc, thus producing an uneven or variable coagulation of the tissue desiccated thereat. This is unsatisfactory from the point of view of producing a controlled and preferred level of eschar.

Ionized gases have been used to direct the electrosurgical energy in a more controlled manner. U.S. Patent 4,781,175 deals particularly with that approach. A disadvantage of using ionized gas is the possibility of formation of embolisms within the blood of the patient being treated. In addition, there is the potential for the gas being misdirected and forming a plasma torch either through a leak in the electrosurgical

-2-

handpiece or pencil or when delivered in a laparoscopic procedure within the trocar which provides entry into the body cavity. Another problem with ionized gas is that the electrosurgery and the gas flow are essentially concurrent in the form of a plasma flame that is used to fulgurate and desiccate tissue at which it is aimed. The aiming or
5 positioning of the plasma flame on the desired target tissue is uncertain until activated. Therefore, the pinpointing of the spot at which to initiate the effect is not readily determinable until the electrosurgical energy is delivered.

U.S. Patent 5,011,483 discloses a device which is in the form of a handpiece housing from which electrosurgical and laser energy may be delivered alternatively for
10 selective use thereof. In connection with laparoscopic procedures, an elongate hollow shaft is disclosed for a wave guide to conduct the laser energy. The wave guide may be flexible and one preferred form is a fiber optic. The disclosure of the reference is largely limited to the alternate use of laser or electrosurgery. There is no discussion or disclosure of concurrent delivery.

15 Japanese patent JP57-69853 relates to a laser device which radiates a laser beam to mark the position for subsequent application of laser surgery. No electrosurgery is disclosed and the use of a laser with electrosurgery even for pinpointing is not taught. Japanese patent JP57-69790 has a laser radiation apparatus with a laser oscillator including a light guide and a generator for radiating visible light
20 for positioning. These Japanese patents are used to direct the laser energy and do not teach the concurrent use of laser energy and electrosurgery energy.

U.S. patent 5,324,254 discloses a single laparoscopic instrument capable of supplying either laser radiation or electrosurgical energy. An electrosurgical electrode is provided at the distal end of the instrument for electrosurgical procedures. A side
25 port located near the proximate end of the instrument allows for the passage of a laser fiberoptic bundle, thereby allowing for laser surgery. The patent does not teach the concurrent use of laser energy and electrosurgical energy in a synchronized manner.

An article entitled How Lasers Might Control Lightning Strikes, appearing in Laser Focus World, November 1993, pages 113 - 123, by Zhao, Xin Miao and Daniels,
30 Jean-Claude, discloses how lasers establish an ionized pathway for electric arc transmission. Ordinary optical beams produce little ionization in air or an essentially weak plasma which can be used to direct electrical discharges.

The application of any form of atmospheric ionization to direct electrosurgical beams either statically or dynamically has not been disclosed in the prior technology.

SUMMARY OF THE INVENTION

5 A laser and electrosurgical system allows a surgeon to provide cutting, coagulating, and/or a combination thereof on tissue of a patient. The laser and electrosurgical system preferably has a handpiece with a proximal end to be held and controlled by the surgeon. A distal end may be included on the handpiece from which laser radiation and/or electrosurgical energy may be selectively or concurrently directed
10 to the patient. The proximal and distal ends are most preferably along an axis. An electrosurgical electrode might extend from the distal end along the axis. A source energy for laser radiation most preferably is available at the proximal end and is controlled by the surgeon for delivery of laser radiation from the distal end toward the patient. A source of electrosurgical energy might also be available at the proximal end
15 and may be controlled by the surgeon for transmission of electrosurgical energy from the electrosurgical electrode toward the patient.

A return path is provided for the electrosurgical energy. The return path is connected to receive at least a portion of the transmitted electrosurgical energy from the source of electrosurgical energy toward the patient. A return input for the source
20 of electrosurgical energy is connected to the return path for furnishing a complete circuit between the electrosurgical electrode, the patient, and the source of electrosurgical energy.

A control may be connected to the source energy for laser radiation and to the source of electrosurgical energy for the selective or concurrent application of laser
25 radiation and electrosurgical energy from the distal end.

The laser and electrosurgical system may have in the control an initiation circuit for the source energy for laser radiation, so laser radiation may be selectively delivered from the distal end slightly in advance of the delivery of the electrosurgical energy. The advance delivery of the laser radiation may be used to pinpoint the target tissue to be
30 treated. The delivered laser radiation may also be used to create an ionized conductive pathway along which the electrosurgical energy will be guided.

The laser and electrosurgical system may be configured so the distal end and the electrosurgical electrode are preferably arranged geometrically relative to the

handpiece to provide laser radiation essentially along the axis and from the distal end. This geometry provides for the combined concurrent application of the laser radiation and the electrosurgical energy. The ionized pathway is formed by the laser radiation from the distal end to the patient substantially along the axis to direct the electrosurgical
5 energy.

The laser and electrosurgical system may provide a control which operates a mechanism to selectively distribute, in a predetermined pattern about the axis, the delivered laser radiation from the distal end.

The laser and electrosurgical system may include an electromagnetic radiation
10 deflecting surface arranged to vibrate relative to the axis. This preferably forms a predetermined pattern to achieve a varying ionized conductive pathway generally along but slightly displaced from the axis for thereby directing electrosurgical energy in the predetermined pattern to the patient.

The laser and electrosurgical system may be configured such that the laser
15 radiation is a beam and the mechanism includes a beam pattern deflector. The beam pattern deflector may be an acousto-optic modulator or arrangement of acousto-optic modulators to diffract, refract or reflect the beam.

The laser and electrosurgical system may include in the control for the source
20 energy for laser radiation a power switch which may select between two levels of laser radiation energy delivery. The power switch may include a cutting laser radiation energy level and another level to provide for the ionized conductive pathway. The power switch may also include a time delay mechanism to interpose a preset time period between the initiation of cutting laser radiation and the subsequent delivery of electrosurgical energy for coagulation. The time delay should be sufficient to provide
25 time for cutting with the laser radiation, followed by concurrent electrosurgical coagulation along the ionized conductive pathway to the laser cut tissue.

The laser and electrosurgical system may have the laser radiation energy within
the visible, near-infrared and infrared light spectrum wavelengths. In one possible configuration the laser radiation source provides radiation of a wavelength in the range
30 of between 0.3 to 10.6 microns for establishing through air the ionized conductive pathway as substantially collimated.

A wave guide may be used to deliver the laser radiation from the proximal end to beyond the distal end and generally along the axis. An array of wave guides may

also be used to deliver the laser radiation from the proximal end to beyond the distal end and generally along the axis.

The laser and electrosurgical system may include a handpiece which is generally shaped like a pistol grip, where the pistol grip depends near the proximal end and is therefore at an angle to the axis which extends from the distal end in the direction
5 which the electrode is pointed.

The laser and electrosurgical system may have an electrosurgical electrode which is flexible and elongate for endoscopic or laparoscopic use within a cannula passing through the patient's body wall and into a cavity therein.

10 The laser and electrosurgical system may have its control located on the handpiece between the proximal and distal ends. The control may also be located on a foot pedal.

The laser and electrosurgical system may have a source of electrosurgical energy which includes an electrosurgical generator and a return path which is carried
15 on the handpiece for bipolar electrosurgery on the tissue of the patient. Alternatively, the return path may include a return pad connected to the patient for receiving electrosurgical energy during monopolar electrosurgery on the tissue of the patient.

A method for providing cutting, coagulating, and/or a combination thereof on tissue of a patient with a laser and electrosurgical system may include the following
20 step of directing selectively and at least concurrently laser radiation and electrosurgical energy from a handpiece with its proximal and distal ends along an axis by aiming the distal end thereof along the axis from which laser radiation and electrosurgical energy may be at least in part concurrently directed. A further step might be controlling a source energy for laser radiation available at the proximal end of the handpiece by the
25 surgeon for first delivering laser radiation from the distal end. Controlling a source of electrosurgical energy available at the proximal end of the handpiece by the surgeon for transmission of electrosurgical energy from a electrosurgical electrode at the distal end may be yet another step of the method. Then the step of connecting a control to a source energy for laser radiation and to a source of electrosurgical energy so the
30 control is preferably arranged for the concurrent application of laser radiation and electrosurgical energy from the distal end.

The method can also include the additional step of initiating the laser radiation delivered from the distal end concurrently or slightly in advance of the delivery of the

electrosurgical energy so that the laser radiation forms an ionized conductive pathway along which the electrosurgical energy will be guided for pinpointing the target tissue to be treated.

The method may include the additional step of guiding the electrosurgical
5 energy by arranging the distal end and the electrosurgical electrode geometrically relative to the handpiece for providing laser radiation essentially along the axis and from the distal end for the combined concurrent application of the laser radiation and the electrosurgical energy. Then the added step of ionizing a conductive pathway with laser radiation from the distal end to the patient along the axis to direct the flow of
10 electrosurgical energy is preferably performed.

The method may include the additional step of distributing the laser radiation available at the proximal end for delivery about the axis in a predetermined pattern from the distal end with a mechanism. In one possible configuration, there is an added step in which the mechanism can deflect the laser radiation to create a varying ionized
15 conductive pathway with an electromagnetic radiation deflecting surface that vibrates in a predetermined pattern generally along but slightly displaced from the axis to direct electrosurgical energy in a predefined pattern on the patient's target tissue. In another possible approach, there are additional steps of delivering the laser radiation as a beam and varying an ionized conductive pathway by refracting or diffracting the laser radiation
20 beam with the mechanism having a beam pattern deflector.

The method of initiating the laser radiation slightly in advance of the delivery of the electrosurgical energy may be augmented with the additional steps of controlling the laser radiation initially with a switch having two levels of delivery. A first level of delivery may be a cutting level and a second level may be an ionizing conductive
25 pathway level. This may provide for delaying the subsequent delivery of electrosurgical energy for coagulation sufficiently for providing time for first cutting with the laser radiation and thereafter enabling, with the switch, the concurrent electrosurgical fulguration along the later ionized conductive pathway to the coagulate.

The method may also include the additional step of using laser radiation in the
30 visible, near-infrared and infrared light spectrum wavelengths provided by the source of laser radiation. There may also be the additional step of using a wave guide or an array of wave guides for delivery of the laser radiation from the proximal end to beyond the distal end and generally along the axis.

-7-

The method may include the additional step of using the handpiece, which is generally shaped like a pistol grip, by aiming along the axis extending from the distal end in the direction in which the electrode is pointed while having the pistol grip at an angle ergonomically comfortable for surgery. The method may also include the
5 additional step of flexing into position an elongate electrosurgical electrode for endoscopic or laparoscopic use in a cannula placed through the patient's body wall and into a cavity therein. There may be the additional step of using the control located on the handpiece between the proximal and distal ends, or using the control located on a foot pedal.

BRIEF DESCRIPTION OF THE DRAWINGS

Figure 1 is a schematic drawing of the laser and electro-surgical system showing a monopolar configuration of the elements.

Figure 2 is a schematic drawing of the laser and electro-surgical system showing
5 a bipolar configuration of the elements.

Figure 3 is a pulse timing graph which illustrates the timing between a laser pulse and successive electro-surgical pulses during a coagulation mode.

Figure 4 is a schematic drawing of a portion of the laser and electro-surgical system which illustrates the use of an electromagnetic radiation deflecting surface.

10 Figure 5 is a schematic drawing of a portion of the laser and electro-surgical system which illustrates the use of an acousto-optic modulator.

Figure 6 is a schematic drawing of a portion of the laser and electro-surgical system which illustrates the use of a power switch.

15 Figure 7 is a pulse timing graph which illustrates the timing between a laser pulse and successive electro-surgical pulses during a laser cut mode.

DETAILED DESCRIPTION OF THE INVENTION

A laser and electro-surgical system 10 is shown in perspective in Figure 1 and allows a surgeon to provide cutting, coagulating, and/or a combination thereof on
20 tissue of a patient 11. The laser and electro-surgical system 10 has a handpiece 12 with a proximal end 13 to be held and controlled by the surgeon. A distal end 14 on the handpiece 12 has a port 15 from which laser radiation and/or electro-surgical energy are selectively or concurrently directed to the patient 11. The proximal and distal ends 13 and 14 are along an axis "A". An electro-surgical electrode 16 extends from the distal
25 end 14 along the axis "A". A source energy for laser radiation 17 preferably manufactured by Coherent, Inc., located in Palo Alto, CA, and sold as model Infinity is connected to be available at the proximal end 13 and is controlled by the surgeon for delivery of laser radiation from the distal end 14 toward the patient 11. A source of
30 electro-surgical energy 18 preferably manufactured by Valleylab, located in Boulder, CO, and sold as model Force 40, is connected electrically to be available at the proximal end 13 and may be controlled by the surgeon for transmission of electro-surgical energy from the electro-surgical electrode 16 toward the patient 11.

A return path 19 is provided for the electrosurgical energy; the return path 19 may be in a monopolar or bipolar circuit as schematically shown in Figures 1 and 2, respectively. Specifically, in Figure 1 there is a return pad 20 and in Figure 2 there is a bipolar return electrode 21 each to complete their respective circuits. The return path 5 19 is connected to receive at least a portion of the transmitted electrosurgical energy from the source of electrosurgical energy 18 and then the patient 11. A return input 22 for the source of electrosurgical energy 18 is connected to the return path 19 for furnishing a complete circuit 23 between the electrosurgical electrode 16, the patient 11, and the source of electrosurgical energy 18.

10 A control 24 is connected to the source energy for laser radiation 17 and to the source of electrosurgical energy 18 for the selective or concurrent application of laser radiation and electrosurgical energy from the distal end 14. The advance delivery of the laser radiation may be used to pinpoint the target tissue to be treated when the laser radiation is within the visible spectrum. The delivered laser radiation is also used 15 to create an ionized conductive pathway along which the electrosurgical energy will be guided.

The laser and electrosurgical system 10 has in the control 24 an initiation circuit 25 for the source energy for laser radiation 17, so laser radiation may be selectively delivered from the distal end 14 concurrently or slightly in advance of the delivery of the 20 electrosurgical energy. The laser energy will be modulated at a rate between 10 Hz. and 31 kHz., and may be synchronized to deliver the pulse between zero and five microseconds ahead of the electrosurgical pulse. This allows the electrosurgical energy to follow the ionized pathway created by the laser energy. In Figure 3, one possible pulse diagram is shown for the laser pulse and the electrosurgical pulse. The laser 25 pulse occurs at t_1 and the electrosurgical pulse occurs at $t_1 + .000005$ seconds.

When the laser is being used to create an ionized pathway, the laser energy must be controlled in order to avoid undesired tissue effects. The duty cycle of the laser will be kept in the range of 10^{-5} to 10^{-8} . Energy density delivered to any single area of tissue from the laser pulse should not exceed 26 J/cm² for wavelengths 30 between 1.06 and 10.6 microns, and 17 J/cm² for wavelengths around and below .53 microns.

The laser and electrosurgical system 10 is configured so the distal end 14 and the electrosurgical electrode 16 are preferably arranged geometrically relative to the

-10-

handpiece 12 to provide laser radiation essentially along the axis "A" and from the distal end 14. This geometry provides for the combined concurrent application of the laser radiation and the electrosurgical energy. The ionized pathway is formed by the laser radiation from the distal end 14 to the patient 11 substantially along the axis "A" to
5 direct the electrosurgical energy therealong.

The laser and electrosurgical system 10 provides a button 26 which operates a mechanism 27, see Figure 4, to selectively distribute in a predetermined pattern about the axis "A" the laser radiation from the distal end 14. The mechanism 27 includes an electromagnetic radiation deflecting surface 28 arranged to vibrate relative to the axis
10 "A". This forms a predetermined pattern to achieve a varying ionized conductive pathway generally along but slightly displaced from the axis "A" for thereby directing electrosurgical energy in the predetermined pattern to the patient 11. The mechanism 27 may alternatively include a beam pattern deflector 29. The beam pattern deflector 29 may be an acousto-optic modulator or arrangement of acousto-optic modulators to
15 diffract, refract or reflect the laser radiation.

In another alternate, the laser and electrosurgical system 10 includes in the control 24 for the source energy for laser radiation 17 a power switch 30 which may select between two levels of laser radiation energy delivery. This may be accomplished by changing the duty cycle of the laser. The power switch 30 includes a cutting laser
20 radiation energy level "C" and another level "I" to provide for the ionized conductive pathway. The power switch 30 also includes an electronic time delay mechanism 31 to interpose a preset time period, shown in Figure 7, between the initiation of cutting laser radiation 32 and the subsequent delivery of electrosurgical energy 33 for coagulation. The time delay should be sufficient to provide time for cutting with the laser
25 radiation, followed by concurrent electrosurgical coagulation along the ionized conductive pathway to the laser cut tissue.

The laser and electrosurgical system 10 has the laser radiation energy within the range of visible, near-infrared and infrared light spectrum wavelengths. The laser radiation source 17 provides radiation of wavelengths in the range of between 0.3 to
30 10.6 microns for establishing through air the ionized conductive pathway as substantially collimated.

A wave guide 34, shown in Figure 1, is used to deliver the laser radiation from the proximal end 13 to beyond the distal end 14 and generally along the axis "A". An

array of wave guides 35, shown in Figure 2 may alternatively be used to deliver the laser radiation from the proximal end 13 to beyond the distal end 14 and generally along the axis "A".

5 The laser and electrosurgical system 10 includes on the handpiece 12 a pistol grip 36 which depends near the proximal end 13 and is therefore at an angle 37 to the axis "A" which extends from the distal end 14 in the direction which the electrode 16 is pointed.

10 The laser and electrosurgical system 10 has alternatively in Figure 2 an electrosurgical electrode support 38 which is flexible and elongate for endoscopic or laparoscopic use within a cannula (not shown) passing through the patient's body wall and into a cavity therein.

The laser and electrosurgical system 10 has its control located on the handpiece between the proximal and distal ends 13 and 14. The control may also be located on the pistol grip 36 or at a foot pedal 39.

15 A method for providing cutting, coagulating, and/or a combination thereof on tissue of the patient 11 with a laser and electrosurgical system 10 includes the following step of directing selectively and at least concurrently laser radiation and electrosurgical energy from the handpiece 12 with its proximal and distal ends, 13 and 14, along an axis "A" by aiming the distal end 14 thereof along the axis "A" from which laser radiation and electrosurgical energy may be at least in part concurrently directed. A further step might be controlling the source energy for laser radiation 17 available at the proximal end 13 of the handpiece by the surgeon for first delivering laser radiation from the distal end 14. Controlling a source of electrosurgical energy available at the proximal end 13 of the handpiece 12 by the surgeon for transmission of electrosurgical energy from a
20 electrosurgical electrode 16 at the distal end 14 may be yet another step of the method. Then may follow the step of connecting the control 24 to a source energy for laser radiation 17 and to a source of electrosurgical energy 18 so the control is preferably arranged for the concurrent application of laser radiation and electrosurgical energy from the distal end 14.

30 The method also includes the additional step of initiating the laser radiation delivered from the distal end 14 concurrently or slightly in advance of the delivery of the electrosurgical energy so that the laser radiation forms an ionized conductive pathway

-12-

along which the electrosurgical energy will be guided for pinpointing the target tissue to be treated.

The method includes the additional step of guiding the electrosurgical energy by arranging the distal end 14 and the electrosurgical electrode 16 geometrically relative to the handpiece 12 for providing laser radiation essentially along the axis "A" and from the distal end 14 for the combined concurrent application of the laser radiation and the electrosurgical energy. Then the added step of ionizing a conductive pathway with laser radiation from the distal end 14 to the patient 11 along the axis "A" to direct the flow of electrosurgical energy is performed.

10 The method includes the additional step of distributing the laser radiation available at the proximal end for delivery about the axis "A" in a predetermined pattern from the distal end 14 with the mechanism 27. In one possible variation, there is an added step in which the mechanism 27 can deflect the laser radiation to create a varying ionized conductive pathway with an electromagnetic radiation deflecting surface 15 28 that vibrates in a predetermined pattern generally along but slightly displaced from the axis "A" to direct electrosurgical energy in a predefined pattern on the patient's 11 target tissue. In another possible approach, there are additional steps of delivering the laser radiation as a beam and varying an ionized conductive pathway by refracting or diffracting the laser radiation beam with the mechanism 27 having a beam pattern 20 deflector 29.

The method of initiating the laser radiation slightly in advance of the delivery of the electrosurgical energy is augmented with the additional steps of controlling the laser radiation initially with the switch 30 having two levels of delivery. A first level of delivery "C" may be a cutting level and a second level "I" may be an ionizing conductive 25 pathway level. This may provide for delaying the subsequent delivery of electrosurgical energy for coagulation sufficiently for providing time for first cutting with the laser radiation and thereafter enabling, with the switch, the concurrent electrosurgical fulguration along the later ionized conductive pathway to the coagulate.

The method also includes the additional step of using laser radiation in the 30 visible, near-infrared and infrared light spectrum wavelengths provided by the source of laser radiation 17. There may also be the additional step of using the wave guide 34 or the array of wave guides 35 for delivery of the laser radiation from the proximal end 13 to beyond the distal end 14 and generally along the axis "A".

-13-

The method includes the additional step of using the handpiece, which is generally shaped like the pistol grip 36, by aiming along the axis "A" extending from the distal end 14 in the direction in which the electrode 16 is pointed while having the pistol grip 16 at an angle 37 ergonomically comfortable for surgery. The method also includes the additional step of flexing into position the elongate electrosurgical electrode support 38 for endoscopic or laparoscopic use in the cannula placed through the patient's body wall and into a cavity therein. There is the additional step of using the control 24 located on the handpiece 12 between the proximal and distal ends 13 and 14, or controlling with a foot pedal 39.

10 The claims which follow seek to cover the described embodiments and their equivalents. The concept in its broadest scope covers the apparatus and methods for concurrent and simultaneous application of laser and electrosurgical energy. It is to be understood that the concept is subject to many modifications without departing from the spirit and scope of the claims as recited herein.

CLAIMS

1. A laser and electrosurgical system 10 for a surgeon to provide cutting, coagulating, and/or a combination thereof on tissue of a patient 11, comprising:
- 5 a handpiece 12 having a proximal end 13 to be held and controlled by the surgeon and a distal end 14 from which laser radiation and/or electrosurgical energy may be selectively or concurrently directed to the patient, the proximal and distal ends 13 and 14 along an axis A;
- 10 an electrosurgical electrode 16 extending from the distal end 14 along the axis;
- a source energy for laser radiation 17 available at the proximal end 13 and controlled by the surgeon for delivery of laser radiation from the distal end 14 toward the patient;
- 15 a source of electrosurgical energy 18 available at the proximal end 13 and controlled by the surgeon for transmission of electrosurgical energy from the electrosurgical electrode 16 toward the patient 11;
- a return path 19 for the electrosurgical energy, the return path connected to receive at least a portion of the transmitted electrosurgical energy from the source of electrosurgical energy toward the patient;
- 20 a return input 22 on the source of electrosurgical energy 18, the return input connected to the return path 19 for furnishing a complete circuit 23 between the electrosurgical electrode 16, the patient 11 and the source of electrosurgical energy 18, and
- 25 a control 24 connected to the source energy for laser radiation 17 and to the source of electrosurgical energy 18 for the selective or concurrent application of laser radiation and electrosurgical energy from the distal end 14.
2. The laser and electrosurgical system of Claim 1 wherein the control 24 includes an initiation circuit 25 for the source energy for laser radiation 17 so laser radiation can be selectively delivered from the distal end 14 slightly in advance of the
- 30 delivery of the electrosurgical energy, the advance delivery of the laser radiation used to pinpoint the target tissue to be treated or the delivered laser radiation creating an ionized conductive pathway along which the electrosurgical energy will be guided.

3. The laser and electrosurgical system of Claim 1 wherein the distal end 14 and the electrosurgical electrode 16 are arranged geometrically relative to the handpiece 12 to provide laser radiation essentially along the axis A and from the distal end 14 for the combined concurrent application of the laser radiation and the electrosurgical energy so that the ionized pathway is formed by the laser radiation from the distal end 14 to the patient 11 substantially along the axis A to direct the electrosurgical energy.

4. The laser and electrosurgical system of Claim 1 wherein the control 24 operates a mechanism 27 to selectively distribute in a predetermined pattern about the axis A the delivered laser radiation from the distal end 14 and the mechanism 27 includes an electromagnetic radiation deflecting surface 28 arranged to vibrate relative to the axis A to form the predetermined pattern to achieve a varying ionized conductive pathway generally along but slightly displaced from the axis A for thereby directing electrosurgical energy in the predetermined pattern to the patient 11.

5. The laser and electrosurgical system of Claim 4 wherein the laser radiation is a beam and the mechanism includes a beam pattern deflector 29 wherein the beam pattern deflector is an acousto-optic modulator or arrangement of acousto-optic modulators to diffract, refract or reflect the beam.

6. The laser and electrosurgical system of Claim 2 wherein the control 24 for the source energy for laser radiation 17 has a power switch 30 for selecting between two levels of laser radiation energy delivery, the power switch including a cutting laser radiation energy level and the ionized conductive pathway level of laser radiation energy.

7. The laser and electrosurgical system of Claim 6 wherein the power switch 30 includes a time delay mechanism 31 to interpose a preset time period between the initiation of cutting laser radiation 32 and the subsequent delivery of electrosurgical energy 33 for coagulation, the preset time sufficient to provide time for cutting with the laser radiation, the power switch 30 thereafter enables concurrent electrosurgical coagulation along the ionized conductive pathway to the laser cut tissue.

8. The laser and electrosurgical system of Claim 1 wherein a wave guide 34 delivers the laser radiation from the proximal end 13 to beyond the distal end 14 and generally along the axis, or wherein an array of wave guides 35 deliver the laser

-16-

radiation from the proximal end 13 to beyond the distal end 14 and generally along the axis.

9. The laser and electro-surgical system of Claim 1 wherein the electro-surgical electrode 16 is attached to a support 38 which is flexible and elongate
5 for endoscopic or laparoscopic use within a cannula passing through the patient's body wall and into a cavity therein.

10. The laser and electro-surgical system of Claim 1 wherein the source of electro-surgical energy 18 includes an electro-surgical generator and the return path 19 includes a return pad 20 connected to the patient 11 for receiving electro-surgical
10 energy during monopolar electro-surgery on the tissue of the patient 11.

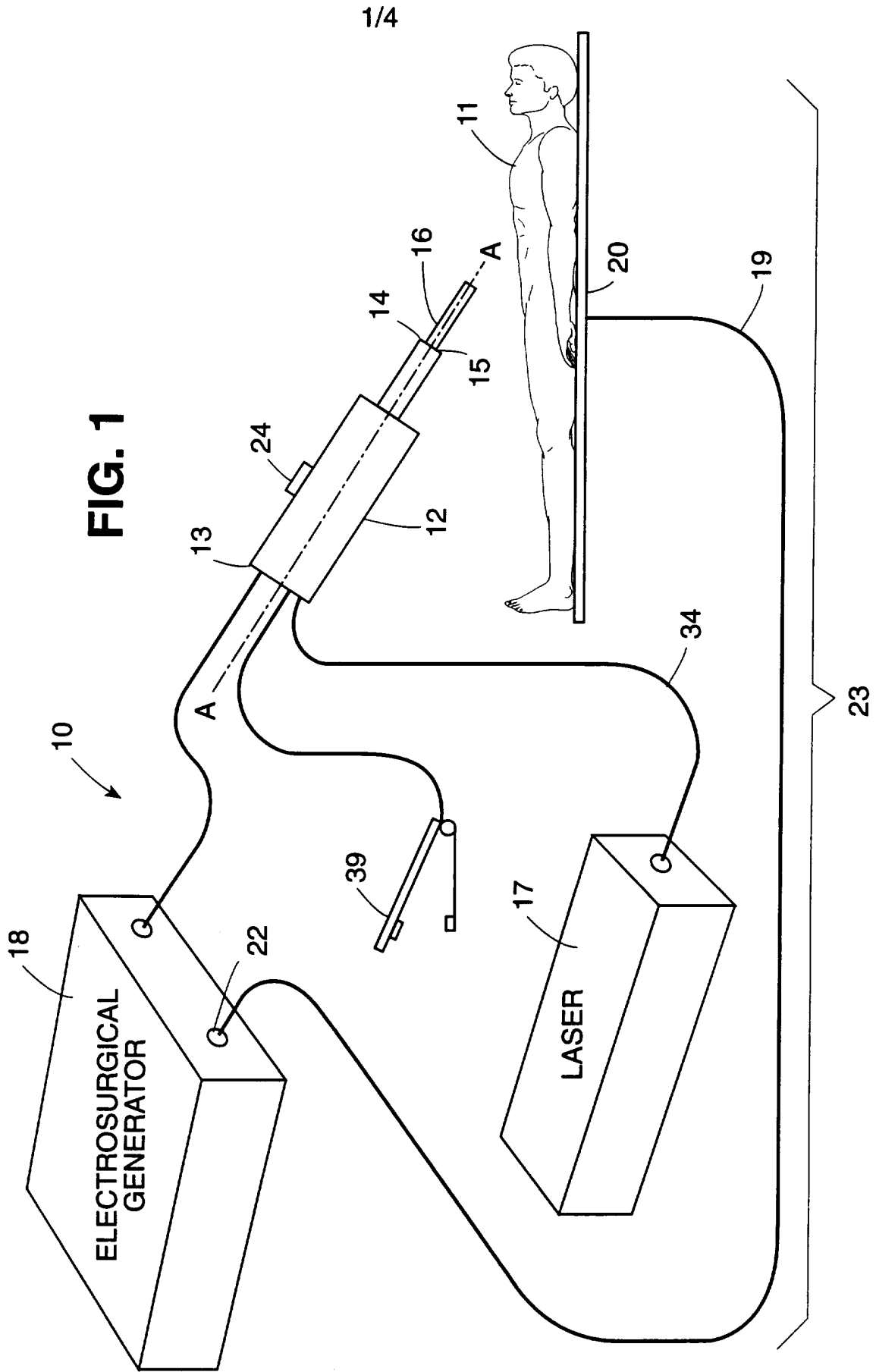

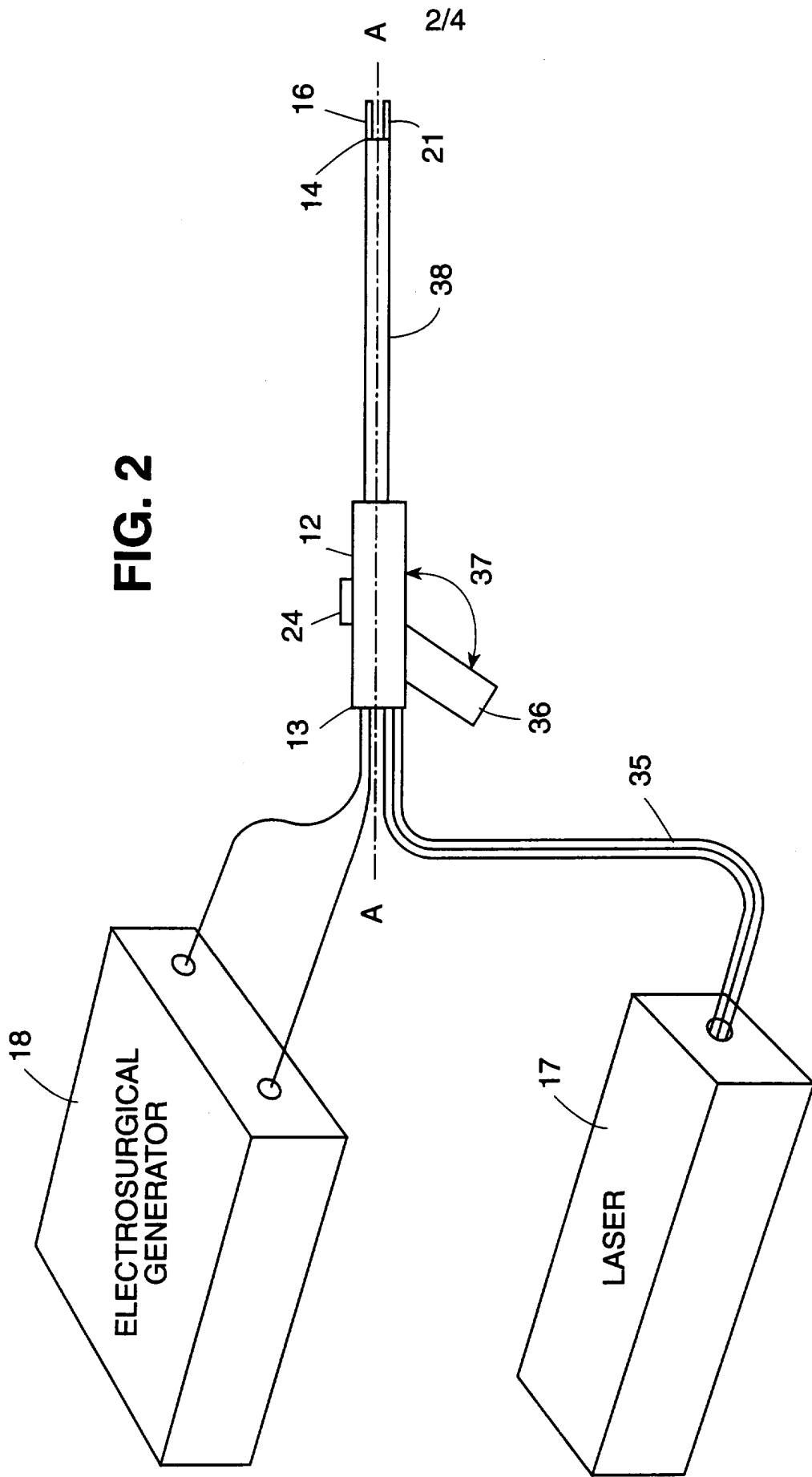

FIG. 3

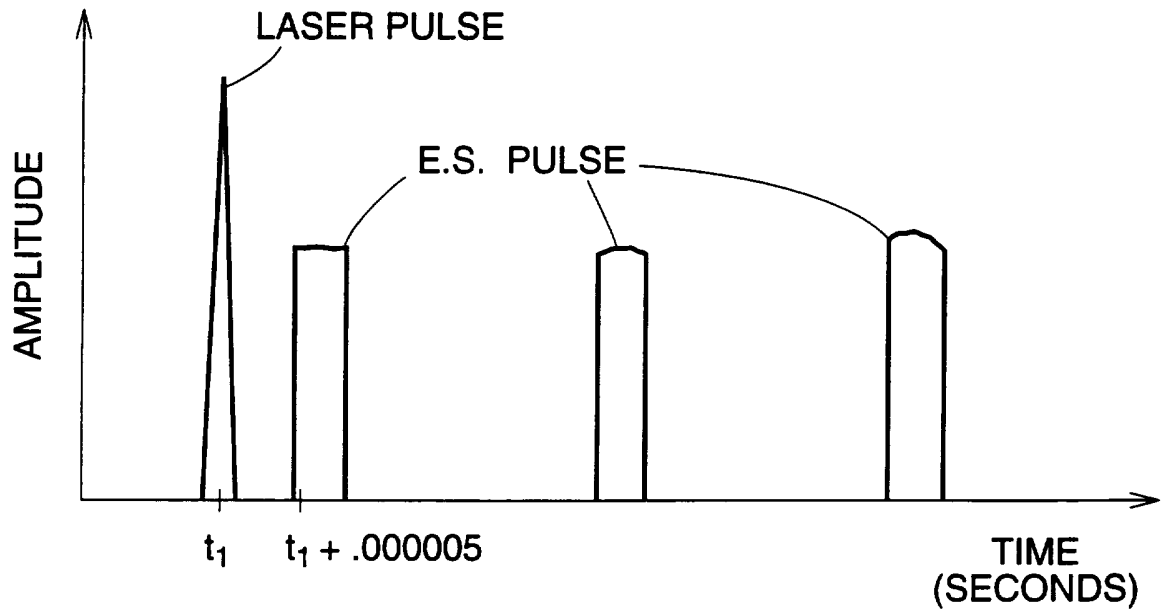
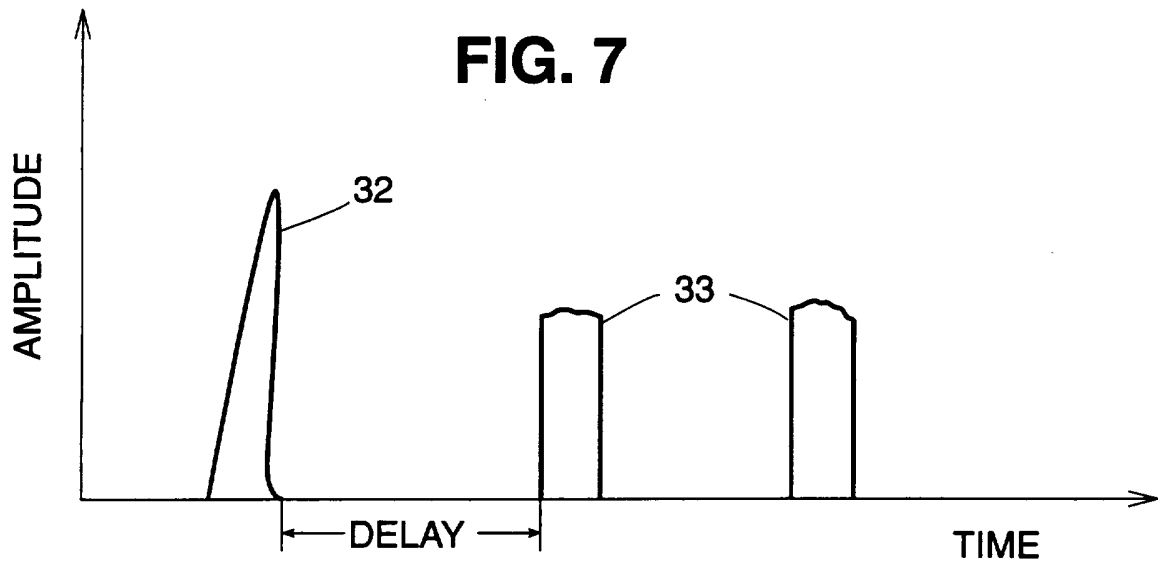
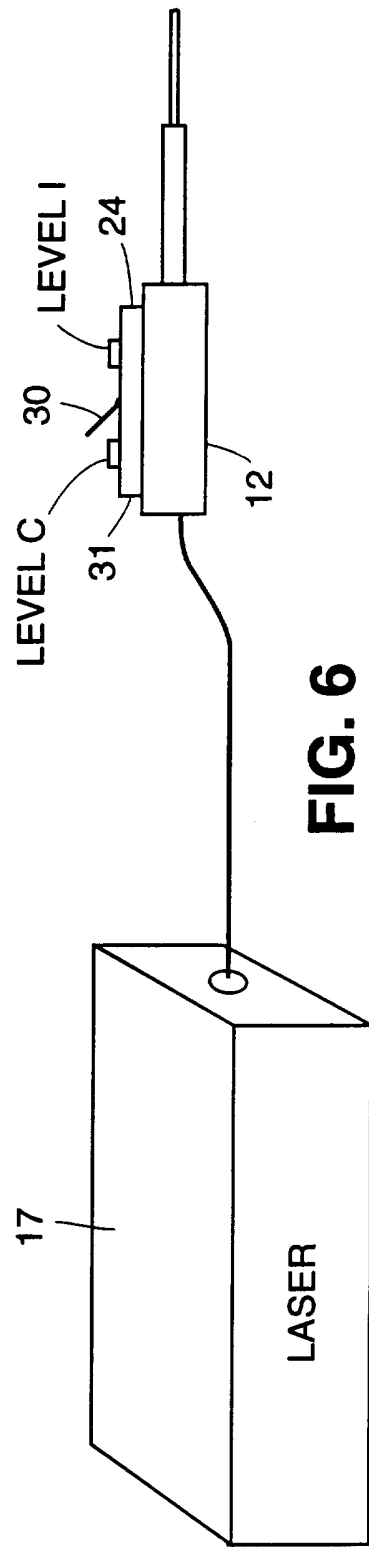
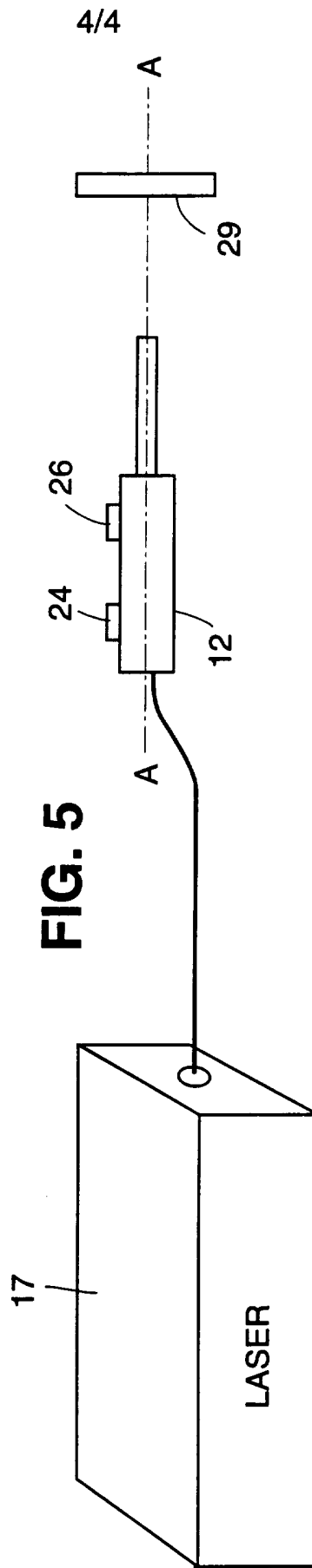
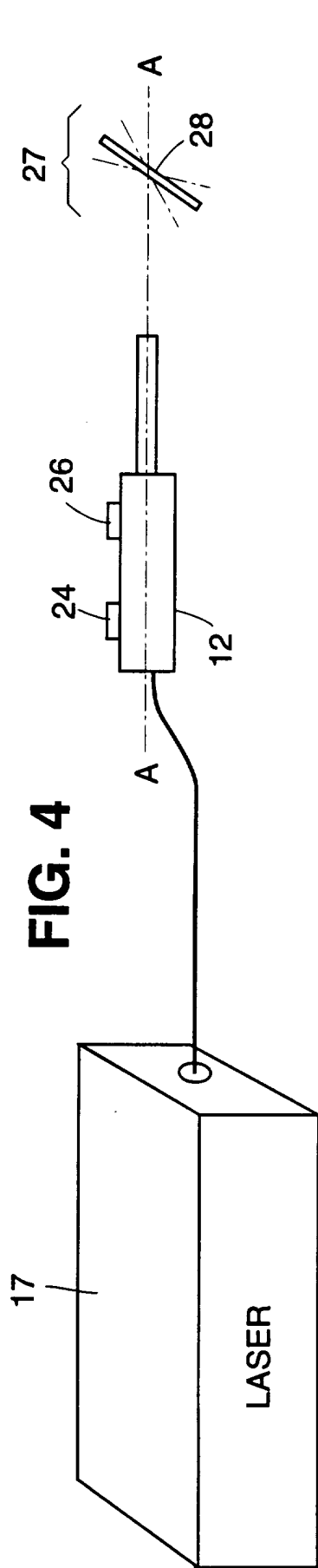

FIG. 7





INTERNATIONAL SEARCH REPORT

International Application No
PCT/IB 95/00546

A. CLASSIFICATION OF SUBJECT MATTER
 IPC 6 A61B17/39 A61B17/36

According to International Patent Classification (IPC) or to both national classification and IPC

B. FIELDS SEARCHED

Minimum documentation searched (classification system followed by classification symbols)
 IPC 6 A61B

Documentation searched other than minimum documentation to the extent that such documents are included in the fields searched

Electronic data base consulted during the international search (name of data base and, where practical, search terms used)

C. DOCUMENTS CONSIDERED TO BE RELEVANT

Category *	Citation of document, with indication, where appropriate, of the relevant passages	Relevant to claim No.
A	FR,A,2 513 109 (COMPAGNIE INDUSTRIELLE DES LASERS) 25 March 1983 see claim 1 ---	1
A	DE,A,34 06 294 (HUBMANN) 5 September 1985 see page 28, line 32 - page 29, line 5 ---	1
A	DE,A,37 23 674 (MÜLLER) 26 January 1989 see column 3, line 21 - line 33 see column 4, line 45 - line 48 ---	1
A	US,A,5 011 483 (SLEISTER) 30 April 1991 cited in the application see claim 1 ---	1
A	US,A,5 267 994 (GENTELIA ET AL.) 7 December 1993 see claim 1 -----	1

Further documents are listed in the continuation of box C. Patent family members are listed in annex.

* Special categories of cited documents :

<p>"A" document defining the general state of the art which is not considered to be of particular relevance</p> <p>"E" earlier document but published on or after the international filing date</p> <p>"L" document which may throw doubts on priority claim(s) or which is cited to establish the publication date of another citation or other special reason (as specified)</p> <p>"O" document referring to an oral disclosure, use, exhibition or other means</p> <p>"P" document published prior to the international filing date but later than the priority date claimed</p>	<p>"T" later document published after the international filing date or priority date and not in conflict with the application but cited to understand the principle or theory underlying the invention</p> <p>"X" document of particular relevance; the claimed invention cannot be considered novel or cannot be considered to involve an inventive step when the document is taken alone</p> <p>"Y" document of particular relevance; the claimed invention cannot be considered to involve an inventive step when the document is combined with one or more other such documents, such combination being obvious to a person skilled in the art.</p> <p>"&" document member of the same patent family</p>
--	--

Date of the actual completion of the international search	Date of mailing of the international search report
23 January 1996	26. 01. 96

Name and mailing address of the ISA European Patent Office, P.B. 5818 Patentlaan 2 NL - 2280 HV Rijswijk Tel. (+ 31-70) 340-2040, Tx. 31 651 epo nl, Fax: (+ 31-70) 340-3016	Authorized officer Glas, J
--	-----------------------------------

1

INTERNATIONAL SEARCH REPORT

Information on patent family members

International Application No PCT/IB 95/00546
--

Patent document cited in search report	Publication date	Patent family member(s)	Publication date
FR-A-2513109	25-03-83	NONE	
DE-A-3406294	05-09-85	NONE	
DE-A-3723674	26-01-89	DE-A- 3876970 WO-A- 8900408 EP-A, B 0324844	04-02-93 26-01-89 26-07-89
US-A-5011483	30-04-91	NONE	
US-A-5267994	07-12-93	NONE	