



(11) **EP 2 199 453 A1**

(12) **EUROPEAN PATENT APPLICATION**

(43) Date of publication:
23.06.2010 Bulletin 2010/25

(51) Int Cl.:
D06F 58/16^(2006.01) D06F 58/20^(2006.01)

(21) Application number: **08171991.6**

(22) Date of filing: **17.12.2008**

(84) Designated Contracting States:
AT BE BG CH CY CZ DE DK EE ES FI FR GB GR HR HU IE IS IT LI LT LU LV MC MT NL NO PL PT RO SE SI SK TR
Designated Extension States:
AL BA MK RS

- **Da Riol, Daniele**
I-33084, Cordenons (PN) (IT)
- **Pasut, Fabio**
I-33170, Pordenone (PN) (IT)
- **Bisaro, Michele**
I-33097, Spilimbergo (PN) (IT)

(71) Applicant: **Electrolux Home Products Corporation N.V.**
1930 Zaventem (BE)

(74) Representative: **Maccalli, Marco et al**
Maccalli & Pezzoli S.r.l.,
Via Settembrini, 40
20124 Milano (IT)

(72) Inventors:
• **Sartor, Luciano**
I-31015, Conegliano (TV) (IT)

(54) **A household appliance**

(57) A household appliance (100) comprises a cabinet (105) provided with a worktop (110) defining a surface (130) having a plurality of apertures (135) in fluid communication with an air conveying system (245)

adapted to deliver a flow of air through said apertures. A liquid drainage arrangement (255,260,405,410,705, 710) is provided, adapted to drain liquid deposits from said worktop.

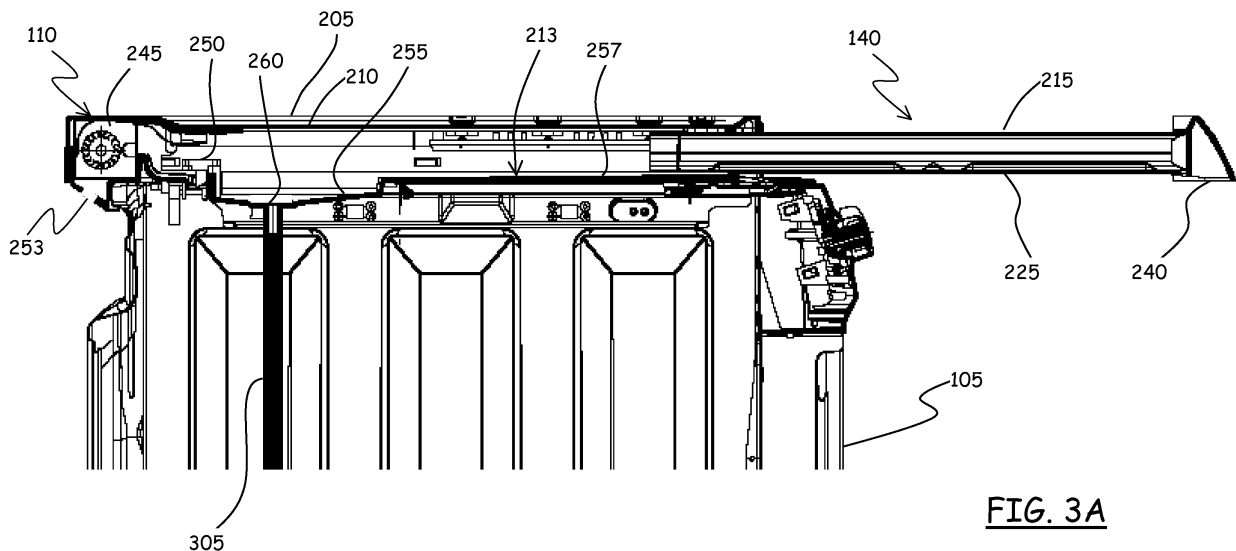

EP 2 199 453 A1

Description

[0001] The present invention relates in general to the field of household appliances, and more particularly to laundry washing and/or drying appliances like laundry washers, dryers and washer-dryers.

[0002] Garments made of delicate textile materials, such as cashmere, are not adapted to undergo regular drying treatments in a tumble dryer, owing to the mechanical stresses, mainly in the form of impacts, which the textile fibres would be subject to. More gentle drying treatments are thus recommendable for these delicate textiles, such as line drying or flat drying, which on the other hand are rather time-consuming processes.

[0003] The solutions disclosed in the European patent applications EP 1845185 and EP 1854916, both in the name of the present Applicant, are effective in eliminating the above cited drawbacks, by providing a household appliance that comprises a cabinet with a worktop defining a drying surface featuring a plurality of apertures, each one of which is fluidly connected with conveying means adapted to deliver a flow of air towards and through said apertures, for gently but rapidly drying garments that are laid upon the worktop drying surface.

[0004] The Applicant has observed that in the solutions disclosed in EP 1845185 and EP 1854916 some problems may arise in case, due for example to a misconduct of the user, very wet garments are laid on the drying surface: the water dripping from the garments, passing through the apertures in the worktop drying surface, falls on the bottom of the worktop, and there it remains and accumulates, forming a water deposit, a thing that is undesirable under many respects. A similar problem is encountered when water is accidentally poured onto the worktop drying surface.

[0005] The present invention proposes an improvement to the solutions set forth in the two cited European patent applications, suitable to overcome the abovementioned problems.

[0006] According to an aspect of the present invention, a household appliance is provided, comprising a cabinet provided with a worktop defining a surface having a plurality of apertures in fluid communication with an air conveying system adapted to deliver a flow of air through said apertures. A liquid drainage arrangement is provided in the household appliance, adapted to drain possible liquid deposits from said worktop.

[0007] In particular, said liquid drainage arrangement may comprise a liquid drainage hole provided in the worktop. The worktop may comprise a base shaped so as to cause liquid deposits to converge towards the liquid drainage hole.

[0008] In embodiments of the present invention, the liquid drainage hole may be fluidly connected to a washing liquid discharge pump of the household appliance provided for discharging washing liquid from a tub of the household appliance, for example the tub of a washing machine or of a washer/dryer.

[0009] A liquid drainage conduit may be connected at one end thereof to the liquid drainage hole, and, at an another end, the liquid drainage conduit may terminate at a user-accessible location, of said cabinet, for example a location where a washing liquid filter is usually located.

[0010] In other embodiments of the present invention, the liquid drainage hole may be fluidly connected to a condense liquid collection arrangement provided in the household appliance, for example a condenser or heat-pump dryer or washer/dryer, for collecting condense liquid from the condenser of a laundry drying circuit.

[0011] In particular, the liquid collection arrangement may comprise a condense liquid collection tank fluidly connected to a condense liquid collection tray below the condenser. The liquid drainage hole may be fluidly connected to the liquid collection tank, and/or it may be located above an opening in the liquid collection tank so that liquid deposits may fall through the liquid drainage and said opening hole into the liquid collection tank, and/or where the liquid collection tank is accommodated within a tank container fluidly connected to the liquid collection tray, in such a way that liquid overflowing from the liquid connection tank is discharged into the liquid collection tray, the liquid drainage hole may be fluidly connected to the tank container. Also, the liquid drainage hole may be fluidly connected directly to the condense liquid collection tray.

[0012] The household appliance may comprise a steam generation arrangement including a steam generator and a steam generator water tank, and the liquid drainage hole may be fluidly connected to the steam generator water tank.

[0013] Preferably, the surface with apertures is in metal. More preferably, the surface with apertures has upward protrusions between said apertures so as to keep garments laid on said surface distanced from said apertures.

[0014] These and other features and advantages of the present invention will become apparent by reading the following detailed description of some embodiments thereof. For better intelligibility, the description should be read in conjunction with the attached drawings, wherein:

Figure 1 is a perspective view of a household appliance with a worktop defining a drying surface and wherein a solution according to an embodiment of the present invention can be advantageously implemented;

Figure 2 is an exploded view of the worktop of the household appliance of **Figure 1** according to an embodiment of the present invention;

Figure 3A is a partial, side cross-sectional view of the household appliance with the worktop of **Figure 2**;

Figure 3B shows, schematically and in enlarged scale, a detail of a worktop drying surface according to an embodiment of the present invention;

Figure 4 schematically shows a worktop water de-

posit drainage arrangement according to an embodiment of the present invention;

Figure 5 schematically shows a worktop water deposit drainage arrangement according to another embodiment of the present invention; and

Figures 6 and **7** schematically shows a worktop water deposit drainage arrangement according to still another embodiment of the present invention.

[0015] In **Figure 1** there is shown a household appliance **100**, in particular a household appliance for washing (e.g., a domestic washing machine) and/or drying clothes (e.g. a domestic dryer or washer/dryer), wherein a solution according to an embodiment of the present invention is advantageously implemented.

[0016] As described in the two cited European patent applications EP 1845185 and EP 1854916, which are incorporated herein by reference, the household appliance **100** comprises an outer casing or cabinet **105** with a worktop **110** and a front panel carrying operational input and setting controls, a drum (not visible in **Figure 1**) rotatably supported inside the cabinet **105** and adapted to be loaded with the items to be washed and/or dried, an opening in a front wall **115** of the cabinet **105** for loading and unloading the items into and from the drum, and a door **125** hinged to the front wall **115** for closing said opening.

[0017] The worktop **110** of the household appliance **100** comprises a drying surface **130** having a plurality of apertures **135**, each one of which is fluidly connected to conveying means adapted to direct a flow of air through said apertures **135**, for drying garments that are placed on the drying surface **130**. Garments to be dried can be placed on the drying surface **130**, and, by activating the conveying means, air is caused to flow through the apertures or perforations **135** so as to hit the garments placed thereon, thereby gently drying it.

[0018] In the exemplary embodiment shown in **Figure 1**, the drying surface **130** comprises two surfaces, one being the surface of the worktop **110** itself, and the other being the surface of a drawer-like element **140** which is slidable in an accommodation or housing defined within an external worktop structure **143**; the drawer-like element **140** can slide between a first position, in which the drawer-like element **140**, and thus its drying surface, is contained, *i.e.* fully inserted within the external worktop structure **143** (just a handgrip portion **145** provided on the front of the drawer-like element **140** protruding from the worktop **110** for enabling the extraction of the drawer-like element **140**), and a second position (the one depicted in **Figure 1**) in which the drawer-like element **140**, and thus its drying surface, is extracted and extended horizontally out of the external worktop structure. This arrangement provides a quite large drying surface for lying even relative large garments in stretched condition; in alternative embodiments of the invention, the drying surface may consist of the surface of the drawer-like element **140** only, the surface of the worktop **110** not being

provided with apertures, or the drawer-like element **140** may be absent, the drying surface being in such a case formed by the top surface of the worktop **110**. However, providing the drawer-like element **140** enables garments to be dried even when the surface of the worktop **110** is not directly accessible, due to obstacles immediately above the worktop.

[0019] Both the worktop **110** and the drawer-like element **140** are internally hollow so as to integrally form an air passage for conveying the flow of drying air under and along the drying surface **130**. The air passage defines a drying-medium conveying channel fluidly connected with air circulating means. The air circulating means may for instance comprise at least one blower arranged inside the appliance cabinet and adapted to take in air from either the interior or the exterior of the cabinet **105** to convey it into the drying-medium conveying channel. The blower may be housed within a proper accommodation provided to this purpose inside the cabinet of the appliance, or inside the worktop external structure **143**, in order to take in the ambient air from the interior of the cabinet (which is normally not air-tight and thus is in fluid communication with the external ambient, from which air can enter into the cabinet). Other arrangements are however possible, as described in EP 1845185, which is incorporated herein by reference; in particular, and merely by way of example, the air circulating means may be located outside the cabinet **105**, for example being associated to the upper backward portion of the cabinet **105** in proximity to and below the worktop **110** projecting from the casing, or be arranged above the worktop **110**. The air to be conveyed to the drying surface may be ambient air taken in from the exterior or interior of the cabinet, or, in case the household appliance is a dryer or a washer dryer, particularly of the type having a condenser to remove moisture from the process air used to dry the items in the drum, the air to be conveyed to the drying surface can be process air used to dry the items inside the dryer drum, or air used to cool the condenser.

[0020] **Figure 2** shows in detail and in exploded view the structure of the worktop **110**, in an embodiment of the present invention. The worktop **110** is also shown in cross-section in **Figure 3A**.

[0021] The worktop **110** comprises an outer frame **205**, for example in plastic material, shaped and sized so as to be adapted to be mounted on top of the cabinet **105**. The outer frame **205** has an inner perimetral edge **207** defining an abutment support surface for a perforated metal plate **210** that forms the top surface of the worktop **110**. The outer frame **205** is mounted to a lower base **213**, having, on the rear part thereof, a concave or downwardly inclined portion **255** or in general a shape adapted to cause water deposits to converge towards a water drainage hole **260**; the remaining part **257** of the lower base **213** is preferably slightly inclined towards the concave portion **255**. The drawer-like element **140** is comprised of another perforated metal plate **215** with downwardly bent edges **220**, through which the metal plate

215 is mounted to a drawer base **225** in a spaced-apart way so as to define an air passage for the drying air. The drawer base **225**, at opposite sides thereof, is shaped so as to define two elongated seats **230** adapted to accommodate respective sliders **233** which are slidable within and along sliding guides **235** mounted to the base **213**. Preferably, also the drawer base **225** is shaped (for example, inclined) such that any water deposit converges and fall onto the lower based **213**. A front member **240** is mounted frontally to the perforated metal plate **215** and defines a handgrip for facilitating the extraction of the drawer-like element **140** from the worktop **110**.

[0022] A blower **245** and a resistance heater **250** are accommodated between the outer frame **205** and the lower base **213** in the back thereof. In the back of the outer frame **205**, in correspondence of the blower **245**, an aperture **253** is provided for the intake of air to be conveyed through the apertures in the drying surface.

[0023] The drying surface **130** is thus comprised of the perforated metal plate **210** and the perforated metal plate **215**. Thanks to the fact that the perforated plates **210** and **215** are in metal, which is a heat conductor, the heat generated by the resistance heater **250** heats the drying surface, promoting the drying of the garments laid thereon.

[0024] The inclination of the lower base **213** and its concave portion **255** facilitate convergence towards the drainage hole **260** of water deposits possibly caused by dripping of water through the apertures **135** in the drying surface **130**, due for example to the fact that excessively wet garments are laid on the drying surface **130**. As will be described in the following, the drainage hole is fluidly connected to a drainage conduit for draining the water deposits.

[0025] **Figure 3** schematically depicts a portion of one or both of the perforated metal plates **210** and **215**, in a preferred invention embodiment. In regions between the apertures **135**, the metal plates **210** and **215** are shaped so as to define bumps **305** projecting upwardly, so that when garments are laid on the drying surface **130**, they remain distanced from the apertures **135**, and thus facilitate the flow of drying air out of the apertures **135** themselves.

[0026] **Figures 4** and **5** schematically show exemplary arrangements for draining water deposits from the worktop **110**, suitable to be implemented in a washer or washer dryer.

[0027] In particular, **Figure 4** shows an arrangement according to an embodiment of the present invention in which a drainage conduit **405** (part of which is also visible in **Figure 3A**, being denoted **305**) is provided within the cabinet **105** fluidly connecting the drainage hole **260** provided in the lower base of the worktop **110** to a water discharge pump **410** of the washer or washer/dryer, typically provided for discharging the washing liquid from the tub that rotatably accommodates the drum to a water drainage (through a discharge hose **415**). In this way, when the pump **410** is activated to discharge the washing

liquid from the drum, also the water deposit in the worktop **110** is discharged.

[0028] **Figure 5** shows another arrangement according to an embodiment of the present invention, in which the drainage conduit **505** leads from the drainage hole **260** to an externally accessible location in the cabinet **105**, for example in the region where a washing liquid filter is accommodated; this region is typically accessible to the user, for instance by opening a portlet **510**, for regular inspection and cleaning of the filter **505**. The drainage conduit **405** may for example end in correspondence of this region, and be closed at its free end by a cap, which the user can open to discharge the water deposit possibly present in the worktop.

[0029] In the following, other solutions according to different embodiments of the invention will be described adapted to drain water deposits from the household worktop **110**.

[0030] Referring to **Figures 6** and **7**, a solution according to an embodiment of the present invention for draining water deposits from the worktop **110** which is particularly adapted to a dryer is shown. As known in the art, a condenser-type dryer typically comprises a closed-loop drying air circuit, adapted to cause heated drying air to circulate through the dryer drum **605**, an air-cooled condenser **610**, *i.e.* an air/air heat exchanger, adapted to remove moisture from the hot moisture-laden drying air exiting the drum **605**, and an open-loop cooling air circuit adapted to circulate through the air-cooled condenser a stream of cooling air taken in from the outside ambient to cool said condenser, and to let out said stream of cooling air again into the outside ambient.

[0031] Through the closed-loop drying air circuit, the hot and moisture-laden drying air is caused to leave the drum **605** and is conveyed towards the air-cooled condenser **610**; then, the dehydrated drying air exiting the condenser is sent back into the drum, upon having been duly heated up again, so as to remove additional moisture from the clothes being tumbled in the drum. Heating means are provided downstream from the air-cooled condenser to heat up the dehydrated drying air due to be sent again into the drum.

[0032] The air-cooled condenser comprises a plurality of fluid passageways, along which the clothes drying air is able to flow for having the moisture condensed and removed therefrom, and these fluid passageways are exposed to the flow of cooling air flowing in the open-loop cooling air circuit. When the cooling air passes through the condenser, the drying air temperature is lowered and heated is transferred to the cooling air; thus, the cooling air which is released into the ambient is warm.

[0033] The condenser **610** is typically arranged at the base of the appliance, under the drum **605**. In order to collect condense water dripping from the condenser, a water condense collecting tray **615** is placed below the condenser **610**. The condense water collected in the tray is conveyed, through a pump **620** and a pipe **625**, to a main tank **630**, which is removably accommodated in the

machine cabinet, for example in an upper region thereof, so as to be easily extracted by a user for emptying. The main tank **630** is preferably slidably accommodated within a tank container or hopper **631** shaped in such a way as to collect water possibly overflowing from the tank **630** through an overflow opening **632**, and connected through a pipe **633** to the water condense collecting tray **615**.

[0034] The dryer may also be equipped with a steam generator **635**, for example an electric boiler, supplied through a pipe **637** with water stored in a secondary tank **640**; in operation, the steam generator **635** generates steam by evaporating the water taken from the secondary tank **640**, located for example aside the main tank **630**, and the generated steam is conveyed, through a steam delivery conduit **645**, into the inner region of the drum **605** for treating the laundry being dried. The secondary tank **640** may also be in fluid communication with the main tank **630**, so that the condense water may be exploited for generating steam.

[0035] According to an embodiment of the present invention, shown in **Figure 7**, the main tank **630** into which the condense water is pumped is provided with an upper opening **705** which, when the main tank **630** is inserted into the cabinet, is located below the drainage hole **260** provided in the worktop **110**; the opening **705** may for example be the overflow opening **632**. Preferably, a short conduit **710** is attached to the worktop below the drainage hole **160** to convey the water deposit from the worktop to the main tank **630**.

[0036] In alternative embodiments of the present invention, the water deposit in the worktop **110** may be discharged into the main tank container or hopper **631**, and from there conveyed to the water condense collecting tray **615**.

[0037] In still alternative embodiments of the present invention, the drainage hole **260** in the worktop may be fluidly connected directly to the water condense collecting tray **615**, by means of a pipe, or to the secondary tank **640**.

[0038] The present invention has been here described by presenting some exemplary embodiments thereof. Several changes to the described embodiments, as well as different embodiments of the present invention are possible, without departing from the scope of the appended claims.

[0039] For example, the embodiments described in connection with **Figures 6** and **7** may be implemented as well in a heat-pump dryer, instead of an air condenser dryer.

[0040] A solution similar to that of **Figures 6** and **7** may be implemented in a dryer of the type described in the co-pending European patent application No. 08157219, in the name of the present Applicant, which is incorporated herein by reference, wherein the main tank **630** takes the form of a reservoir being fitted removably to, and projecting from, an inner wall of the door **125** of the appliance. The drainage hole **260** may be fluidly connected, by means of a pipe, to an inlet opening of the reservoir,

so that any water deposit in the worktop is discharged into the reservoir.

5 Claims

1. A household appliance (**100**) comprising a cabinet (**105**) provided with a worktop (**110**) defining a surface (**130**) having a plurality of apertures (**135**) in fluid communication with an air conveying system (**245**) adapted to deliver a flow of air through said apertures,
characterized by comprising
a liquid drainage arrangement (**255,260,405,410,705,710**) adapted to drain liquid deposits from said worktop.
2. The household appliance of claim 1, wherein said liquid drainage arrangement comprises a liquid drainage hole (**260**) provided in the worktop.
3. The household appliance of claim 2, wherein said worktop comprises a base (**213**) shaped so as to cause liquid deposits to converge towards the liquid drainage hole.
4. The household appliance of claim 2 or 3, wherein said liquid drainage hole is fluidly connected to a washing liquid discharge pump (**410**) of the household appliance provided for discharging washing liquid from a tub of the household appliance.
5. The household appliance of claim 2 or 3, wherein a liquid drainage conduit (**505**) is connected at one end thereof to the liquid drainage hole, and, at another end, the liquid drainage conduit terminates at a user-accessible location (**510**) of said cabinet.
6. The household appliance of claim 2 or 3, wherein said liquid drainage hole is fluidly connected to a condense liquid collection arrangement (**615,630**) provided in the household appliance for collecting condense liquid from a condenser (**610**) of a laundry drying circuit.
7. The household appliance of claim 6, wherein said liquid collection arrangement comprises a condense liquid collection tank (**630**) fluidly connected to a condense liquid collection tray (**615**) below the condenser.
8. The household appliance of claim 7, wherein the liquid drainage hole is fluidly connected to the liquid collection tank.
9. The household appliance of claim 8, wherein said liquid drainage hole is located above an opening in the liquid collection tank so that liquid deposits may

fall through the liquid drainage and said opening hole into the liquid collection tank.

10. The household appliance of claim 7, wherein the liquid collection tank is accommodated within a tank container **(631)** fluidly connected to the liquid collection tray, in such a way that liquid overflowing from the liquid connection tank is discharged into the liquid collection tray, and wherein the liquid drainage hole is fluidly connected to the tank container. 5 10
11. The household appliance of claim 7, wherein the liquid drainage hole is fluidly connected to the condense liquid collection tray. 15
12. The household appliance of claim 2, comprising a steam generation arrangement **(635,640)** including a steam generator **(635)** and a steam generator water tank **(640)**, and wherein the liquid drainage hole is fluidly connected to the steam generator water tank. 20
13. The household appliance of any one of the preceding claims, wherein said surface is in metal. 25
14. The household appliance according to any one of the preceding claims, wherein said surface has upward protrusions **(305)** between said apertures so as to keep garments laid on said surface distanced from said apertures. 30

35

40

45

50

55

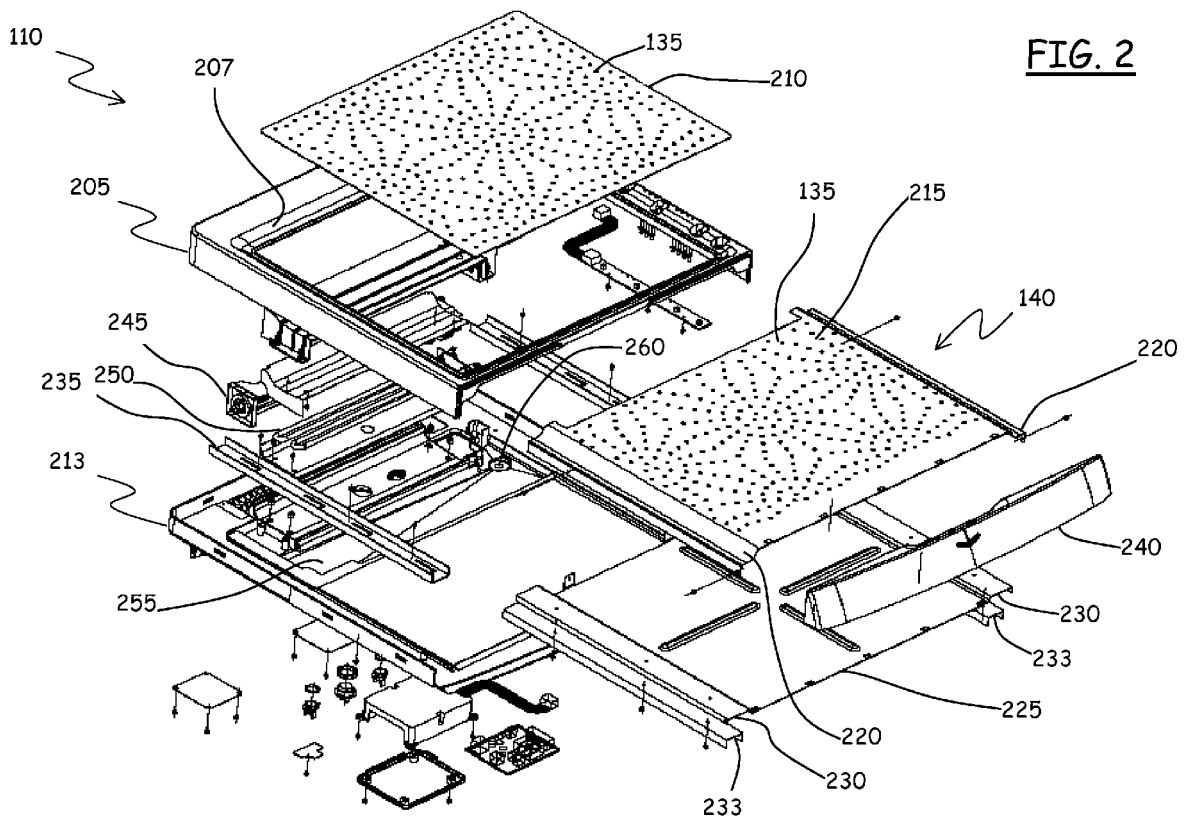

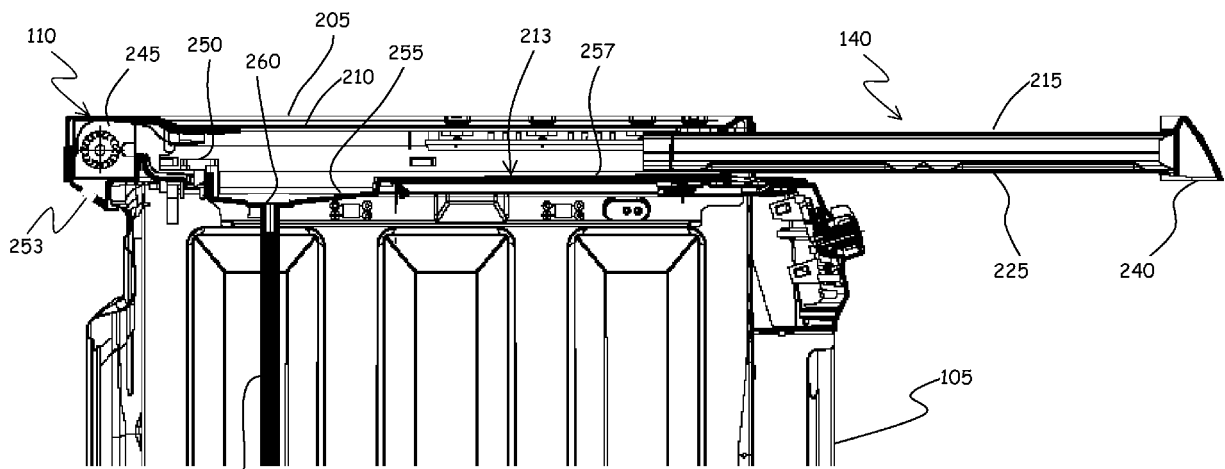

FIG. 3A

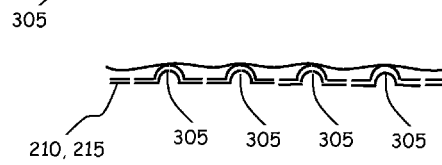

FIG. 3B

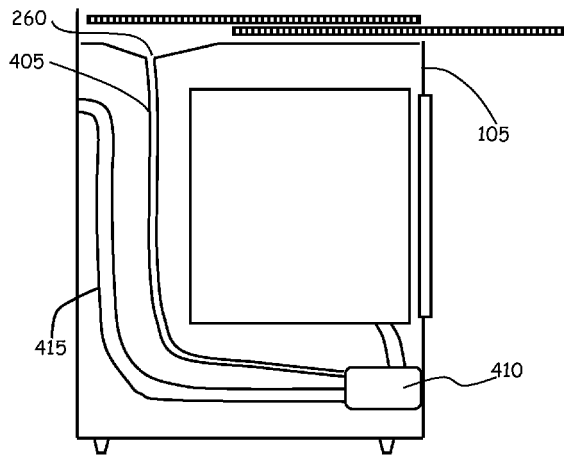

FIG. 4

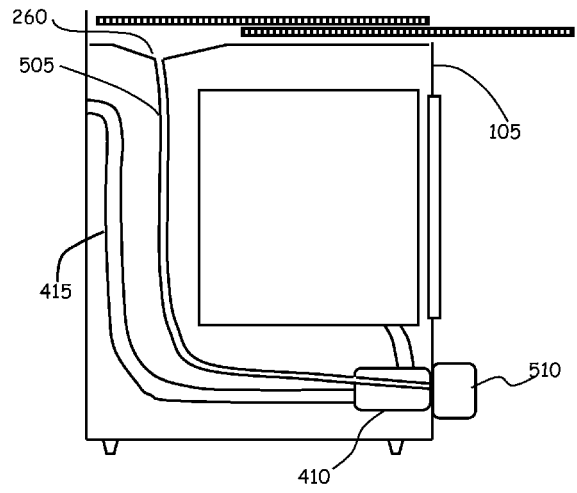

FIG. 5

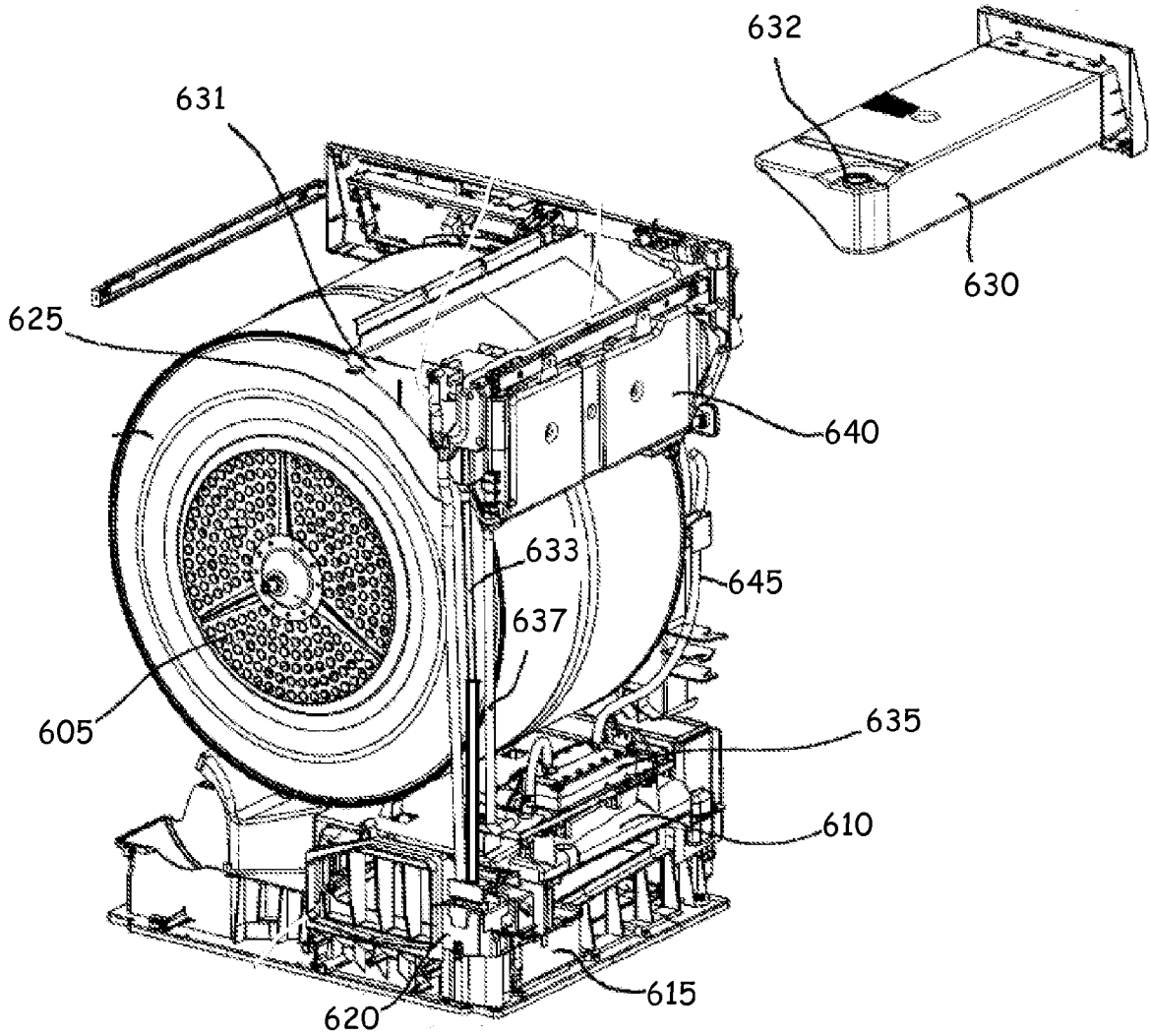

FIG. 6

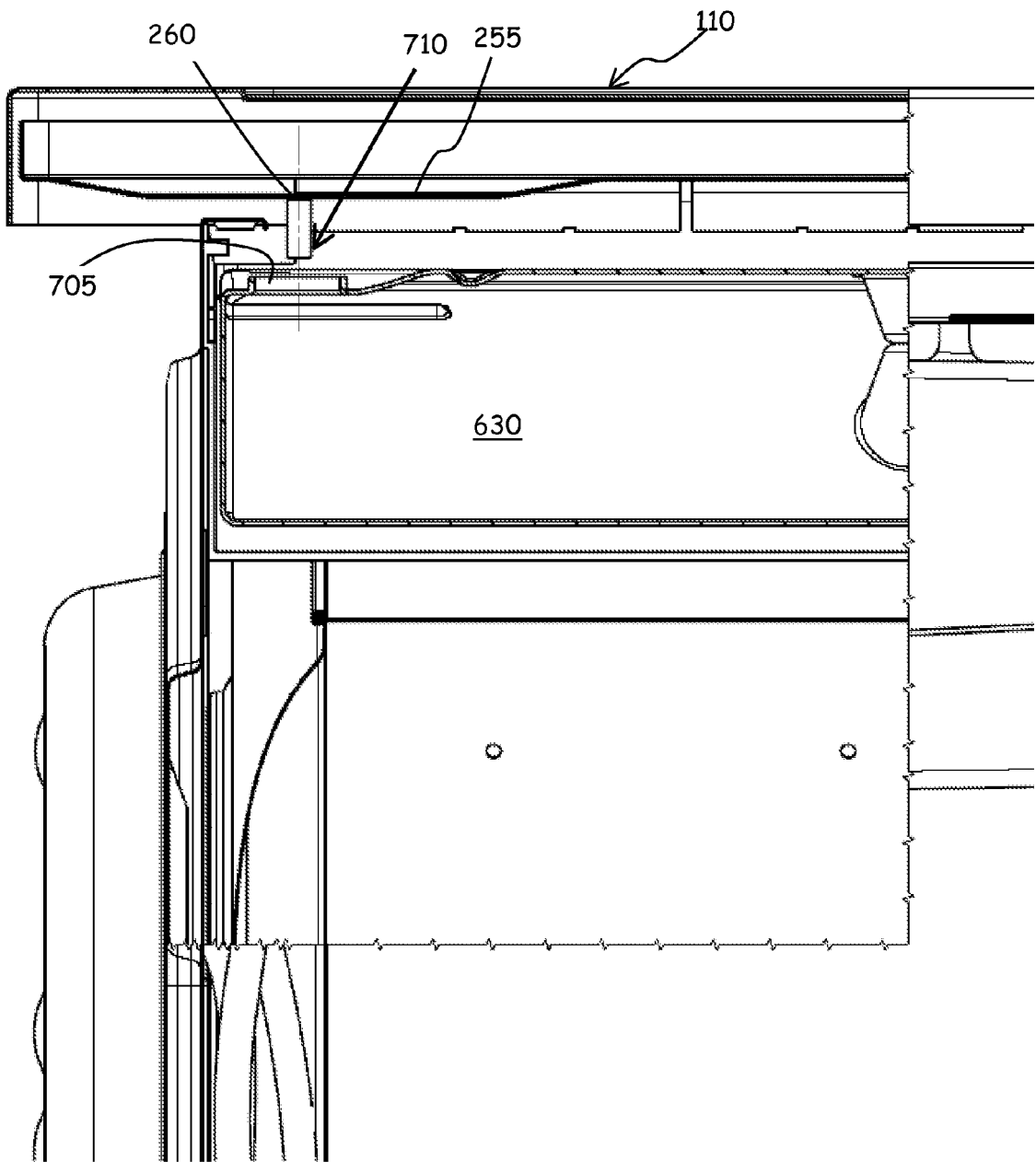

FIG. 7



EUROPEAN SEARCH REPORT

Application Number
EP 08 17 1991

DOCUMENTS CONSIDERED TO BE RELEVANT			
Category	Citation of document with indication, where appropriate, of relevant passages	Relevant to claim	CLASSIFICATION OF THE APPLICATION (IPC)
A,D	EP 1 845 185 A (ELECTROLUX HOME PROD CORP [BE]) 17 October 2007 (2007-10-17) * figures 1,2 *	1-14	INV. D06F58/16 D06F58/20
A,D	EP 1 854 916 A (ELECTROLUX HOME PROD CORP [BE]) 14 November 2007 (2007-11-14) * figures 12-14 *	1-14	
A	EP 1 431 442 A (BSH BOSCH SIEMENS HAUSGERAETE [DE]) 23 June 2004 (2004-06-23) * column 5, paragraph 26 - paragraph 28; figures 1,2 *	1-14	
A	US 2007/151120 A1 (TOMASI DONALD M [US] ET AL) 5 July 2007 (2007-07-05) * the whole document *	1-14	
A	FR 2 289 658 A (BOSCH SIEMENS HAUSGERAETE [DE]) 28 May 1976 (1976-05-28) * figure 1 *	1-14	
A	EP 1 029 961 A (IAR SILTAL S P A [IT]) 23 August 2000 (2000-08-23) * abstract; figure 1 *	1-14	TECHNICAL FIELDS SEARCHED (IPC) D06F
The present search report has been drawn up for all claims			
Place of search Munich		Date of completion of the search 20 May 2009	Examiner Lodato, Alessandra
CATEGORY OF CITED DOCUMENTS X : particularly relevant if taken alone Y : particularly relevant if combined with another document of the same category A : technological background O : non-written disclosure P : intermediate document		T : theory or principle underlying the invention E : earlier patent document, but published on, or after the filing date D : document cited in the application L : document cited for other reasons & : member of the same patent family, corresponding document	

3
EPO FORM 1503 03.82 (F04C01)

**ANNEX TO THE EUROPEAN SEARCH REPORT
ON EUROPEAN PATENT APPLICATION NO.**

EP 08 17 1991

This annex lists the patent family members relating to the patent documents cited in the above-mentioned European search report. The members are as contained in the European Patent Office EDP file on
The European Patent Office is in no way liable for these particulars which are merely given for the purpose of information.

20-05-2009

Patent document cited in search report		Publication date	Patent family member(s)	Publication date
EP 1845185	A	17-10-2007	WO 2007118551 A1	25-10-2007
			KR 20080113439 A	30-12-2008

EP 1854916	A	14-11-2007	WO 2007128358 A1	15-11-2007

EP 1431442	A	23-06-2004	DE 10259346 A1	08-07-2004

US 2007151120	A1	05-07-2007	NONE	

FR 2289658	A	28-05-1976	DE 2451339 A1	29-04-1976
			ES 440971 A1	01-03-1977
			GB 1510528 A	10-05-1978
			IT 1043600 B	29-02-1980

EP 1029961	A	23-08-2000	AT 289637 T	15-03-2005
			DE 69923830 D1	31-03-2005
			DE 69923830 T2	29-12-2005
			ES 2239425 T3	16-09-2005
			IT MI990304 A1	16-08-2000
			PT 1029961 E	31-05-2005
			TR 9903165 A2	21-09-2000

REFERENCES CITED IN THE DESCRIPTION

This list of references cited by the applicant is for the reader's convenience only. It does not form part of the European patent document. Even though great care has been taken in compiling the references, errors or omissions cannot be excluded and the EPO disclaims all liability in this regard.

Patent documents cited in the description

- EP 1845185 A [0003] [0004] [0016] [0019]
- EP 1854916 A [0003] [0004] [0016]
- EP 08157219 A [0040]