



US 20120163960A1

(19) **United States**

(12) **Patent Application Publication**

Ress, JR. et al.

(10) **Pub. No.: US 2012/0163960 A1**

(43) **Pub. Date: Jun. 28, 2012**

(54) **GAS TURBINE ENGINE AND VARIABLE CAMBER VANE SYSTEM**

Publication Classification

(51) **Int. Cl.**
F01D 9/02 (2006.01)
F01D 25/24 (2006.01)
F01D 5/20 (2006.01)

(52) **U.S. Cl.** **415/173.1; 415/208.1**

(57) **ABSTRACT**

One embodiment of the present invention is a unique variable camber vane system for a gas turbine engine. Another embodiment is a unique gas turbine engine. Other embodiments include apparatuses, systems, devices, hardware, methods, and combinations for gas turbine engines and variable camber vane systems. Further embodiments, forms, features, aspects, benefits, and advantages of the present application will become apparent from the description and figures provided herewith.

(76) Inventors: **Robert A. Ress, JR.**, Carmel, IN (US); **James Morton**, Greenwood, IN (US); **Dan Molnar**, Lebanon, IN (US)

(21) Appl. No.: **12/978,843**

(22) Filed: **Dec. 27, 2010**

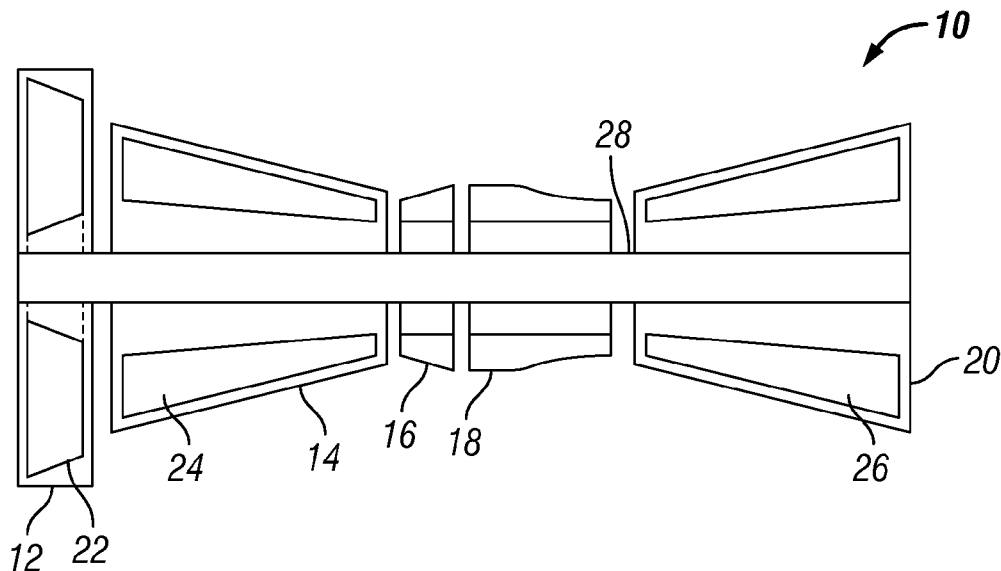

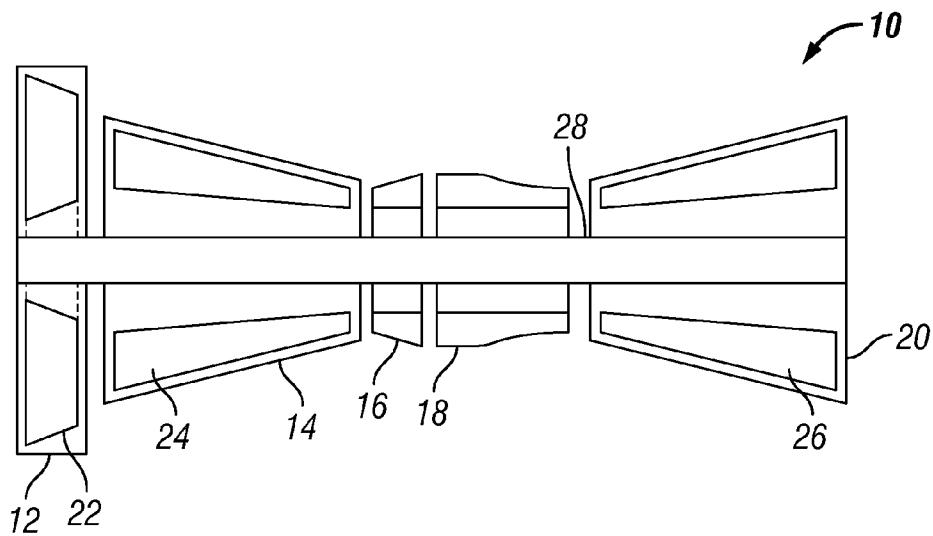

FIG. 1

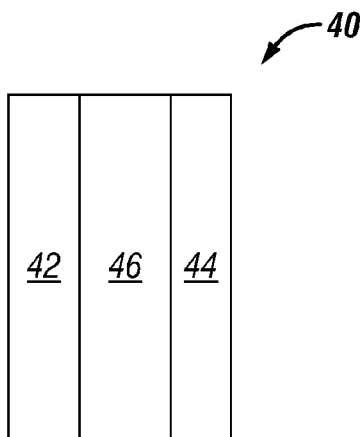

FIG. 2

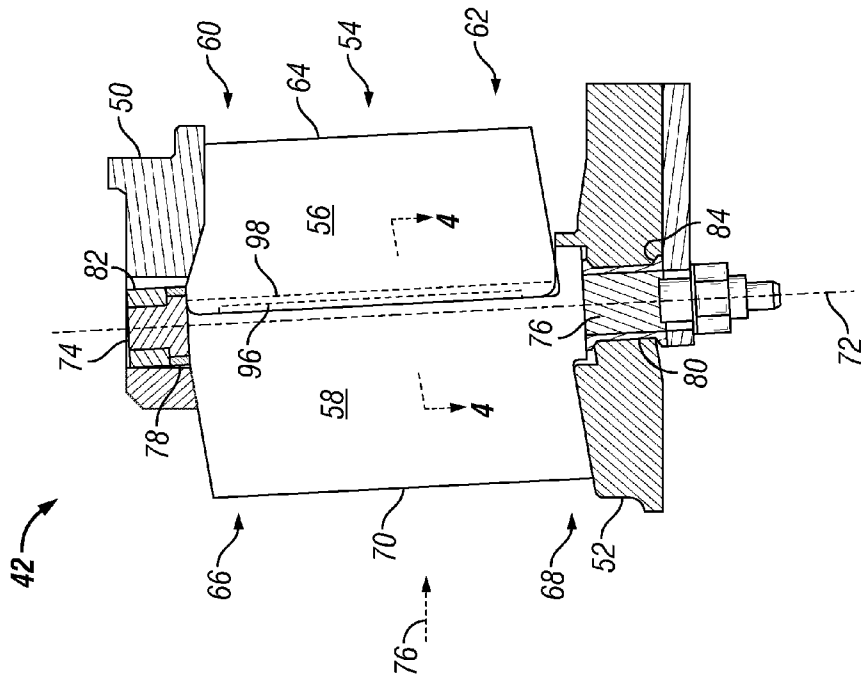

FIG. 3

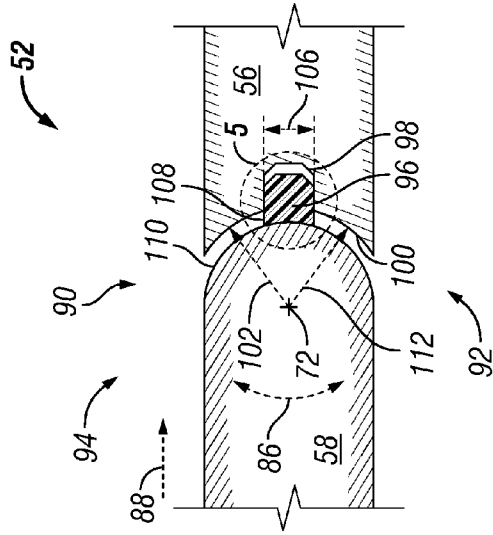

FIG. 4

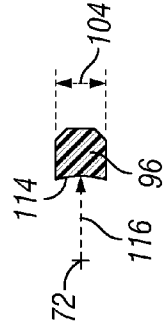

FIG. 5

GAS TURBINE ENGINE AND VARIABLE CAMBER VANE SYSTEM

GOVERNMENT RIGHTS

[0001] The present application was made with the United States government support under Contract No. FA8650-07-C-2803, awarded by the United States Air Force. The United States government may have certain rights in the present application.

FIELD OF THE INVENTION

[0002] The present invention relates to gas turbine engines, and more particularly, to gas turbine engines with variable camber vane systems.

BACKGROUND

[0003] Gas turbine engines with variable camber vane systems remain an area of interest. Some existing systems have various shortcomings, drawbacks, and disadvantages relative to certain applications. Accordingly, there remains a need for further contributions in this area of technology.

SUMMARY

[0004] One embodiment of the present invention is a unique variable camber vane system for a gas turbine engine. Another embodiment is a unique gas turbine engine. Other embodiments include apparatuses, systems, devices, hardware, methods, and combinations for gas turbine engines and variable camber vane systems. Further embodiments, forms, features, aspects, benefits, and advantages of the present application will become apparent from the description and figures provided herewith.

BRIEF DESCRIPTION OF THE DRAWINGS

[0005] The description herein makes reference to the accompanying drawings wherein like reference numerals refer to like parts throughout the several views, and wherein:

[0006] FIG. 1 schematically depicts some aspects of a non-limiting example of a gas turbine engine in accordance with an embodiment of the present invention.

[0007] FIG. 2 schematically depicts some aspects of a non-limiting example of a fan system for a gas turbine engine in accordance with an embodiment of the present invention.

[0008] FIG. 3 depicts some aspects of a non-limiting example of a variable camber guide vane system in accordance with an embodiment of the present invention.

[0009] FIG. 4 depicts some aspects of the variable camber guide vane system of FIG. 3.

[0010] FIG. 5 depicts some aspects of a non-limiting example of a seal strip in accordance with an embodiment of the present invention.

DETAILED DESCRIPTION

[0011] For purposes of promoting an understanding of the principles of the invention, reference will now be made to the embodiments illustrated in the drawings, and specific language will be used to describe the same. It will nonetheless be understood that no limitation of the scope of the invention is intended by the illustration and description of certain embodiments of the invention. In addition, any alterations and/or modifications of the illustrated and/or described embodiment (s) are contemplated as being within the scope of the present

invention. Further, any other applications of the principles of the invention, as illustrated and/or described herein, as would normally occur to one skilled in the art to which the invention pertains, are contemplated as being within the scope of the present invention.

[0012] Referring to the drawings, and in particular FIG. 1, a non-limiting example of a gas turbine engine 10 in accordance with an embodiment of the present invention is depicted. In one form, gas turbine engine 10 is an aircraft propulsion power plant. In other embodiments, gas turbine engine 10 may be a land-based or marine engine. In one form, gas turbine engine 10 is a multi-spool turbofan engine. In other embodiments, gas turbine engine 10 may be a single or multi-spool turbofan, turboshaft, turbojet, turboprop gas turbine or combined cycle engine.

[0013] Gas turbine engine 10 includes a fan system 12, a compressor system 14, a diffuser 16, a combustion system 18 and a turbine system 20. Compressor system 14 is in fluid communication with fan system 12. Diffuser 16 is in fluid communication with compressor system 14. Combustion system 18 is fluidly disposed between compressor system 14 and turbine system 20. Fan system 12 includes a fan rotor system 22. In various embodiments, fan rotor system 22 includes one or more rotors (not shown) that are powered by turbine system 20. Compressor system 14 includes a compressor rotor system 24. In various embodiments, compressor rotor system 24 includes one or more rotors (not shown) that are powered by turbine system 20. Turbine system 20 includes a turbine rotor system 26. In various embodiments, turbine rotor system 26 includes one or more rotors (not shown) operative to drive fan rotor system 22 and compressor rotor system 24. Turbine rotor system 26 is driving coupled to compressor rotor system 24 and fan rotor system 22 via a shafting system 28. In various embodiments, shafting system 28 includes a plurality of shafts that may rotate at the same or different speeds and directions. In some embodiments, only a single shaft may be employed.

[0014] During the operation of gas turbine engine 10, air is drawn into the inlet of fan 12 and pressurized by fan 12. Some of the air pressurized by fan 12 is directed into compressor system 14, and the balance is directed into a bypass duct (not shown). Compressor system 14 further pressurizes the air received from fan 12, which is then discharged into diffuser 16. Diffuser 16 reduces the velocity of the pressurized air, and directs the diffused airflow into combustion system 18. Fuel is mixed with the pressurized air in combustion system 18, which is then combusted. In one form, combustion system 18 includes a combustion liner (not shown) that contains a continuous combustion process. In other embodiments, combustion system 18 may take other forms, and may be, for example, a wave rotor combustion system, a rotary valve combustion system, or a slinger combustion system, and may employ deflagration and/or detonation combustion processes. The hot gases exiting combustor 18 are directed into turbine system 20, which extracts energy in the form of mechanical shaft power to drive fan system 12 and compressor system 14 via shafting system 28. The hot gases exiting turbine system 20 are directed into a nozzle (not shown), and provide a component of the thrust output by gas turbine engine 10.

[0015] Referring to FIG. 2, a non-limiting example of some aspects of fan system 12 in accordance with an embodiment of the present invention is schematically depicted. Fan system 12 includes a variable guide vane system 40 having a variable

inlet guide vane stage 42 and a variable outlet guide vane stage 44 disposed on either side of a rotating fan stage 46. Variable inlet guide vane stage 42 is operative to guide air into rotating fan stage 46, and to selectively vary the incidence angle of the air flow entering rotating fan stage 46. Variable outlet guide vane stage 44 is operative to guide air exiting rotating fan stage 46, and to selectively vary the incidence angle of the air flow exiting rotating fan stage 46. Variable inlet guide vane stage 42 and variable outlet guide vane stage 44 are actuated by an actuation system (not shown). Although described herein as with respect to fan system 12, it will be understood that variable guide vane system 40 may also or alternatively be employed as part of compressor system 14. In addition, although variable guide vane system 40 includes both variable inlet and outlet guide vane stages, other embodiments may include only a variable inlet guide vane stage or a variable outlet guide vane stage.

[0016] Referring to FIGS. 3-5, a non-limiting example of some aspects of variable inlet guide vane stage 42 in accordance with an embodiment of the present invention is illustrated. It will be understood that some embodiments of variable outlet guide vane stage 44 may be similar to variable inlet guide vane stage 42, and hence, the following description of variable inlet guide vane stage 42 is also applicable to aspects of some embodiments of variable outlet guide vane stage 44. Variable inlet guide vane stage 42 includes an outer band 50, an inner band 52 and plurality of vanes 54. Outer band 50 defines an outer flowpath wall of variable inlet guide vane stage 42. Inner band 52 defines an inner flowpath wall of variable inlet guide vane stage 42. Vanes 54 are airfoils that extend between outer band 50 and inner band 52, and are spaced apart circumferentially. In one form, vanes 54 extend in the radial direction between outer band 50 and inner band 52. In other embodiments, vanes 54 may extend between outer band 50 and inner band 52 at other angles.

[0017] Each vane 54 includes an airfoil portion 56 and an airfoil portion 58. Airfoil portion 56 extends between a tip portion 60 and a root portion 62. In one form, airfoil portion 56 includes the trailing edge 64 of vane 54. In other embodiments, airfoil portion 56 may be formed with a leading edge of vane 54 instead of trailing edge 64, e.g., for use in variable outlet guide vane 44. Airfoil portion 58 extends between a tip portion 66 and a root portion 68. In one form, airfoil portion 58 includes the leading edge 70 of vane 54. In other embodiments, airfoil portion 58 may be formed with a trailing edge instead of leading edge 70, e.g., for use in variable outlet guide vane 44. In one form, airfoil portion 56 is fixed, i.e., stationary. In other embodiments, airfoil portion 56 may be movable, e.g., pivotable about an axis so as to be able to vary the angle of the trailing edge of vane 54. In one form, airfoil portion 58 is variable, being configured to pivot about a pivot axis 72 with respect to airfoil portion 56, to provide a variable camber for vane 54. In other embodiments, airfoil portion 58 may be fixed. In one form, airfoil portion 58 is coupled to an actuation system (not shown) that is operative to selectively position airfoil portion 58 at a desired incidence angle. In other embodiments, airfoil portion 56 may also or alternatively be coupled to an actuation system (not shown) that is operative to selectively position airfoil portion 56 at a desired incidence angle.

[0018] Extending from airfoil portion 58 are pivot shafts 74 and 76, which establish pivot axis 72. Outer band 50 includes a plurality of spaced apart openings 78. Inner band 52 includes a plurality of spaced apart openings 80. Openings 78

and 80 are operative to receive pivot shafts 74 and 76, respectively, and retain airfoil portions 58 in the engine axial, circumferential and radial direction. In one form, pivot shafts 74 and 76 retain airfoil portion 58 in outer band 50 and inner band 52 via anti-friction bushings 82 and 84. Anti-friction bushings 82 and 84 are operative to provide bearing surfaces for pivot shafts 74 and 76. Other embodiments may not include anti-friction bushings 82 and 84. Airfoil portion 58 is operative to rotate in rotation directions 86 about pivot axis 72.

[0019] During the operation of engine 10, air flows past vanes 54 in the general direction illustrated as direction 88. Vane 54 has a pressure side 90 and a suction side 92, wherein the pressure on pressure side 90 exceeds that of suction side 92. The pressure differential between pressure side 90 and suction side 92 may vary, e.g., depending upon vane 54 camber and engine operating conditions. The pressure differential between pressure side 90 and suction side 92 provides an impetus to flow from pressure side 90 to suction side 92, e.g., between airfoil portion 56 and airfoil portion 58. It is desirable to reduce or prevent leakage between airfoil portion 56 and airfoil portion 58, e.g., leakage flow from pressure side 90 to suction side 92, e.g., in order to improve fan 12 and engine 10 efficiency. Accordingly, vanes 54 include a sealing arrangement 94 operative to seal between airfoil portion 56 and airfoil portion 58. Sealing arrangement 94 includes a seal strip 96 arranged to seal against fluid flow between airfoil portion 56 and airfoil portion 58 during the operation of engine 10, and to accommodate movement of one or both of airfoil portions 56 and 58, e.g., rotation of airfoil portion 58 about pivot axis 72, while sealing against fluid flow.

[0020] In one form, seal strip 96 is a rigid structure that does not substantially deform in use or installation. In other embodiments, seal strip 96 may be a flexible structure. In one form, seal strip 96 is formed of a polymeric material, such as Vespel (commercially available from DuPont Engineering Polymers, located in Newark, Del., U.S.A.) and/or Torton polyamide-imide (commercially available from Solvay Advanced Polymers, located in Alpharetta, Ga., U.S.A.). In other embodiments, seal strip 96 may be formed of other materials. In one form, seal strip 96 is disposed in a groove 98. In one form, groove 98 is disposed in a face 100 of airfoil portion 56 that faces airfoil portion 58. In one form, seal strip 96, groove 98 and face 100 extend between tip portion 60 and root portion 62 of airfoil portion 56. In other embodiments, seal strip 96, groove 98 and/or face 100 may extend only partially between tip portion 60 and root portion 62. Face 100 is formed with a radius 102 centered on pivot axis 72. In one form, face 100 is formed integrally with airfoil portion 56. In other embodiments, face 100 may be formed separately and affixed to airfoil portion 56. In one form, seal strip 96 is partially installed in groove 98, that is, leaving a portion 108 of seal strip 96 extending beyond face 100 of airfoil portion 56. Seal strip 96 has a width 104 greater than a width 106 of groove 98, and is installed into groove 98 with an interference fit, e.g., 0.001-0.002 inch. The amount of interference may vary with the needs of the application.

[0021] Airfoil portion 58 includes a crown 110 facing face 100 of airfoil portion 56. In one form, crown 110 is formed integrally with airfoil portion 58. In other embodiments, crown 110 may be formed separately and affixed to airfoil portion 58. Crown 110 is formed with a radius 112 centered on pivot axis 72. In one form, crown 110 extends between tip portion 66 and root portion 68 of airfoil portion 58, and is

positioned opposite groove 98. In other embodiments, crown 110 may extend only partially between tip portion 66 and root portion 68. In one form, face 100 of airfoil portion 56 is concave, and is operative to receive therein crown 110 opposite groove 98 in a nested arrangement. In other embodiments, face 100 may be convex. In one form, crown 110 of airfoil portion 58 is convex, and is operative to be received into face 100 in a nested arrangement. In other embodiments, crown 110 may be convex, e.g., an inverted crown. Although the depicted embodiment includes groove 98 and seal strip 96 being located in face 100, in other embodiments, groove 98 and seal strip 96 may be located in crown 110.

[0022] Seal strip 96 includes a rubbing surface 114. In one form, rubbing surface 114 is disposed opposite radius 112 of crown 110, and is operative to contact and seal against radius 112 of crown 110 of airfoil portion 58. During movement of airfoil portion 58, e.g., when changing the camber of vane 54 by rotating airfoil portion 58 about pivot axis 72, rubbing surface 114 may rub against crown 110, e.g., until wear of seal strip 96 resulting from rotation of airfoil portion 58 reduces or eliminates contact between seal strip 96 and crown 110. In other embodiments, rubbing surface 114 may be configured to be in close proximity to crown 110, but without any rubbing contact. In still other embodiments, seal strip 96 may be installed in crown 110, and rubbing surface 114 may be configured to seal against face 100.

[0023] Rubbing surface 114 is preformed prior to installation into airfoil portion 56, e.g., machined. In one form, rubbing surface 114 is configured as a radius 116 centered about pivot axis 72, e.g., the same radius as radius 112 of crown 110. In other embodiments, radius 116 may be the same radius as radius 102 of face 100 or any other radius suitable for the application. In still other embodiments, other shapes for rubbing surface 114 may be employed. In one form, rubbing surface 114 is concave. In other embodiments, rubbing surface 114 may take other forms, and may be, for example, convex.

[0024] Embodiments of the present invention include a variable camber vane system for a gas turbine engine, comprising: a first airfoil portion having a first tip portion, a first root portion, a face extending at least partially between the first tip portion and the first root portion, and a groove in the face extending at least partially between the first tip portion and the first root portion, wherein the groove has a groove width; a second airfoil portion arranged to rotate with respect to the first airfoil portion about a pivot axis, wherein the second airfoil portion includes a second tip portion; a second root portion; and a crown extending at least partially between the second tip portion and the second root portion, wherein the crown includes a crown radius centered about the pivot axis and positioned opposite the groove; and a seal strip having a seal width greater than the groove width and a rubbing surface opposite the crown radius, wherein the seal strip is at least partially disposed in the groove with an interference fit; and wherein the seal strip is arranged to seal against fluid flow between the first airfoil portion and the second airfoil portion.

[0025] In a refinement, the seal strip is a rigid structure.

[0026] In another refinement, the rubbing surface has a rubbing surface radius the same as the crown radius.

[0027] In yet another refinement, the crown is formed integrally with the second airfoil portion.

[0028] In still another refinement, the face is formed integrally with the first airfoil portion.

[0029] In yet still another refinement, the face is concave and operative to receive the crown therein.

[0030] In a further refinement, the first airfoil portion is stationary.

[0031] In a yet further refinement, the first airfoil portion and the second airfoil portion form at least part of an inlet guide vane having a fixed leading edge and a variable trailing edge; wherein the first airfoil portion includes the leading edge; and wherein the second airfoil portion includes the trailing edge.

[0032] In a still further refinement, the first airfoil portion and the second airfoil portion form at least part of an outlet guide vane having a variable leading edge and a fixed trailing edge; wherein the first airfoil portion includes the leading edge; and wherein the second airfoil portion includes the trailing edge.

[0033] Embodiments of the present invention include a gas turbine engine, comprising: at least one of a fan and a compressor having a variable camber vane system, the variable camber vane system including: at least two airfoil portions adapted to vary a camber of the variable camber vane system, wherein a first of the airfoil portions includes a groove and a second of the airfoil portions includes a crown having a crown radius; and a seal strip at least partially disposed in the groove with an interference fit, wherein the seal strip includes a rubbing surface opposite the crown radius and operative to seal against fluid flow between the first of the airfoil portions and the second of the airfoil portions.

[0034] In a refinement, the rubbing surface contacts the crown at the crown radius.

[0035] In another refinement, the seal strip is formed of a polymer material.

[0036] In yet another refinement, the seal strip is formed of at least one of Vespel and Torlon.

[0037] In still another refinement, the at least two airfoil portions form an inlet guide vane.

[0038] In a further refinement, the at least two airfoil portions form an outlet guide vane.

[0039] Embodiments include a gas turbine engine, comprising: at least one of a fan and a compressor having a variable camber vane system, the variable camber vane system including: at least two airfoil portions adapted to vary a camber of the variable camber vane system, wherein a first of the airfoil portions includes a groove; and wherein a second of the airfoil portions includes a crown having a crown radius; and a seal strip disposed in the groove; wherein the seal strip has a rubbing surface radius preformed thereon and configured for sealing engagement with the crown.

[0040] In a refinement, the seal strip is a rigid structure formed of a polymer.

[0041] In another refinement, the crown radius is convex, and the rubbing surface radius is concave.

[0042] In yet another refinement, the seal strip is fitted in the groove with an interference fit.

[0043] In still another refinement, the crown is nested within the first of the airfoil portions opposite the groove.

[0044] While the invention has been described in connection with what is presently considered to be the most practical and preferred embodiment, it is to be understood that the invention is not to be limited to the disclosed embodiment(s), but on the contrary, is intended to cover various modifications and equivalent arrangements included within the spirit and scope of the appended claims, which scope is to be accorded the broadest interpretation so as to encompass all such modi-

fications and equivalent structures as permitted under the law. Furthermore it should be understood that while the use of the word preferable, preferably, or preferred in the description above indicates that feature so described may be more desirable, it nonetheless may not be necessary and any embodiment lacking the same may be contemplated as within the scope of the invention, that scope being defined by the claims that follow. In reading the claims it is intended that when words such as "a," "an," "at least one" and "at least a portion" are used, there is no intention to limit the claim to only one item unless specifically stated to the contrary in the claim. Further, when the language "at least a portion" and/or "a portion" is used the item may include a portion and/or the entire item unless specifically stated to the contrary.

What is claimed is:

- 1. A variable camber vane system for a gas turbine engine, comprising:
 - a first airfoil portion having a first tip portion, a first root portion, a face extending at least partially between the first tip portion and the first root portion, and a groove in the face extending at least partially between the first tip portion and the first root portion, wherein the groove has a groove width;
 - a second airfoil portion arranged to rotate with respect to the first airfoil portion about a pivot axis, wherein the second airfoil portion includes a second tip portion; a second root portion; and a crown extending at least partially between the second tip portion and the second root portion, wherein the crown includes a crown radius centered about the pivot axis and positioned opposite the groove; and
 - a seal strip having a seal width greater than the groove width and a rubbing surface opposite the crown radius, wherein the seal strip is at least partially disposed in the groove with an interference fit; and wherein the seal strip is arranged to seal against fluid flow between the first airfoil portion and the second airfoil portion.
- 2. The variable camber vane system of claim 1, wherein the seal strip is a rigid structure.
- 3. The variable camber vane system of claim 1, wherein the rubbing surface has a rubbing surface radius the same as the crown radius.
- 4. The variable camber vane system of claim 1, wherein the crown is formed integrally with the second airfoil portion.
- 5. The variable camber vane system of claim 1, wherein the face is formed integrally with the first airfoil portion.
- 6. The variable camber vane system of claim 1, wherein the face is concave and operative to receive the crown therein.
- 7. The variable camber vane system of claim 1, wherein the first airfoil portion is stationary.
- 8. The variable camber vane system of claim 7, wherein the first airfoil portion and the second airfoil portion form at least part of an inlet guide vane having a fixed leading edge and a variable trailing edge; wherein the first airfoil portion includes the leading edge; and wherein the second airfoil portion includes the trailing edge.

9. The variable camber vane system of claim 7, wherein the first airfoil portion and the second airfoil portion form at least part of an outlet guide vane having a variable leading edge and a fixed trailing edge; wherein the first airfoil portion includes the leading edge; and wherein the second airfoil portion includes the trailing edge.

10. A gas turbine engine, comprising:

at least one of a fan and a compressor having a variable camber vane system, the variable camber vane system including:

at least two airfoil portions adapted to vary a camber of the variable camber vane system, wherein a first of the airfoil portions includes a groove and a second of the airfoil portions includes a crown having a crown radius; and

a seal strip at least partially disposed in the groove with an interference fit,

wherein the seal strip includes a rubbing surface opposite the crown radius and operative to seal against fluid flow between the first of the airfoil portions and the second of the airfoil portions.

11. The gas turbine engine of claim 10, wherein the rubbing surface contacts the crown at the crown radius.

12. The gas turbine engine of claim 10, wherein the seal strip is formed of a polymer material.

13. The gas turbine engine of claim 12, wherein the seal strip is formed of at least one of Vespel and Torlon.

14. The gas turbine engine of claim 10, wherein the at least two airfoil portions form an inlet guide vane.

15. The gas turbine engine of claim 10, wherein the at least two airfoil portions form an outlet guide vane.

16. A gas turbine engine, comprising:

at least one of a fan and a compressor having a variable camber vane system, the variable camber vane system including:

at least two airfoil portions adapted to vary a camber of the variable camber vane system, wherein a first of the airfoil portions includes a groove; and wherein a second of the airfoil portions includes a crown having a crown radius; and

a seal strip disposed in the groove; wherein the seal strip has a rubbing surface radius preformed thereon and configured for sealing engagement with the crown.

17. The gas turbine engine of claim 16, wherein the seal strip is a rigid structure formed of a polymer.

18. The gas turbine engine of claim 16, wherein the crown radius is convex, and wherein the rubbing surface radius is concave.

19. The gas turbine engine of claim 16, wherein the seal strip is fitted in the groove with an interference fit.

20. The gas turbine engine of claim 16, wherein the crown is nested within the first of the airfoil portions opposite the groove.

* * * * *