

*E. J. Lawson,*

*Channelling Stone.*

*No. 110,375.*

*Patented Dec. 20. 1870*

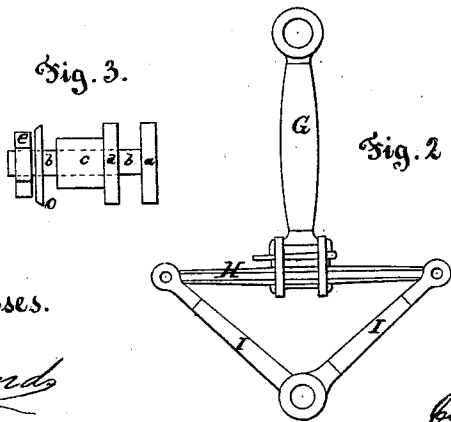
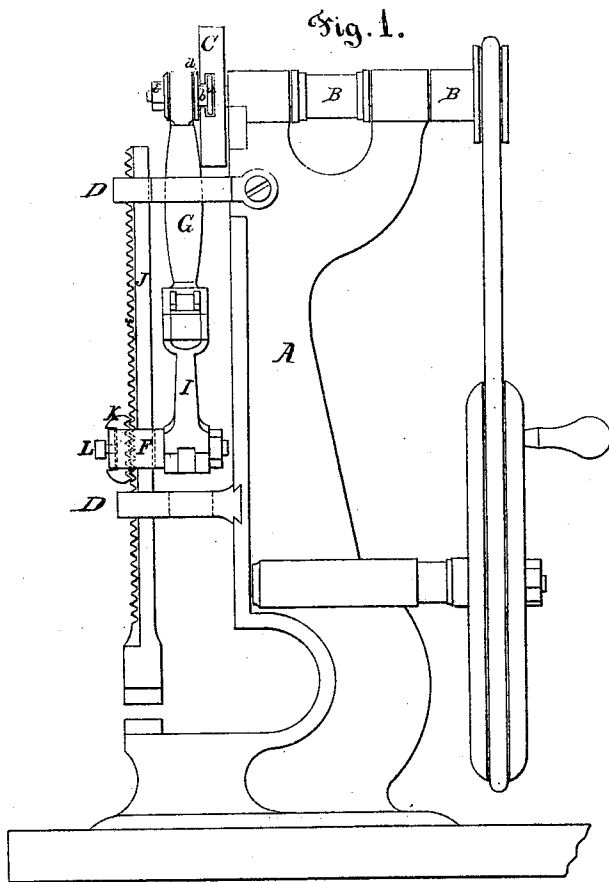

Witnesses.

*A. Freund*  
*G. Altunges*

Inventor.

*E. J. Lawson,*  
*by Dodge Munn*  
*Atty.*

# United States Patent Office.

EBENEZER G. LAMSON, OF WINDSOR, VERMONT.

Letters Patent No. 110,375, dated December 20, 1870.

## IMPROVEMENT IN STONE-DRILLING AND CHANNELING MACHINES.

The Schedule referred to in these Letters Patent and making part of the same.

To all whom it may concern:

Be it known that I, EBENEZER G. LAMSON, of Windsor, in the county of Windsor and in the State of Vermont, have invented certain new and useful Improvements in Stone-Drilling and Channeling Machine; and do hereby declare that the following is a full, clear, and exact description thereof, reference being had to the accompanying drawing and to the letters of reference marked thereon making a part of this specification.

My invention relates to improvements in machines intended for use in channeling or drilling stone; and the invention consists in a novel construction of a yielding pitman, and in the manner of clamping and adjusting the cutters or drills, and also in arranging the cutters to play in bracket-guides, in order to dispense with the cross-heads and standard-guides heretofore used in this class of machines, all as hereinafter more fully explained and described.

In the accompanying drawing—

Figure 1 represents a side elevation of a machine embodying my improvements; and

Figures 2 and 3 are views of portions represented detached, the better to illustrate their special construction.

The class of machines to which my present improvements are specially applicable is known as channeling-machines, and is used for cutting channels or grooves in the rock or beds of quarries, to assist in getting out the stone therefrom.

These machines are usually mounted on wheels, to run on a track laid on the rock; but as these features are well known, and have been fully described in my former patents, I have, in this instance, shown my improvements applied to a simple form of stationary frame, the frame, in this case, only being used to show the operation of the other parts which contain my improvements.

A represents this frame, having a shaft, B, mounted transversely in its upper end, and connected by a pulley and cord to a hand-wheel, for giving it motion.

Upon the front end of the shaft is secured a wheel, C, which has a radial slot or groove, to receive and hold an adjustable wrist-pin, the detailed construction of which is shown in fig. 3, the groove, with the pin in it, being shown in fig. 1, it being the same as shown in my patent of September 17th, 1867, and need not therefore be further described.

The yielding pitman which I have devised, and which is intended to be used as a substitute for the bow-string, shown in my former patent, consists of two arms or rods, I, hinged or pivoted together at one end, and diverging thence in the form of the letter V, at a greater or lesser angle; their opposite ends being connected by a leaf or other flat spring, H, as shown in fig. 2.

To the center of this spring, midway between the upper ends of the arms I, I secure a rod, G, the opposite end of which is provided with an eye to fit upon the wrist-pin.

In using this device one end is connected to the wrist-pin in the usual manner, while its other extremity is secured by a free joint to the clamp F, which holds or is fastened to the cutters or drill J, as shown in fig. 1. The pitman may be used either end up, but I prefer it as represented in the drawing.

It will, of course, be understood that the rod G may be made of any desired length. Where the driving-crank or wrist is near the clamp, this rod G may be only long enough to have the necessary eye for connecting it to the wrist; and where these parts are far apart, the rod G will be made proportionably longer, the main idea being to secure the function of elasticity or yielding.

It will be apparent that when the machine is set in motion the spring H, with the hinged arms I, will yield somewhat, and thus operate to produce the same beneficial results as the bow-spring hereinbefore referred to.

In this class of machines it has heretofore been customary to construct them with standard-guides, and to clamp the drills or cutters in cross-heads, which played up and down on these standard-guides.

In my present machine I have dispensed with these standard-guides and cross-heads entirely, and instead thereof, I provide the frame A with two brackets D, which project from its face, one above the other, as shown in fig. 1. In these brackets I form suitable openings, with bearings, for the cutter J to play up and down in, as represented in fig. 1.

The opening or hole in the brackets will of course be so formed as to afford a firm and steady bearing and guide for the cutter J, while the front of the hole or opening will be so formed as not to touch the teeth or serrations on the front of the cutter. If preferred, the front of the bracket may be cut away so as to be open at that point; but, if that be done, the sides will require to be made heavier in order to have the necessary rigidity and firmness.

To secure the cutter to the pitman I make a clamp, F, which consists of a strong metallic loop or block, F, having a wrist-pin or journal projecting from its rear side, on which the lower end of the pitman is secured, as shown in fig. 1. Through this block F is made a hole as long as the cutter J is wide, and of a width about double the thickness of the cutter.

I then provide a block, K, which is of the proper size to fit in this hole in front of the cutter, its rear face being serrated to correspond with the serrations on the cutter J, and with a projecting-shoulder at top and bottom to hold it in place, as represented in fig. 1.

Through the front of the clamp F I then insert

one or more set screws, L, with its inner end bearing on the block K, to press it tight against the cutter J and keep their serrations or teeth interlocked, and thus hold the cutter tight in the clamp.

When it is desired to adjust the cutter higher or lower, it is only necessary to loosen the screw L, disengage the block K from the cutter J, and then raise or lower the latter as desired, and secure it in place by tightening up the screw again. By this method of construction I dispense with the complicated devices heretofore used, and greatly lessen the weight and expense of the machine, and at the time making it simpler and easier to adjust.

Having thus described my improvements,

What I claim as of my invention is—

1. The yielding pitman, consisting of the arms I

and spring H, with the connecting-rod G or its equivalent, combined and arranged to operate substantially as described.

2. The brackets or guides D, in combination with the cutter J, arranged to play therein, substantially as set forth.

3. The clamp F, with the serrated block K and set screw L, in combination with the serrated cutter J, constructed and arranged substantially as described.

In testimony that I claim the foregoing I have hereunto set my hand this 13th day of May, 1869.

E. G. LAMSON.

Witnesses:

HENRY WARDNEE,

L. W. HAWLEY.