

(19) World Intellectual Property Organization
International Bureau



(43) International Publication Date
30 April 2009 (30.04.2009)

PCT

(10) International Publication Number
WO 2009/054762 A1

(51) International Patent Classification:
H04L 1/18 (2006.01) *H04L 1/00* (2006.01)

(21) International Application Number:
PCT/SE2007/050778

(22) International Filing Date: 25 October 2007 (25.10.2007)

(25) Filing Language: English

(26) Publication Language: English

(71) Applicant (for all designated States except US): TELEFONAKTIEBOLAGET LM ERICSSON (PUBL) [SE/SE]; S-164 83 Stockholm (SE).

(72) Inventors; and

(75) Inventors/Applicants (for US only): BJÖRKÉN, Peter [SE/SE]; Näckrosvägen 35, 4 tr, S-169 37 Solna (SE). SCHLIWA-BERTLING, Paul [DE/SE]; Hjalmar Svenfelts väg 29B, S-590 71 Ljungsbro (SE). SUNDBERG, Mårten [SE/SE]; Grindsgatan 45, S-118 57 Stockholm (SE).

(74) Agent: NILSSON, Charlotte; Ericsson AB, Patent Unit 3G, S-164 80 Stockholm (SE).

(81) Designated States (unless otherwise indicated, for every kind of national protection available): AE, AG, AL, AM, AT, AU, AZ, BA, BB, BG, BH, BR, BW, BY, BZ, CA, CH, CN, CO, CR, CU, CZ, DE, DK, DM, DO, DZ, EC, EE, EG, ES, FI, GB, GD, GE, GH, GM, GT, HN, HR, HU, ID, IL, IN, IS, JP, KE, KG, KM, KN, KP, KR, KZ, LA, LC, LK, LR, LS, LT, LU, LY, MA, MD, ME, MG, MK, MN, MW, MX, MY, MZ, NA, NG, NI, NO, NZ, OM, PG, PH, PL, PT, RO, RS, RU, SC, SD, SE, SG, SK, SL, SM, SV, SY, TJ, TM, TN, TR, TT, TZ, UA, UG, US, UZ, VC, VN, ZA, ZM, ZW.

(84) Designated States (unless otherwise indicated, for every kind of regional protection available): ARIPO (BW, GH, GM, KE, LS, MW, MZ, NA, SD, SL, SZ, TZ, UG, ZM, ZW), Eurasian (AM, AZ, BY, KG, KZ, MD, RU, TJ, TM), European (AT, BE, BG, CH, CY, CZ, DE, DK, EE, ES, FI, FR, GB, GR, HU, IE, IS, IT, LT, LU, LV, MC, MT, NL, PL, PT, RO, SE, SI, SK, TR), OAPI (BF, BJ, CF, CG, CI, CM, GA, GN, GQ, GW, ML, MR, NE, SN, TD, TG).

Declaration under Rule 4.17:

— as to applicant's entitlement to apply for and be granted a patent (Rule 4.17(ii))

Published:

— with international search report

(54) Title: METHODS AND ARRANGEMENTS IN A RADIO COMMUNICATION SYSTEM

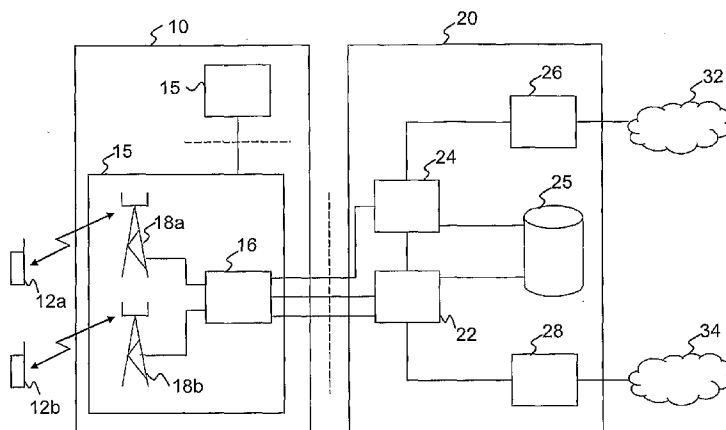

Fig. 1

(57) Abstract: The user equipment 12a and 12b comprises a radio transmitter 76 arranged to transmit data packets to the receiver 71 of the communication network entity 16 over the radio interface on the uplink channel 11 and a receiver 77 arranged to receive data packets transmitted from the transmitter 72 of the communication network entity 16 on the downlink channel 13. The user equipment 12a and 12b further comprises means 78 for analysing said received data packets as described above and in conjunction with fig. 6. Thus, while there have been shown and described and pointed out fundamental novel features of the invention as applied to a preferred embodiment thereof, it will be understood that various omissions and substitutions and changes in the form and details of the

devices illustrated, and in their operation, may be made by those skilled in the art without departing from the spirit of the invention. For example, it is expressly intended that all combinations of those elements and/or method steps which perform substantially the same function in substantially the same way to achieve the same results are within the scope of the invention. Moreover, it should be recognised that structures and/or elements and/or method steps shown and/or described in connection with any disclosed form or embodiment of the invention may be incorporated in any other disclosed or described or suggested form or embodiment as a general matter of design choice. It is the intention, therefore, to be limited only as indicated by the scope of the claims appended hereto. Expressions such as "including", "comprising", "incorporating", "consisting of", "have", "is" used to describe and claim the present invention are intended to be construed in a nonexclusive manner, namely allowing for items, components or elements not explicitly described also to be present. Reference to the singular is also to be construed to relate to the plural and vice versa. Numerals included within parentheses in the accompanying claims are intended to assist understanding of the claims and should not be construed in any way to limit subject matter claimed by these claims.

WO 2009/054762 A1

METHODS AND ARRANGEMENTS IN A RADIO COMMUNICATION SYSTEM

TECHNICAL FIELD

The present invention relates to methods, a user equipment and a communication network entity in a communication network system and, more particular to a user equipment and a communication network entity allowing for optimizing the performance of data packet transmissions as well as methods for such optimization.

BACKGROUND

Enhanced Data rates for GSM Evolution (EDGE) is an enhancement of the General Packet Radio Service (GPRS) radio interface in GSM. Nine Modulation and Coding Schemes (MCSs) are defined in EDGE. The lowest MCSs have lower bitrates but are more robust while usage of higher MCSs enables higher bitrates and increased capacity. EDGE also supports Incremental Redundancy (IR) which is a technique for combining transmissions of the same data to increase the decoding success rate.

EDGE Evolution is currently being standardized in the Third Generation Partnership Project (3GPP) Rel-7. The work items include, amongst other things, higher order modulation, dual carrier transmission downlink, reduced latency and dual-antenna terminals. The reduced latency work item includes reduced Time Transmission Interval (TTI), fast Acknowledgement / Negative Acknowledgement (Ack/Nack) reporting and Radio Link Control (RLC) non-persistent mode. Reduced latency is vital for delay sensitive applications like Voice over Internet Protocol (VoIP), which is a system enabling voice data to be delivered using the IP.

25

Usually a conversational service, such as VoIP, will have a mouth-to-ear delay requirement in order to assert an acceptable conversation quality. In a cellular system the mouth-to-ear delay basically includes one delay in the transmitting link, from the user equipment (UE) to the Base Station Controller (BSC) uplink (UL), and one delay on the receiving link, from BSC to UE downlink (DL). VoIP usually has a pre-defined delay budget e.g. 300 ms mouth-to-ear. All packets then need to be transferred within this delay budget.

30

With reduced latency the VoIP delay budget may include and be limited to one RLC retransmission on both uplink and downlink directions, called RLC non-persistent mode. This increases the coverage of the VoIP application since IR increases the decoding success rate for a retransmission. The capacity is also increased since modulation and coding schemes, MCS, carrying larger payload may be used.

The enabling of one RLC retransmission on both DL and UL increases the coverage and capacity of the VoIP service. However, if two retransmissions could be utilized in either link then the gain would be even higher. In case where the information about the age of each Protocol Data Unit (PDU) conveying speech samples is feasible to be provided to the entity controlling the radio link at the receiving end, it could be taken advantage of as outlined above.

However, as for in case of GSM/EDGE Radio Access Network (GERAN), where the BSC/ Packet Control Unit (PCU) controlling the radio link entity at the receiving end does not know the status of the VoIP data that arrives, another approach to estimate the state/age of the VoIP data is required.

Thus, a generic solution for communication systems where the explicit information about the age of the PDUs conveying the VoIP data is not available to the radio link entities at the receiving ends that are utilizing a limited number of retransmissions over the air interface is needed.

SUMMARY

Accordingly, it is an objective with the present invention to provide an improved method in a communication network entity of optimizing the performance of data packet transmissions between two user equipments via said communication network entity over an uplink transmission link and a downlink transmission link, whereby a pre-defined transmission delay is allowed for said data packets to travel from one of said user equipments to the other of said user equipments.

According to a first aspect of the present invention this objective is achieved through a method as defined in the characterising portion of claim 1, which specifies that the performance of data packet transmissions between two user equipments is optimized by a method in which received data packets originating from said uplink transmission link is

analysed for said downlink transmission link. Based on said analysed data packets a transmission delay on said uplink transmission link is estimated and remaining transmission delay for said downlink transmission link is determined. Based on said determined remaining transmission delay an action is selected for said analysed data packets which efficiently uses available radio resources on said downlink transmission link, where after said data packets are transmitted on said downlink transmission link to a receiving user equipment.

Another objective with the present invention is to provide an improved method in a user equipment of optimizing the performance of data packet transmissions between two user equipments via said communication network entity over an uplink transmission link and a downlink transmission link, whereby a pre-defined transmission delay is allowed for said data packets to travel from one of said user equipments to the other of said user equipments.

15

According to a second aspect of the present invention this other objective is achieved through a method according to the characterising portion of claim 9, which specifies that the performance of data packet transmissions between two user equipments is optimized by a method in which data packets on said downlink transmission link is received from said communication network entity, in which communication network entity said data packets originating from said uplink transmission link have been analysed, a transmission delay on said uplink transmission link based on said analysed data packets has been estimated, a remaining transmission delay for said downlink transmission link has been determined and an action for said analysed data packets has been selected based on said determined remaining transmission delay which efficiently uses available radio resources on said downlink transmission link. Said received data packets are then analysed in said user equipment.

A further objective with the present invention is to provide an improved communication network entity of optimizing the performance of data packet transmissions between two user equipments via said communication network entity over an uplink transmission link and a downlink transmission link, whereby a pre-defined transmission delay is allowed for said data packets to travel from one of said user equipments to the other of said user equipments.

35

According to a third aspect of the present invention this further objective is achieved through a communication network entity according to the characterising portion of claim 16, which specifies that the performance of data packet transmissions between two user equipments is optimized by a communication network entity comprising means for ana-
5 lysing for said downlink transmission link received data packets originating from said uplink transmission link, means for estimating a transmission delay on said uplink transmission link based on said analysed data packets, means for determining remaining transmission delay for said downlink transmission link and means for selecting for said ana-
10 lysed data packets an action based on said determined remaining transmission delay which efficiently uses available radio resources on said downlink transmission link, where after said data packets are transmitted on said downlink transmission link to a receiving user equipment.

A still further objective with the present invention is to provide an improved user equip-
15 ment of optimizing the performance of data packet transmissions between two user equipments via said communication network entity over an uplink transmission link and a downlink transmission link, whereby a pre-defined transmission delay is allowed for said data packets to travel from one of said user equipments to the other of said user equipments.

20

According to a fourth aspect of the present invention this further objective is achieved through a user equipment according to the characterising portion of claim 24, which specifies that the performance of data packet transmissions between two user equipments is optimized by a user equipment comprising means for receiving data packets on
25 said downlink transmission link from said communication network entity, in which communication network entity said data packets originating from said uplink transmission link have been analysed, a transmission delay on said uplink transmission link based on said analysed data packets has been estimated, a remaining transmission delay for said downlink transmission link has been determined and an action for said analysed data
30 packets has been selected based on said determined remaining transmission delay which efficiently uses available radio resources on said downlink transmission link. The user equipment further comprises means for analysing said received data packets.

Further embodiments are listed in the dependent claims.

Thanks to the provision of improved methods and arrangements which estimates the remaining delay budget for transfer by analyzing the packet arrival times from one link, major improvements in coverage and capacity is achieved with a flexible delay budget and link quality control, since both links (UL & DL) will be uncorrelated, i.e. the radio link quality on one link is not correlated with the quality of the other link.

Other objects and features of the present invention will become apparent from the following detailed description considered in conjunction with the accompanying drawings. It is to be understood, however, that the drawings are designed solely for purposes of illustration and not as a definition of the limits of the invention, for which reference should be made to the appended claims. It should be further understood that the drawings are not necessarily drawn to scale and that, unless otherwise indicated, they are merely intended to conceptually illustrate the structures and procedures described herein.

15 BRIEF DESCRIPTION OF THE DRAWINGS

In the drawings, wherein like reference characters denote similar elements throughout the several views:

Figure 1 is an exemplary block diagram of a mobile communication network;

20

Figure 2 is a flow chart of a conversational service using a RLC non-persistent mode.

Figure 3 is a flowchart of a conversational service using a dynamic RLC non-persistent mode according to the invention.

25

Figure 4 is an illustration of calculated examples of the gain of the invention;

Figure 5 is a flow chart illustrating the inventive method in a communication network entity;

30

Figure 6 is a flow chart illustrating the inventive method in a user equipment;

Figure 7 is a block diagram of the inventive communication network entity and user equipments.

35

DETAILED DESCRIPTION

A block diagram of an exemplary 3GPP GSM system network is shown in figure 1. The network comprises a radio access network (RAN), which in the preferred embodiment of the present invention is a GSM/EDGE Radio Access Network (GERAN) 10 and a core network (CN) 20. The GERAN 10 and the CN 20 provide communication and control for a plurality of user equipments (UE) 12 (two are shown in fig. 1).

The GERAN architecture 10 comprises a plurality of Base Station Systems (BSS) 15 each controlled by a Base Station Controller (BSC) 16 which is connected to a set of Base Transceiver Stations (BTS) 18. The BTSs 18 comprise the antennas, RF equipment and baseband processing circuits needed to communicate with the MSs 12. The BTSs 18 are connected to the BSC 16 through the Abis-interface. The architecture 10 further comprises a Packet Control Unit (PCU), which is considered a part of the BSC 16 and using BSC internal signals may provide the signalling between the BSC and the PCU. The PCU 16 is responsible for the following MAC and RLC layer functions:

- LLC layer PDU segmentation into RLC blocks for downlink transmission;
- LLC layer PDU reassembly from RLC blocks for uplink transmissions;
- PDCH scheduling functions for the uplink and downlink data transfers;
- PDCH uplink ARQ functions, including RLC block ack / nak;
- PDCH downlink ARQ function, including buffering and retransmission of RLC blocks;
- channel access control functions, e.g. access requests and grants; and
- radio channel management functions, e.g. power control, congestion control, broadcast control information, etc.

25

The core network 20 typically comprises at least one Serving GPRS Support Node (SGSN) 22, one or more Gateway GPRS Support Node (GGSN) 28, at least one mobile switching center (MSC) 24, which may include a visitor location register (VLR) (not shown in figure 1), a Gateway MSC (GMSC) 26, and a home location register (HLR) 25. The CN 20 provides both circuit-switched and packet data communication with various external networks, typically including the Public Switched Telephone Network (PSTN) 32 and one or more packet mode communication network, such as the Internet 34. The GERAN 10 connects to the CN 20 through the A, and Gb.

According to a preferred embodiment of the present invention, the communication system is herein described as a GSM communication system. The skilled person, however, realizes that the inventive method and arrangement works very well on other packet based communications systems as well, such as a Long Term Evolution (LTE) system, the W-
5 CDMA system and the CDMA2000 system. The user equipments 12 may be mobile stations such as mobile telephones ("cellular" telephones) and laptops with mobile termination and thus can be, for example, portable, pocket, hand-held, computer-included or car-mounted mobile devices which communicate voice and/or data with the RAN.

10 The purpose of the invention is to enable optimized coverage and capacity of data packet transmission services, such as a conversational service, a video service or any delay sensitive service by a method where the packet data arrival is analyzed and where the optimum MCS selection is based on the concluded delay budget. By way of example only, VoIP is used herein as a preferred embodiment of the present invention. The skilled per-
15 son realizes, however, that the invention works very well on other services as well.

The packets arriving at the BCS/PCU 16 from the UE 12 will not include information regarding the transfer in the previous link, which would help to determine the remaining delay budget based on the required mouth-to-ear delay of the service. The solution is to ap-
20 ply an analysis of packet data arrival in the BSC/PCU 16 in order to estimate the packet delay on the previous transmission link.

If the packets are delivered in-sequence from the previous link the arrival of the packets will be burstier if the packet loss is higher in the previous transmission link (= higher de-
25 lay), whereas if the packets are arriving in a periodic manner, as originally transmitted, a smaller delay is assumed.

Below follows some examples of packet analysis possible at the receiver BSC/PCU, but also at the receiving user equipment:

- 30
- Optionally, analyzing to which service a received packet belongs to, e.g. a VoIP packet may be confirmed by means of a pre-determined QoS attribute.
 - Estimating the Packet Inter-arrival Time (PIT) by monitoring arrival of individual packets and/or by measuring number of packets arrived during a time period.
 - Determining delay budget for individual packets by analyzing data flow and using
35 PIT.

- Concluding maximum allowed retransmissions for individual data packets.
- Concluding a time-out value for individual data packet.
- Selecting appropriate MCS for optimal robustness considering number of allowed retransmissions.

5

A conversational service is often characterized by transmission of multiple data packets originating from periodic generation. Typically, speech frames are generated every 20 ms and these may be transmitted as IP packets e.g. every 20/40/60 ms having 1/2/3 frames respectively per packet. Given that VoIP packages are transmitted on an error free link in the UL, the packages will arrive with the same periodic separation for the DL transfer, thus having a large delay budget since no retransmissions are made in the UL. The worse channel quality on the UL, the more will the arrival of packages deviate from the periodic arrival. With a bursty packet arrival the delay budget is lower.

15 If an analysis is made based on the bullets above and applied to each data packet there is a substantial improvement of the conversational service.

Figure 2 shows a flowchart of a conversational service using RLC non-persistent mode with a Non-Persistent Timer (NPT) of 120 ms, i.e. the dynamic RLC non-persistent mode has not been used. No delay is assumed over the transport network (TN). In fig. 2, x^a is the correctly received packets for sequence number x and, y^b is the erroneously received packets for sequence number y . All blocks, except sequence number, SN, 1 are delivered in the example within the end-to-end delay requirement of 250 ms. An RLC non-persistent timer, NPT, of 120 ms is applied to all blocks in each direction. The NPT of SN 1 will expire on the downlink, DL, since the timer value is set irrespective of the transmission time on the UL. The expiration of NPT in the network entity for SN=1 is denoted 23 and the expiration of NPT in the user equipment for SN=1 is denoted 27. Thus, SN 1 is discarded and never delivered. In fig. 2 the Round-Trip-Time (RTT) is denoted 21 and the continuous arrows illustrate a transfer time on UL/DL. The broken arrows reflect the TN.

30

Figure 3 shows a flowchart of a conversational service (only one direction shown) using dynamic RLC non-persistent mode with a NPT of 120 ms on the UL and dynamic NPT on the DL, i.e. the dynamic RLC non-persistent mode has been used. No delay is assumed over the transport network. In fig. 3, x^a is the correctly received packets for sequence number x and, y^b is the erroneously received packets for sequence number y . All blocks are delivered in the example of fig. 3 within the end-to-end delay requirement of 250 ms. Compared to the previous example, shown in fig. 2, the transmitter on the DL will analyze

the arrival time of the packets from the UL. Since 0 and 1 arrives with an expected packet inter arrival time, PIT, it is assumed that the transmission on the previous link was successful without any retransmissions, thus an NPT of approx 200 ms could be set to these SNs. Since SN 1 needs 180 ms to be delivered on the DL, this saves the block from not
 5 being delivered. The expiration of NPT in the network entity for SN=1 is denoted 23 and the expiration of NPT in the user equipment for SN=1 is denoted 27. In fig. 3 the Round-Trip-Time (RTT) is denoted 21 and the continuous arrows illustrate a transfer time on UL/DL. The broken arrows reflect the TN.

10 Calculated example:

To estimate the gain of the invention, a simple calculation can be made. In the following it is assumed that the end-to-end delay budget allows for, in total (over both links), two retransmissions. It is assumed that 1000 blocks are transmitted from the uplink transmitter. The example is illustrated in fig. 4, in which transmitted packets on the uplink are denoted
 15 41, received packets after the first attempt are denoted 42, received packets after the second attempt are denoted 43 and received packets after the third attempt are denoted 44. Discarded/erroneous packets are denoted 45. The example on the left side of fig. 4 is without the dynamic RLC non-persistent mode, wherein 46 illustrate received packets and 47 lost packets. The example on the right side of fig. 4 is with the dynamic RLC non-persistent mode, wherein 48 illustrate received packets and 49 lost packets.
 20

The Block Error Rates, BLERs, for the different transmissions are:

$$\text{BLER}_1 = 0.2$$

25 $\text{BLER}_2 = 0.06$

$\text{BLER}_{>2} = 0$ (it is assumed that incremental redundancy is used in all transmissions, reducing the BLER for each incremented transmission).

On the UL, the RLC non-persistent mode will discard all packages needing more than one
 30 retransmission: $1000 * 0.2 * 0.06 = 12$ blocks. This loss is not dependent on the use of the invention.

Thus, on the DL the transmitter receives $1000 - 12 = 988$ blocks.

35 *Without dynamic RLC non-persistent*

All 988 blocks are assumed to have a delay budget allowing for 1 retransmission. This implies that the number of RLC blocks lost on the DL is: $988*0.2*0.06 \approx 12$ blocks.

Thus, in total there is a Frame Erasure Rate, FER, of $(12+12)/1000 = 2.4 \%$.

5

With dynamic RLC non-persistent

In the following calculations it is assumed that the DL transmitter has the ability to analyze the packet arrival from the UL making correct assumptions for the DL delay budget.

- 10 Further it is assumed that the DL receiver (the user equipment) has the ability to analyze the packets from the DL transmitter (such as the BSC/PCU). According to one embodiment of the invention this is done by signalling in the transmitted data packets e.g. by using a bit of the header of the data packet showing maximum allowed re-transmissions. Thus, a zero (0) could represent one re-transmission and a one (1) could represent two
- 15 re-transmissions. According to another embodiment, a time-out value in the user equipment is determined, either by signalling a time-out value from the BSC/PCU or by analysing the received data packets in the user equipment. Such analysis is done in a similar way as the analysis in the BSC/PCU, i.e. by estimating the Packet Inter-arrival Time (PIT) by monitoring arrival of individual packets and/or by measuring number of packets arrived
- 20 during a time period.

$1000*0.8 = 800$ blocks are allowed to have 2 retransmissions on the DL since there was no retransmission for these blocks on the UL. All 800 are received correctly since the BLER of the third transmission is 0.

25

$(1000-800)*(1-0.06) = 188$ blocks need one retransmission before they are delivered to the DL. Since the delay budget allows for one retransmission on the DL, the number of discarded blocks, on DL, is $188*0.2*0.06 \approx 2$ blocks.

- 30 Thus, assuming ideal dynamic RLC non-persistent mode on the DL will decrease the FER on that link with more than 80 % compared to legacy RLC non-persistent mode.

In total there is a FER of $(12+2)/1000 = 1.4 \%$.

The procedure in a communication network entity, such as the BSC/PCU, for optimizing the performance of data packet transmissions between two user equipments via the communication network entity over an uplink transmission link and a downlink transmission link, whereby a pre-defined transmission delay is allowed for said data packets to travel from one of said user equipments to the other of said user equipments, shown in fig. 5 is as follows:

- analysing for the downlink transmission link received data packets originated from the uplink transmission link (step 51) e.g. by at least one of the following steps: estimating a Packet Inter-arrival Time (PIT) by monitoring arrival of individual packets; and/or, estimating a Packet Inter-arrival Time (PIT) by measuring a number of packets arrived during a pre-determined period of time;
- estimating a transmission delay on said uplink transmission link based on said analysed data packets (step 52).
- determining remaining transmission delay for said downlink transmission link (step 53);
- selecting for said analysed data packets an action based on said determined remaining transmission delay (step 54) which efficiently uses available radio resources on said downlink transmission link. The action is at least one of the following: determining maximum allowed re-transmissions on said downlink transmission link for individual data packets (which optionally is signalled to the receiving user equipment), selecting a modulation and coding scheme (MCS) based on a number of allowed re-transmissions in order to obtain an optimal robustness or, determining a time-out value for individual data packets (which optionally is signalled to the receiving user equipment);
- transmitting said data packets on said downlink transmission link to a receiving user equipment (step 55).

The procedure in a user equipment for optimizing the performance of data packet transmissions between two user equipments via a communication network entity, such as the BSC/PCU, over an uplink transmission link and a downlink transmission link, whereby a pre-defined transmission delay is allowed for said data packets to travel from one of said user equipments to the other of said user equipments, shown in fig. 6 is as follows:

- receiving data packets on said downlink transmission link from said communication network entity (step 61), in which communication network entity said data packets originating from said uplink transmission link have been analysed, a

transmission delay on said uplink transmission link based on said analysed data packets has been estimated, a remaining transmission delay for said downlink transmission link has been determined and an action for said analysed data packets has been selected based on said determined remaining transmission delay which efficiently uses available radio resources on said downlink transmission link;

5

- analysing the received data packets in the user equipment (step 62), e.g. by at least one of the following steps: estimating a Packet Inter-arrival Time (PIT) by monitoring arrival of individual packets; estimating a Packet Inter-arrival Time (PIT) by measuring a number of packets arrived during a pre-determined period of time.

10

The analysis is done to obtain a determined maximum allowed re-transmissions on said downlink transmission link and/or a determined time-out value for individual data packets. Optionally, the maximum allowed re-transmissions and/or the time-out value is signalled from the communication network entity, e.g. obtained by information in a header of the received data packets.

15

Figure 7 is a block diagram showing user equipments 12a and 12b and a communication network entity 16, such as the BSC/PCU for optimizing the performance of data packet transmissions between the two user equipments 12a and 12b via the communication network entity 16 over an uplink transmission link 11 and a downlink transmission link 13,

20

whereby a pre-defined transmission delay is allowed for said data packets to travel from one of said user equipments 12a to the other of said user equipments 12b. The communication network entity 16 comprises a radio transmitter 72 and a receiver 71. The transmitter 72 is transmitting data to a receiver 77 of the user equipment 12a and 12b over the radio interface on the downlink channel 13. The receiver 71 is receiving data from the

25

transmitter 76 of user equipment 12a and 12b on the uplink channel 11. The communication network entity further comprises means 73 for analysing for said downlink transmission link 13 received data packets originating from said uplink transmission link 11, for estimating a transmission delay on said uplink transmission link 11 based on said analysed data packets, for determining remaining transmission delay for said downlink transmission

30

link 13 and for selecting for said analysed data packets an action based on said determined remaining transmission delay which efficiently uses available radio resources on said downlink transmission link 13. This is described in more detail above and in conjunction with fig. 5.

The user equipment 12a and 12b comprises a radio transmitter 76 arranged to transmit data packets to the receiver 71 of the communication network entity 16 over the radio interface on the uplink channel 11 and a receiver 77 arranged to receive data packets transmitted from the transmitter 72 of the communication network entity 16 on the
5 downlink channel 13. The user equipment 12a and 12b further comprises means 78 for analysing said received data packets as described above and in conjunction with fig. 6.

Thus, while there have been shown and described and pointed out fundamental novel features of the invention as applied to a preferred embodiment thereof, it will be understood that various omissions and substitutions and changes in the form and details of the devices illustrated, and in their operation, may be made by those skilled in the art without departing from the spirit of the invention. For example, it is expressly intended that all combinations of those elements and/or method steps which perform substantially the same function in substantially the same way to achieve the same results are within the
10 scope of the invention. Moreover, it should be recognized that structures and/or elements and/or method steps shown and/or described in connection with any disclosed form or embodiment of the invention may be incorporated in any other disclosed or described or suggested form or embodiment as a general matter of design choice. It is the intention, therefore, to be limited only as indicated by the scope of the claims appended hereto.

20

Expressions such as "including", "comprising", "incorporating", "consisting of", "have", "is" used to describe and claim the present invention are intended to be construed in a non-exclusive manner, namely allowing for items, components or elements not explicitly described also to be present. Reference to the singular is also to be construed to relate to
25 the plural and vice versa.

Numerals included within parentheses in the accompanying claims are intended to assist understanding of the claims and should not be construed in any way to limit subject matter claimed by these claims.

30

CLAIMS

1. Method in a communication network entity of optimizing the performance of data packet transmissions between two user equipments via said communication network entity over an uplink transmission link and a downlink transmission link, where-
5 by a pre-defined transmission delay is allowed for said data packets to travel from one of said user equipments to the other of said user equipments, **characterised in that** the method comprises the steps of:
- analysing for said downlink transmission link received data packets originating from said uplink transmission link;
 - 10 - estimating a transmission delay on said uplink transmission link based on said analysed data packets;
 - determining remaining transmission delay for said downlink transmission link;
 - selecting for said analysed data packets an action based on said determined remaining transmission delay which efficiently uses available radio resources on said
15 downlink transmission link, where after said data packets are transmitted on said downlink transmission link to a receiving user equipment.
2. Method according to claim 1, **characterised in that** said action is to determine maximum allowed re-transmissions on said downlink transmission link for individual
20 data packets based on said determined remaining transmission delay.
3. Method according to claim 2, **characterised in that** the method further comprises the step of signalling to said receiving user equipment said determined maximum allowed re-transmissions on said downlink.
25
4. Method according to claim 1, **characterised in that** said action is to select a modulation and coding scheme (MCS) based on a number of allowed re-transmissions based on said determined remaining transmission delay in order to obtain an optimal robustness.
30
5. Method according to claim 1, **characterised in that** said action is to determine a time-out value for individual data packets based on said determined remaining transmission delay.

6. Method according to claim 5, **characterised in that** the method further comprises the step of signalling to said receiving user equipment said determined time-out value for individual data packets.
- 5 7. Method according to claim 1, **characterised in that** said step of analysing comprises the step of estimating a Packet Inter-arrival Time (PIT) by monitoring arrival of individual packets.
8. Method according to claim 1 or 7, **characterised in that** said step of analysing
10 comprises the step of estimating a Packet Inter-arrival Time (PIT) by measuring a number of packets arrived during a pre-determined period of time.
9. Method in a user equipment of optimizing the performance of data packet transmis-
15 sions between two user equipments via a communication network entity over an up-
link transmission link and a downlink transmission link, whereby a pre-defined
transmission delay is allowed for said data packets to travel from one user equip-
ment to said user equipment, **characterised in that** the method comprises the
steps of:
- receiving data packets on said downlink transmission link from said communication
20 network entity, in which communication network entity said data packets originating
from said uplink transmission link have been analysed, a transmission delay on said
uplink transmission link based on said analysed data packets has been estimated, a
remaining transmission delay for said downlink transmission link has been deter-
mined and an action for said analysed data packets has been selected based on
25 said determined remaining transmission delay which efficiently uses available radio
resources on said downlink transmission link;
- analysing said received data packets.
10. Method according to claim 9, **characterised in that** said analysis of said received
30 data packets is done in order to obtain a determined maximum allowed re-transmis-
sions on said downlink transmission link.
11. Method according to claim 10, **characterised in that** said maximum allowed re-
transmissions on said downlink transmission link is obtained by information in a

header of said received data packets.

12. Method according to claim 9, **characterised in that** said analysis of said received data packets is done in order to obtain a determined time-out value for individual data packets.
13. Method according to claim 12, **characterised in that** said time-out value is obtained by information in a header of said received data packets.
14. Method according to claim 9, **characterised in that** said step of analysing comprises the step of estimating a Packet Inter-arrival Time (PIT) by monitoring arrival of individual packets.
15. Method according to claim 9 or 14, **characterised in that** said step of analysing comprises the step of estimating a Packet Inter-arrival Time (PIT) by measuring a number of packets arrived during a pre-determined period of time.
16. A communication network entity for optimizing the performance of data packet transmissions between two user equipments (12a, 12b) via said communication network entity (16) over an uplink transmission link (11) and a downlink transmission link (13), whereby a pre-defined transmission delay is allowed for said data packets to travel from one of said user equipments to the other of said user equipments, **characterised in that** said entity comprises:
- means (73) for analysing for said downlink transmission link (13) received data packets originating from said uplink transmission link (11);
 - means (73) for estimating a transmission delay on said uplink transmission link (11) based on said analysed data packets;
 - means (73) for determining remaining transmission delay for said downlink transmission link (13);
 - means (73) for selecting for said analysed data packets an action based on said determined remaining transmission delay which efficiently uses available radio resources on said downlink transmission link (13), where after said data packets are transmitted on said downlink transmission link (13) to a receiving user equipment.

17. A communication network entity according to claim 16, **characterised in that** said means (73) for selecting an action is arranged to determine maximum allowed re-transmissions on said downlink transmission link (13) for individual data packets based on said determined remaining transmission delay.
- 5
18. A communication network entity according to claim 17, **characterised in that** said communication network entity (16) further comprises means for signalling to said receiving user equipment said determined maximum allowed re-transmissions on said downlink transmission link (13).
- 10
19. A communication network entity according to claim 16, **characterised in that** said means (73) for selecting an action is arranged to select a modulation and coding scheme (MCS) based on a number of allowed re-transmissions based on said determined remaining transmission delay in order to obtain an optimal robustness.
- 15
20. A communication network entity according to claim 16, **characterised in that** said means (73) for selecting an action is arranged to determine a time-out value for individual data packets based on said determined remaining transmission delay.
- 20
21. A communication network entity according to claim 20, **characterised in that** said communication network entity (16) further comprises means for signalling to said receiving user equipment said determined time-out value for individual data packets.
- 25
22. A communication network entity according to claim 16, **characterised in that** said means (73) for analysing is arranged to estimate a Packet Inter-arrival Time (PIT) by monitoring arrival of individual packets.
- 30
23. A communication network entity according to claim 16 or 22, **characterised in that** said means (73) for analysing is arranged to estimate a Packet Inter-arrival Time (PIT) by measuring a number of packets arrived during a pre-determined period of time.
- 35
24. A user equipment for optimizing the performance of data packet transmissions between two user equipments (12a, 12b) via a communication network entity (16) over an uplink transmission link (11) and a downlink transmission link (13), whereby a

pre-defined transmission delay is allowed for said data packets to travel from one user equipment to said user equipment, **characterised in that** the user equipment comprises:

- 5 - means (37) for receiving data packets on said downlink transmission link (13) from said communication network entity (16), in which communication network entity (16) said data packets originating from said uplink transmission link (11) have been analysed, a transmission delay on said uplink transmission link (11) based on said analysed data packets has been estimated, a remaining transmission delay for said downlink transmission link (13) has been determined and an action for said ana-
10 lysed data packets has been selected based on said determined remaining transmission delay which efficiently uses available radio resources on said downlink transmission link (13);
 - means (78) for analysing said received data packets.
- 15 25. A user equipment according to claim 22, **characterised in that** said means (78) for analysing is arranged to obtain a determined maximum allowed re-transmissions on said downlink transmission link (13).
- 20 26. A user equipment according to claim 23, **characterised in that** said means (78) for analysing is arranged to obtain said maximum allowed re-transmissions on said downlink transmission link (13) by information in a header of said received data packets.
- 25 27. A user equipment according to claim 22, **characterised in that** said means (78) for analysing is arranged to obtain a determined time-out value for individual data packets.
- 30 28. A user equipment according to claim 25, **characterised in that** said means (78) for analysing is arranged to obtain said time-out value by information in a header of said received data packets.
- 35 29. A user equipment according to claim 24, **characterised in that** said means (78) for analysing is arranged to estimate a Packet Inter-arrival Time (PIT) by monitoring arrival of individual packets.

30. A user equipment according to claim 24 or 29, **characterised in that** said means (78) for analysing is arranged to estimate a Packet Inter-arrival Time (PIT) by measuring a number of packets arrived during a pre-determined period of time.

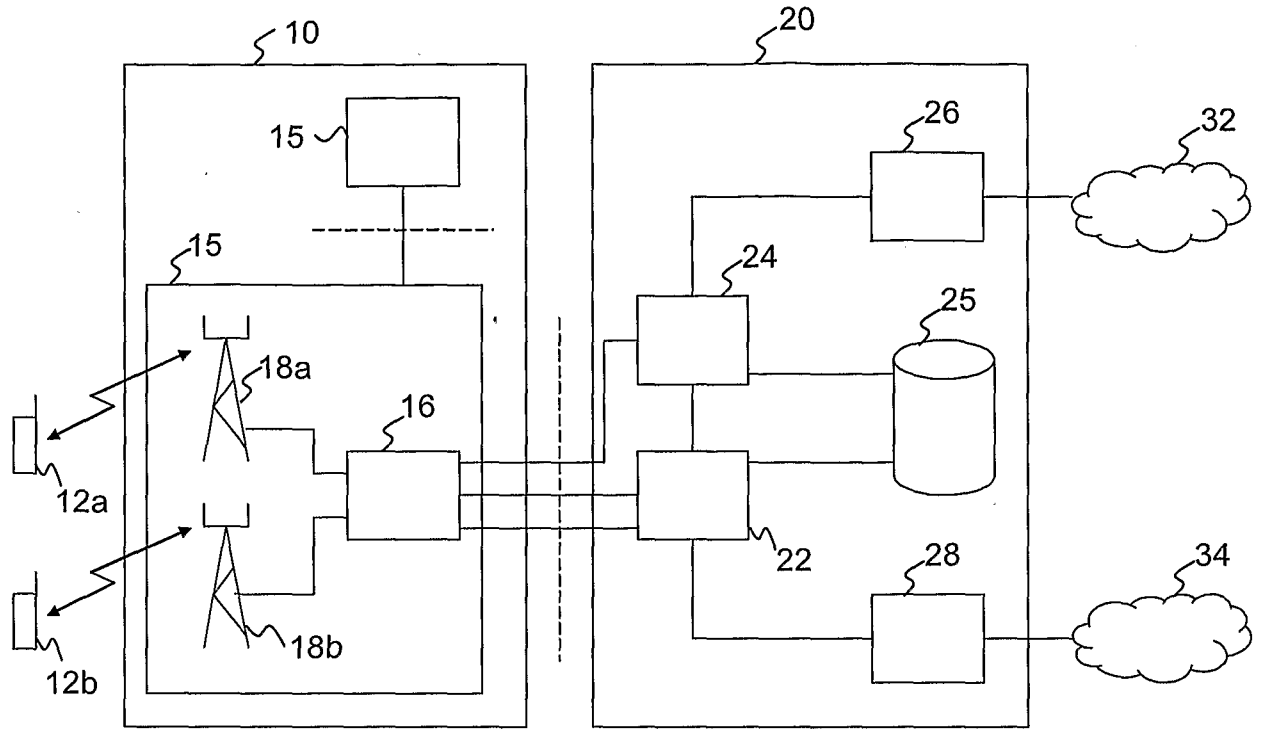

Fig. 1

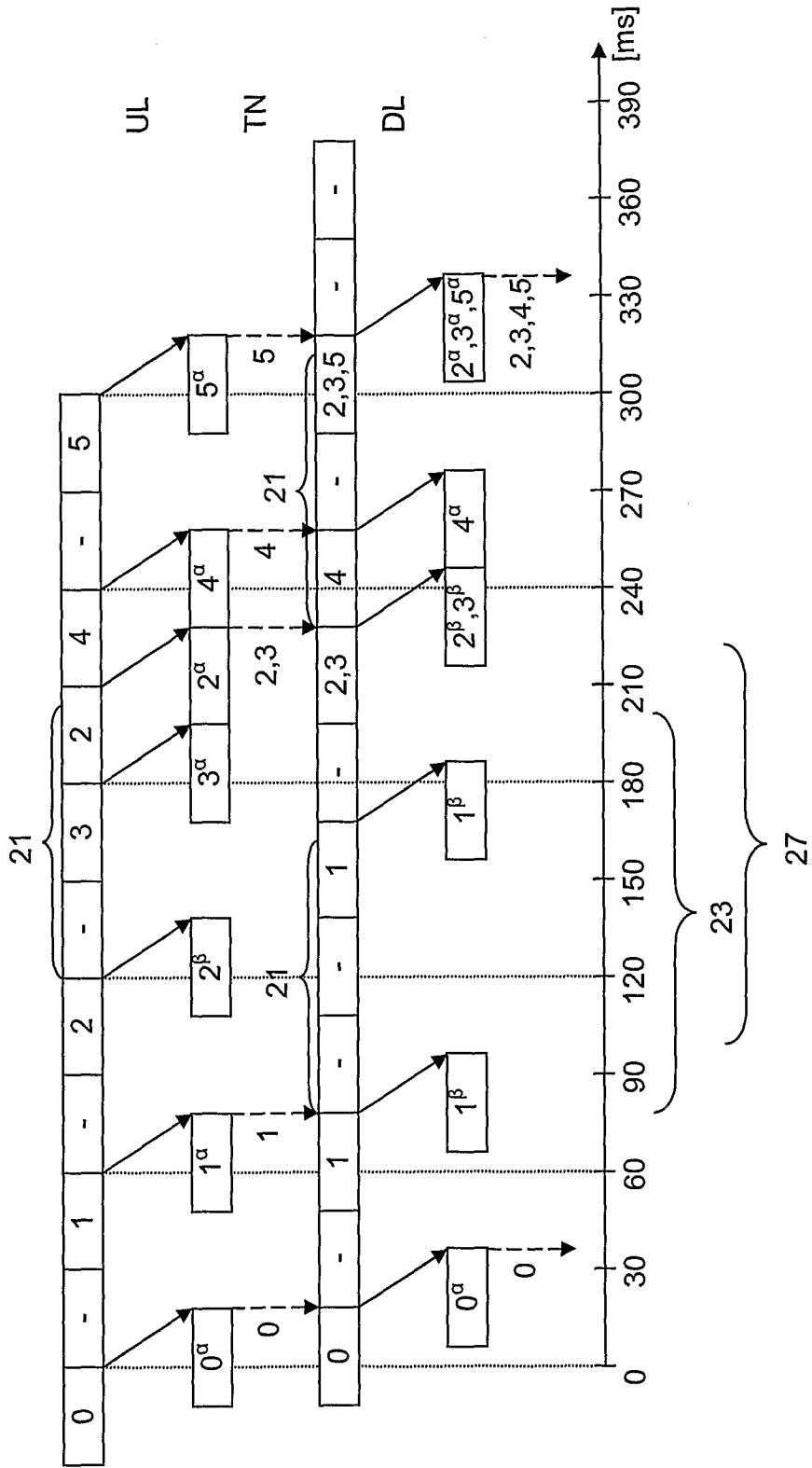

Fig. 2

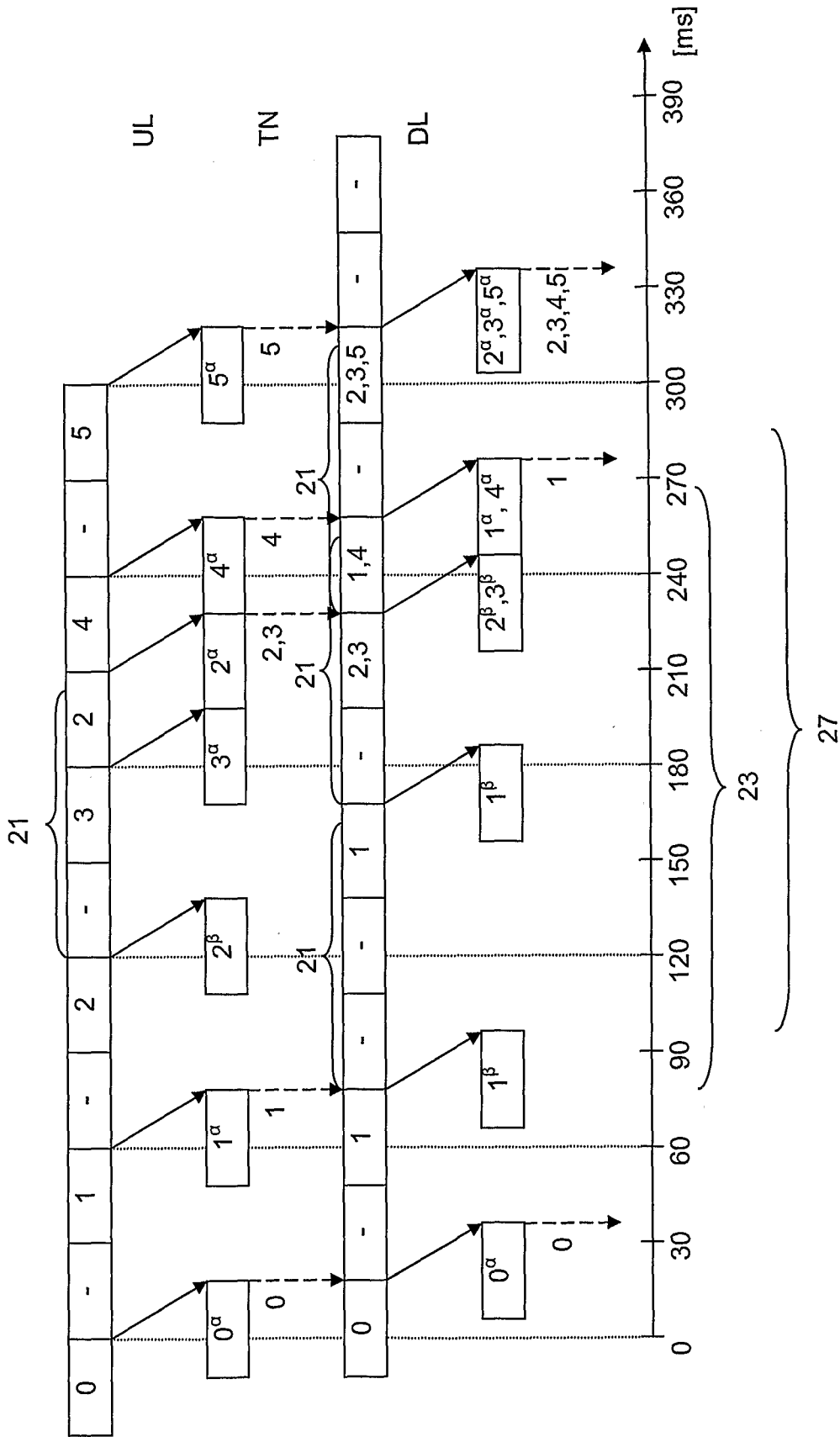

Fig. 3

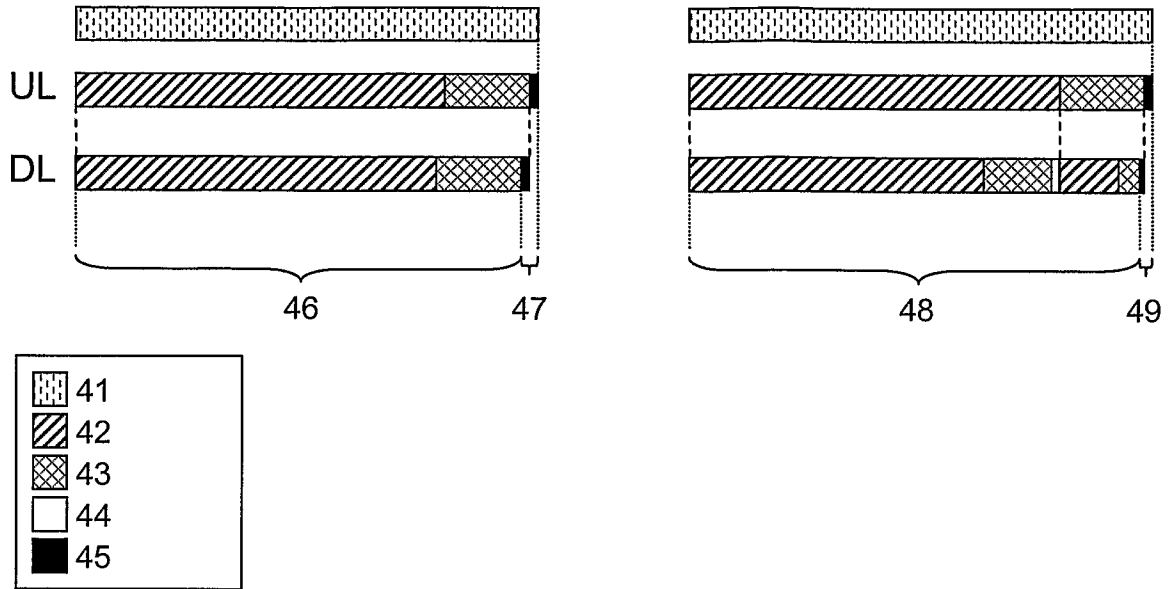

Fig. 4

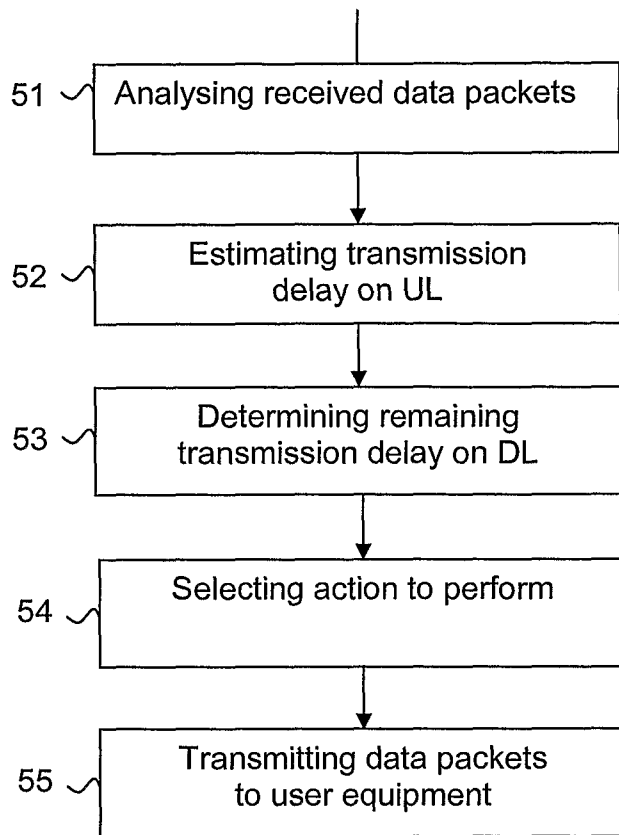

Fig. 5

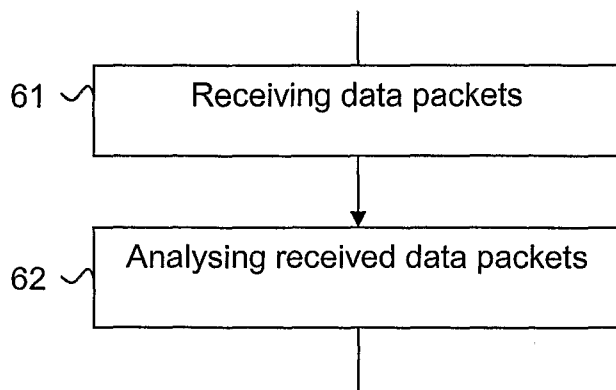

Fig. 6

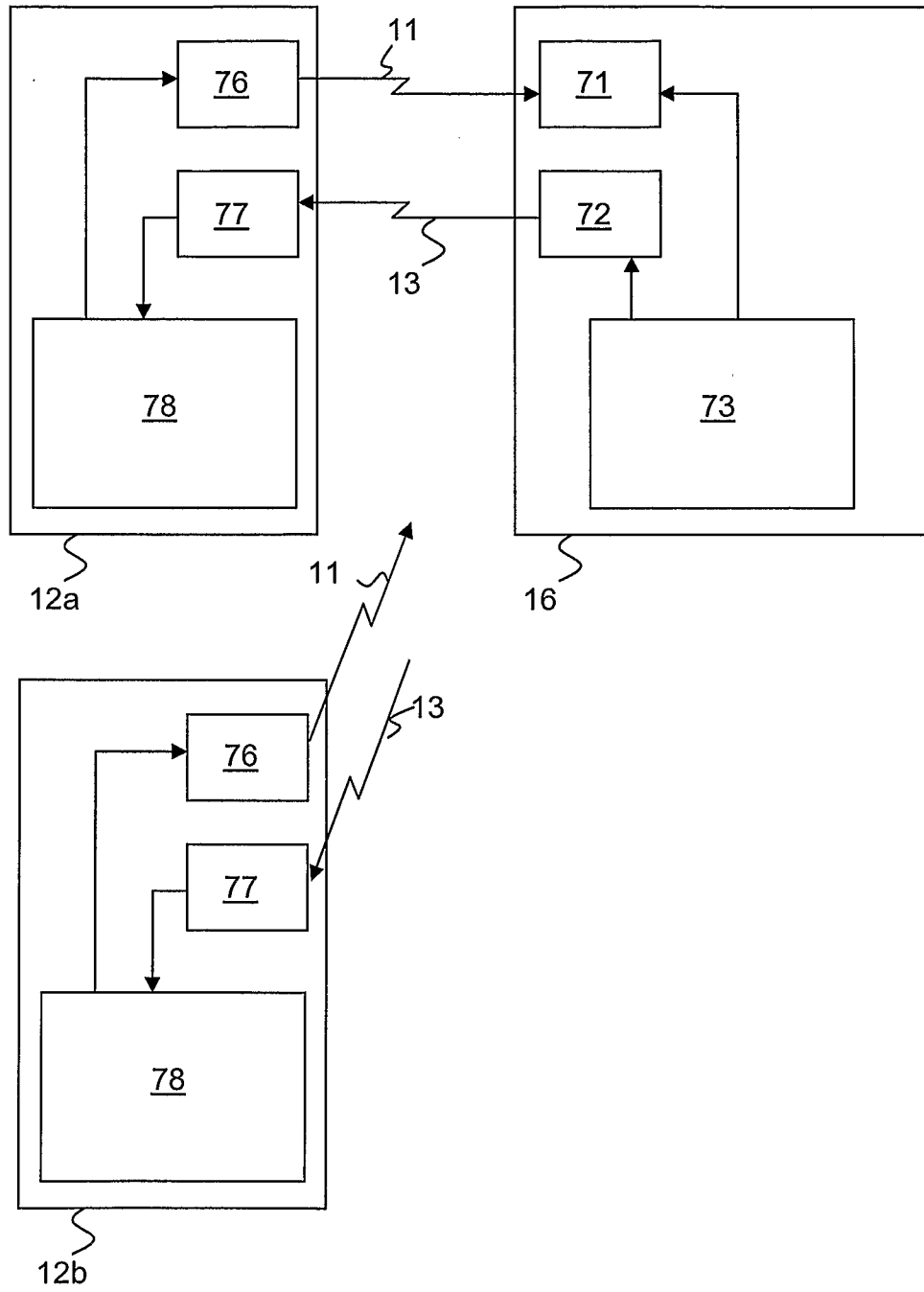

Fig. 7

INTERNATIONAL SEARCH REPORT

International application No.

PCT/SE2007/050778

A. CLASSIFICATION OF SUBJECT MATTER

IPC: see extra sheet

According to International Patent Classification (IPC) or to both national classification and IPC

B. FIELDS SEARCHED

Minimum documentation searched (classification system followed by classification symbols)

IPC: H04B, H04L, H04Q

Documentation searched other than minimum documentation to the extent that such documents are included in the fields searched

SE,DK,FI,NO classes as above

Electronic data base consulted during the international search (name of data base and, where practicable, search terms used)

EPO-INTERNAL, WPI DATA, PAJ

C. DOCUMENTS CONSIDERED TO BE RELEVANT

Category*	Citation of document, with indication, where appropriate, of the relevant passages	Relevant to claim No.
A	US 20070110002 A1 (YANG ET AL), 17 May 2007 (17.05.2007), figure 1, abstract, paragraph (0032) --	1-30
A	EP 1643784 A1 (MATSUSHITA ELECTRIC INDUSTRIAL CO., LTD.), 5 April 2006 (05.04.2006), abstract, paragraphs (0067)-(0068) --	1-30
A	WO 9848535 A1 (TELEFONAKTIEBOLAGET LM ERICSSON), 29 October 1998 (29.10.1998), abstract --	1-30
A	US 20040196801 A1 (HIRAMATSU), 7 October 2004 (07.10.2004), abstract -- -----	1-30

 Further documents are listed in the continuation of Box C. See patent family annex.

* Special categories of cited documents:

"A" document defining the general state of the art which is not considered to be of particular relevance

"E" earlier application or patent but published on or after the international filing date

"L" document which may throw doubts on priority claim(s) or which is cited to establish the publication date of another citation or other special reason (as specified)

"O" document referring to an oral disclosure, use, exhibition or other means

"P" document published prior to the international filing date but later than the priority date claimed

"T" later document published after the international filing date or priority date and not in conflict with the application but cited to understand the principle or theory underlying the invention

"X" document of particular relevance: the claimed invention cannot be considered novel or cannot be considered to involve an inventive step when the document is taken alone

"Y" document of particular relevance: the claimed invention cannot be considered to involve an inventive step when the document is combined with one or more other such documents, such combination being obvious to a person skilled in the art

"&" document member of the same patent family

Date of the actual completion of the international search

4 Sept 2008

Date of mailing of the international search report

16-09-2008

Name and mailing address of the ISA/
Swedish Patent Office
Box 5055, S-102 42 STOCKHOLM
Facsimile No. +46 8 666 02 86

Authorized officer

Ralf Boström / JA A
Telephone No. +46 8 782 25 00

INTERNATIONAL SEARCH REPORT

International application No.
PCT/SE2007/050778

International patent classification (IPC)

H04L 1/18 (2006.01)

H04L 1/00 (2006.01)

Download your patent documents at www.prv.se

The cited patent documents can be downloaded at www.prv.se by following the links:

- In English/Searches and advisory services/Cited documents (service in English) or
- e-tjänster/anförda dokument (service in Swedish).

Use the application number as username.

The password is **TVLNTYRBIT**.

Paper copies can be ordered at a cost of 50 SEK per copy from PRV InterPat (telephone number 08-782 28 85).

Cited literature, if any, will be enclosed in paper form.

INTERNATIONAL SEARCH REPORT

28/06/2008

International application No.

PCT/SE2007/050778

US	20070110002	A1	17/05/2007	CN	1976268 A	06/06/2007
EP	1643784	A1	05/04/2006	CN	101053270 A	10/10/2007
				WO	2006034747 A	06/04/2006
WO	9848535	A1	29/10/1998	AU	7091298 A	13/11/1998
				BR	9808575 A	30/05/2000
				CA	2287432 A,C	29/10/1998
				CN	1135760 B	21/01/2004
				CN	1135761 C	21/01/2004
				CN	1261486 A,T	26/07/2000
				EP	0976214 A	02/02/2000
				JP	4017083 B	05/12/2007
				JP	2001521710 T	06/11/2001
				TW	465201 B	21/11/2001
				US	5936964 A	10/08/1999
US	20040196801	A1	07/10/2004	AU	2003220936 A	00/00/0000
				CN	1537371 A	13/10/2004
				EP	1489769 A	22/12/2004
				JP	3561510 B	02/09/2004
				JP	2003283471 A	03/10/2003
				WO	03081834 A	02/10/2003