

Aug. 29, 1961

W. T. TILLOTSON

2,998,337

REFLECTIVE-FIBROUS TYPE INSULATION

Filed June 7, 1957

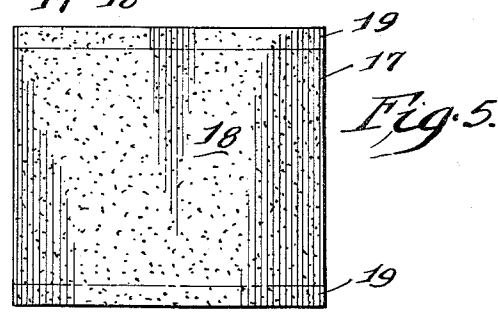
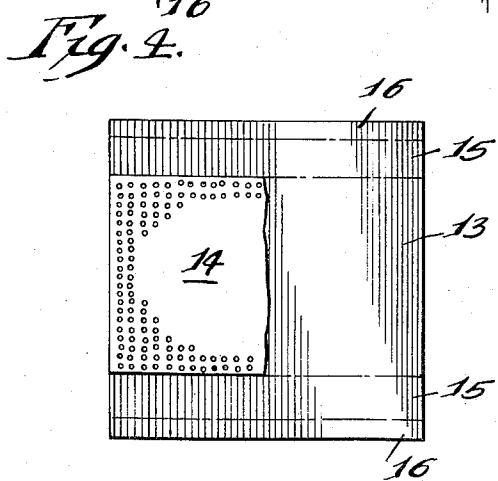
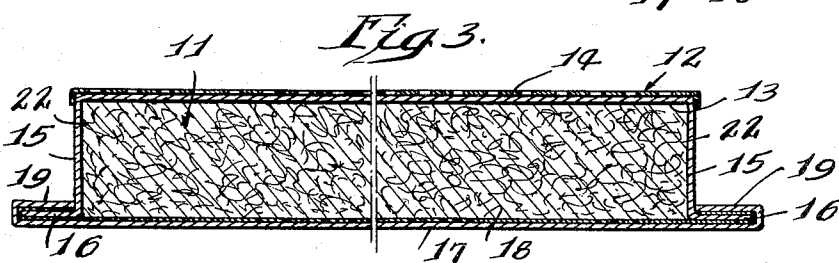
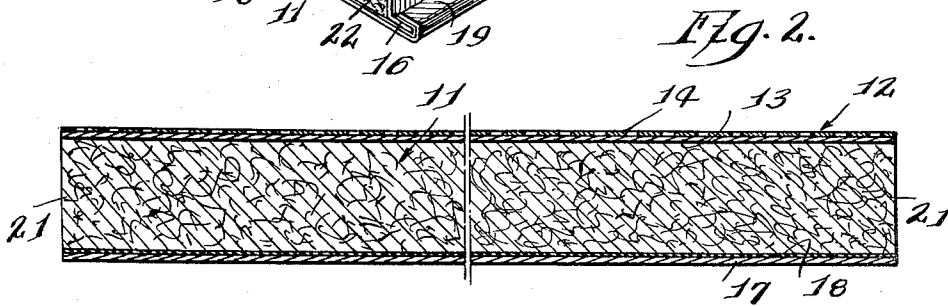
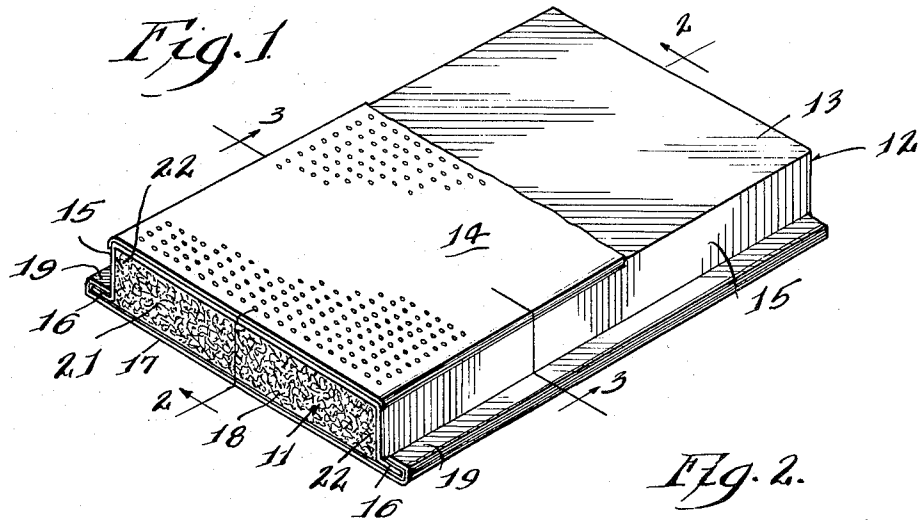

Inventor:  
Wesley T. Tillotson  
By Milmont Leffer  
Attorneys

1

2,998,337

**REFLECTIVE-FIBROUS TYPE INSULATION**

Wesley T. Tillotson, Wilmette, Ill., assignor, by mesne assignments, to United States Gypsum Company, Chicago, Ill., a corporation of Illinois

Filed June 7, 1957, Ser. No. 664,196

4 Claims. (Cl. 154-44)

The present invention relates to a novel reflective-fibrous type insulation in which a fibrous insulating material such as batt of mineral wool, is provided on its opposite sides or exposed surfaces with a sheet of reflective material, such as aluminum or other metal foil.

When reflective surface material or metal foil is applied as a covering for the sides and edges of a batt or fibrous insulation, such covering provides a continuous metallic link from the warm side to the cold side of the insulation whereby heat transfer through the metallic covering substantially diminishes the insulating properties of the assembled unit. Furthermore, extending the metallic surface material over and along the edges of the assembled unit performs no useful function, interferes with the successful compression packaging of these insulation units and may prevent their return to their original thickness.

By means of the present invention a continuous metallic link from the warm side to the cold side is eliminated and the novel assembly increases the insulating properties of the composite unit. In addition, it reduces the cost of the composite assembly in that it reduces the quantity of metallic reflective surface material required, promotes successful compression packaging of these units to decrease their bulk and aids return of the compressed composite units to their original thickness.

It is, therefore, an important object of the present invention to provide a novel composite insulation unit having a sheet or strip of metal foil providing a reflective surface material on its exposed surfaces only with the metal foil providing one exposed surface being imperforate to form a vapor barrier that prevents the passage of moisture and the other sheet or strip of metal foil providing the other exposed surface being perforated to provide a permeable membrane that permits the escape of any entrapped moisture that may have collected or obtained access to the interior of the insulating unit.

Another important object of the present invention is the provision of a novel insulating unit comprising a batt of insulating material, such as mineral wool, and a novel covering or envelope encompassing the batt, such covering or envelope comprising a sheet of retaining paper overlying one surface or side of and overlapping the opposite edges of the batt and to the exterior of this paper is superimposed and affixed a sheet of perforated metal foil providing an exposed surface, and a sheet of imperforate metal foil overlying the opposite surface or side of the batt and joined to the opposite edges of the retaining paper, the latter providing the other exposed surface of the insulating unit.

A further object of the present invention is the provision of a novel means and manner of forming an insulating unit including a batt of fibrous insulating material and an encompassing covering for the batt, said covering having a strip of metal foil or reflective surface material providing the opposite exposed surfaces

2

of the unit, with the opposite edges of the unit being devoid of any metallic link between the strips of metal foil.

Further objects are to provide a construction of maximum simplicity, efficiency, economy and ease of assembly and operation, and such further objects, advantages and capabilities as will later more fully appear and are inherently possessed thereby.

In the drawing:

FIGURE 1 is a view in perspective of the novel composite insulating unit of the present invention, but with a portion of the overlying or external sheet of metal foil on one face having been broken away.

FIG. 2 is an enlarged fragmentary view in vertical cross section taken longitudinally through the insulating unit in a plane represented by the line 2-2 of FIG. 1 and viewed in the direction of the arrows.

FIG. 3 is an enlarged fragmentary vertical cross-sectional view through the insulating unit but taken in a plane represented by the line 3-3 of FIG. 1 and viewed in the direction of the arrows.

FIG. 4 is a top plan view but on a reduced scale from that in FIGS. 1, 2 and 3 of the sheet of retaining paper and its overlying strip of perforated metal foil extending longitudinally and substantially centrally of and affixed to the paper, a portion of the strip of metal foil having been removed to show the underlying sheet of paper.

FIG. 5 is a top plan view but also on a reduced scale of the imperforate sheet of metal foil to which has been applied a coating of asphalt.

Referring to the disclosure in the drawing and to the illustrative embodiment disclosed therein, the novel insulation unit consists of a suitable thickness of fibrous insulation material, such as a batt of mineral wool 11, having a covering or envelope 12 encompassing the batt and comprising a sheet of retaining paper 13 to which is affixed a centrally arranged and longitudinally extending strip of perforated metal foil or reflective material 14, such as aluminum foil, superimposed on the upper or outer surface of the paper.

The strip of metal foil 14 which is centrally disposed upon the sheet of retaining paper 13 and adhesively joined thereto is of a width to completely overlie one face or side of the batt of insulation and extend over the longitudinal corners as shown in FIG. 3, with the spaced exposed portions 15 of this paper sheet overlapping and covering the opposite edges of the batt 11, the longitudinal edges of the paper providing an external flange 16 at each side thereof.

By retaining the outer edges of the strip of metal foil 14 imperforate and unbroken, these imperforate edges provide for greater strength, surface adhesion and retention of the metal foil 14 upon the underlying sheet of retaining paper 13, and resist fraying or tearing along these edges during manufacture and use.

The other side of the batt (shown as the lower or inner surface in the drawings) is covered by a sheet of imperforate metal foil or reflective material 17 having a coating of asphalt 18 applied to one face thereof over its entire length and width, the width being substantially greater than the width of the batt of insulation 11 with the edges 19 thereof adapted to overlap the external flanges 16 of the retaining paper 13. When the edges

19 are bent over the flanges 16 to form the overlap, pressure applied to the overlap adhesively joins these edges and flanges and provides an effective seal.

These composite insulation units with the envelope or covering 12 extending for the full length of the batt are of substantial dimensions for providing insulation in the ceiling, side walls and/or flooring of an enclosure or building. When assembled, the side of the units with the sheet or strip of imperforate metal foil 17 exposed faces the interior of the enclosure so as to provide a vapor barrier against the passage of moisture to the walls, ceiling or floor. The other or outer exposed face of these insulating units is covered by the sheet or strip of perforated metal foil 14 to permit the escape of moisture or condensate that might collect.

As one example and for ease in packaging and use, these insulating units may be approximately 15 inches wide, approximately 3 inches thick and may be in units having a length approximately 24 inches, 48 inches or greater, although these measurements are intended merely as illustrative and not as a limitation of the present invention. The opposite ends 21 of the insulating batt 11 are not enclosed by the covering or envelope.

As the sheets or strips of metal foil 14 and 17 do not encompass or cover the opposite edges 22 of the novel insulating units which are covered only by the sheet of retaining paper, there is no metallic link or conduction from the warm side to the cold side of the unit so that a minimum heat transfer is effected. Furthermore, as these opposite edges 22 are not covered or enclosed by the metal foil, the units so constructed and assembled may be successfully compression packaged and, when removed from the package for use, automatically return to their original dimensions or thickness. It will be further appreciated that by retaining these edges uncovered by the metal foil, there is a substantial saving in such metal foil.

The novel insulating unit of the present invention is effective during winter when the heat flow is up and out of a building or enclosure, and when the heat flow is down as occurs during the hot summer weather. The metal foil or reflective surface material is particularly effective when the heat flow is down and supplements the protection afforded by the fibrous insulation for use with air conditioning or artificial cooling. As there is no metallic link or heat conduction from the warm to the cold side, the insulation value of the present assembly is increased.

Having thus disclosed the invention, I claim:

1. A resiliently compressible insulating unit for providing insulation to a building structure surface consisting of a compressible batt of insulating material; and an envelope for enclosing the normally-outer-facing and normally-inner-facing surfaces and two laterally opposed sides of said compressible batt, said envelope consisting of a paper sheet substantially completely covering said normally-outer-facing and two laterally opposed sides of said batt and extending from said sides adjacent the normally-inner-facing surface of said batt to form a pair of flanges, an imperforate metal foil sheet affixed to and substantially completely covering the normally-inner-facing surface of said batt, the lateral edge portions of said imperforate metal foil sheet being affixed to said flanges of said paper sheet, a strip of perforate metal foil affixed to and substantially conterminous with the portion of said paper sheet covering said normally-outer-facing surface, said perforate metal foil providing a heat-reflective surface and permeable membrane for the escape of moisture vapor entrapped in said batt, and the portions of said paper sheet covering the laterally opposed sides of said batt being substantially free and uncovered by said metal foil sheets, whereby there is no contact between said perforate and imperforate foil sheets.

2. A resiliently compressible insulating unit for providing insulation to a building structure surface consist-

ing of a compressible batt of fibrous insulation; and an envelope for enclosing the normally-outer-facing and normally-inner-facing surfaces and two laterally opposed sides of said compressible batt, said envelope consisting of a paper sheet substantially completely covering said normally-outer-facing surface and two laterally opposed sides of said batt and extending from said sides adjacent the normally-inner-facing surface of said batt to form a pair of flanges, an imperforate metal foil sheet adhesively affixed to and substantially completely covering the normally-inner-facing surface of said batt, the lateral edge portions of said imperforate metal foil sheet being affixed to said flanges of said paper sheet, a strip of perforate metal foil affixed to and substantially conterminous with the portion of said paper sheet covering said normally-outer-facing surface, said perforate metal providing a heat-reflective surface and permeable membrane for the escape of moisture vapor entrapped in said batt, and the portions of said paper sheet covering the laterally opposed sides of said batt being substantially free and uncovered by said metal foil sheets, whereby there is no contact between said perforate and imperforate foil sheets.

3. A resiliently compressible insulating unit for providing insulation to a building structure surface consisting of a compressible batt of fibrous insulation; and an envelope for enclosing the normally-outer-facing and normally-inner-facing surfaces and two laterally opposed sides of said compressible batt, said envelope consisting of a paper sheet substantially completely covering said normally-outer-facing surface and two laterally opposed sides of said batt and extending from said sides adjacent the normally-inner-facing surface of said batt to form a pair of flanges, an imperforate metal foil sheet adhesively affixed to and substantially completely covering the normally-inner-facing surface of said batt, the lateral edge portions of said imperforate metal foil sheet being adhesively affixed to said flanges of said paper sheet, a strip of perforate metal foil affixed to and substantially conterminous with the portion of said paper sheet covering said normally-outer-facing surface, said perforate metal foil being devoid of perforations in the lateral portions adjacent the juncture of said normally-outer-facing surface and the side surfaces to provide for greater strength and surface retention of said lateral portions of said perforate metal foil to the paper sheet and to resist fraying and tearing along said lateral portions of said perforate metal foil, said perforate metal foil providing a heat reflective surface and permeable membrane adapted to permit the escape of moisture vapor entrapped in said batt, and the portions of said paper sheet covering the laterally opposed sides of said batt being substantially free and uncovered by said metal foil sheets, whereby there is no contact between said perforate and imperforate foil sheets.

4. A resiliently compressible insulating unit for providing insulation to a building structure surface consisting of a compressible batt of fibrous insulation; and an envelope for enclosing the normally-outer-facing and normally-inner-facing surfaces and two laterally opposed sides of said compressible batt, said envelope consisting of a paper sheet substantially completely covering said normally-outer-facing surface and two laterally opposed sides of said batt and extending from said sides adjacent the normally-inner-facing surface of said batt to form a pair of flanges, a sheet of imperforate metal foil having a coating of asphalt on one surface thereof, which surface is adhesively affixed to and covers the normally-inner-facing surface of said batt and is in overlapping and sealed relationship to said flanges, a strip of perforate metal foil affixed to and substantially conterminous with the portion of said paper sheet covering said normally-outer-facing surface, said perforate metal foil being devoid of perforations in the lateral portions adjacent the juncture of said normally-outer-facing surface and the side surfaces

to provide for greater strength and surface retention of said lateral portions of said perforate metal foil to the paper sheet and to resist fraying and tearing along said lateral portions of said perforate metal foil, said perforate metal foil providing a heat reflective surface and permeable membrane adapted to permit the escape of moisture vapor entrapped in said batt, and the portions of said paper sheet covering the laterally opposed sides of said batt being substantially free and uncovered by said metal foil sheets, whereby there is no contact between said perforate and imperforate foil sheets.

1,914,345  
 5 2,101,836  
 2,192,653  
 2,312,987  
 2,576,698  
 2,674,335  
 10 2,757,116

## References Cited in the file of this patent

## UNITED STATES PATENTS

Roos -----	June 13, 1933
Benedict -----	Dec. 14, 1937
Schenk -----	Mar. 5, 1940
Grassick -----	Mar. 2, 1943
Russum -----	Nov. 27, 1951
Lemmerman -----	Apr. 6, 1954
Clements -----	July 31, 1956

UNITED STATES PATENT OFFICE  
CERTIFICATE OF CORRECTION

Patent No. 2,998,337

August 29, 1961

Wesley T. Tillotson

It is hereby certified that error appears in the above numbered patent requiring correction and that the said Letters Patent should read as corrected below.

Column 3, line 35, for "apprecated" read -- appreciated --; column 4, line 16, after "metal" insert -- foil --; line 18, for "entrappedd" read -- entrapped --; line 27, after "normally", second occurrence, insert a hyphen.

Signed and sealed this 13th day of February 1962.

(SEAL)

Attest:

ERNEST W. SWIDER

Attesting Officer

DAVID L. LADD

Commissioner of Patents